



TELEDYNE
OLDHAM SIMTRONICS
Everywhereyoulook™

OPERATING MANUAL

GD10-P00 and GD10-PE0

INFRARED POINT GAS DETECTOR

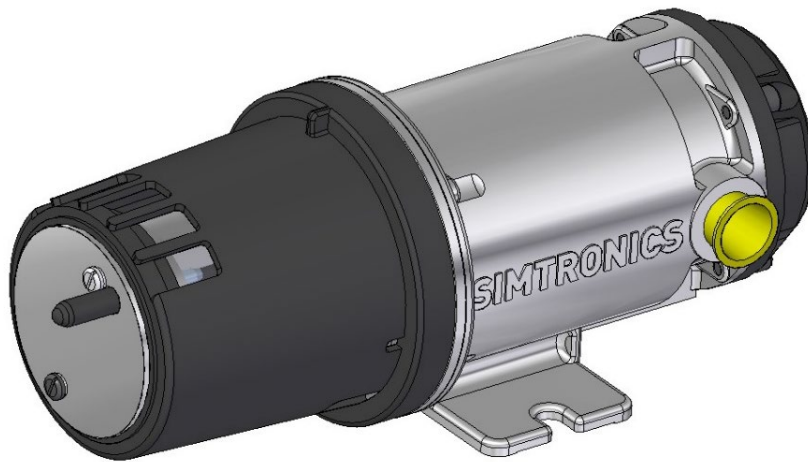

GD10-P00 and GD10-PE0

INFRARED POINT GAS DETECTOR
OPERATING MANUAL

User Manuals in other languages are available on
Website <https://teledynegasandflamedetection.com>



Copyright © June 2021 by TELEDYNE OLDHAM SIMTRONICS S.A.S.

All rights reserved. No reproduction of all or part of this document, in any form, is permitted without the written consent of TELEDYNE OLDHAM SIMTRONICS S.A.S.

All of the information that is provided in this document is accurate to the best of our knowledge.

As a result of continuous research and development, the specifications of this product may be changed without prior notice.

English version is the original version

TELEDYNE OLDHAM SIMTRONICS S.A.S.

Rue Orfila

Z.I. Est – CS 20417

62027 ARRAS Cedex

Thank you for choosing this TELEDYNE OLDHAM SIMTRONICS instrument.

All the necessary actions have been taken in order to ensure your complete satisfaction with this equipment.

It is important that you read this entire manual carefully and thoroughly.

Limitation of Liability

The Company TELEDYNE OLDHAM SIMTRONICS S.A.S., hereinafter referred to as "TELEDYNE OLDHAM SIMTRONICS" throughout this document, shall not be held responsible for any damage to the equipment or for any physical injury or death resulting in whole or in part from the inappropriate use or installation of the equipment, non-compliance with any and all instructions, warnings, standards and/or regulations in force.

No business, person or legal entity may assume responsibility on behalf of TELEDYNE OLDHAM SIMTRONICS, even though they may be involved in the sale of TELEDYNE OLDHAM SIMTRONICS products.

TELEDYNE OLDHAM SIMTRONICS shall not be responsible for any direct or indirect damage, or any direct or indirect consequence, resulting from the sale and use of any of its products **UNLESS SUCH PRODUCTS HAVE BEEN SELECTED BY TELEDYNE OLDHAM SIMTRONICS ACCORDING TO THE APPLICATION.**

Ownership clauses

The drawings, specifications, and information herein contain confidential information that is the property of TELEDYNE OLDHAM SIMTRONICS.

This information shall not, either in whole or in part, by physical, electronic, or any other means whatsoever, be reproduced, copied, divulged, translated, or used as the basis for the manufacture or sale of TELEDYNE OLDHAM SIMTRONICS equipment, or for any other reason **without the prior consent of TELEDYNE OLDHAM SIMTRONICS.**

Warning

This is not a contractual document. In the best interest of its customers and with the aim of improving performance, TELEDYNE OLDHAM SIMTRONICS reserves the right to alter the technical features of its equipment without prior notice.

READ THESE INSTRUCTIONS CAREFULLY BEFORE THE FIRST USAGE: these instructions should be read by all persons who have or will have responsibility for the use, maintenance, or repair of the instrument.

This instrument shall only be deemed to be in conformance with the published performance if used, maintained, and repaired in accordance with the instructions of TELEDYNE OLDHAM SIMTRONICS by TELEDYNE OLDHAM SIMTRONICS personnel or by personnel authorized by TELEDYNE OLDHAM SIMTRONICS.

Important Information

The modification of the material and the use of parts of an unspecified origin shall entail the cancellation of any form of warranty.

The use of the unit has been projected for the applications specified in the technical characteristics. Exceeding the indicated values cannot in any case be authorized.

TELEDYNE OLDHAM SIMTRONICS recommends regular testing of fixed gas detection installations (read Chapter 7).

Before any intervention on the detector, please refer to IEC 60079-29-2 standard.

Warranty

Under normal conditions of use and on return to the factory, parts and workmanship are guaranteed for 5 years, IR sources are guaranteed for 15 years.

Waste Electrical and Electronic Equipment (WEEE directive)



European Union (and EEA) only. This symbol indicates that, in conformity with directive DEEE (2002/96/CE) and according to local regulations, this product may not be discarded together with household waste.

It must be disposed of in a collection area that is set aside for this purpose, for example at a site that is officially designated for the recycling of electrical and electronic equipment (EEE) or a point of exchange for authorized products in the event of the acquisition of a new product of the same type as before.

Table of Contents

1	Product description	1
1.1	GD10P Description	1
1.2	GD10PE Description	3
2	GD10P Technical specifications.....	5
3	GD10PE Technical specifications.....	9
4	Installation	13
4.1	Positioning	13
4.2	GD10P Fixing.....	14
4.3	GD10P Weather Protection	14
4.4	GD10P Duct or pipe mounting.....	15
4.5	GD10PE Fixing.....	17
4.6	GD10PE Weather protection/standalone mounting.....	17
4.7	GD10PE Duct or pipe mounting.....	17
4.8	External cable	19
4.9	Electrical connection.....	20
5	Commissioning	21
5.1	Visual inspection.....	21
5.2	Power up	21
5.3	Checking system functions.....	22
6	Operation	23
6.1	Analog Output Protocol.....	23
6.2	HART® Interface	24
7	Maintenance.....	29
7.1	Cleaning of optical lens/mirror.....	29
7.2	Function test.....	29
7.3	Calibration test.....	30
7.4	Re-zero.....	33
7.5	Fault finding	34

GD10-P00 and GD10-PE0

INFRARED POINT GAS DETECTOR
OPERATING MANUAL



- 8 Specific instructions for use in explosive atmospheres and operational safety35**
- 9 Marking37**
- 10 Declarations of conformity39**
- 11 Product coding43**
 - 11.1 GD10P Gas and range code45
- 12 Accessories and spare parts47**
 - 12.1 GD10P Accessories47
 - 12.2 GD10PE Accessories48
 - 12.3 Spares48

1 Product description

Compared with catalytic sensors, the GD10P and GD10PE has the following advantages:

- Presence of oxygen is not required for correct measurement, which makes the GD10P/PE suitable even in an inert gas atmosphere.
- No possibility of poisoning of the detector since no chemical reaction occurs, i.e. silicon vapors and H₂S have no effect on the detector or the measurement.
- The gas flow rate has no influence on accuracy.
- There are no saturation effects which could lead to false measurements. Thus, the detector is capable of measuring gas concentrations up to 100% vol.
- The detector has a continuous self-test function, and reports dirty optics and fault conditions to the control system.
- Total system costs can be dramatically reduced with the GD10P/PE:
- High reliability results in low test frequency and no calibration costs.

GD10P and GD10PE are sensitive to absorption bands related to carbon - hydrogen bonds.

As a result, all molecules with this type of bond are susceptible to detection. The intensity of this absorption line is, however, significantly dependent on the molecule under consideration.

In general, the larger the molecule is, the greater the absorption strength will be, and so the better it is detected.

There is therefore some measurement interference between hydrocarbon vapor compounds since their absorption bands share some spectral regions. The level of interference depends on the relative position of these absorption bands, relative to the working range of the interference filter.

1.1 GD10P Description

The GD10P has been designed with features that provide an effective response to the detection of gas hazards in a wide range of industrial environments from boiler plant rooms to offshore petrochemical installations.

These infrared gas detectors differ from all other models, because they use solid-state infrared sources. The complete opto-mechanical design and construction is so stable that an ultra-fast speed of response can be achieved whilst providing unparalleled service life and detector stability, thus saving on maintenance and service costs.

We offer the longest combined detector and IR source warranty on the market.

Supplied with worldwide performance (CSA / IECEx / ATEX / INMETRO) and hazardous area approvals.

GD10-P00 and GD10-PE0

INFRARED POINT GAS DETECTOR
OPERATING MANUAL

Suitable for use in SIL 2 and SIL 3 systems.

1.2 GD10PE Description

The GD10PE is designed for critical applications involving large volumes of air with high velocity. Places where you need fast reliable detection of low gas concentrations. GD10PE is in a class of its own.

These infrared gas detectors differ from all other models, because they utilise silicon based solid-state infrared sources. The complete opto mechanical design and construction is so stable that an ultra-fast speed of response can be achieved whilst providing unparalleled service life and detector stability, thus saving on maintenance and service costs.

We offer the longest combined detector and IR source warranty on the market.

Typical critical applications include the monitoring of air intakes for HVAC systems in living quarters or generators, and monitoring for potential gas leakages in areas with high temperatures in gas turbine packages.

The GD10PE is a stable instrument, and with a measuring range of 0 – 20%LEL the sensitivity for the GD10PE is 5 times higher than standard point detectors.

The GD10PE is designed for installation in air ducts and for mounting through walls and bulkheads in places such as pump rooms, but may also be used as a standalone point detector in places where the properties of the GD10PE is required, such as low ppm level detection.

A weather protection accessory is used for exposed detector installations.

- Duct mounted close to the intake.
- Directly mounted on an air intake.
- General outdoor locations.

The detection concept is based on the measurement of infrared radiation passing through a volume of gas.

Solid state IR-source

The silicon-based IR-source used in the GD10PE is insensitive to shock and vibration, and does not need to be replaced during the detector service life.

No false gas alarms

A false alarm, resulting in a production shutdown is extremely expensive. The dual wavelength, dual path concept, together with the electronic design, guarantees that there are no false gas alarms.

No field recalibration

Field recalibration of gas detectors is time consuming (cost) and introduces a risk of mistakes (safety). The GD10PE stays within the specifications for its service lifetime without recalibration.

The response time is among the fastest on the market, giving real world figures. We measure the response from the actual gas release, taking delays of the weather protection, initial detection, etc. into account. Trip levels down to 4%LEL combined with a response time in the range of 1 second (option) should cover even the most demanding requirements.

GD10-P00 and GD10-PE0

INFRARED POINT GAS DETECTOR
OPERATING MANUAL

2 GD10P Technical specifications

Version: 0-100%LEL Methane, 5 sec. response time.

(Specification for other types on request)

GENERAL

Detection method	IR-absorption, dual wavelength, dual path
IR-Source	Solid state IR source, 32Hz flash
Gases detected ⁽¹⁾	Detector versions for several hydrocarbons as well as CO ₂ .
Self-test	Continuous
Calibration	Factory set, no field recalibration

PERFORMANCE

Lifetime stability	±5% of full scale (FS) reading
Accuracy	±3% FS between 0-50 % reading ±5% FS between 50-100 % reading
Response time ⁽²⁾	T20 = 0.8 sec.(Optional 0.2 sec) T50 = 2.1 sec.(Optional 0.4 sec) T90 = 5 sec.(Optional 1.0 sec)
Start-up time	Less than 60 sec ³ ., full specification obtained after 30 min. warmup time

¹ The detector is intended to measure the gas for which it is indicated

² In natural diffusion and without the weather protection. The response time does not depend on the gas. This response time is available on any of the outputs of the device and is determined by the time of response of all parts of equipment within the gas detection system.

³ Sometimes, under very specific conditions, start-up can be longer. Please refer to 5.2 for additional details

GD10-P00 and GD10-PE0

INFRARED POINT GAS DETECTOR
OPERATING MANUAL

DETECTOR WARNINGS

Early Dirty Optics	55% signal attenuation
Dirty Optics	70% signal attenuation
Detector failure	Main function fault or blocked optics.
Output signal	
Standard	Current source 4 – 20 mA, max. load impedance 500 Ohm
Option	Current sink 4 – 20 mA
Maintenance	HART® interface

ELECTRICAL

Power supply	24 VDC, range 18-32 VDC
Power consumption	Approx. 3.5 W
Connection	3 wires (0.5mm ² - 1.5mm ²)
Cable entry	M20 Ex e cable gland

ENVIRONNEMENT

Storage	Temperature: -40°C to + 70°C (-40°F to +158°F) Duration: 2 years in clean atmosphere Pressure: 1013 hPa +/- 20% Humidity: 100% RH uncondensed
Operating	-40°C to + 60°C (-40°F to +140°F) ⁽⁴⁾
Humidity (operation)	100% RH uncondensed
Pressure (operation)	1013 hPa +/- 10% ⁽⁵⁾

⁴ Temperature limits for explosion protection and performance

⁵ Pressure limits for explosion protection and performance

HOUSING

Main compartment	Ex db IIC T6 Gb
Terminal compartment	Ex eb
Protection category	IP66/IP67 EN/IEC 60529 and ABNT NBR IEC 60529 ⁽⁶⁾
Housing material	Stainless steel SIS2343 (ASTM 316)
Weight	Approx. 2.9 kg (6.4 Lbs)
Dimensions	264L x 104W x 106H (mm) - 10.4 x 4.1 x 4.2 (inches)

EMC

Compliant to EN 50270 and IEC 61326-3-1 ⁷

WARRANTY

5 years full warranty on complete instrument

15 years warranty on the IR-sources

⁶ IP ratings does not mean that the equipment will detect gas during or after exposure to the defined conditions. It is also recommended to use the weather protection.

⁷ When GD10P is not directly connected to AC or DC power supply network

GD10-P00 and GD10-PE0

INFRARED POINT GAS DETECTOR
OPERATING MANUAL

3 GD10PE Technical specifications

GENERAL

Detection method	IR-absorption, dual wavelength, dual path
IR-Source	Solid state IR source, 32 Hz flash
Detection range	0-20% LEL (0-1% Vol.) methane
Gases detected ⁽⁸⁾	Hydrocarbons
Self-test	Continuous
Calibration	Factory set, no field recalibration

PERFORMANCE

Lifetime stability	±1.4%LEL
Accuracy	±1%LEL (0-10 % LEL reading) ±1.4%LEL (10-20 %LEL reading)
Response time ⁽⁹⁾	T20 = 0.8 sec. T50 = 2.1 sec. T90 = 5 sec.
Start-up time	Less than 60 sec ¹⁰ ., full specification obtained after 30 min. warmup time

⁸ The detector is intended to measure the gas for which it is indicated

⁹ In natural diffusion and without the weather protection. The response time does not depend on the gas. This response time is available on any of the outputs of the device and is determined by the time of response of all parts of equipment within the gas detection system.

¹⁰ Sometimes, under very specific conditions, start-up can be longer. Please refer to 5.2 for additional details

GD10-P00 and GD10-PE0

INFRARED POINT GAS DETECTOR
OPERATING MANUAL

DETECTOR WARNINGS

Early Dirty Optics	55% signal attenuation
Dirty Optics	70% signal attenuation Option: Dirt accumulation (2mA)
Detector failure	Main function fault or blocked optics

OUTPUT SIGNAL

Standard	Current source 4 – 20 mA, max. load impedance 500 Ohm
Option	Current sink 4 – 20 mA
Maintenance	HART® interface

ELECTRICAL

Power supply	24 V DC, range 18-32 V DC
Power consumption	Approx. 3.5 W
Connection	3 wires (0.5mm ² - 1.5mm ²)
Cable entry	M20 Ex e cable gland

ENVIRONNEMENT

Storage	Temperature: -40°C to + 70°C (-40°F to +158°F) Duration: 2 years in clean atmosphere Pressure: 1013 hPa +/- 20% Humidity: 100% RH uncondensed
Operating	-40°C to + 60°C (-40°F to +140°F) ⁽¹¹⁾
Humidity (operation)	100% RH uncondensed
Pressure (operation)	1013 hPa +/-10% ⁽¹²⁾

¹¹ Temperature limits for explosion protection and performance

¹² Pressure limits for explosion protection and performance

EXPLOSION PROOF HOUSING

Main compartment	Ex db IIC T6 Gb
Terminal compartment	Ex eb
Protection category	IP66/IP67 EN/IEC 60529 and ABNT NBR IEC 60529 ⁽¹³⁾
Housing material	Stainless steel SIS2343 (ASTM 316)
Weight	Approx. 6.5 kg
Dimensions	805L x 104W x 106H (mm)

EMC

Compliant to EN 50270 and IEC 61326-3-1¹⁴

WARRANTY

5 years full warranty on complete instrument

15 years warranty on the IR-sources

¹³ IP ratings does not mean that the equipment will detect gas during or after exposure to the defined conditions. It is also recommended to use the weather protection.

¹⁴ When GD10PE is not directly connected to AC or DC power supply network

GD10-P00 and GD10-PE0

INFRARED POINT GAS DETECTOR
OPERATING MANUAL

4 Installation



Installation shall be in accordance with the standards in force, classification of the zone, and in conformity with standard EN/IEC 60079-14, the editions in force, or with other national and/or local standards.

4.1 Positioning

Both GD10P and GD10PE detectors should be mounted where gas leakage is most likely to occur. To detect methane, which is lighter than air, inside an enclosed area the detector should be mounted high in the area to be protected or immediately above potential leakage sites.

To detect gases heavier than air, e.g. propane, the detector should be mounted below the potential leakage site.

The detector should be mounted in a place where maintenance, i.e. cleaning of the optics, is easily performed.

The detector may be mounted in areas where no oxygen is present.

The detector may be mounted in areas with strong airflow

The detector can be mounted where it could be drenched by water.

However, immersion has its limits. It assumes that the cable glands have been correctly mounted.

Furthermore, the detector will trigger an optical fault. After immersion, the detector will require cleaning because of the possible traces caused by immersion on the optical parts.

Finally, it is also important to check that the gas inlet tube is properly covered so that there is nothing getting inside.

Please note that the 4 holes in each end of the GD10PE weather protection are for water drainage, and should not be blocked.



Air velocity limits: none ¹⁵

¹⁵ Taking into account the principle of detection, a pressure variation will proportionally influence the measurement compared to the calibration one (1013HPa).

4.2 GD10P Fixing

The detector is mounted by means of a projecting mounting leg using two M8 screws and washers, or by means of the Duct Mounting Flange Kit (4 x M8 screws). The detector should preferably be mounted so that the longitudinal axis of the detector is horizontal. This will prevent accumulation of water and dust on the optics. The Weather Protection must always be oriented correctly for optimal performance.

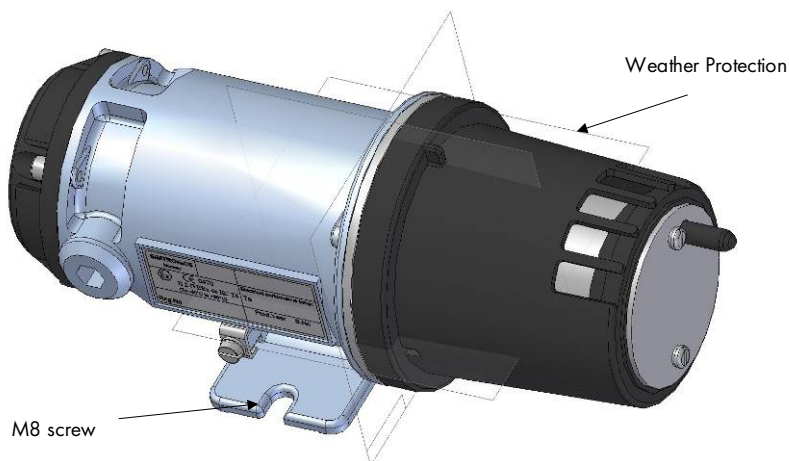

Figure 1: GD10P mounting

4.3 GD10P Weather Protection



When the GD10P is mounted outdoors, the flow direction indicator must point upwards

See "Flow Direction Indicator" in Figure 2 below. Orientation of the Weather Protection is performed as follows:

- Use a screwdriver to loosen the two screws on the Weather Protection
- Rotate the Weather Protection to correct position
- Tighten the screw with a torque of max. 0.5 Nm

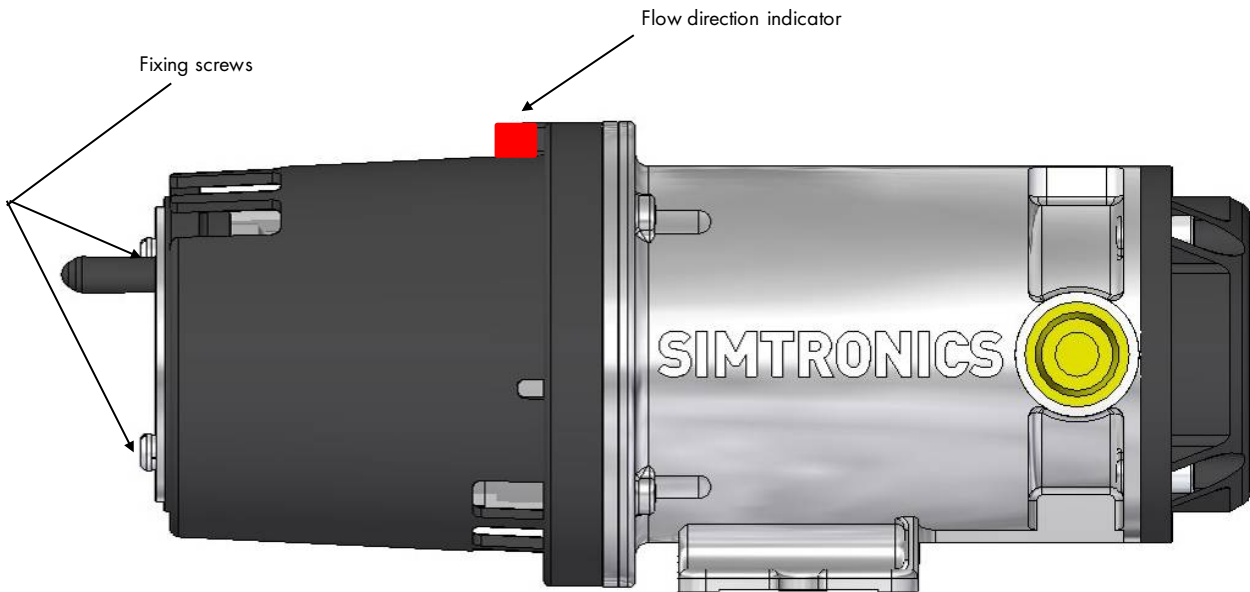

Figure 2 : Orientation of GD10P weather protection in relation to flow direction

4.4 GD10P Duct or pipe mounting

If installed in a ventilation duct or pipe, the mounting arrangement and accessories shown in Figure 3 and Figure 4 should be used. The Duct Mounting Bracket shown in Figure 3 allows the GD10P to be positioned in the core of the airflow in wide ducts or pipes.



Avoid direct light on lens and mirror if the GD10P is mounted without the Weather Protection.

In order to achieve minimum response time, the Weather Protection must be oriented with the flow direction indicator facing into the air flow. See Figure 2 and Figure 4.

The sensor must be mounted in straight parts of the duct with undisturbed airflow. Avoid areas with possible turbulent flow e.g. immediately after sharp bends or junctions.

The kit includes a modified weather protection as well as piping for functional testing.

GD10-P00 and GD10-PE0

INFRARED POINT GAS DETECTOR
OPERATING MANUAL

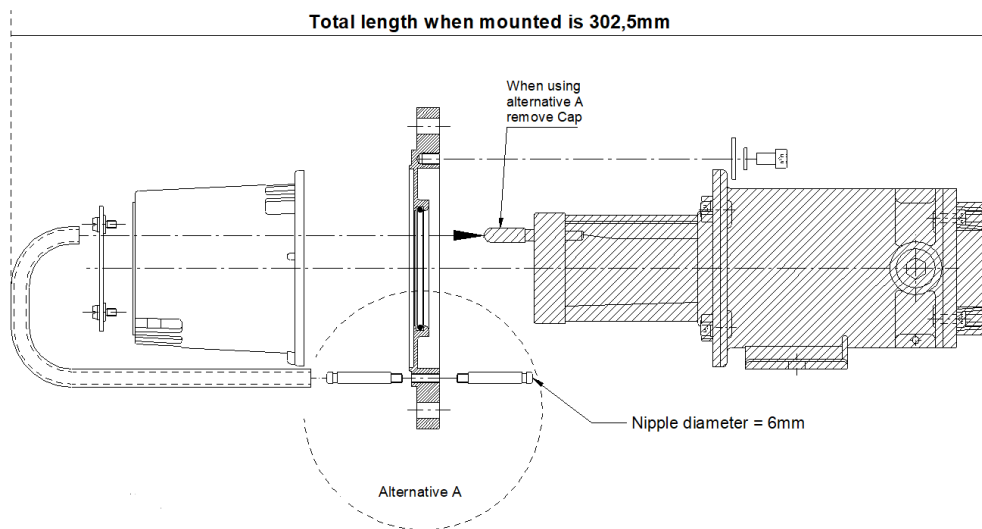

Figure 3: Exploded view, Duct Mount Flange Kit

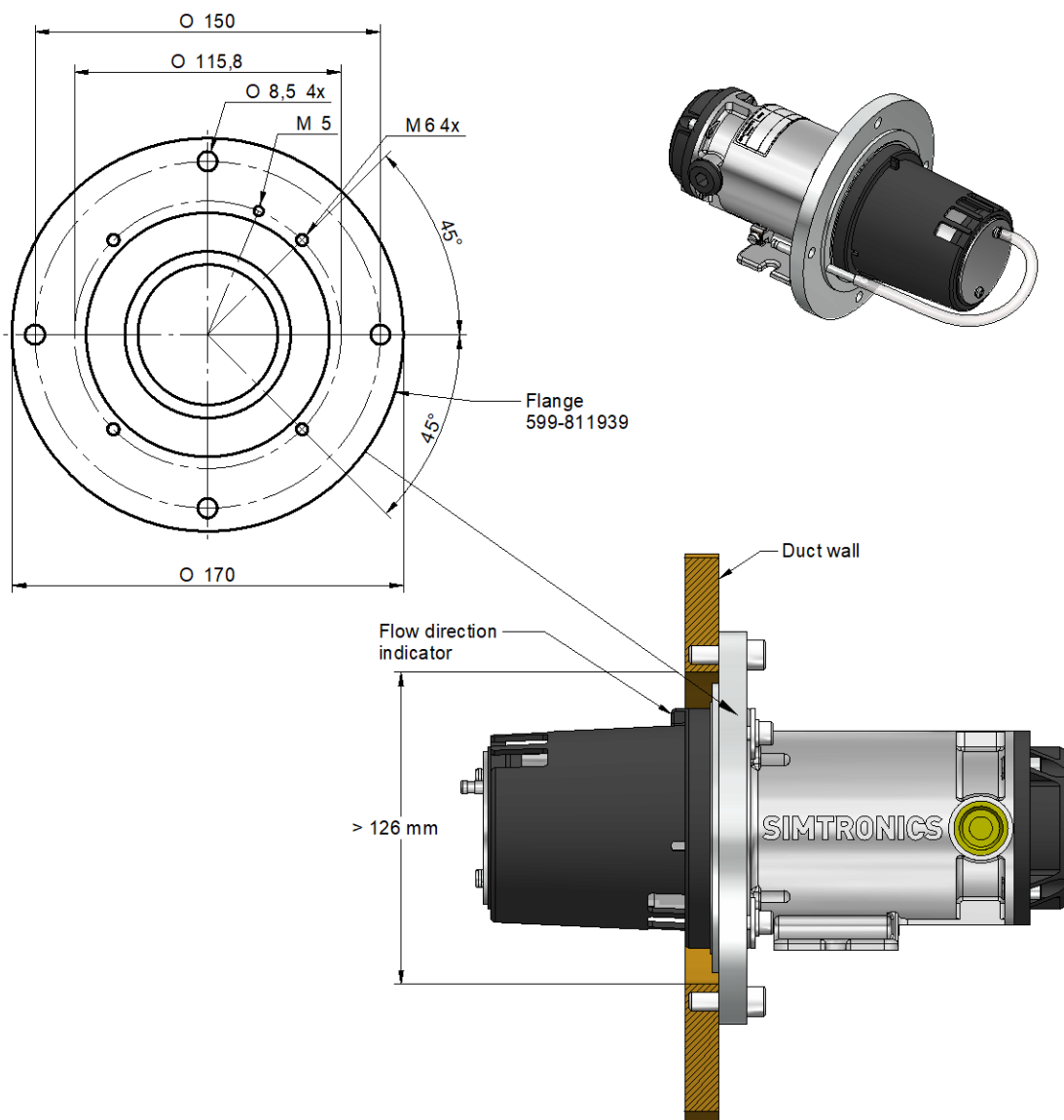

Figure 4: Ventilation duct or pipe mounting using Duct Mounting Flange Kit (Refer to Figure 3 for details)

4.5 GD10PE Fixing

The detector should be mounted so that the longitudinal axis of the detector is horizontal. This will prevent accumulation of water and dust on the optics.

4.6 GD10PE Weather protection/standalone mounting



Figure 5

4.7 GD10PE Duct or pipe mounting

By using the optional duct mounting kit, GD10PE is very suitable for monitoring ventilation air in ducts and channels. The flange is bolted to a vertical, flat surface of sufficient strength. The detector is supported by the flange only, no other fixture of the "nose" is necessary. If necessary, a flat support plate may be welded to the duct wall if the wall itself is not suitable (too weak or curved).

GD10-P00 and GD10-PE0

INFRARED POINT GAS DETECTOR
OPERATING MANUAL

The best position is at some distance behind the first filter, or grille when used for forced flow air intakes. You may also just bolt the detector as "stand alone" with the nose bracket support, but this is not advisable in harsh offshore conditions.

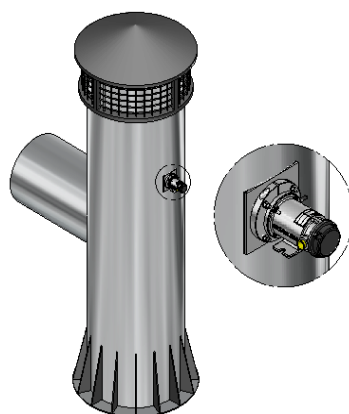
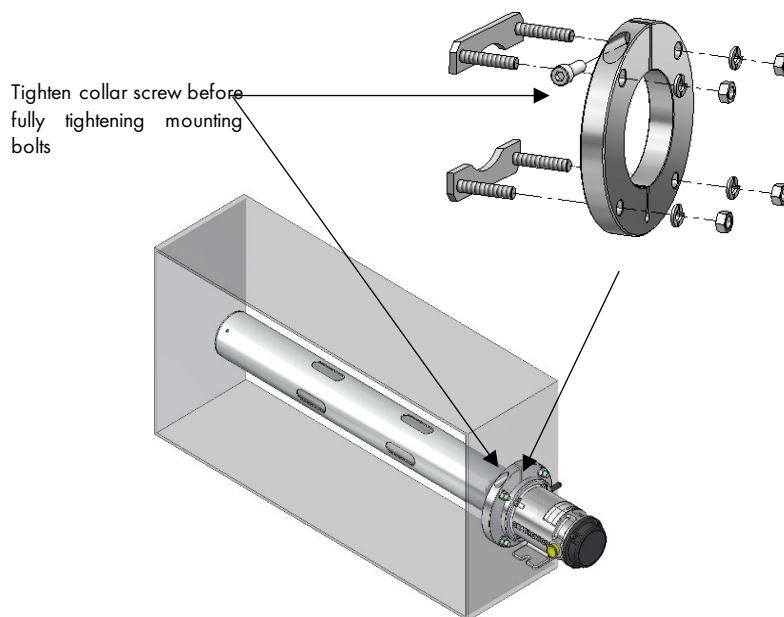

Figure 6

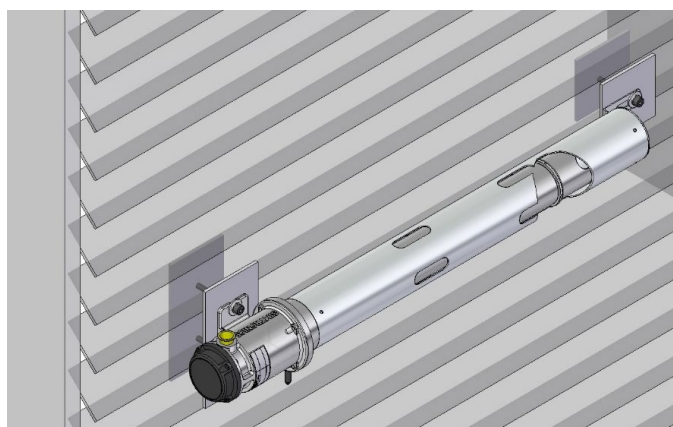

Figure 7

Foot print/bore dimensions for Mounting Flange Kit:

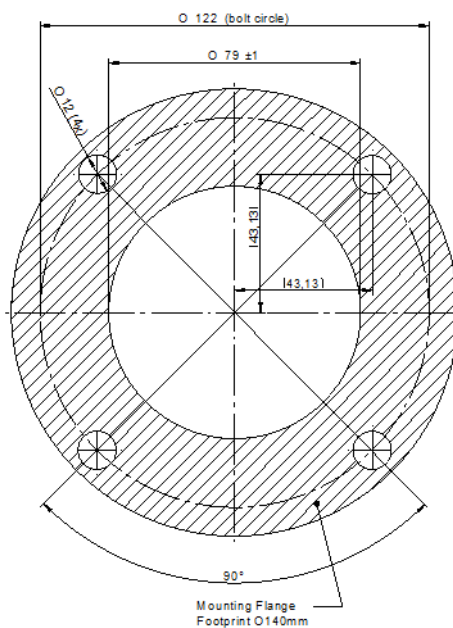

Figure 8: Flange 599-815272

For insulated ducts, it is necessary to remove some insulation.

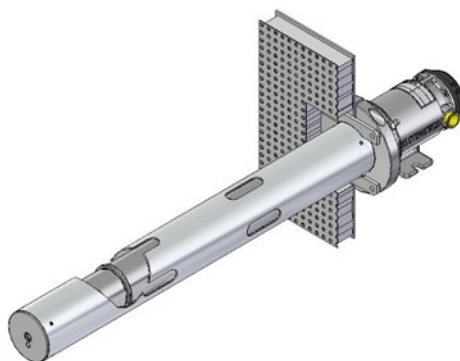

Figure 9

4.8 External cable

The cable type must be chosen in accordance with applicable regulations.

The table below indicates maximum cable lengths (2-wire) restrictions due to voltage drop over the power supply cable.

Core size cable	0,5 mm ²	0,9-1 mm ²	1,5 mm ²
Maximum length (with a 24VDC power supply)	250m	500m	750m

4.9 Electrical connection

The terminal compartment is accessible by removing the circular terminal cover (loosen the four M5 screws).

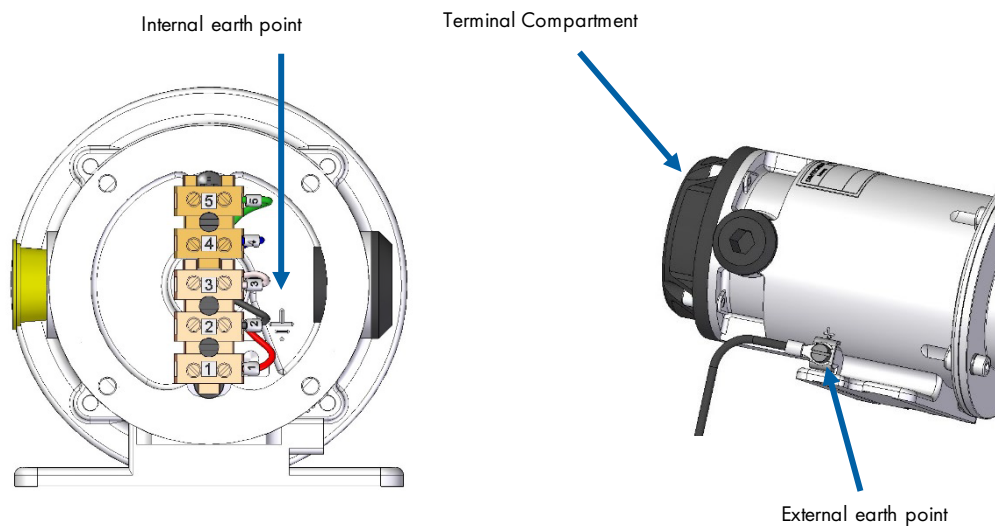

- | | |
|--------------|------------------|
| • Terminal 5 | Factory use only |
| • Terminal 4 | Factory use only |
| • Terminal 3 | 4-20 mA output |
| • Terminal 2 | 0 V |
| • Terminal 1 | +24 VDC |

Figure 10: Terminal compartment

The installation wiring enters the terminal compartment via a single M20 Ex e cable gland, which can be mounted on either side of the compartment. The unused entry is blanked with an Ex e cover.



The detector housing must be connected to local ground via the external earth point. The wire should be minimum 4 mm² (8 AWG) and as short as possible.

The shield of the cable should be connected at both sides (at detector side and at the controller). The shield must be terminated to local ground via the cable gland at the detector and must not enter the terminal compartment.

5 Commissioning

5.1 Visual inspection

The following should be checked before initial powering up:

- The axis of the detector shall be horizontal,
- Correct cable gland installation,
- Electrical connection,
- Electrical grounding,
- Termination of cable shield,
- Orientation of the weather protection,
- All bolts and screws are tight.

Check the presence and good condition of the O-ring (no cracks, cuts, good elasticity) on the back cover. Make sure that the flat support surface is clean, properly greased and that it does not show any visible scratches or "knocks".

Please refer to Chapter 4 "Installation" for details.

5.2 Power up

Ensure that system wiring and control system are in working order before powering the detector. The startup period takes about 60 seconds, a functional self-test is performed during this time. When the self-test is completed the detector turns over to measuring mode. The 4-20mA output will stay at 0mA during the 60 seconds startup period and 4mA (if no gas is present) in measuring mode. The graph on the left shows the reading of the 4-20mA analog output during startup period.

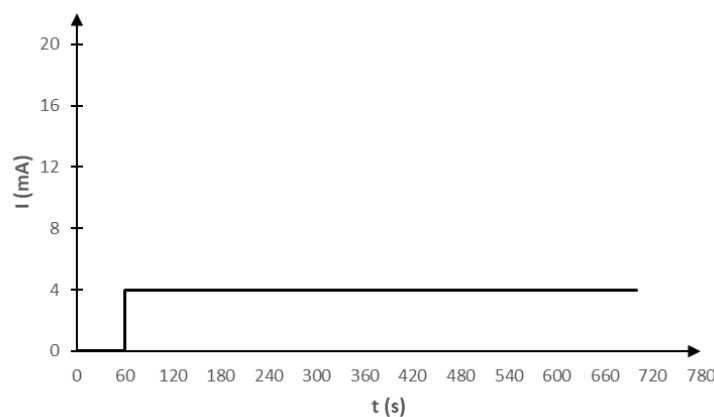

Figure 11: Analog output during normal startup



Startup period can be up to 10 minutes under very specific conditions. This corresponds to the temperature adjustment time of the different components.

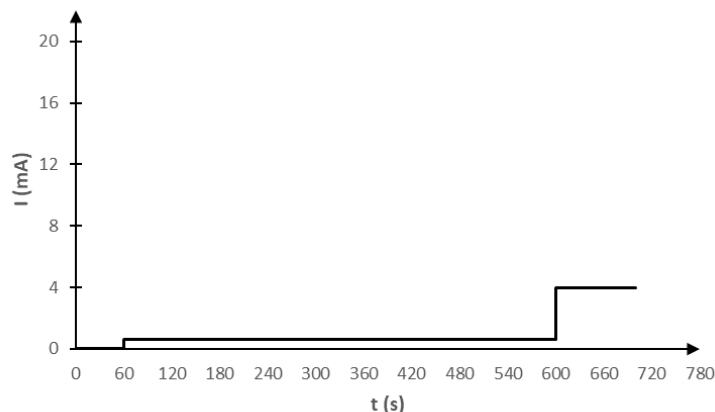

Figure 12: Analog output during specific startup conditions



If the analog output of the detector stays at 0.6mA after 10 minutes then the detector could have a zero drift issue. This issue can be solved by applying a "Re-Zero" to the detector. This procedure is described in section 7.4.

5.3 Checking system functions



Full specification obtained after 30 min. warmup time

The GD10P is factory calibrated and does not require any adjustments before operation. A check prior to putting into service should however consist of:

- 1) Clean the optical surfaces.
The detector may have been collecting dirt after being initially installed. It is thus crucial to clean the optical parts before testing the detector (refer to Paragraph 7.1 "Cleaning of optical lens/mirror").
- 2) Do a gas test.
To make sure the detector works fine you should as a minimum do a function check as described in paragraph 7.2 "Function test".

Optionally you may do a full calibration test as described in paragraph 7.3 "Calibration test".

6 Operation

6.1 Analog Output Protocol

Gas reading and fault signals are given through the 4-20mA current loop interface. The table below shows the analog output level for the various conditions.

Status	Output	Comment
Detector fault	< 0.6 mA ^(*)	No detection
Dirty Optics Warning (70% signal reduction)	1 mA ^(*)	No detection
Early Dirty Optics Warning (55% signal reduction)	2 mA ^(*)	Detector will still output gas concentration if it is greater than 7% of range (FS)
≤ -10% of range	0.6 mA	Default
0 % of range	4 mA	0%
10 % of range	5.6 mA	10% Alarm if threshold reached
30 % of range	8.8 mA	30% Alarm if threshold reached
50 % of range	12 mA	50% Alarm if threshold reached
70 % of range	15.2 mA	70% Alarm if threshold reached
90 % of range	18.4 mA	90% Alarm if threshold reached
100 % of range	20 mA	100% Alarm
>100% of range	Disabled ^(*)	Overscale

^(*) Shows default factory settings. Can be configured via HART® terminal

6.2 HART® Interface

6.2.1 Introduction

TELEDYNE OLDHAM SIMTRONICS GD10P/PE detector supports HART® version 7.

For proper operation between GD10P/PE and the HART® communicator, a dedicated Device Descriptor (DD) should be loaded onto the communicator. If such DD is not present, the communicator will offer a generic interface, and the list of available functions may be limited.

The proper DD for GD10P/PE can be downloaded from HART® Foundation website <https://www.fieldcommgroup.org/registered-products>. (product name:GD10P). The loading of the DD onto a specific communicator must be done according to the relevant user guide for that communicator.



The loss of HART communication is not related to safety.

6.2.2 Connection

For access to the detectors HART® features, connect an industry standard HART® communicator as shown in the following figures depending on the type of analog interface (source or sink).

Note that for the HART® communication to work properly, a minimum loop resistance is required in the current loop. The actual value of the serial resistance in the diagrams below may vary depending on the rest of the resistance in the loop.

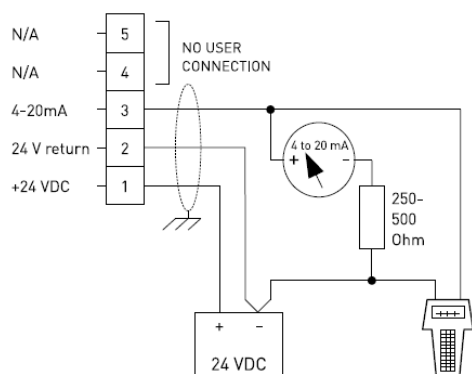

Figure 13: HART® terminal connection
for source variant

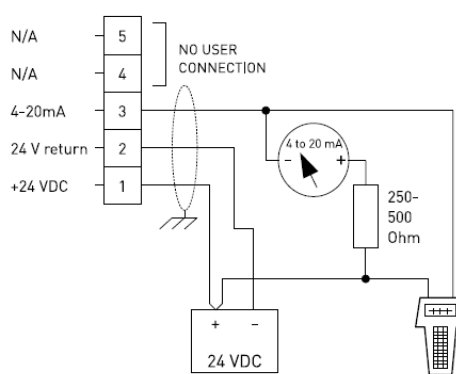
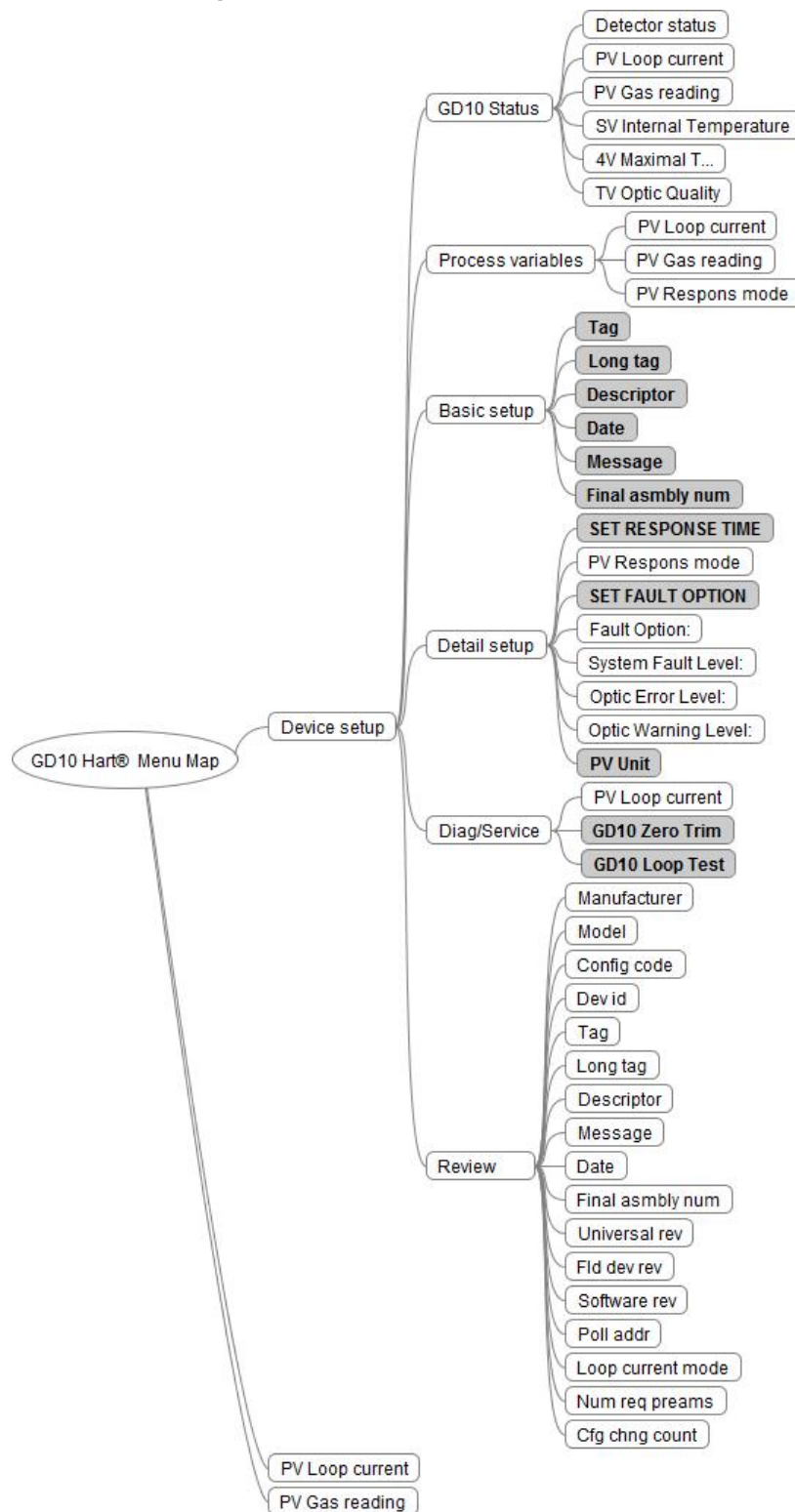

Figure 14: HART® terminal connection
for sink variant

6.2.3 HART® Menu Map



This menu map shows a non-exhaustive list of available commands in the HART® interface of GD10.

For more information about the complete list of HART available commands, please refer to the **GD10 Gas Detector: HART Specification NOSP18031**.

Most of the commands are only requests to read information from the detector. The commands shaded as grey with bold text gives the operator possibility to make changes to individual parameters, and these commands are described further in the following sections.



Some of the following commands require a maintenance password to be executed.

Default password is: SIMTRONICS

Use command #LINSIMTRONICS to log as a maintenance user.

This mode is automatically deactivated after 10 minutes without further action.

6.2.4 Detailed description of selected commands

When one of the following commands are activated, the operator is navigated to one or several data input screens where detailed data can be entered, or predefined options selected. Detailed navigation between the commands is not explained, as this is part of the user interface of the actual HART® communicator.

6.2.4.1 TAG (Basic setup)

The operator can write an alphanumeric text, max 8 characters. Default is "GD10P".

6.2.4.2 Long tag (Basic setup)

The operator can write an alphanumeric text, max 32 characters. Default is "Long Tag".

6.2.4.3 Descriptor (Basic setup)

The operator can write an alphanumeric text, max 16 characters. Default is "GD10P".

6.2.4.4 Date (Basic setup)

The operator can write a date on the format MM/DD/YY. Default is "**/**/**".

6.2.4.5 Message (Basic setup)

The operator can write an alphanumeric text, max 32 characters. Default is "OLDHAM SIMTRONICS".

6.2.4.6 Final assembly num (Basic setup)

The operator can define a number between 0 and 16777215.

6.2.4.7 SET RESPONSE TIME (Detailed setup) ¹⁶

The operator can choose between two response modes: "fast" (T90=1sec) and "normal" (T90=5sec).

6.2.4.8 SET FAULT OPTION (Detailed setup) ¹⁷

The operator can choose between three options according to the following table.

Option	Detector fault	Dirty Optics	Early Dirty Optics (see note 1)
OP0 (default settings)	0.6 mA	1 mA	2 mA
OP1	1 mA	2 mA	3 mA
OP2 (User selectable)	1 (0.6 mA) 2 (1 mA) 3 (2 mA) 4 (3 mA)	1 (0.6 mA) 2 (1 mA) 3 (2 mA) 4 (3 mA)	1 (no warning) 2 (1 mA + pulsing) 3 (2 mA) 4 (3 mA)

Note 1: If in "Early Dirty Optics" state, the detector will switch to standard output level when gas reading is >7% of detection range.

After a reconfiguration, it is recommended to restart the detector and verify the new settings by simulating different alarm/warning states. A current meter may be used to read the level at the analog output.

6.2.4.9 PV unit (Detailed setup)

This command is no longer supported.

6.2.4.10 GD10 Zero Trim (Diag/Service) ¹⁸



This function should be activated by special trained operators. If zero trimming is not done in a controlled way, the performance of the detector can be reduced. Also, prior to launching this function, read the detailed descriptions in section 7.4.

When this function is activated, the operator gets on-line instructions on how to support the function. If a zero low alert current below 4mA was configured, the analog output will drop down to that value to indicate the on-going process, which takes about 3-4 minutes to complete.

^{16 / 17 / 18} These commands require a maintenance password

The analog output returns to the actual zero (4mA) when zeroing process is completed. Zeroing will not take place if the ambient temperature is outside a specific temperature range (+16°C/+26°C). If the Zero level is not improved after the zeroing, the reason is that the zero drift is over the allowed limit for field trimming.

6.2.4.11 GD10 Loop Test (Diag/Service)

A fixed analog output level can be used to test the analog output loop. Such fixed analog output level can be obtained with this function. The operator can choose one of the pre-set levels, or specify a user defined level.

7 Maintenance

The GD10P and GD10PE has no user adjustable parts. It is not recommended to open the GD10P, as this will change the internal atmosphere, and the initial calibration could be affected. Opening the GD10P/PE voids all warranty offered at the time of sale.



Periodicity of the maintenance must be adjusted (reduced) when the equipment is exposed to conditions defined by the IP ratings.

7.1 Cleaning of optical lens/mirror

Remove the weather protection by unscrewing the front cover plate (two screws), use a soft, clean tissue to rub off the contamination. The window and mirror are made of sapphire, which is highly resistant to scratching. Make sure that the whole optical surface is clean.



For difficult contaminants the mirror and lens can be cleaned with an equal-part mixture of isopropyl alcohol and water. Do not perform any testing of the detector before this solution has dried and residues have been wiped away.

7.2 Function test

In order to perform function test of the detector, a test gas can be applied through a 6 mm test nozzle on the front of the Weather Protection housing as shown in the figure and observe the effect on the detector 4-20mA analog output or through the control system.

This is a simple test to verify the main function of the detector, please note the actual reading may be substantially lower than the calibration gas concentration due to leaks/ventilation of the weather protection. As long as the detector responds to the gas, the function of the detector is verified.

- 1) Clean the optical surfaces
- 2) Verify that the zero point (at no gas) is within the tolerance for the detector. Normal readings should be below 4.5mA

GD10-P00 and GD10-PE0

INFRARED POINT GAS DETECTOR
OPERATING MANUAL

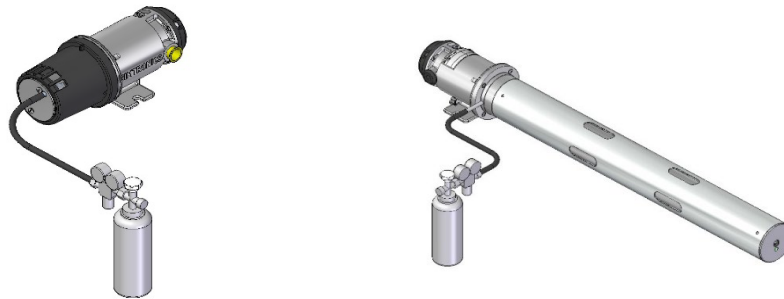

- 3) Apply gas as shown. If there is no air movement, a test gas flow of minimum four liters per minute will give approximately the same value as the test gas.

If there is an air movement of 0.5 m/sec., the test gas flow has to be increased (up to 20 liters per minute) to get a reasonable reading. Covering the ventilation grille will also help getting a higher reading. However, you may not be able to reach the actual gas concentration, any reading above 10% is OK.

7.3 Calibration test



A calibration test is not required to verify the correct function of the detector. Normal maintenance of the detector is covered by the simple function tests described in sections 7.1 and 7.2. The following calibration test is only applicable if it is required by regulations or in cases where you need to verify system performance during commissioning or similar thorough testing.

The GD10P/PE detectors have a fixed calibration from the factory. A calibration test is thus just a test. There are no means to change the calibration on-site.

In order to perform calibration test, two alternatives can be used depending on the material on site.

7.3.1 Using Sample Flow Housing

First alternative is to use a calibrated gas and apply it via a Sample Flow Housing (reg. no. 499-810874 for GD10P or 499-815733 for GD10PE).

- 1) Remove the Weather Protection and clean the optical surfaces.
- 2) Attach the Sample Flow Housing. This is just press fit with two o-ring seals. Please note that the seals are not equally sized, so note the location of the test nozzle close to the detector housing.
- 3) Apply a certified test gas of approx. 50 % of GD10P/PE calibrated range as shown in the drawing. The test gas should be the same as the target gas. Humidity of the test gas is: 0-100% RH uncondensed.

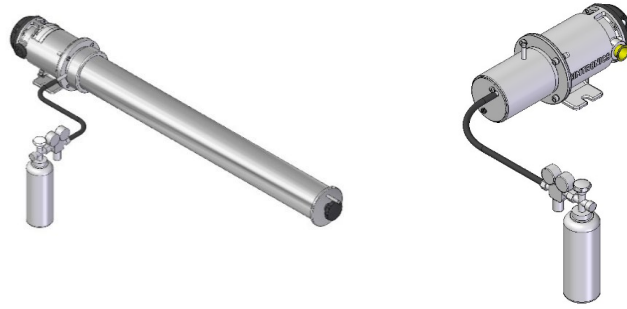

7.3.2 Using Gas Test Socket

Second alternative is to use a calibrated gas and apply it via a Gas Test Socket (reg. no. 599-818154 for GD10P).

- 1) Remove the Weather Protection and clean the optical surfaces.
- 2) Put the Weather Protection back in place on GD10P. Insert the Gas Test Socket over the Weather Protection. The notch of the Socket must be aligned with the flow direction indicator of the Weather Protection.
- 3) Apply a certified test gas of approx. 50 % of GD10P calibrated range as shown in the drawing. The test gas should be the same as the target gas. Humidity of the test gas is: 0-100% RH uncondensed.

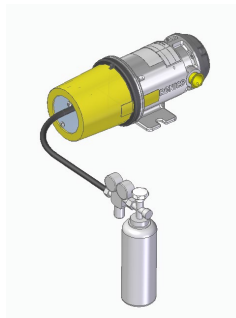

At 40°C, 50% RH means %volume H₂O = 3.5%.

Gas flow should be approximately 1 liter/minute.

Wait approximately 2 min. to ensure that the Sample Flow Housing or the Gas Test Socket is completely filled with gas.

Read detector output or read output through the gas detection system. The reading should be within the tolerance of the detector plus the tolerance of the test gas. In practical terms this is the gas concentration +/- 10% of full scale.

Although no further calibration is required during the lifetime of the product, it is recommended to make this calibration test once a year.

As the detector is an optical measurement device, it is not damaged by an overscale.

GD10-P00 and GD10-PE0

INFRARED POINT GAS DETECTOR
OPERATING MANUAL



Do not forget to remove the Gas Test Socket when calibration test is over.

7.4 Re-zero

This maintenance activity should only be carried out by special trained operators. If this is not done in a controlled and proper way, the performance of the detector can be reduced.



Note that this operation must be done when the detector is in the following temperature range +16°C/+26°C. TELEDYNE OLDHAM SIMTRONICS has no responsibility for faults introduced by on-site re-zeroing

The GD10P/PE detector is calibrated and temperature tested in a controlled environment at the TELEDYNE OLDHAM SIMTRONICS factory. No further calibration is required during the life time of the product, as the zero point and calibration will stay inside the given tolerances. This implies that slight offsets from the zero point of 4.0mA (0%LEL) is to be expected and values up to 4.5mA (for GD10P) or 5.0mA (for GD10PE) at room temperature are within specification.

In some environments with excessive heat and/or vibration we have noticed that a higher percentage of the detectors develop an offset outside the specified tolerances. These detectors should normally be returned to the factory for service. An alternative is to do this re-zeroing on site with a dedicated hand held terminal, or HART® communicator.



Note that "on site" does not mean "in service". Before concluding that re-zero is necessary, proper cleaning of the detector should be done (even an invisible layer of oil on the lens or mirror can have negative impact on the zero-point reading). Then, before re-zeroing is conducted, the detector should be removed from the system and moved to a controlled environment in a workshop

7.4.1 Test of zero-point in the workshop

Prior to conducting a re-zero, a controlled checking of the zero level should be done with a sample flow housing and nitrogen test gas (clean instrument air may be used if nitrogen is unavailable).

- 1) Clean the sensor optics again, both mirror and lens.
- 2) Attach a Sample Flow housing (P/N 499-810874 for GD10P or 499-815733 for GD10PE)
- 3) Connect the power supply and HART® terminal (according to section 6.2.2) or a Hand Held terminal according to its separate operating manual.
- 4) Switch on power and wait approx. 2 minutes until the output has stabilized.
- 5) Wait approximately 30 minutes until warm up is over.
- 6) Apply nitrogen gas to the Sample Flow housing
- 7) Read current loop output
- 8) If output is outside specification, then a re-zero may be applicable

7.4.2 Re-zeroing with HART® communicator

See section 6.2.4.10.

7.5 Fault finding

The internal microprocessor performs continuous self-testing of optical and electronic functions.

If a fatal error should occur in the electronics or optics, the processor will generate a 0mA output signal, indicating detector failure. The detector should then be checked according to flow chart on the left. Do not return the instrument to the supplier for repair if this test has not been performed.

If the IR transmission in the optical path is attenuated to 50-70% of its original value, the output signal will go down to Early Dirty Optics (see section 6.1 for further details).

If the IR transmission is further attenuated, the output signal will go down to Dirty Optics (fault). In this condition the detector will not detect gas (see section 6.1 for further details).

If the optics are contaminated, wipe them with a clean cloth and mild detergent according to instructions in section 7.1. The optics must be cleaned even if they appear not to be contaminated.

A signal output equal to 0 mA can be due to a power supply failure. Check first that voltage supply at detector terminal is between 18VDC and 32VDC.



Avoid direct light on lens and mirror if testing without the Weather Protection.

Ensure that no gas is present in the measuring chamber when testing.



A temperature fault is output if ambient temperature is outside -85°C/+85°C.

8 Specific instructions for use in explosive atmospheres and operational safety

8.1.1.1 General comments

GD10P/PE gas detectors comply with the requirements of European Directive ATEX 2014/34/UE and INMETRO Ordinance No. 179 of 2010 relating to gas explosive atmospheres.

The information described below must be taken into account and fulfilled by the site manager. Refer to ATEX 1999/92/EC European Directive on requirements for improving the safety and health of workers potentially at risk from explosive atmospheres.

The HART output has not been evaluated for Performance testing to Standard C22.2 No. 152.

8.1.1.2 Warnings

Do not open when energized. Read user manual (cable glands).

8.1.1.3 Cable Entries

Cable glands and accessories (plugs, adaptors, etc.) shall be flameproof certified "db" or "eb" for use in gas atmospheres and Ingress Protection will be greater or equal to IP 66. They shall be of M20x1.5 type according to ISO965-1 and ISO965-3 standards. Installation must comply with ABNT NBR IEC/EN 60079-14 standard (current edition) and, if necessary, additional requirements of domestic or national regulations that apply to the place of installation. Cables used shall have an operating temperature range equal or greater than 80 °C.

8.1.1.4 Installation

When the weather protection is mounted, the detector shall be installed horizontally ($\pm 15^\circ$) with the flow direction indicator looking upward (see Figure 2).

8.1.1.5 Special condition of use:

Repairs of the flameproof joints must be made in compliance with the structural specifications provided by the manufacturer. Repairs must not be made on the basis of values specified in tables 1 and 2 of EN/IEC 60079-1.

For CH₄ use, GD10P detector shall be used with calibration cap to ensure response time.

GD10-P00 and GD10-PE0

INFRARED POINT GAS DETECTOR
OPERATING MANUAL

8.1.1.6 Functional safety certification:

For all information related to the safety function of the GD10P/PE gas detectors, please refer the safety manual NOSP18157.

9 Marking

The GD10P/PE identification labels are shown in the figures below, as example.

ATEX/IECE_x/INMETRO/MED markings (combustible gases version)

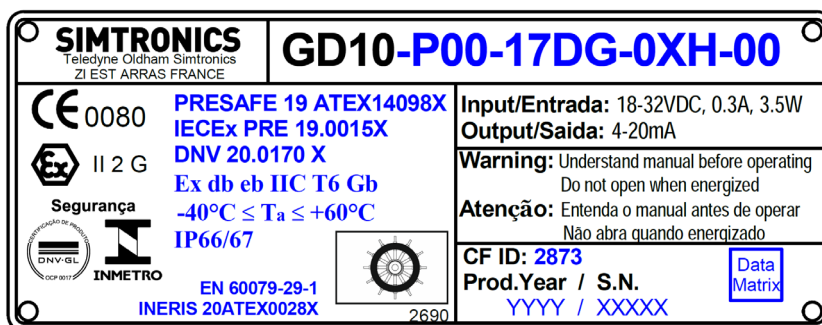

ATEX/IECE_x/INMETRO/MED markings (CO₂ version)

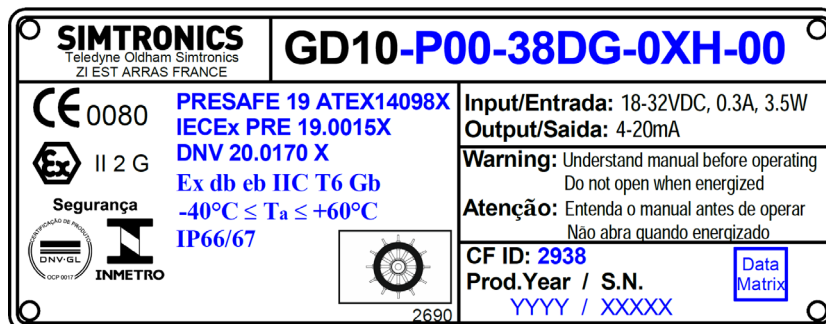

CSA marking (CO₂ version)

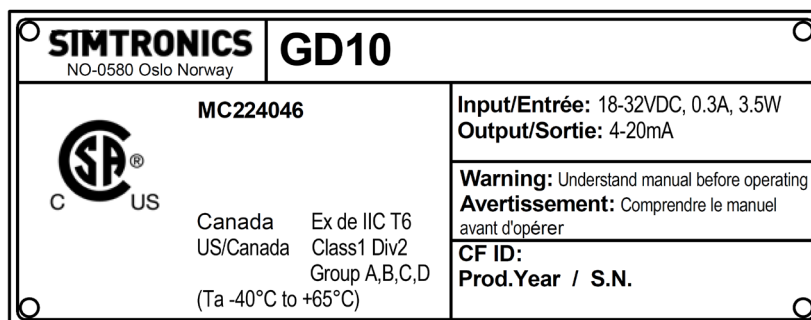

GD10-P00 and GD10-PE0

INFRARED POINT GAS DETECTOR
OPERATING MANUAL

CSA marking (combustible gases version)

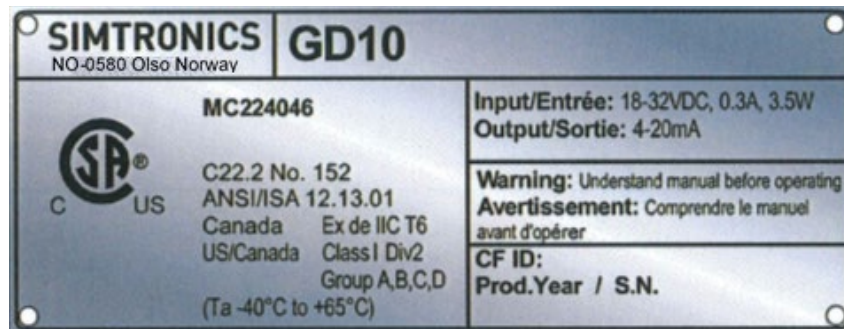

10 Declarations of conformity



TELEDYNE
OLDHAM SIMTRONICS
Everywhereyoulook™

DECLARATION UE DE CONFORMITÉ
EU CONFORMITY DECLARATION

Réf : UE_GD10P_PE_rev14.doc

Nous,
We,
 **Teledyne Oldham Simtronics S.A.S.**, ZI Est, 62000 Arras France

 Déclarons, sous notre seule responsabilité, que le matériel suivant :
Declare, under our sole responsibility that the following equipment :

Gas detectors GD10-P00 and GD10-PE0
Détecteurs de gaz GD10-P00 et GD10-PE0

 Est conçu et fabriqué en conformité avec les Directives et normes applicables suivantes :
Is designed and manufactured in compliance with the following applicable Directives and standards:

I) Directive ATEX 2014/34/UE dated from 26/02/14: Explosive Atmospheres

Directive Européenne ATEX 2014/34/UE du 26/02/14: Atmosphères Explosives

Applied Standards **EN 60079-0: 2018 ; EN 60079-1: 2014 ; EN 60079-7: 2015**
Normes appliquées **EN 60079-29-1: 2016 ; EN 50271: 2018**

EC type examination certificate: **PRESAFE 19 ATEX 14098X**
Attestation CE de Type du matériel **INERIS 20ATEX0028X**

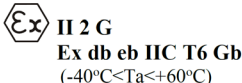
Category (catégorie) / Marking (marquage): 

Production Quality Assurance Notification: **INERIS 00ATEXQ403**
Notification Assurance Qualité de Production

Issued by the Notified Body n°0080: **INERIS, Parc Alata**
Délivré par l'Organisme notifié numéro 0080 **60550 Verneuil en Halatte France**

II) European Directive EMC 2014/30/UE dated from 26/02/14: Electromagnetic Compatibility

Directive Européenne CEM 2014/30/UE du 26/02/14: Compatibilité Electromagnétique

Harmonised applied Standard: **EN 50270: 2015 for type 2**
Norme harmonisée appliquée

 Ce matériel ne doit être utilisé qu'à ce pour quoi il a été conçu et doit être installé en conformité avec les règles applicables et suivant les recommandations du fabricant.
This equipment shall be used for the purpose for which it has been designed and be installed in accordance with relevant standards and with manufacturer's recommendations.

A Arras, le 14/10/2020 / Arras, on October 14th, 2020

Teledyne Oldham Simtronics S.A.S.
Z.I. EST - C.S. 20417
62027 ARRAS Cedex - FRANCE
Tel. : +33(0)3 21 60 80 80
www.teledyneGFD.com

AM. Dassonville
Certification Responsible



Page 1 | 1

 TELEDYNE OLDHAM SIMTRONICS Everywhereyoulook™	UE DECLARATION OF CONFORMITY TO TYPE FOR GD10P
	In accordance with the Marine Equipment Directive (MED) 2014/90/UE, as amended Product Serial Number:

Manufacturer's, or his authorized Representative's name & address:
TELEDYNE OLDHAM SIMTRONICS- ZI EST – CS 20417- 62027 ARRAS CEDEX

In compliance with Article 16 of the Council Directive 2014/90/UE, the Marine Equipment Directive, as amended. We declare under our sole responsibility that the products detailed below conform to type, as described in the EC Type Examination certificate:

MEDB0000029 rev 6, issued by DNV.GL (NB 0575) on October 2nd, 2020

Product Types: Gas Detector

Product Descriptions: IR Gas Detector GD10-P

Serial Number (S/N): See Head of document

We further declare also that these products have been marked for their identification in accordance with Article 9 of the Marine Equipment Directive, after having been duly authorized by the EC Notified Body, the identification number of whom is stated below.

Modules for Production conformity assessment, within which the EC Declaration of conformity is issued:
Module D - Production-Quality Assurance,
Quality System Approval Certificate N° SMS.MED2.D_127472_A.1, issued by Bureau Veritas (NB 2690) on Nov. 12th, 2020

Limitation/Application:
The equipment are found to comply with following location/application dependent requirements:

- EMC: Bridge and open deck zone (ref. IEC 60092-504 (2016) table 1 item 19-20)
- Enclosure: Open decks (IP56) (ref. IEC 60092-201 table 5)
- Vibration: General applications (ref. IEC 60092-504 (2016) table 1 item 10)
- Temperature: Location (-25°C to +65°C) (ref. IEC 60092-504 (2016) table 1 item 6-7), low temp. tested to -40°C, high temp. limited to +65°C due to EX-classification

REGULATIONS and STANDARDS complied with:

(EU) 2020/1170, item No. MED/3.54. SOLAS 74 as amended,
Regulation II-2/4 & VI/3 and FSS Code 15

EN 60079-0 (2012) incl. A11 (2013)
EN 60079-29-1 (2016)
IEC 60092-504 (2016)
IEC 60533 (2015)

MARKING & IDENTIFICATION AFFIXED TO THE PRODUCTS:

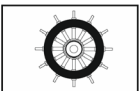
 2690	Prod. Year : YYYY Serial Number : YY-XXXXX (The first 2 digits indicate the year of manufacture)
---	--

Issued at ARRAS FRANCE, on

Anne Marie Dassonville
Certification Responsible



GD10P_MED DoC_F2019_01_F.docx

Material Declaration

<Date of declaration>

Date	2018-11-15
------	------------

<MD ID number>

MD-ID-No.	GD10-P00-09DG-0XH-00-MD-18
-----------	----------------------------

<Supplier (respondent) information>

Company name	Oldham SAS
Division name	Gas & Flame Detection
Address	Oldham, ZI Est, Rue Orfila, CS 20417, 62027 Arras Cedex
Contact person	Thibault Fourlegnie
Telephone number	+33 (0) 3 21 60 80 13
Fax number	
E-mail address	tfourlegnie@mmm.com
SDoC ID-No.	SRR-18-GD10-P00-09DG-0XH-00

<Other information>

Remark 1	
Remark 2	
Remark 3	

<Product information>

Product name	Product number	Delivered unit		Product information
		Amount	Unit	
GD10P	GD10-P00-09DG-0XH-00	1	piece	Designed for the detection of explosive gases, toxic gases or oxygen

<Material information>

This materials information shows the amount of hazardous materials contained in	Unit
1	piece

Table	Material name	Threshold level	Present above threshold level	If yes, material mass		If yes, information on where it is used	
				Yes/No	Mass		Unit
Table A** (materials listed in appendix 1 of the Convention)	Asbestos	0.1%*	No				
	Polychlorinated biphenyls (PCBs)	50 mg/kg	No				
	Ozon depleting substance	Chlorofluorocarbons (CFCs)	no threshold level	No			
		Halons		No			
		Other fully halogenated CFCs		No			
		Carbon tetrachloride		No			
		1,1,1-Trichloroethane		No			
		Hydrochlorofluorocarbons		No			
		Hydrobromofluorocarbons		No			
		Methyl bromide		No			
Bromochloromethane	No						
Anti-fouling systems containing organotin compounds as a biocide	2,500 mg total tin/kg	No					
Table B** (materials listed in appendix 2 of the Convention)	Cadmium and cadmium compounds	100 mg/kg	No				
	Hexavalent chromium and hexavalent chromium compounds	1,000 mg/kg	No				
	Lead and lead compounds	1,000 mg/kg	Yes	220,888	mg	Lead -22% of all PCBA's by mass	
	Mercury and mercury compounds	1,000 mg/kg	No				
	Polybrominated biphenyl (PBBs)	50 mg/kg	No				
	Polybrominated diphenyl ethers (PBDEs)	1,000 mg/kg	No				
	Polychloronaphthalenes (Cl >= 3)	50 mg/kg	No				
	Radioactive substances	no threshold level	No				
Certain shortchain chlorinated paraffins	1%	No					
Annex II*** (Additional materials)	Perfluorooctane sulfonic acid (PFOS)	10 mg/kg****	No				
	Brominated Flame Retardant (HBCDD)	100 mg/kg	No				

*Please refer to footnote 18 on the "Form of Material Declaration" in the IMO Guidelines Resolution MEPC.269(68).

**Hong Kong International Convention for the Safe and Environmentally Sound Recycling of Ships, 2009 (SR/CONF/45).

***Regulation EU No. 1257/2013 of the European Parliament and of the Council of 20 November 2013 on Ship Recycling and amending Regulation EC No. 1013/2006 and Directive 2009/16/EC

****EMSA's Best Practice Guidance on the Inventory of Hazardous Materials, dated 2016-10-28

*****Concentrations of PFOS above 10 mg/kg (0.001% by weight) when it occurs in substances or in preparations or concentrations of PFOS in semi-finished products or articles, or parts thereof equal to or above 0.1% by weight calculated with reference to the mass of structurally or micro-structurally distinct parts that contain PFOS or for textiles or other coated materials, if the amount of PFOS is equal to or above than 1 µg/m² of the coated material.

Important Notice: The content and specifications of this form may not be changed or amended. Any changes or amendments by others than the author of this form constitute a breach of copyright law.

Supplier's Declaration of Conformity for Material Declaration Management

- 1) **SDoC No.:** SRR-18-GD10-P00-09DG-0XH-00
- 2) **Issuer's name:** Oldham SAS
Issuer's address: Oldham, ZI Est, Rue Orfila, CS 20417, 62027 Arras Cedex |
- 3) **Object(s) of declaration:** 1) GD10P
2) _____
3) _____
4) _____

- 4) The object(s) of the declaration described above is/are in conformity with the following documents:

- 5) **Applicable Regulations or other stipulated requirements and documents**

Document No.	Title	Edition	Date of issue
1	Regulation (EU) 1257/2013 of the European Parli	1	2018-11-13
2	GD10- DOC- Materials Report	1	2018-11-13

- 6) **Additional Information:** Total amount of Lead in assembled printed circuit board-
22% by mass.

Signed for and on behalf of: OLDHAM SAS

ARRAS
Place of issue

26.11.2018
Date of issue

7) T. FOURLEGNIE, Managing Director
Name, function

OLDHAM S.A.S.
Capital 20 064 825 € - RCS ARRAS 433 953 379
A.P.E. 2651B - T.V.A. Intra: FR 63 433 953 379
Rue Orfila - Z.I. Est - CS 20417
62027 ARRAS Cedex
Tél.: 03.21.60.80.80 - Fax: 03.21.60.80.00

[Signature]
Signature

11 Product coding

GD10-P00-A-B-00

A: Gas calibration (a selection of most used variants)	
03DG	Ethylene, C ₂ H ₄ , 100% LEL-1
09DG	Propane, C ₃ H ₈ , 100% LEL-1, 2.2%Vol
09EG	Propane, C ₃ H ₈ , 100% LEL-2, 1.7%Vol
17BH	Methane, CH₄, 3%Vol
17DG	Methane, CH ₄ , 100% LEL-1, 5.0%Vol
17EG	Methane, CH ₄ , 100% LEL-2, 4.4%Vol
18BG	Methane (Biogas), CH ₄ /CO ₂ , 100%Vol
23AN	Carbon dioxide, CO ₂ , 10000 ppm
23BH	Carbon dioxide, CO ₂ , 3%Vol
24BC	Carbon dioxide (Methane immune), CO ₂ , 5%Vol
24BG	Carbon dioxide (Methane immune), CO ₂ , 100%Vol
B: Configuration	
0**	Fixed default value
Approval	
0	None
B	CSA
C	UL – Not used anymore
X	ATEX/IECEX/INMETRO
Interface	
**H	4-20mA, source/HART®
**J	4-20mA, sink/HART®
Optional, future use	
00	Fixed default value

Example_:

GD10-P00-17DG-0XH-00:

GD10P, Methane, 0-100 %LEL CH₄ (5.0% vol.), ATEX/IECEX/INMETRO, 4-20mA source/HART®

GD10-P00 and GD10-PE0

INFRARED POINT GAS DETECTOR
OPERATING MANUAL

GD10-PE0-A-B-00 (Code for detector only. See section 12 for accessories)

A: Gas calibration (a selection of most used variants)	
03AM	Ethylene, C ₂ H ₄ , 5000 ppm
17DE	Methane, CH ₄ , 20% LEL-1
B: Configuration	
0**	Fixed default value
Approval	
0	None
B	CSA
X	ATEX/IECEX/INMETRO
Interface	
**H	4-20mA, source/HART®
**J	4-20mA, sink/HART®
Optional, future use	
00	Fixed default value

Example:

GD10-PE0-17DE-0XH-00:

GD10PE, Methane, CH₄, 20 %LEL-1, ATEX/IEC Ex/INMETRO, 4-20mA, source/HART®

11.1 GD10P Gas and range code

For the most part of gases, we are using the data from INRS 2015.

F1	Product Name	Formula	%vol equivalent to 100% LEL
02DG	Acetylene	C ₂ H ₂	2.5
03DG	Ethylene	C ₂ H ₄	2.7
05DG	Ethanol	C ₂ H ₅ OH	3.3
05EG	Ethanol	C ₂ H ₅ OH	3.1
07DG	Propene	C ₃ H ₆	2.0
08DG	Acetone	C ₃ H ₆ O	2.6
09DG	Propane	C ₃ H ₈	2.2
09EG	Propane	C ₃ H ₈	1.7
11DG	Pentane	C ₅ H ₁₂	1.4
12DG	n-Hexane	C ₆ H ₁₄	1.1
13DG	Benzene	C ₆ H ₆	1.2
14DG	Toluene	C ₇ H ₈	1.2
15DG	Styrene	C ₈ H ₈	1.1
17DG	Methane	CH ₄	5.0
17EG	Methane	CH ₄	4.4
19DG	Methanol	CH ₃ OH	6.7
38DG	n-Butane	C ₄ H ₁₀	1.7
50DG	White Spirit D40		1.0
56DG	Ethane	C ₂ H ₆	2.4
73DG	Cyclohexane	C ₆ H ₁₂	1.3
79DG	Ethylene (low interference C ₂ H ₆)	C ₂ H ₄	2.7
86EG	Ethylene	C ₂ H ₄	2.4

GD10-P00 and GD10-PE0

INFRARED POINT GAS DETECTOR
OPERATING MANUAL

Accessories and spare parts

12.1 GD10P Accessories

Accessories	Description	Part Number
	GD10P Sample Flow Housing: Airtight chamber for sampling systems. Also used for calibration test.	499-810874 ❶
	GD10P Gas Test Socket: Non airtight chamber used for calibration test.	599-818154 ❷
	Duct Flange Tube Kit GD10P	499-811938 ❶
	Mosquito Set Assy GD10P: Insect protection in stainless steel mesh. Slides on the outside of the standard weather protection.	499-813397 ❷
	Sun shade Assy GD10P for horizontal mounting: protects from direct sunlight or snow fall.	499-815712 ❶
	Sun shade GD10P for pipe mounting (horizontal or vertical pipe): protects from direct sunlight or snow fall. To be used with pipe mounting plate P/N 499-816867.	599-816841 ❶
	GD10P Pipe mounting plate. U-bolts are included.	499-816867 ❶



❶ Sensitivity and response time are of the detector are not modified.

❷ Sensitivity of the detector is not modified. Response time can increase.

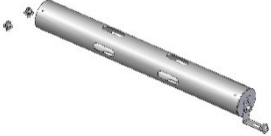
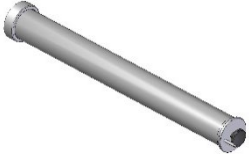
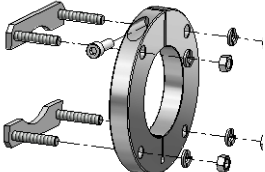
12.2 GD10PE Accessories

Accessories	Description	Part Number
	GD10PE Weather Protection/Stand Alone Kit	499-815430 ②
	GD10PE Sample Flow Housing	499-815733 ①
	GD10PE Duct Mounting Flange	499-815271 ①

12.3 Spares

Spare Parts	Description	Part Number
	Weather Protection Kit GD10P	499-810913 ②③
	Cap, cover for the gas test nozzle GD10P and GD10PE.	599-904176 ①
	Rear cover kit, composite	499-816584 ①

- ① Sensitivity and response time are of the detector are not modified.
- ② Sensitivity of the detector is not modified. Response time can increase.
- ③ This accessory is included in the EN60079-29-1 performance certificate.

12.3.1.1 Storage conditions of accessories and spare parts:

Ref	Temperature	Humidity	Pressure	Duration
499-810874		100% RH (uncondensed)	1013 hPa +/- 10%	2 years in clean atmosphere
599-818154		100% RH (uncondensed)	1013 hPa +/- 10%	2 years in clean atmosphere
499-811938		100% RH (uncondensed)	1013 hPa +/- 10%	2 years in clean atmosphere
499-813397		100% RH (uncondensed)	1013 hPa +/- 10%	2 years in clean atmosphere
499-815712		100% RH (uncondensed)	1013 hPa +/- 10%	2 years in clean atmosphere
599-816841		100% RH (uncondensed)	1013 hPa +/- 10%	2 years in clean atmosphere
499-816867	Same as detector	100% RH (uncondensed)	1013 hPa +/- 10%	2 years in clean atmosphere
499-815430		100% RH (uncondensed)	1013 hPa +/- 10%	2 years in clean atmosphere
499-815733		100% RH (uncondensed)	1013 hPa +/- 10%	2 years in clean atmosphere
499-815271		100% RH (uncondensed)	1013 hPa +/- 10%	2 years in clean atmosphere
499-810913		100% RH (uncondensed)	1013 hPa +/- 10%	2 years in clean atmosphere
599-904176		100% RH (uncondensed)	1013 hPa +/- 10%	2 years in clean atmosphere
499-816584		100% RH (uncondensed)	1013 hPa +/- 10%	2 years in clean atmosphere

GD10-P00 and GD10-PE0

INFRARED POINT GAS DETECTOR
OPERATING MANUAL

GD10-P00 and GD10-PE0

INFRARED POINT GAS DETECTOR
OPERATING MANUAL



TELEDYNE
OLDHAM SIMTRONICS
Everywhereyoulook™



AMERICAS

14880 Skinner Rd
CYPRESS
TX 77429,
USA
Tel.: +1-713-559-9200

EMEA

Rue Orfila
Z.I. Est – CS 20417
62027 ARRAS Cedex,
FRANCE
Tel.: +33 (0)3 21 60 80 80

ASIA PACIFIC

Room 2722,
No. 51 Jinzang Road,
SHANGHAI Free Trade
Zone, CHINA
Tel.: +86-134-8229-5057

www.teledynegasandflamedetection.com



© 2020 Teledyne Oldham Simtronics. All right reserved.

850-811250 Revision 13b. / June 2021