



**Searchpoint Optima Plus
with optional HART® output**



Revision History

Revision	Comment	Date
Issue 6	A04544	May 2015
Issue 7	A05004	July 2017

1. Safety Warnings and Information

WARNINGS

1. Installation must be in accordance with the recognized standards of the appropriate authority in the country concerned. For Europe see EN60079-14, EN60079-29-2, and EN61241-14. For installations in North America, the National Electrical Code (NFPA 70) should be strictly observed. Elsewhere the appropriate local or national regulations should be used.
2. Searchpoint Optima Plus is designed for installation and use in Zone 1 or 2 hazardous areas (International) and for Class 1 Division 1 or 2 area applications (North America).
3. Do not modify or alter the construction of the product as essential safety and certification requirements may be invalidated.
4. In order to maintain electrical safety, the product must not be operated in atmospheres with more than 21% oxygen.

Cautions

During usage, as some test gases may be hazardous, outlets from gassing accessories should exhaust to a safe area.

Use of the Searchpoint Optima Plus outside of the specified range of operating conditions will invalidate certification and product approval.

CSA performance approval only covers the gas detection function.

Special Conditions of Use

In order to comply with the ATEX Certification, the following special conditions of use must be adhered to: -

1. The integral supply cables must be mechanically protected and terminated in a suitable terminal or junction facility.
2. The cover fixing screws shall be stainless steel grade A4-80 minimum (only use Honeywell supplied screws).

Contents

Section	Page
1. <u>SAFETY WARNINGS AND INFORMATION</u>	2
1.1 <u>HOW TO USE THIS MANUAL</u>	7
1.2 <u>BATTERIES</u>	8
1.3 <u>DISPOSAL</u>	8
1.3.1 Searchpoint Optima Plus	8
1.3.2 Packaging	8
1.4 <u>INFORMATION</u>	9
2 <u>INTRODUCTION</u>	9
2.1 <u>SEARCHPOINT OPTIMA PLUS</u>	10
2.2 <u>SEARCHPOINT OPTIMA PLUS OPTIONS</u>	11
2.3 <u>TERMINATION UNIT OPTIONS</u>	12
2.4 <u>COMMISSIONING AND MAINTENANCE TOOLS</u>	13
2.5 <u>WEATHER PROTECTION ACCESSORIES</u>	13
2.6 <u>GASSING ACCESSORIES</u>	14
2.7 <u>MOUNTING ACCESSORIES</u>	15
3 <u>MECHANICAL INSTALLATION</u>	17
3.1 <u>SITING</u>	17
3.2 <u>INSTALLATION</u>	17
3.2.1 Standard Installation	18
3.2.2 Installation with a flow housing (sampling system)	19
3.2.3 Sampling system using Remote Gassing Cell (RGC)	20
3.2.4 Installation in a duct	20
3.2.5 Installation of gassing pipes for Remote Gassing Cell	23
4 <u>ELECTRICAL INSTALLATION</u>	24
4.1 <u>POWER SUPPLY</u>	24
4.2 <u>CABLING RECOMMENDATIONS</u>	25
4.3 <u>EARTH REGIMES</u>	25
4.4 <u>CONNECTIONS</u>	27
5 <u>OPERATION</u>	29
5.1 <u>DEFAULT CONFIGURATION</u>	29
5.2 <u>HART® OPERATION DURING FAULT</u>	29
6 <u>COMMISSIONING</u>	30
6.1 <u>FIRST TIME SWITCH ON</u>	30
7 <u>MAINTENANCE</u>	31
7.1 <u>INTRODUCTION</u>	31
7.2 <u>INSPECTION</u>	31
7.3 <u>INSPECTION OF A UNIT FITTED WITH A FLOW HOUSING</u>	31
7.4 <u>BUMP TEST (GAS CHALLENGE)</u>	32
7.5 <u>BUMP TEST (GAS CHALLENGE) WITH REMOTE GASSING CELL (RGC)</u>	33

Contents

8	<u>USE OF THE SHC1 HANDHELD INTERROGATOR</u>	34
8.1	<u>INTRODUCTION</u>	34
8.2	<u>SHC1 CONNECTION</u>	34
8.3	<u>SHC1 OPERATION</u>	36
8.4	<u>STATUS INDICATION</u>	37
8.5	<u>SHC1 BATTERY REPLACEMENT</u>	37
9	<u>COMMISSIONING USING SHC1 HANDHELD INTERROGATOR</u>	38
9.1	<u>INTRODUCTION</u>	38
9.2	<u>FIRST TIME SWITCH ON</u>	38
9.3	<u>CLEAR FAULTS OR WARNINGS</u>	39
9.4	<u>FIX THE 4-20 MA OUTPUT</u>	39
9.5	<u>TEST 4-20 MA LOOP INTEGRITY</u>	40
10	<u>MAINTENANCE USING SHC1 HANDHELD INTERROGATOR</u>	41
10.1	<u>INTRODUCTION</u>	41
10.2	<u>INSPECTION</u>	41
10.3	<u>INSPECTION OF A UNIT FITTED WITH A FLOW HOUSING</u>	42
10.4	<u>BUMP TEST (GAS CHALLENGE)</u>	43
10.5	<u>BUMP TEST (GAS CHALLENGE) WITH REMOTE GASSING CELL (RGC)</u>	43
10.6	<u>RE-ZERO SEARCHPOINT OPTIMA PLUS</u>	44
10.7	<u>CALIBRATION</u>	45
10.8	<u>INVESTIGATION OF FAULTS OR WARNINGS</u>	46
11	<u>USE OF THE HART® COMMUNICATIONS</u>	47
11.1	<u>GENERAL</u>	47
11.2	<u>CONNECTION</u>	47
11.3	<u>SEARCHPOINT OPTIMA PLUS USER INTERFACE</u>	47
11.3.1	Access Levels and Password Protection	47
11.3.2	Menu Structure	48
11.3.3	Menu Navigation	50
11.3.4	Error Reporting	50
12	<u>COMMISSIONING USING HART® COMMUNICATIONS</u>	51
12.1	<u>INTRODUCTION</u>	51
12.2	<u>FIRST TIME SWITCH ON</u>	52
12.3	<u>USER CONFIGURATION</u>	52
12.3.1	Change the Password	52
12.3.2	Configure HART® Operation during Fault	53
12.3.3	Set the Time and Date	53
12.3.4	Configure Warning, Inhibit and Overrange Signal Levels	54
12.4	<u>CONFIGURE DEVICE IDENTIFICATION INFORMATION</u>	54
12.5	<u>FIX THE 4-20 MA OUTPUT</u>	55
12.6	<u>TEST 4-20 MA LOOP INTEGRITY</u>	56
12.7	<u>CALIBRATE THE 4-20 MA LOOP</u>	56
12.8	<u>CONFIGURE INTERNAL ALARM THRESHOLD</u>	57
12.9	<u>SIMULATION</u>	57
12.10	<u>CLEAR FAULTS OR WARNINGS</u>	58

Contents

13	<u>MAINTENANCE USING HART® COMMUNICATIONS</u>	60
13.1	<u>INTRODUCTION</u>	60
13.2	<u>INSPECTION</u>	60
13.3	<u>INSPECTION OF A UNIT FITTED WITH A FLOW HOUSING</u>	61
13.4	<u>BUMP TEST (GAS CHALLENGE)</u>	62
13.5	<u>BUMP TEST (GAS CHALLENGE) WITH REMOTE GASSING CELL (RGC)</u>	63
13.6	<u>RE-ZERO SEARCHPOINT OPTIMA PLUS</u>	64
13.7	<u>CALIBRATION</u>	64
13.8	<u>STORE CALIBRATION INFORMATION</u>	65
13.9	<u>INVESTIGATION OF FAULTS OR WARNINGS</u>	66
14	<u>PROBLEM SOLVING</u>	67
14.1	<u>TROUBLESHOOTING</u>	67
14.2	<u>WARNING AND FAULT MESSAGES</u>	71
14.3	<u>FURTHER ASSISTANCE</u>	72
15	<u>SPECIFICATIONS</u>	73
15.1	<u>SPECIFICATIONS</u>	73
15.2	<u>AVAILABLE GAS CALIBRATIONS</u>	74
15.2.1	Hydrocarbon version of Searchpoint Optima Plus	74
15.2.2	Ethylene version of Searchpoint Optima Plus	77
15.3	<u>CROSS INTERFERENCE TO OTHER GASES AND VAPOURS</u>	78
16	<u>ORDERING INFORMATION</u>	79
17	<u>WARRANTY SUMMARY</u>	82
18	<u>CERTIFICATION AND APPROVALS</u>	83
18.1	<u>EC DECLARATION OF CONFORMITY</u>	83
18.2	<u>HAZARDOUS AREA CERTIFICATION</u>	83
18.2.1	ATEX	83
18.2.2	UL	83
18.2.3	InMetro (Brazil)	83
18.2.4	CSA	84
18.2.5	FM	84
18.2.6	CU-TR Ex (Eurasian) Approval – XTC Version	84
18.2.7	CCCF (China)	84
18.2.8	IECEX	84
18.3	<u>PERFORMANCE APPROVALS</u>	84
18.3.1	ATEX	84
18.3.2	FM	85
18.3.3	Russian Pattern Approval (Metrology) - XTC Version	85
18.4	<u>MARINE APPROVALS</u>	86
18.5	<u>SHC1 HANDHELD INTERROGATOR HAZARDOUS AREA CERTIFICATION</u>	86
18.5.1	ATEX	86
18.5.2	IECEX	86
19	<u>APPENDIX 1 – SHC1 ADDITIONAL FUNCTIONS</u>	87
19.1	<u>CHANGING THE TARGET GAS</u>	87
19.2	<u>SELF TEST</u>	88

Contents

20	<u>APPENDIX 2 – HART® ADDITIONAL FUNCTIONS</u>	89
	20.1 <u>CHANGING THE TARGET GAS</u>	89
	20.2 <u>SET HART® LOOP CURRENT MODE</u>	91
21	<u>APPENDIX 3 – SPECIAL NOTES FOR HONEYWELL MC TOOLKIT USERS</u>	92
22	<u>APPENDIX 4 – END OF LIFE BATTERY REMOVAL</u>	93
23	<u>APPENDIX 5 - HART® COMMANDS USED</u>	94
	23.1 <u>UNIVERSAL COMMANDS</u>	94
	23.2 <u>COMMON-PRACTICE COMMANDS</u>	94
	23.2.1 Supported Commands	94
	23.2.2 Burst Mode	94
	23.2.3 Catch Device Variable	94
	23.3 <u>DEVICE-SPECIFIC COMMANDS</u>	95

1. Safety Warnings and Information

1.1 How to use this manual

This manual contains three sets of instructions for Searchpoint Optima Plus - as a stand alone unit, when using the SHC1 Handheld Interrogator and when using the HART® communications. Use the guide below to find the relevant chapters: -

Stand alone unit

Chapters 1-5	Introduction, Installation and Operation
Chapters 6-7	Commissioning and Maintenance
Chapters 14-16	Problem Solving, Specification and Certification

With SHC1 Handheld Interrogator

Chapters 1-5	Introduction, Installation and Operation
Chapters 8-10	Use of SHC1, Commissioning and Maintenance
Chapters 14-16	Problem Solving, Specification and Certification
Appendix 1	Additional Functions

With HART® communications

Chapters 1-5	Introduction, Installation and Operation
Chapters 11-13	Use of HART®, Commissioning and Maintenance
Chapters 14-16	Problem Solving, Specification and Certification
Appendix 2	Additional Functions

Searchpoint Optima Plus with XNX Universal Transmitter

When using Searchpoint Optima Plus with the XNX Universal Transmitter, this manual and the XNX Universal Transmitter manual are required. The relevant chapters of this manual are: -

Chapters 1-4	Introduction and Installation
Chapter 7	Maintenance
Chapters 14-16	Problem Solving, Specification and Certification

For Commissioning and Operation please use the XNX Universal Transmitter manual (part number 1998M0738).

The XNX Universal Transmitter has its own integral HART® communications and will not re-transmit the Searchpoint Optima Plus communications. Please refer to the XNX Universal Transmitter manual for the appropriate HART® commands and menu structure.

Note: This manual is for use with Searchpoint Optima Plus units of mod state 9 and above.

Note: Translations of this manual in various languages are available, either on the CD accompanying the product or at our website. Navigate to www.honeywellanalytics.com and use the Document Download utility. It may be necessary to register to view all of the available documents.

1. Safety Warnings and Information

1.2 Batteries

Below is a listing of batteries present in the products covered by this manual:

Battery Description	Battery Type	Location	Replaceable
Size 6LR61 (PP3)	Alkaline	SHC1 Handheld Interrogator	Yes
Size CR2032	Lithium Manganese Dioxide	Searchpoint Optima Plus	No

Batteries contain various active ingredients which store electrochemical energy and can be dangerous if they contact your skin.



Removal and Disposal Information:

The product documentation includes instructional information of the proper removal of the batteries used in these products (Section 8.5 and Appendix 4). The symbol left means that according to local laws and regulations the battery installed within your product should be disposed of separately from household waste. When the battery reaches its end of life, take it to a collection point designated by local authorities.

1.3 Disposal

1.3.1 Searchpoint Optima Plus

When Searchpoint Optima Plus reaches the end of its life it should be disposed of in accordance with local regulations.

Searchpoint Optima Plus consists of the following types of materials: -

- Stainless steel
- Various epoxy resins
- Various glasses
- Various engineering plastics
- Various rubbers
- Printed circuit boards

See Appendix 4 for instructions on battery removal.

1.3.2 Packaging

Searchpoint Optima Plus packaging is made from cardboard. Facilities for recycling are widely available.

1. Safety Warnings and Information

1.4 Information

This manual is for use with Searchpoint Optima Plus, Searchpoint Optima Plus XTC, Searchpoint Optima X and Searchpoint Optima Z units of mod state 9 and above. For Searchpoint Optima X and Searchpoint Optima Z please also refer to the supplementary information sent with the product.

Honeywell Analytics can take no responsibility for installation and/or use of its equipment if not done in accordance with the appropriate issue and/or amendment of the Operating Manual.

The reader of this Operating Manual should ensure that it is appropriate in all details for the exact equipment to be installed and/or operated. If in doubt, contact Honeywell Analytics for advice.

The following types of notices are used throughout this Operating Manual:

WARNING

Identifies a hazardous or unsafe practice which could result in severe injury or death to personnel.

Caution: Identifies a hazardous or unsafe practice which could result in minor injury to personnel, or product or property damage.

Note: Identifies useful/additional information.

Every effort has been made to ensure the accuracy of this document, however, Honeywell Analytics can assume no responsibility for any errors or omissions in this document or their consequences.

Honeywell Analytics would greatly appreciate being informed of any errors or omissions that may be found in the content of this document.

For information not covered in this document, or if there is a requirement to send comments/corrections about this document, please contact Honeywell Analytics using the contact details given on the back page.

Honeywell Analytics reserve the right to change or revise the information supplied in this document without notice and without obligation to notify any person or organization of such revision or change. If information is required that does not appear in this document, contact the local distributor/agent or Honeywell Analytics.

2. Introduction

2.1 Searchpoint Optima Plus

Searchpoint Optima Plus is an infrared hydrocarbon gas detector suitable for use in hazardous areas. It has worldwide certification approvals including IECEx, ATEX, UL and CSA.

It uses the principle of infrared absorption to detect hydrocarbon gases and vapours in various concentration ranges.

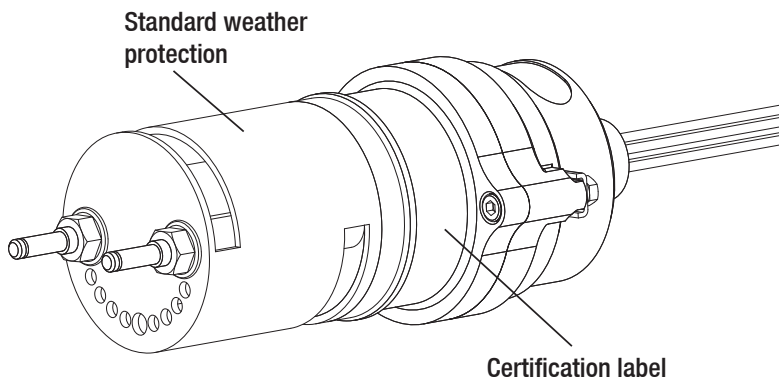

Searchpoint Optima Plus has a robust stainless steel enclosure with an ingress protection level of IP66 and IP67. Depending on the certification option, it has an M25 or 3/4 NPT mounting thread.

Searchpoint Optima Plus has a 4-20 mA signal output that corresponds to 0-100 %FSD. Output values below 4 mA indicate fault, warning and inhibit.

Searchpoint Optima Plus is supplied calibrated and linearised for a specific target gas. A wide selection of gases is available in 0 – 100 %LEL range, as well as some ppm range options. The range 0 – 100 %v/v methane is available exclusively for use in sampling systems.

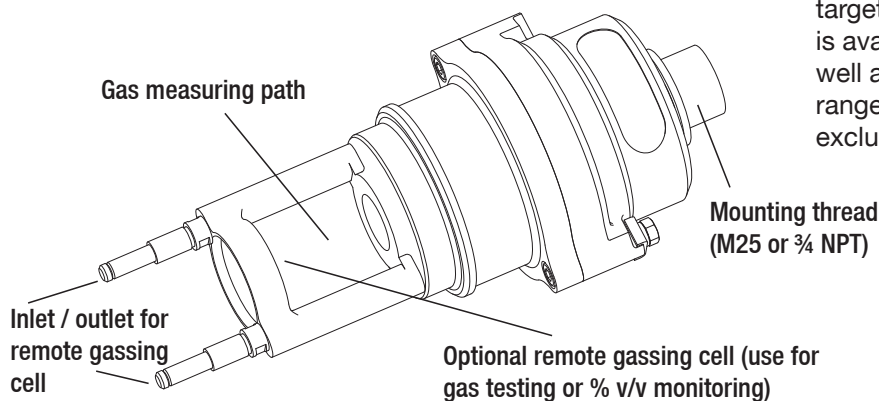

Searchpoint Optima Plus can communicate with the SHC1 Handheld Interrogator, which can be used to access comprehensive diagnostic information, and to carry out calibration and configuration. As an option, HART® communications are available to perform the same functions either using a HART® handheld device or from a central control room.

Note: Searchpoint Optima Plus can be installed, commissioned and functionally tested using only the 4-20 mA output. However, configuration, calibration and fault diagnosis require either the SHC1 Handheld Interrogator, HART® communications or the XNX Universal Transmitter.

2. Introduction

2.2 Searchpoint Optima Plus Options

Searchpoint Optima Plus is available in an ethylene version which is optimised for the detection of certain solvents.

Searchpoint Optima X is a variant of Searchpoint Optima Plus exclusively for use in sampling systems. A fast speed of response is made possible by minimising the volume of the sample cell. Please contact Honeywell Analytics for further details of this variant.

Searchpoint Optima Z is a variant of Searchpoint Optima Plus optimised for the detection of the solvents ethanol and ethyl acetate. It is exclusively for use in sampling systems. Please contact Honeywell Analytics for further details of this variant.

All versions of Searchpoint Optima Plus can be supplied with HART® over 4-20 mA communications.

2. Introduction

2.3 Termination unit options

There are several termination unit options for Searchpoint Optima Plus, depending on the certification required, whether digital communications will be used and additional features such as a local display.

HALO Junction Box*

- ATEX, IECEx approvals
- Ex e enclosure
- One M25 and three M20 cable entries
- Visual status indication (Normal, Warning, Fault, Alarm, Inhibit)
- Non-intrusive connection for HART® handheld device (optional)



XNX Universal Transmitter

- ATEX, IECEx, UL, CSA approvals
- Five ¾ NPT or M25 cable entries
- Local display
- Non-intrusive access using magnetic switches
- HART® communications
- Non-intrusive connection for HART® handheld device (optional)
- Modbus communications (optional)
- Relays (optional)



DVC 100 Series Termination Unit

- ATEX, IECEx approvals
- Ex e enclosure
- One M25 and two M20 cable entries
- Non-intrusive connection for SHC1 Handheld Interrogator
- Modbus communications (optional)



Honeywell Analytics Junction Box

- ATEX, IECEx approvals
- Ex e enclosure
- One M25 and three M20 cable entries
- SHC1 Handheld Interrogator connection using SHC Protection Device (intrusive)

UL/CSA Aluminium Junction Box

- UL, CSA approvals
- Two ¾ NPT cable entries
- SHC1 Handheld Interrogator connection using SHC Protection Device (intrusive)

* Contact Honeywell Analytics for availability

2. Introduction

2.4 Commissioning and Maintenance Tools

SHC1 Handheld Interrogator

The SHC1 Handheld Interrogator is a commissioning and maintenance tool which communicates with Searchpoint Optima Plus. It can be connected directly to a DVC100 series termination unit (non-intrusive), or used with other types of junction box provided the SHC Protection Device is used (hot work permit required).

- Use for configuration, commissioning, test and maintenance
- Portable
- Intrinsically safe
- Dedicated communication device for Honeywell Analytics optical detectors

HART® communication option

Searchpoint Optima Plus can be supplied with HART® over 4-20 mA communication.

- Use for configuration, commissioning, test and maintenance
- Communicates with local HART® handheld device or remote HART® host
- Conforms to version 7 of the HART® protocol

2.5 Weather protection accessories

Searchpoint Optima Plus has a range of weather protection accessories designed to protect the optical surfaces from environmental conditions without compromising performance. Please contact Honeywell Analytics to discuss the most suitable weather protection for a particular application.

As standard, Searchpoint Optima Plus is supplied with Standard Weather Protection, Dust Barrier and Sunshade / Deluge Protection.

Standard Weather Protection (2108B0276)

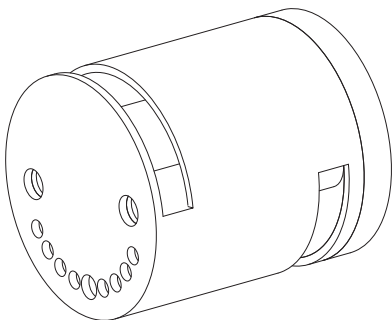

Provides the best compromise between response time and protection. Suitable for indoor, outdoor and duct mounting applications

Sunshade/Deluge Protection (2108D0275)

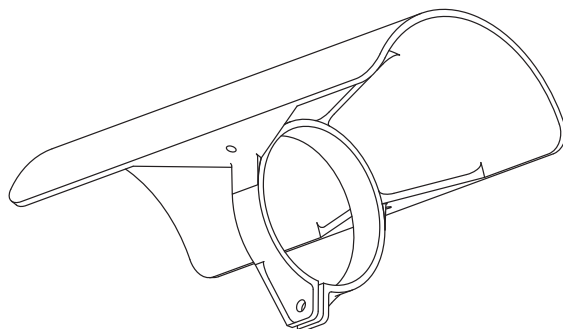

Provides additional protection against heavy rainfall, wash downs and direct sunlight.

2. Introduction

Storm Baffle (2108B0280)

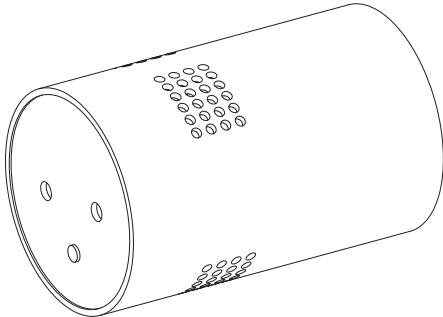

Provides increased protection against torrential rain and driven sea-spray. Recommended for exposed installations in maritime locations or areas where monsoon or tropical rain conditions are experienced. Also provides protection against steam and can be used in unfiltered ducts.

This accessory will increase the detector's response time.

Dust Barrier (2108B0259)

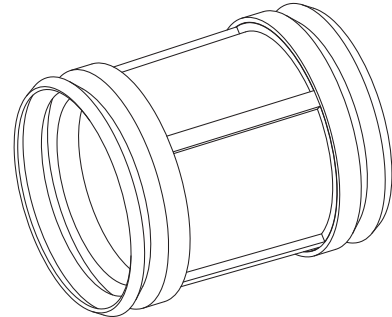

Prevents the ingress of dust or oil mist and protects the optics in very wet or exposed locations. Fits under the Standard Weather Protection.

This accessory will increase the detector's response time.

2.6 Gassing Accessories

Searchpoint Optima Plus has a range of accessories designed to assist with gas testing.

Calibration Cap (2108B0272)

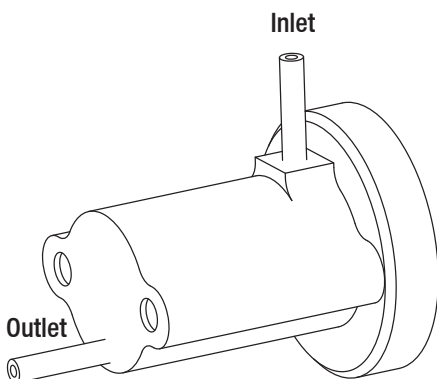

Used to achieve accurate calibration of Searchpoint Optima Plus. Requires all weather protection to be removed except dust barrier.

Gassing Cover (2108D0258)

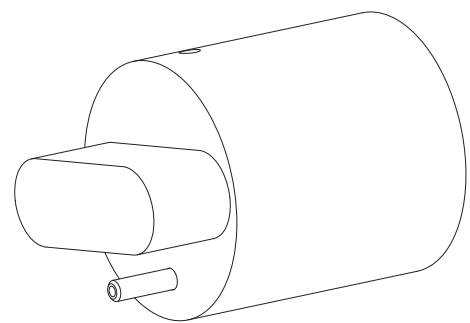

Used to apply gas to Searchpoint Optima Plus in the field. Suitable for functional checking. Fits over the standard weather protection. (For calibration, use the Calibration Cap).

Caution: The Calibration Cap and the Gassing Cover must be removed after use.

2. Introduction

Flow Housing (2108B0282)

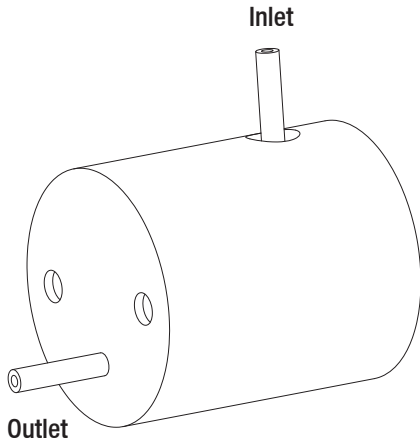

For use in sampling system applications. Material: solvent resistant anodised aluminium, with stainless steel nozzles, outside diameter 6 mm. Searchpoint Optima Z is only supplied with a flow housing.

Remote Gassing Cell (2108B0240)

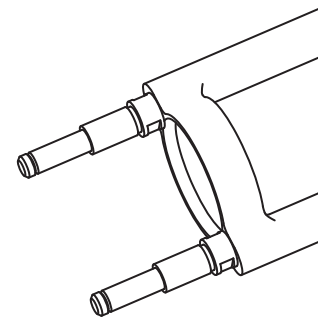

Enables high %v/v concentration gas to be applied remotely for performing bump tests. Useful for units installed in ducts or inaccessible areas. Required for 0 – 100 %v/v methane range (sampling system only). Searchpoint Optima X has a special version of the RGC.

The RGC is a factory fitted option.

2.7 Mounting Accessories

Junction Box Adaptor Plate (04200-A-1040)

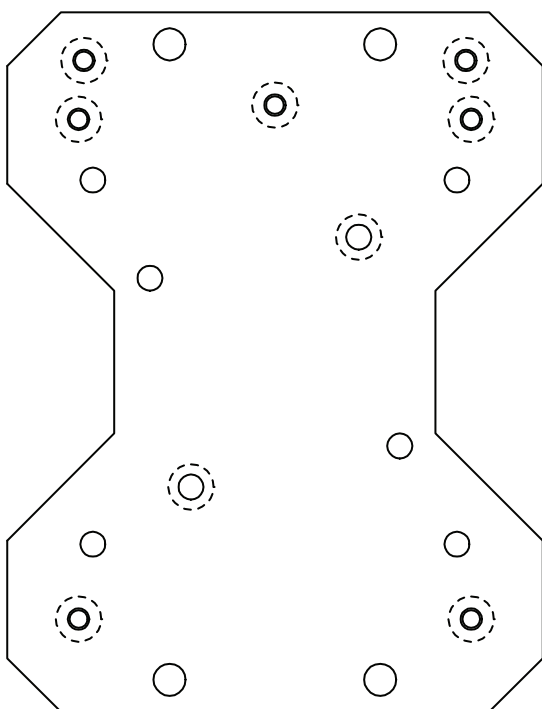

The Junction Box Adaptor Plate enables low gland clearance junction boxes to be used without the Searchpoint Optima Plus fouling on the wall / mounting surface, for example the Honeywell Analytics Junction Box (00780-A-0100). It also has mounting points for the DVC100 and DVC100 MK2 termination units.

2. Introduction

European Duct Mounting Kit – Metric Threads (2104B0349)

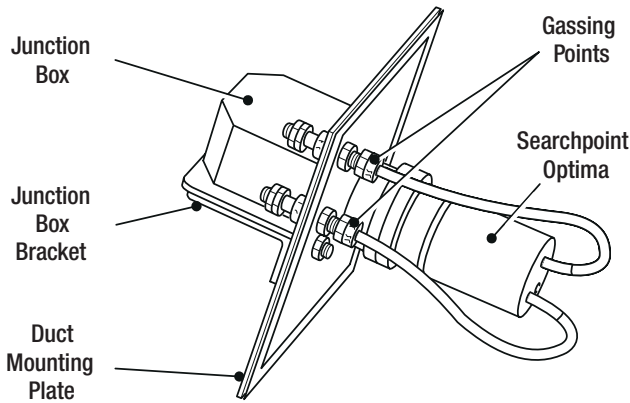

This kit enables M25 versions of Searchpoint Optima Plus to be conveniently mounted inside a duct. Electrical connections are made to the detector via a junction box which is mounted outside of the duct. Test gas can be applied to the detector via the gassing points provided.

Note: the detector must have the Remote Gassing Cell option factory fitted.

US Duct Mounting Kit – NPT Threads (2442-0016)

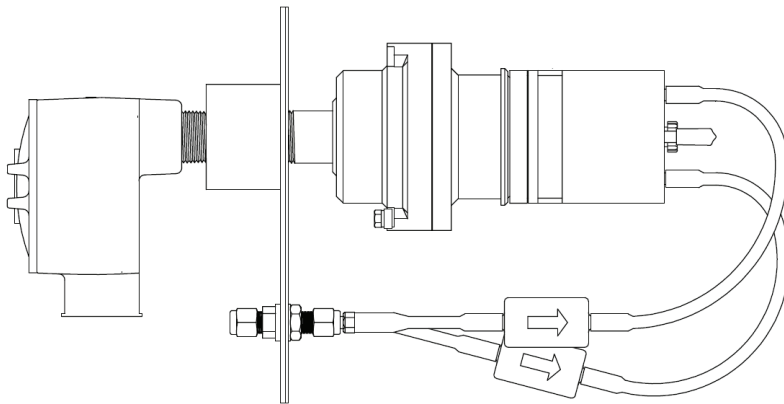

This kit enables 3/4 NPT versions of Searchpoint Optima Plus to be conveniently mounted inside a duct. Electrical connections are made to the detector via a junction box which is mounted outside of the duct. Test gas can be applied to the detector via the gassing points provided.

Note: the detector must have the Remote Gassing Cell option factory fitted.

3. Mechanical Installation

WARNING

Installation must be in accordance with the recognized standards of the appropriate authority in the country concerned. For Europe see EN60079-14, EN60079-29-2, and EN61241-14. For installations in North America, the National Electrical Code (NFPA 70) should be strictly observed. Elsewhere the appropriate local or national regulations should be used.

3.1 Siting

The placement of gas detectors should be determined following the advice of experts having specialist knowledge of gas dispersion, experts having knowledge of the process plant system and equipment involved, safety personnel and engineering personnel. The agreement reached on the location of detectors should be recorded.

Guidance on the positioning of gas detectors to provide the best detection coverage is contained in IEC/EN 60079-29-2 and other national Codes of Practice. It is recommended that the installation designer consults these Codes of Practice when determining where detectors are to be located.

In addition, consider the following points: -

1. Searchpoint Optima Plus must be mounted horizontally to reduce the risk of contamination building up on the optical surfaces.
2. Searchpoint Optima Plus is certified and specified for operation in ambient temperatures from -40°C to +65°C. Operation of the unit outside of this temperature range invalidates the certification and the warranty.
3. Searchpoint Optima Plus is specified for operation in environments where the rate of change of unit temperature is less than 3°C / minute. Exceeding this rate of change of temperature will cause the unit to report a fault and may cause permanent damage.
4. Searchpoint Optima Plus has been vibration tested to the levels specified in EN60079-29-1. Do not install units in locations where the vibration exceeds this level.
5. Where possible, locate detectors away from sources of airborne contaminants and steam / condensation, which could build up on the optical surfaces.
6. In extreme environmental conditions, consider the use of additional weather protection options (see Introduction, Weather Protection Accessories).

Please contact Honeywell Analytics for further advice if required.

3.2 Installation

Note: Searchpoint Optima Plus must be mounted horizontally to reduce the risk of contamination building up on the optical surfaces.

The Standard Installation section describes general mounting and installation. Additional information is provided for using Searchpoint Optima Plus in a sampling system or a duct, and for the use of the Remote Gassing Cell.

3. Mechanical Installation

3.2.1 Standard Installation

1. Select a suitable entry in the junction box - Searchpoint Optima Plus must be mounted horizontally. The mounting thread size is either M25 or ¾ NPT (certification dependent).
2. Secure the junction box to the mounting surface in the required orientation. Refer to individual junction box instructions for mounting information.
3. Remove the junction box lid.
4. Fit the Searchpoint Optima Plus detector to the junction box. Ensure that the junction box thread is compatible with the Searchpoint Optima Plus thread. Feed the Searchpoint Optima Plus cables through the entry and screw the detector in firmly. Be careful to avoid cross-threading.

Note: M25 versions have a nylon sealing washer which is required to maintain the IP rating.

Note: M25 versions should be secured using a locknut. See diagram below.

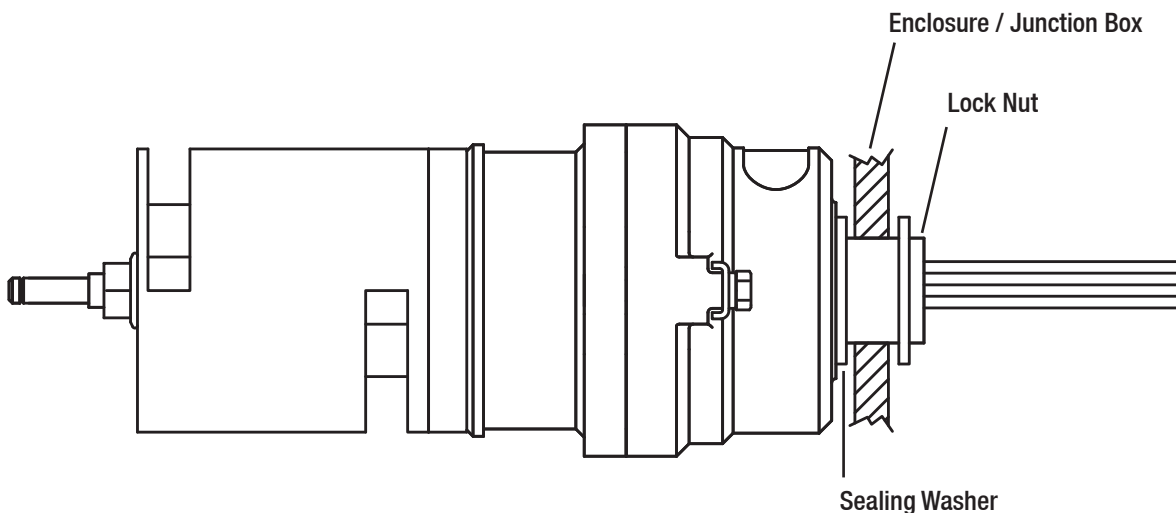

Ensure that the Standard Weather Protection is in the correct orientation, with the semi-circle of holes at the bottom as shown. If necessary, unscrew the detector a little, and / or remove the Weather Protection and rotate it through 180° to the correct orientation. For M25 versions, ensure that the nylon washer remains compressed to maintain the IP rating.

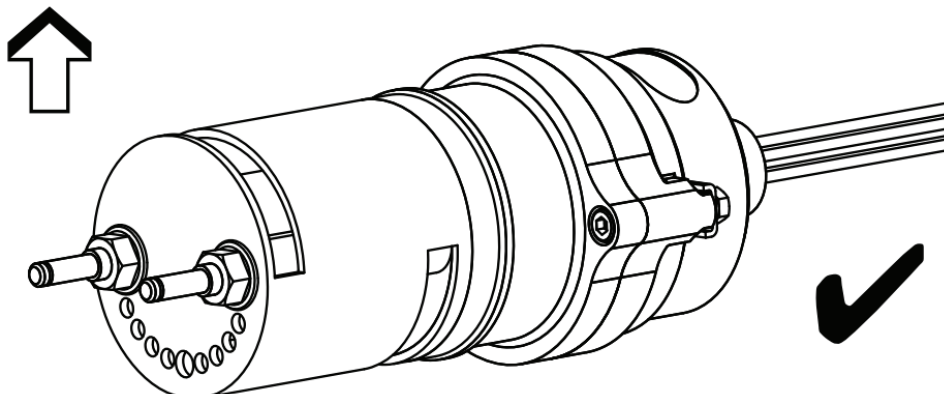

3. Mechanical Installation

5. Fit the Sunshade / Deluge protection.

The Sunshade/Deluge protection should be clamped around the base of the Standard Weather Protection with the longer overhang extending beyond the Standard Weather Protection. Ensure the clamp does not cover the gas venting slot of the Standard Weather Protection.

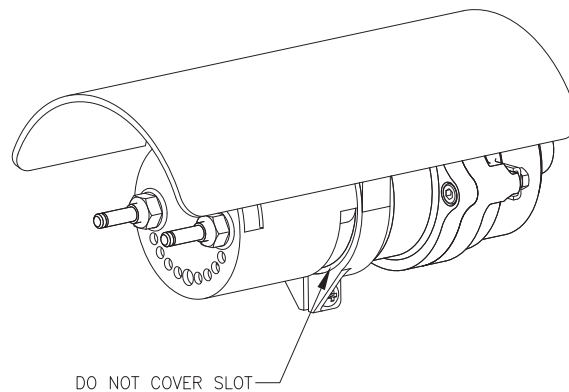

6. Fit approved cable glands to the junction box cable entries as required to maintain the certification and IP rating.
7. Fit approved blanking plugs to the unused junction box cable entries as required to maintain the certification and IP rating.
8. Fit the external field wiring through the cable glands and secure.
9. Terminate the gas detector and field wiring in accordance with Chapter 4 (Electrical Installation).
10. Replace the junction box lid.

3.2.2 Installation with a flow housing (sampling system)

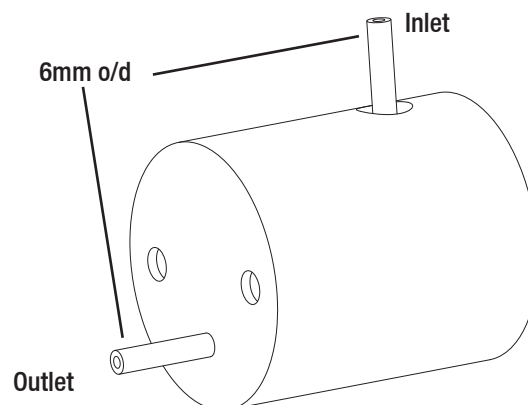

Sampling systems should be designed to comply with the Searchpoint Optima Plus operating conditions, for example, sample temperature, cleanliness, water content, dust content etc.

In addition, consider the following points: -

1. Flow rate should be between 0.7 litres per minute and 2 litres per minute.
2. A flow failure indicator should be included in the system.
3. If possible, use negative pressure to avoid the risk of pressurisation affecting the gas reading.
4. The choice of sampling lines should be appropriate to the application.

3. Mechanical Installation

3.2.3 Sampling system using Remote Gassing Cell (RGC)

The gas ranges 0 – 100 %v/v methane, 0 – 600,000 ppm propane and 0 – 400,000 ppm propane are exclusively for use with the Remote Gassing Cell (RGC) in sampling systems.

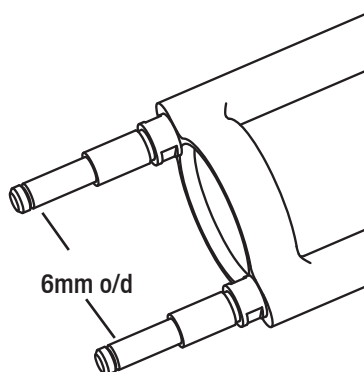

Sampling systems should be designed to comply with the Searchpoint Optima Plus operating conditions, for example, sample temperature, cleanliness, water content, dust content etc.

The RGC has inlet and outlet gassing pipes with outer diameter 6 mm. The cell is not directional so either pipe can be used as the inlet.

Note: The Searchpoint Optima Plus will often be supplied with a Flow Housing fitted. Ensure that the correct gassing pipes are used. The gassing pipes for the RGC are the ones which support the retaining nuts for the Weather Protection or the Flow Housing.

In addition, consider the following points: -

1. Maximum flow rate should be 0.3 litres per minute.
2. A flow failure indicator should be included in the system.
3. If possible, use negative pressure to avoid the risk of pressurisation affecting the gas reading.
4. The choice of sampling lines should be appropriate to the application.

3.2.4 Installation in a duct

European Duct Mounting Kit – Metric Threads

Caution: Take note of the requirements on earthing given in Chapter 4. Earth loops should be avoided.

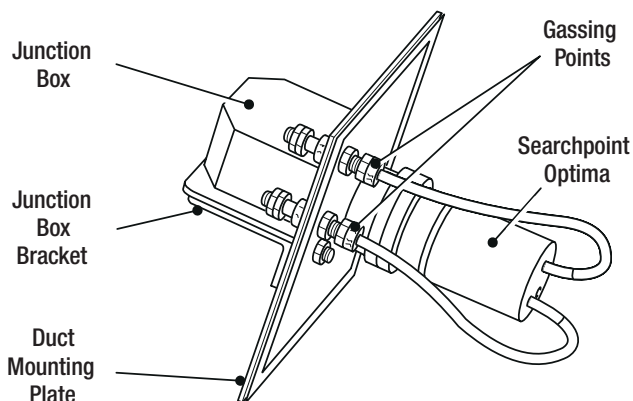

Note: In order to make use of the gassing points provided, the Searchpoint Optima Plus unit must be factory fitted with the Remote Gassing Cell (2108B0240).

3. Mechanical Installation

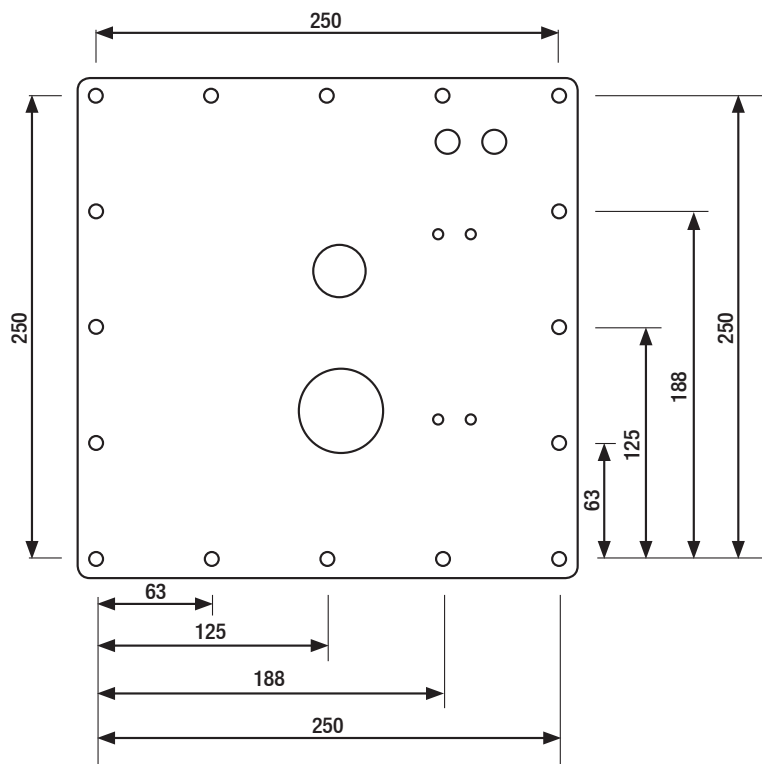

Note 1: Dimensions shown in mm.

Note 2: The cutout in the duct should be 230mm x 230mm.

The duct mounting kit is assembled and installed onto a duct as follows:-

1. Cut a square 230mm by 230mm hole in the duct wall. Drill the holes required to attach the mounting plate to the duct wall.
2. Place the Searchpoint Optima Plus unit on the side of the mounting plate where the threaded bushes protrude and feed the wires through the central hole.
3. Locate the unit's boss in the central hole and feed the unit's wires through the chosen cable entry on the junction box.
4. Screw the unit into the junction box until the assembly is secure with the mounting plate trapped between the box and the Searchpoint Optima Plus.
5. Add the appropriate support bracket and bolt to the junction box.
6. Blank off any unused support bushes.
7. Remove the covers from the ends of the gassing cell inlet tubes.
8. Attach the gassing tubing to the ends of the gassing cell inlet tubes.
9. Fasten the mounting plate to the wall of the duct, ensuring that the seal is compressed.
10. Fit approved cable glands to the junction box cable entries as required to maintain the certification and IP rating.
11. Fit approved blanking plugs to unused junction box cable entries as required to maintain the certification and IP rating.
12. Fit the external field wiring through the cable glands and secure.
13. Terminate the gas detector and field wiring in accordance with Chapter 4 (Electrical Installation).

3. Mechanical Installation

US Duct Mounting Kit – NPT Threads

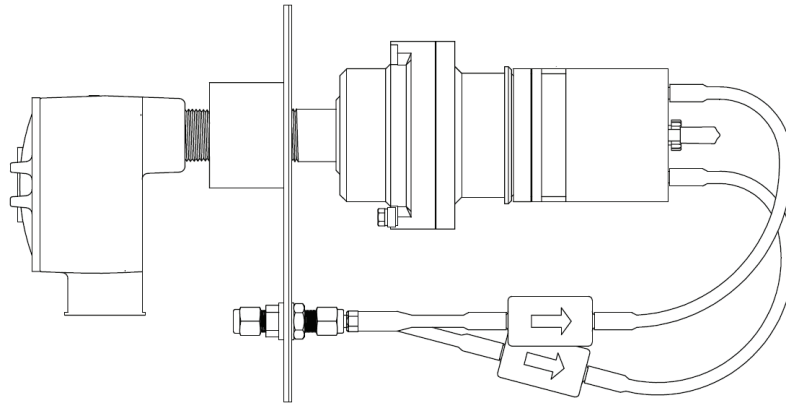

Note: In order to make use of the gassing points provided, the Searchpoint Optima Plus unit must be factory fitted with the Remote Gassing Cell (2108B0240).

Note: CSA approval only applies for duct flow rates less than 5m/s.

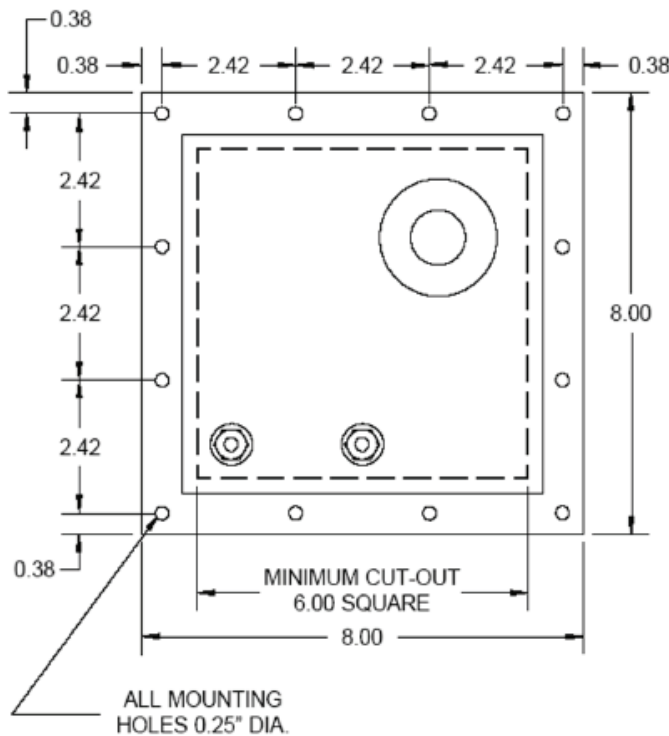

Note: Dimensions shown in inches.

The duct mounting kit is assembled and installed onto a duct as below:-

1. Cut a square 6” by 6” hole in the duct wall. Drill the holes required to attach the mounting plate to the duct wall.
2. Place the Searchpoint Optima Plus unit on the side of the mounting plate where the threaded bushes protrude and feed the wires through the central hole.
3. Locate the unit’s boss in the central hole and feed the unit’s wires through the chosen cable entry on the junction box.

3. Mechanical Installation

4. Screw the unit into the junction box until the assembly is secure with the mounting plate trapped between the box and the Searchpoint Optima Plus.
5. Remove the covers from the ends of the gassing cell inlet tubes.
6. Attach the gassing tubing to the ends of the gassing cell inlet tubes.
7. Fasten the mounting plate to the wall of the duct, ensuring that the seal is compressed.
8. Fit approved cable glands to the junction box cable entries as required to maintain the certification and IP rating.
9. Fit approved blanking plugs to unused junction box cable entries as required to maintain the certification and IP rating.
10. Fit the external field wiring through the cable glands and secure.
11. Terminate the gas detector and field wiring in accordance with Chapter 4 (Electrical Installation).

3.2.5 Installation of gassing pipes for Remote Gassing Cell

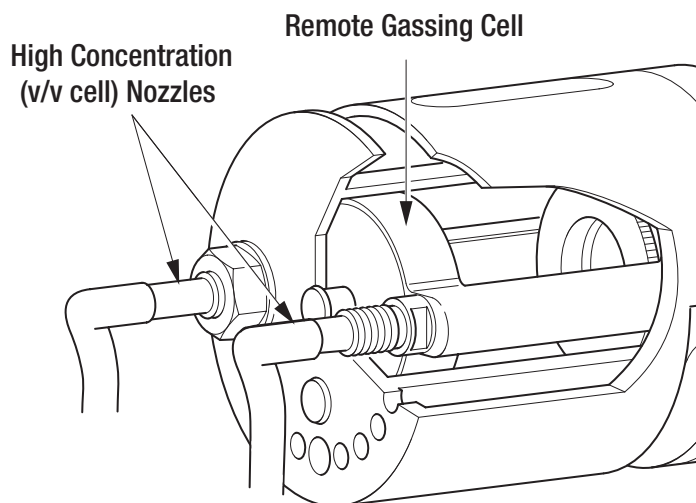

The Remote Gassing Cell (RGC) is used for functional response checking (bump testing) when the Searchpoint Optima Plus is installed in an inaccessible location. The RGC should be fitted with gassing accessories as follows: -

1. Use an inlet pipe fitted with an inline particle filter.
2. Use an exhaust pipe fitted with a one-way valve.
3. Ensure that the exhaust vents well away from the Searchpoint Optima Plus to avoid affecting the gas reading.
4. High concentration gas will be used in the RGC. Ensure that the exhaust vents safely.

4. Electrical Installation

4.1 Power supply

The Searchpoint Optima Plus requires a voltage supply from the controller of between 18 Vdc and 32 Vdc. The maximum power consumption is 5 W. The maximum loop resistance is 600 Ω. The minimum loop resistance for HART® operation is 230 Ω.

Note: In current source mode, for supply voltages of 18 to 20 Vdc the maximum loop resistance is 500 Ω. The table below gives the total power consumption for Searchpoint Optima Plus with some common junction box options.

Termination unit	Total power consumption including Searchpoint Optima Plus
HALO**	6 W
XNX	10 W
DVC100 series	6 W
Honeywell Analytics Junction Box	5 W

Ensure that a minimum supply voltage of 18 Vdc is measured at the Searchpoint Optima Plus, taking into account the voltage drop due to cable resistance.

The maximum resistance in the field cable is calculated as follows:

$$R \text{ loop} = (V \text{ controller} - V \text{ detector min}) / I \text{ detector}$$

Example:

The controller is supplying a nominal 24 Vdc (V controller), the detector minimum allowable voltage is 18 Vdc (V detector min), therefore the maximum allowable voltage drop between the controller and detector is 6Vdc; this means a voltage drop of 3 V in each core (+ve core and -ve core).

Power consumption of the detector is 5.0 W. The current required to drive the detector at the minimum voltage is ($I = P / V$), $5.0 / 18 = 278 \text{ mA}$ (I detector).

So, the maximum field cable loop resistance (R loop) = $6 / 0.278 = 22 \text{ } \Omega$, or $11 \text{ } \Omega$ per core, (allowing for component variations, losses, etc.).

The following tables show the maximum cable distances between the controller and Searchpoint Optima Plus for a 1.5 mm² (16 AWG*) core cable, for different termination unit options, assuming a voltage drop of 3 V in each core. The tables are examples only and actual cable parameters and source power supply voltage for the application should be used to calculate the maximum cable distance allowed at the installation site.

Termination unit	Total power consumption	Max Cable Length for 1.5 mm ² (16 AWG*) core (Cable resistance 12.7 Ω/km (20.4 Ω/mile))	
		Metres	Feet
HALO**	6 W	709	2326
XNX	10 W	433	1421
DVC100 series	6 W	709	2326
Honeywell Analytics Junction Box	5 W	866	2841

*nearest equivalent

Note: Sufficient operational margins should be allowed

**Contact Honeywell Analytics for availability

4. Electrical Installation

4.2 Cabling recommendations

The cable used should be appropriate for the hazardous area classification and meet local, national and company regulations. The use of industrial grade, suitably armoured field cable is recommended.

For example, three-core copper cable, with screen (90% coverage) and suitable mechanical protection (e.g. steel wire armour or conduit).

When using HART® communications, there are some additional considerations. In particular, low capacitance cable should be used. Further detailed information can be found at the HART® Communication Foundation's website www.hartcomm.org.

4.3 Earth regimes

Any earthing regime employed must avoid earth loops.

The following information is provided to assist with proper earthing of Searchpoint Optima Plus: -

- Searchpoint Optima Plus has an earth wire (green and yellow) for connection to protective earth. This is connected to the enclosure and isolated from the other wires. Maximum voltage between earth and the other wires is 500 V.
- There is an earthing point on the outside of the Searchpoint Optima Plus enclosure for connection to protective earth. Alternatively, an earth connection can be made via the mounting thread, e.g. to conduit, a metal junction box, or a continuity plate in a plastic junction box.
- Searchpoint Optima Plus does not require an instrument earth connection.

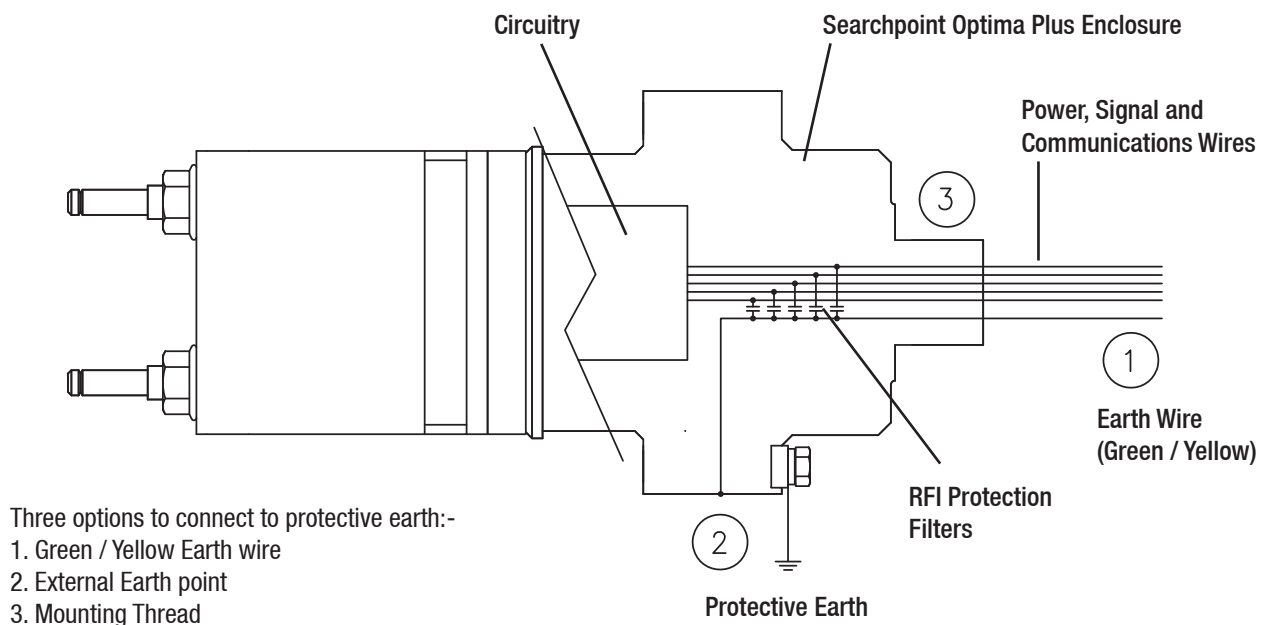

4. Electrical Installation

In addition, consider the following points: -

General recommendations

1. In general, correctly engineered star earthing arrangements minimise earth current crosstalk and noise, improving the reliability and performance of instrumentation.
2. The use of a single, screened / shielded cable for each field device ensures good screening / shielding and reduces crosstalk.
3. Low noise instrument earth should only be connected to protective earth at a single point on a site / installation. This connection should be made in such a manner that it does not introduce noise onto the instrument earth.

Field Cabling

1. The entire length of the field cabling connected to a unit should be screened / shielded. The screen / shield should be connected to a low noise instrument earth at one end.
2. The screens / shields of field cabling must not be connected in a manner that creates earth loops or that will result in the screens / shields carrying large currents from heavy plant or equipment.
3. If armoured cable is being used it is necessary to prevent the armour becoming connected to the screen / shield.
4. For installations where the field cable conductors run through conduit or armour connected to protective earth, the conduit or armour should not be considered as a sufficient screen / shield. A separate cable screen / shield, connected to a low noise instrument earth should be employed.

Maximum voltages

1. Any earthing arrangement employed should ensure that the maximum peak voltage between the unit's case earth and any field cable conductor is less than 500 V. This includes conditions where transient surge voltages are generated by lightning or the switching of heavy electrical plant. Earthing arrangements that employ multiple protective earths or earth grids significantly increase the likelihood of large transient surge voltages being generated between a unit's case earth and the field cable conductors. If it is suspected that voltages between the unit's case earth and any field cable conductor may exceed 500 V it is strongly recommended that surge suppression devices be installed close to the unit.

Note: Suitable, certified surge suppression devices include MTL's TP-48-I-NDI and Pepperl & Fuchs' FN-LB-1. Surge suppression devices should be checked regularly and replaced if necessary.

Interference and noise

1. For installations in Europe, all electrical equipment connected to the system should comply with EN50270. For non-European installations, electrical equipment connected to the system should comply with applicable national or international EMC standards.
2. Any electrical interference induced onto the conductors of a 4 – 20 mA loop by the installation must be kept below the levels necessary to comply with the requirements of EN60079-29-1 or other applicable gas detector performance requirements / standards. In practice, this means that peak noise currents induced on the current loop should be no greater than ± 0.25 mA.
3. The 0 V rail of the control card/control system is often directly connected to one side of the 4-20 mA current sensing resistor. Electrical noise on this rail is therefore directly connected to the 4-20 mA input. In order to avoid additional noise being induced on the 0 V rail, it should not be commoned with the protective earth, which frequently carries a high level of electrical noise.
4. Ideally, the 24 V supply reaching units should be free from large transients, fluctuations or high frequency noise.

4. Electrical Installation

- In order to reduce the likelihood of radio frequency interference affecting the operation of units it is recommended that neither units nor their cabling are installed in close proximity to the antennae of high powered radio, radar or satellite communication equipment.

4.4 Connections

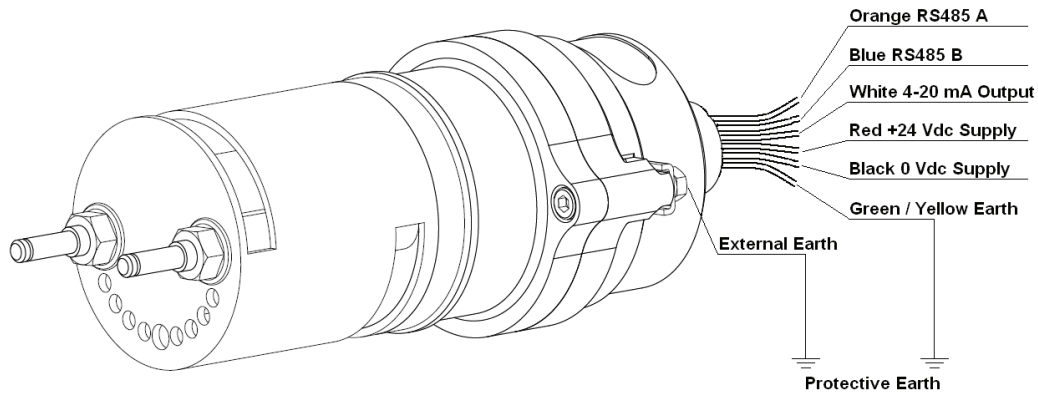

Wire Colour	Connection	Purpose
Red	+24 Vdc	+ve Supply
Black	0 Vdc	-ve Supply
White	4-20 mA Output	Signal
Orange	RS485 A	SHC1 Communication
Blue	RS485 B	SHC1 Communication
Green/Yellow	Earth	Protective Earth

Note: Searchpoint Optima Plus is reverse polarity protected.

The connection diagrams below show Searchpoint Optima Plus connected in current sink or current source mode.

Note: Searchpoint Optima Plus will automatically detect whether it should operate in current sink or current source mode.

Searchpoint Optima Plus Current Source Connection

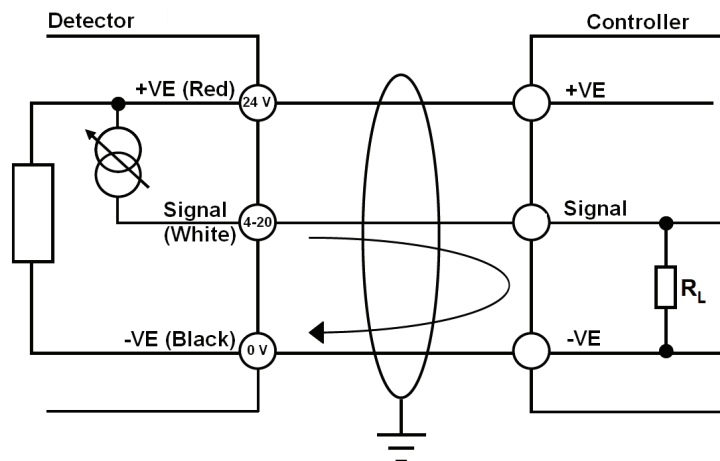

4. Electrical Installation

Searchpoint Optima Plus Current Sink Connection

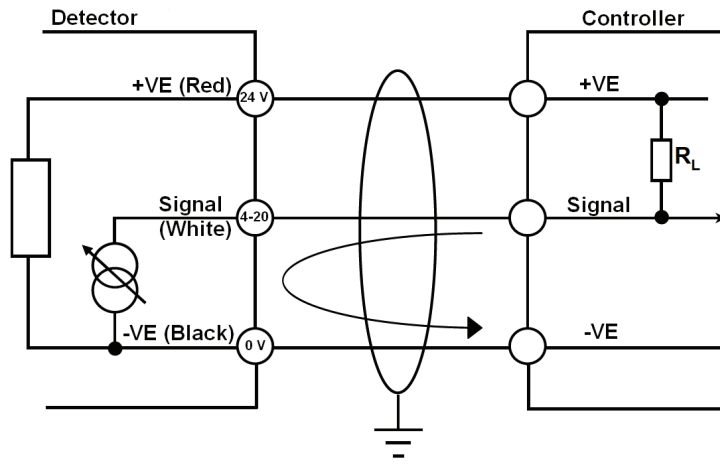

5. Operation

During normal operation, the 4-20 mA output represents 0-100 %FSD. The output is linear.

Analogue output below 4 mA represents diagnostic information. If the Searchpoint Optima Plus measures a negative gas reading, the analogue output will remain at 4 mA until the negative gas warning threshold is reached (-3 %FSD to -6 %FSD depending on the gas being measured) at which point it will signal a Warning.

5.1 Default Configuration

Status	Current output
Fault	< 1 mA
Warning	3 mA
Gas Reading	4 – 20 mA
Overrange	21 mA
Inhibit	2 mA

The tolerance on the nominal current output value is ± 0.2 mA.

During Warning status, the Searchpoint Optima Plus will continue to monitor gas, and will revert to Gas Reading status if a gas reading is detected.

If a Warning is indicated, schedule maintenance to investigate and rectify the cause. If left unattended, the unit is likely to enter Fault status, when it will be offline.

The Warning, Inhibit and Overrange signal levels can be configured using the HART® communications, or by a Honeywell Analytics Field Service Engineer as follows: -

Parameter	Range
Warning*	0 mA to 6 mA
Inhibit	1 mA to 3 mA
Overrange	20 mA to 21.6 mA

- * For ATEX compliance, the warning value should not be set > 3 and < 5 mA. If the warning value is set higher than 4 mA, the output signal will toggle between the warning value for 1 s and the current gas reading for 9 s.

5.2 HART® Operation during Fault

HART® communication requires > 1 mA current output for transmission, therefore if the HART® version of the Searchpoint Optima Plus goes into Fault the HART® communications will not work.

It is possible to configure the Fault output level of a Searchpoint Optima Plus unit with HART® to be 1 mA. This can be done during commissioning (see Commissioning using HART® Communications, Configure HART® Operation during Fault).

6. Commissioning

Read this chapter if the SHC1 Handheld Interrogator or the HART® communications are not being used.

6.1 First Time Switch On

Note: Searchpoint Optima Plus is supplied calibrated and ready for use. It does not require calibration during commissioning.

Note: During commissioning the 4-20 mA output can be monitored either at the control room or locally with a multimeter. When connecting or disconnecting a multimeter, power off the Searchpoint Optima Plus, otherwise the unit will indicate a latched warning that the 4-20 mA loop was broken. If this occurs it can be cleared by re-cycling the power.

1. Before applying power to the unit, ensure that the field wiring is correct and all electrical connections are in accordance with Section 4.
2. Apply power. Check that the supply voltage to the Searchpoint Optima Plus is between 18 and 32 V.
3. Monitor the 4-20 mA output during the start up sequence, which should be as follows: -

Current output	Duration
< 1 mA	< 5 s
2 ± 0.2 mA	< 60 s
4 ± 0.2 mA	ongoing

Note: If gas is present, the unit will indicate a gas reading.

Note: If the output reverts to 3 mA or < 1 mA, an active or latched Warning or Fault may be present. If this happens re-cycle the power. If the Warning or Fault persists, please refer to Chapter 14 Troubleshooting.

Searchpoint Optima Plus is factory calibrated and it is not necessary to calibrate or gas test it during commissioning. However if local regulations or site practices require that a gas test is done to check that the unit is functioning, please see Chapter 7 Maintenance, Bump Test for instructions.

7. Maintenance

Read this chapter if the SHC1 Handheld Interrogator or the HART® communications are not being used.

7.1 Introduction

This chapter explains how to perform common maintenance operations. Please refer to IEC/EN 60079-29-2 or other local or national regulations for guidance on establishing an appropriate maintenance routine.

Inspection	How to check and clean the unit
Inspection of a unit fitted with a Flow Housing	How to check and clean a unit fitted with a flow housing
Bump Test (Gas Challenge)	How to carry out a gas test using the Gassing Cover
Bump Test (Gas Challenge) with RGC	How to carry out a gas test using the Remote Gassing Cell

7.2 Inspection

Searchpoint Optima Plus should be inspected periodically and cleaned if necessary. The required frequency of inspection will depend on local site conditions and will need to be established through experience.

Caution: Gas readings may be generated during this procedure. Take appropriate action at the control and monitoring system to inhibit signals.

1. Inspect the Searchpoint Optima Plus unit, its junction box and cabling for any signs of physical damage.
2. Using a ½ inch / 13 mm A/F open ended spanner, unscrew the two retaining nuts and remove the Standard Weather Protection.
3. Inspect the Standard Weather Protection for damage or build up of debris / contaminants. If required, clean or replace weather protection.
4. Inspect the Dust Barrier and clean or replace if required.
5. Remove the Dust Barrier and inspect the optics.
6. Clean any dust or contaminants from the optics using mild detergent and a soft cloth or cotton bud. Do not use solvents or abrasive cleaners.
7. Replace the Dust Barrier and Standard Weather Protection.
8. Cycle the power to clear any faults or warnings that may have been generated by cleaning.

7.3 Inspection of a unit fitted with a Flow Housing

Searchpoint Optima Plus should be inspected periodically and cleaned if necessary. The required frequency of inspection will depend on local site conditions and will need to be established through experience.

Caution: Gas readings may be generated during this procedure. Take appropriate action at the control and monitoring system to inhibit signals.

1. Inspect the Searchpoint Optima Plus unit, its junction box and cabling for any signs of physical damage.
2. Disconnect any pipework attached to the flow housing.

7. Maintenance

3. Using a ½ inch / 13 mm A/F open ended spanner, remove the two black nuts which retain the flow housing.
Keep the O-ring seals which are below the retaining nuts.
4. Slide the flow housing off the Searchpoint Optima Plus. This may require some force due to the friction of the O-ring.
5. Clean any dust or contaminants from the optics using mild detergent and a soft cloth or cotton bud.
Do not use solvents or abrasive cleaners.
6. Ensure that the large sealing O-ring in the body of the flow housing, and the two small O-rings which go below the retaining nuts, are clean and in good condition. Replace if in doubt.
7. Slide the flow housing over the end of the Searchpoint Optima Plus and push until the flow housing is firmly seated.
8. Re-fit the o-rings and retaining nuts.
9. Cycle the power to clear any faults or warnings that may have been generated by cleaning.

7.4 Bump Test (Gas Challenge)

Searchpoint Optima Plus can be functionally checked using an appropriate test gas.

Caution: Gas readings will be generated during this procedure. Take appropriate action at the control and monitoring system to inhibit signals.

Note: The unit should be powered up for 1 hour before a gas test is done.

Note: During testing the 4-20 mA output can be monitored either at the control room or locally with a multimeter. When connecting or disconnecting a multimeter, power off the Searchpoint Optima Plus, otherwise the unit will indicate a latched warning that the 4-20 mA loop was broken. If this occurs it can be cleared by re-cycling the power.

1. Fit a Gassing Cover to the Searchpoint Optima Plus.
2. Apply an appropriate test gas at a rate of 1 – 1.5 litres per minute for ~ 30 - 60 s.
3. Check that the Searchpoint Optima Plus responds to the test gas. The reading should be within $\pm 20\%$ of the target.

Note: If the gas reading is not acceptable for the application, re-zero the Searchpoint Optima Plus and repeat the test. The SHC1 Handheld Interrogator, the HART® communication or the XNX Universal Transmitter is required to re-zero the Searchpoint Optima Plus. Factors to consider when evaluating the gas response include: -

- Test gas and concentration
- Tolerance of the test gas concentration
- Atmospheric pressure
- Ambient temperature
- Wind speed

4. Remove the Gassing Cover and wait for the test gas to clear (~ 30 s). Ensure that the gas reading has returned to zero.

7. Maintenance

7.5 Bump Test (Gas Challenge) with Remote Gassing Cell (RGC)

Using a test gas of 50 %v/v methane in the Remote Gassing cell (RGC), a gas response will be generated from most Searchpoint Optima Plus units. The reading depends on the target gas calibration of the unit. The RGC is a tool to check for a gas response and is not precise; therefore variability in response between units should be expected.

Caution: Gas readings will be generated during this procedure. Take appropriate action at the control and monitoring system to inhibit signals.

Caution: Maximum flow rate is 0.3 litres per minute to avoid pressurising the gas in the RGC.

Note: This procedure only applies if the Searchpoint Optima Plus has a Remote Gassing Cell (RGC) fitted. The RGC is a factory fitted option.

Note: During testing the 4-20 mA output can be monitored either at the control room or locally with a multimeter. When connecting or disconnecting a multimeter, power off the Searchpoint Optima Plus, otherwise the unit will indicate a latched warning that the 4-20 mA loop was broken. If this occurs it can be cleared by re-cycling the power.

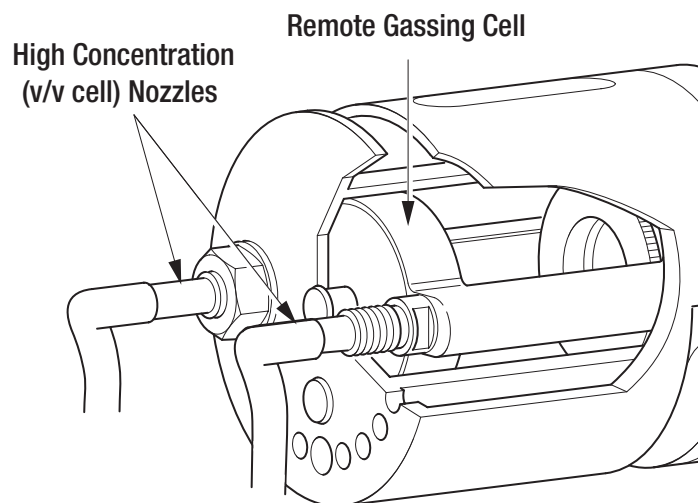

1. Inspect the gassing pipes to the RGC. Ensure that the exhaust is clear and vents well away from the Searchpoint Optima Plus, and does not cause a hazard.
2. Apply 50 %v/v methane at a rate of 0.3 litres per minute for ~ 30 - 60 s. (For long gas pipes > ~10 m, allow a longer time for the gas to reach Searchpoint Optima Plus).
3. Check that the Searchpoint Optima Plus responds to the test gas.

Note: If the gas reading is not acceptable for the application, re-zero the Searchpoint Optima Plus and repeat the test. The SHC1 Handheld Interrogator, the HART® communication or the XNX Universal Transmitter is required to re-zero the Searchpoint Optima Plus.

4. Flush the RGC with zero gas until the gas reading has returned to zero.

8. Use of the SHC1 Handheld Interrogator

Read this chapter if the SHC1 Handheld Interrogator is being used to communicate with Searchpoint Optima Plus.

8.1 Introduction

This chapter explains how to connect the SHC1 Handheld Interrogator to the Searchpoint Optima Plus and how to operate it. It also provides the menu structure for use with Searchpoint Optima Plus.

The SHC1 Handheld Interrogator is a portable, intrinsically safe device which can be used to calibrate, test and commission all of Honeywell Analytics Searchpoint and Searchline optical gas detection products. The SHC1 Handheld Interrogator uses the detector's communications link.

Note: The SHC1 Handheld Interrogator does not read the HART® communications.

Note: The HART® communication takes precedence over the RS485 communication used by the SHC1 Handheld Interrogator. If the Searchpoint Optima Plus is being polled simultaneously by a HART® host, temporary communication errors may be experienced by the SHC1 Handheld Interrogator.

8.2 SHC1 Connection

WARNING

Do not attempt to connect the SHC1 Handheld Interrogator directly to Searchpoint Optima Plus. Always use a DVC100 series termination unit, or the SHC Protection Device.

Connect the SHC1 Handheld Interrogator to the gas detector in one of the following ways:

1. With a Honeywell Analytics DVC100 Junction Box, connect the Interrogator directly to the junction box via the IS socket.

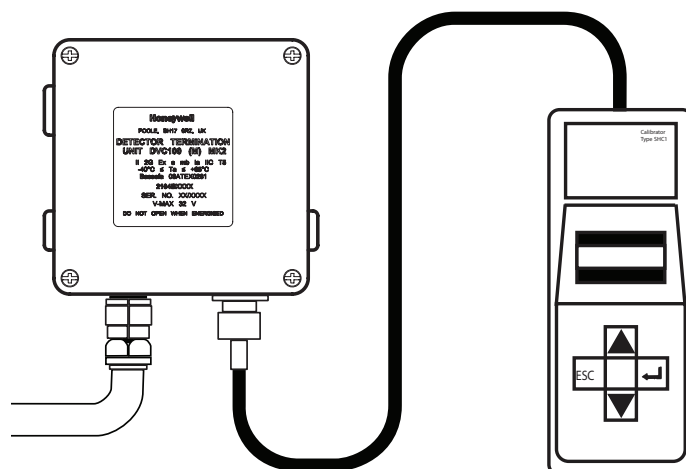

2. With any other type of junction box use the SHC Protection Device (also see Section 4 Electrical Installation).

8. Use of the SHC1 Handheld Interrogator

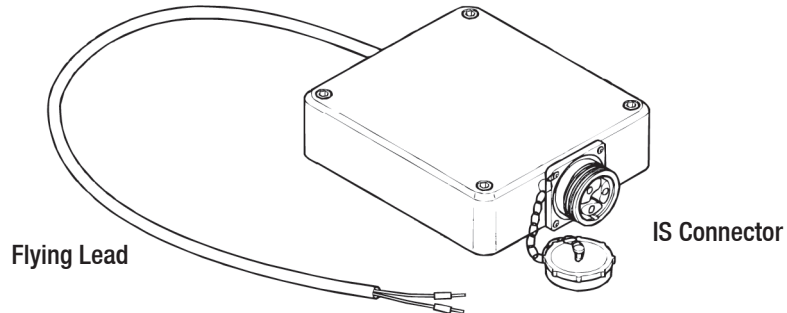

Note: The protection device must always be used for this type of connection. A hot work permit may be required for this procedure.

Carry out the following procedure to connect using the protection device.:

1. Isolate all power supplies.
2. Remove the cover of the junction box.
3. Hard wire the flying lead of the SHC Protection Device to the communications link terminals in the box as shown:

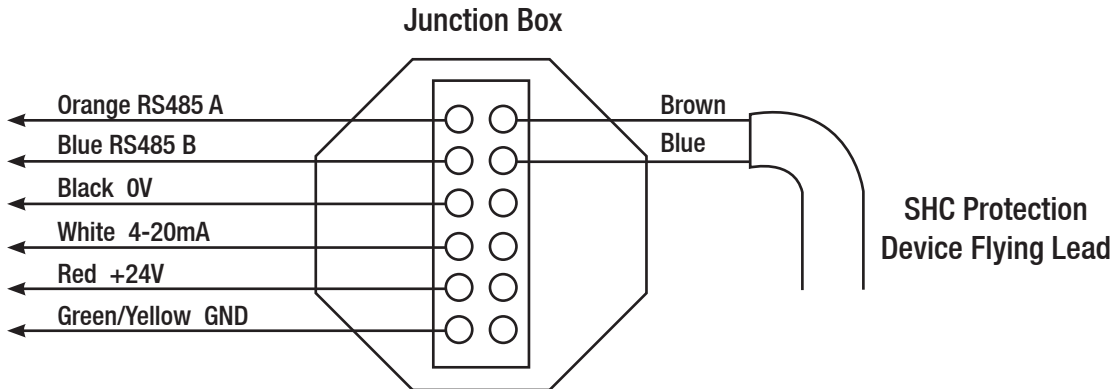

4. Connect the Interrogator to the IS connector on the end of the SHC Protection Device.

8. Use of the SHC1 Handheld Interrogator

8.3 SHC1 Operation

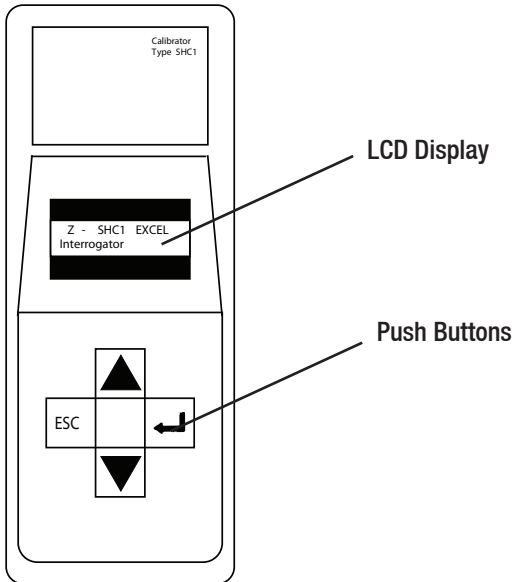

Press \leftarrow and hold for three seconds to switch on.
 Press \leftarrow and esc together and hold to switch off.
 Unit powers down automatically after 10 minutes to prolong battery life.

The diagram below shows the SHC1 menu structure.

- Use the ▲ and ▼ keys to scroll through the menu options.
- Press **Enter** (↵) to select an option and **Escape (esc)** to exit.

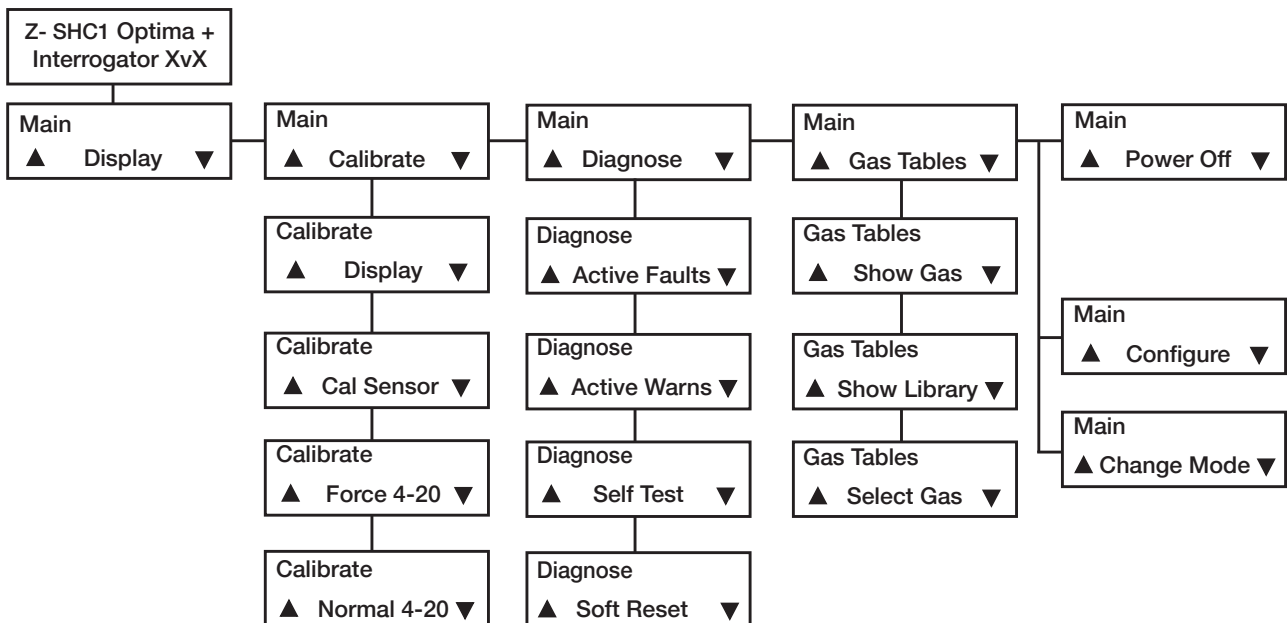

8. Use of the SHC1 Handheld Interrogator

When the SHC1 is switched on, check that it displays Optima+ on the initial screen. If it shows Optima or Excel, or reports “Comms Error 99”, change the operating mode as follows: -

1. Select **Change Mode**.
2. Use the ▲ and ▼ keys to scroll through the options until Optima+ is highlighted.
3. Press **Enter** to select.

The SHC1 returns to the main menu.

Note: The instructions that follow in this manual assume that the SHC1 is switched on, in Optima+ mode, in the Main Menu.

8.4 Status indication

When **Display** is selected, the screen includes a status character which indicates the Searchpoint Optima Plus status (warning, fault etc.) as follows: -

- / A spinning line shows the system is operating normally i.e. in a fully active state
- | A stationery line shows the system is in inhibit
- W** Active Warning
- F** Active Fault
- A** Alarm

Press **Enter** to view the software version of Searchpoint Optima Plus.

8.5 SHC1 Battery Replacement

To replace the battery in the SHC1 Handheld Interrogator proceed as follows:

Note: To comply with certification, only use DURACELL MN1604 Type 6LR61

1. Remove the Interrogator from its protective pouch.
2. Using a 2.5mm allen hexagonal key, loosen the four screws on the rear cover of the Interrogator.
3. Carefully lift the front half of the Interrogator away from the rear cover, ensuring the flexible connector connecting the key pad to the electronics module is not damaged.
4. Unclip the old battery and fit the new battery in position. Re-use the protective sleeve.
5. Carefully replace the front half of the Interrogator back into the rear cover, ensuring the flexible connector lies flat.
6. Using a 2.5mm allen hexagonal key, tighten the four screws on the rear cover of the Interrogator.

When the battery reaches end of life, take it to a collection point designated by local authorities.

9. Commissioning using SHC1 Handheld Interrogator

Read this chapter if the SHC1 Handheld Interrogator is being used to communicate with Searchpoint Optima Plus.

Note: The instructions that follow assume that the SHC1 is switched on, in Optima+ mode, in the Main Menu. See Chapter 8 “Use of the SHC1 Handheld Interrogator” for details.

9.1 Introduction

This chapter explains several operations that may be required during commissioning. Only First Time Switch On is mandatory; Test 4-20 mA Loop Integrity is recommended. The instructions assume that the SHC1 is switched on, in Optima+ mode, in the Main Menu. See Chapter 8 “Use of the SHC1 Handheld Interrogator” for details.

First Time Switch On	Checks that are required on first power up
Clear Faults or Warnings	How to clear faults or warnings that may be generated during commissioning
Fix the 4-20 mA Output	How to force the mA output to set levels in order to calibrate the controller or to test the system
Test 4-20 mA Loop Integrity	Check that there is sufficient compliance in the loop to signal alarm and overrange

Caution: After changing any parameter, poll the Searchpoint Optima Plus and verify that the received value is correct.

9.2 First Time Switch On

Note: Searchpoint Optima Plus is supplied calibrated and ready for use. It does not require calibration during commissioning.

Note: During commissioning the 4-20 mA output can be monitored either at the control room or locally with a multimeter. When connecting or disconnecting a multimeter, power off the Searchpoint Optima Plus, otherwise the unit will indicate a latched warning that the 4-20 mA loop was broken. If this occurs it can be cleared using the SHC1 Handheld Interrogator.

1. Before applying power to the unit, ensure that the field wiring is correct and all electrical connections are in accordance with Section 4.
2. Apply power. Check that the supply voltage to the Searchpoint Optima Plus is between 18 and 32 V.
3. Monitor the 4-20 mA output during the start up sequence, which should be as follows: -

Current output	Duration
<1 mA	< 5 s
2 ± 0.2 mA	< 60 s
4 ± 0.2 mA	ongoing

Note: If gas is present, the unit will indicate a gas reading.

9. Commissioning using SHC1 Handheld Interrogator

Note: If the output reverts to 3 mA or < 1 mA, a Warning or Fault is present. Follow the instructions below to investigate and clear a warning or fault (see Clear Faults or Warnings).

Searchpoint Optima Plus is factory calibrated and it is not necessary to calibrate or gas test it during commissioning. However if local regulations or site practices require that a gas test is done to check that the unit is functioning, please see Chapter 10 Maintenance, Bump Test for instructions.

9.3 Clear Faults or Warnings

During commissioning, faults or warnings may be generated. This will be indicated by the 4-20 mA output signal. Use the procedure below to clear them.

1. Select **Diagnose** then **Active Faults**, or **Diagnose** then **Active Warnings** to view any faults or warnings.

Note: If no active faults or warnings are present, the 4-20 mA output signal may have latched due to an earlier fault or warning that has now cleared. Proceed to step 3 to clear latched faults or warnings.

2. Use the Problem Solving section of this manual to rectify the issue.
3. Select **Diagnose** then **Soft Reset** to clear any latched warnings or faults.

Note: If any configuration changes have been made, wait 15 seconds before doing a soft reset or cycling the power.

4. Press **Escape** to return to the main menu.

9.4 Fix the 4-20 mA Output

The 4-20 mA output can be set to a fixed value between 1 mA and 21 mA, which can be used to calibrate the controller or to test the system.

Note: This function will timeout after 10 minutes of inactivity.

Note: When connecting or disconnecting a multimeter, power off the Searchpoint Optima Plus, otherwise the unit will indicate a latched warning that the 4-20 mA loop was broken. If this occurs it can be cleared using the SHC1 Handheld Interrogator. See Clear Faults or Warnings.

1. Select **Calibrate** then **Force 4-20**.
2. Use **▲** and **▼** to set the required mA value and press **Enter**.

Searchpoint Optima Plus will now output the set mA value.

3. When calibration is complete, press **Enter**.
4. Press **Enter** to release the 4-20 mA output signal.
5. Press **Escape** to return to the main menu.

9. Commissioning using SHC1 Handheld Interrogator

9.5 Test 4-20 mA Loop Integrity

It is recommended that the 4-20 mA loop integrity is tested by setting the Searchpoint Optima Plus to output an overrange current. This will confirm that there are no faults in the system that would cause a current limit.

Note: This function will timeout after 10 minutes of inactivity.

Note: When connecting or disconnecting a multimeter, power off the Searchpoint Optima Plus, otherwise the unit will indicate a latched warning that the 4-20 mA loop was broken. If this occurs it can be cleared using the SHC1 Handheld Interrogator. See Clear Faults or Warnings.

1. Select **Calibrate** then Force 4-20.
2. Use **▲** and **▼** to set the mA value to 21 mA and press **Enter**.

Searchpoint Optima Plus will now output 21 mA.

3. Check that the signal at the controller is > 20 mA, then press **Enter**.
4. Press **Enter** to release the 4-20 mA output signal.
5. Press **Escape** to return to the main menu.

Note: If the current at the controller is not correct, check the 4-20 mA loop connections and cabling, and check that the loop resistance is less than 600 Ω . In current source mode, for supply voltages of 18 to 20 Vdc the maximum loop resistance is 500 Ω .

10. Maintenance using SHC1 Handheld Interrogator

Read this chapter if the SHC1 Handheld Interrogator is being used to communicate with Searchpoint Optima Plus.

Note: The instructions that follow assume that the SHC1 is switched on, in Optima+ mode, in the Main Menu. See Chapter 8 “Use of the SHC1 Handheld Interrogator” for details.

10.1 Introduction

This chapter explains how to perform common maintenance operations. Please refer to IEC/EN 60079-29-2 or other local or national regulations for guidance on establishing an appropriate maintenance routine. The instructions assume that the SHC1 is switched on, in Optima+ mode, in the Main Menu. See Chapter 8 “Use of the SHC1 Handheld Interrogator” for details.

Inspection	How to check and clean the unit
Inspection of a unit fitted with a Flow Housing	How to check and clean a unit fitted with a flow housing
Bump Test (Gas Challenge)	How to carry out a gas test using the Gassing Cover
Bump Test (Gas Challenge) with RGC	How to carry out a gas test using the Remote Gassing Cell
Re-zero Searchpoint Optima Plus	How to re-zero if gas test results are unacceptable
Calibration	How to calibrate the zero (and span if required)
View and Clear Faults or Warnings	How to view Faults and Warnings

Caution: After changing any parameter, poll the Searchpoint Optima Plus and verify that the received value is correct.

Note: When connecting or disconnecting a multimeter, power off the Searchpoint Optima Plus, otherwise the unit will indicate a latched warning that the 4-20 mA loop was broken. If this occurs it can be cleared using the SHC1 Handheld Interrogator. See Clear Faults or Warnings.

10.2 Inspection

Searchpoint Optima Plus should be inspected periodically and cleaned if necessary. The required frequency of inspection will depend on local site conditions and will need to be established through experience.

Caution: Gas readings may be generated during this procedure.

1. Select **Calibrate** then **Display** to inhibit the 4-20 mA output signal.
2. Inspect the Searchpoint Optima Plus unit, its junction box and cabling for any signs of physical damage.
3. Using a ½ inch / 13 mm A/F open ended spanner, unscrew the two retaining nuts and remove the Standard Weather Protection.
4. Inspect the Standard Weather Protection for damage or build up of debris / contaminants. If required, clean or replace weather protection.
5. Inspect the Dust Barrier and clean or replace if required.
6. Remove the Dust Barrier and inspect the optics.
7. Clean any dust or contaminants from the optics using mild detergent and a soft cloth or cotton bud. Do not use solvents or abrasive cleaners.

10. Maintenance using SHC1 Handheld Interrogator

8. Replace the Dust Barrier and Standard Weather Protection.
9. Press **Escape** then **Enter** to release the 4-20 mA output signal.
10. Press **Escape** to return to the main menu.
11. Select **Diagnose** then **Soft Reset** to clear any faults or warnings that may have been generated by cleaning.

Note: If any configuration changes have been made, wait 15 seconds before doing a soft reset or cycling the power.

12. Press **Escape** to return to the main menu.

10.3 Inspection of a unit fitted with a Flow Housing

Searchpoint Optima Plus should be inspected periodically and cleaned if necessary. The required frequency of inspection will depend on local site conditions and will need to be established through experience.

Caution: Gas readings may be generated during this procedure.

1. Select **Calibrate** then **Display** to inhibit the 4-20 mA output signal.
2. Inspect the Searchpoint Optima Plus unit, its junction box and cabling for any signs of physical damage.
3. Disconnect any pipework attached to the flow housing.
4. Using a ½ inch / 13 mm A/F open ended spanner, remove the two black nuts which retain the flow housing. Keep the O-ring seals which are below the retaining nuts.
5. Slide the flow housing off the Searchpoint Optima Plus. This may require some force due to the friction of the O-ring.
6. Clean any dust or contaminants from the optics using mild detergent and a soft cloth or cotton bud. Do not use solvents or abrasive cleaners.
7. Ensure that the large sealing O-ring in the body of the flow housing, and the two small O-rings which go below the retaining nuts, are clean and in good condition. Replace if in doubt.
8. Slide the flow housing over the end of the Searchpoint Optima Plus and push until the flow housing is firmly seated.
9. Re-fit the o-rings and retaining nuts.
10. Press **Escape** then **Enter** to release the 4-20 mA output signal.
11. Press **Escape** to return to the main menu.
12. Select **Diagnose** then **Soft Reset** to clear any faults or warnings that may have been generated by cleaning.

Note: If any configuration changes have been made, wait 15 seconds before doing a soft reset or cycling the power.

13. Press **Escape** to return to the main menu.

10. Maintenance using SHC1 Handheld Interrogator

10.4 Bump Test (Gas Challenge)

Searchpoint Optima Plus can be functionally checked using an appropriate test gas.

Caution: Gas readings will be generated during this procedure.

Note: The unit should be powered up for 1 hour before a gas test is done.

1. Select **Calibrate** then **Display**. (This will inhibit the 4-20 mA output signal).
2. Fit a Gassing Cover to the Searchpoint Optima Plus, if not already in place.
3. Apply an appropriate test gas at a rate of 1 – 1.5 litres per minute for ~ 30 - 60 s.
4. Check that the Searchpoint Optima Plus responds to the test gas. The reading should be within ± 20 % of target.

Note: If the gas reading is not acceptable for the application, re-zero the Searchpoint Optima Plus and repeat the test. Factors to consider when evaluating the gas response include: -

- Test gas and concentration
- Tolerance of the test gas concentration
- Atmospheric pressure
- Ambient temperature
- Wind speed

5. Remove the Gassing Cover and wait for the test gas to clear (~ 30 s). Ensure that the gas reading has returned to zero.
6. Press **Escape** then **Enter** to release the 4-20 mA output signal.
7. Press **Escape** to return to the main menu.

10.5 Bump Test (Gas Challenge) with Remote Gassing Cell (RGC)

Using a test gas of 50 %v/v methane in the Remote Gassing cell (RGC), a gas response will be generated from most Searchpoint Optima Plus units. The reading depends on the target gas calibration of the unit. The RGC is a tool to check for a gas response and is not precise; therefore variability in response between units should be expected.

Caution: Gas readings will be generated during this procedure.

Caution: Maximum flow rate is 0.3 litres per minute to avoid pressurising the gas in the RGC.

Note: This procedure only applies if the Searchpoint Optima Plus has a Remote Gassing Cell (RGC) fitted. The RGC is a factory fitted option.

10. Maintenance using SHC1 Handheld Interrogator

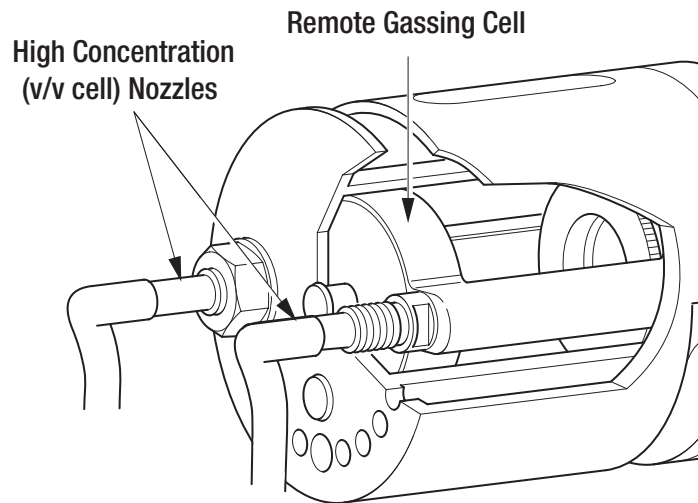

1. Inspect the gassing pipes to the RGC. Ensure that the exhaust is clear and vents well away from the Searchpoint Optima Plus, and does not cause a hazard.
2. Select **Calibrate** then **Display**. (This will inhibit the 4-20 mA output signal).
3. Apply 50 %v/v methane at a rate of 0.3 litres per minute for ~ 30 - 60 s. (For long gas pipes > ~10 m, allow a longer time for the gas to reach Searchpoint Optima Plus).
4. Check that the Searchpoint Optima Plus responds to the test gas.

Note: If the gas reading is not acceptable for the application, re-zero the Searchpoint Optima Plus and repeat the test.

5. Flush the RGC with zero gas until the gas reading has returned to zero.
6. Press **Escape** then Enter to release the 4-20 mA output signal.
7. Press **Escape** to return to the main menu.

10.6 Re-zero Searchpoint Optima Plus

Re-zero Searchpoint Optima Plus if it has given an unexpected response to a gas test. In most cases a re-zero will restore accuracy and a full span calibration is not required.

1. Select **Calibrate** then **CalSensor**. (This will inhibit the 4-20 mA output signal).
2. Ensure that there is zero gas present in the vicinity of the Searchpoint Optima Plus. If necessary, fit a Gassing Cover and apply zero gas.
3. Press **Enter**.

When the process is complete the display will state Zero Calibrated. It will then show options to continue to a span calibration, or to exit calibration.

4. Press **Escape** to exit calibration.
5. Press **Enter** to release the 4-20 mA output signal.
6. Press **Escape** to return to the main menu.

Note: If the option to Calibrate Span is selected in error, press Escape.

10. Maintenance using SHC1 Handheld Interrogator

10.7 Calibration

Searchpoint Optima Plus is factory calibrated and does not require routine calibration. In most cases, a re-zero will correct any inaccuracy in the gas reading. It is strongly recommended that a span calibration is not carried out.

In the unlikely event that a span calibration is required, use a cylinder of the target gas, of approximately 50 %FSD, with an accuracy of at least $\pm 2\%$.

Note: Searchpoint Optima Plus will accept a span calibration gas concentration of between 30 %FSD and 125 %FSD, however this facility is reserved for use in specialist applications.

Do not calibrate Searchpoint Optima Plus during periods of very high or low atmospheric pressure, very strong winds or storms.

Caution: Gas readings will be generated during this procedure.

Note: The unit should be powered up for 1 hour before a calibration is done.

1. Using a ½ inch / 13 mm A/F open ended spanner, unscrew the two retaining nuts and remove the Standard Weather Protection.
2. Fit a Calibration Cap to the Searchpoint Optima Plus. Ensure it is pushed on fully.
3. Select **Calibrate** then **CalSensor**. (This will inhibit the 4-20 mA output signal).
4. Ensure that there is zero gas present in the vicinity of the Searchpoint Optima Plus. If necessary, apply zero gas at a rate of 1 – 1.5 litres per minute.
5. Press **Enter**.

When the process is complete the display will state Zero Calibrated. It will then show options to continue to a span calibration, or to exit calibration.

6. Press **Enter** to begin span calibration.
7. Press **Enter**.
8. Use **▲** and **▼** to set the concentration of the calibration gas. When it is correct, press **Enter**.
9. Apply calibration gas at a rate of 1 – 1.5 litres per minute. Wait for the gas reading to stabilise (~ 30 - 60 s).
10. Press **Enter**.

When the process is complete the display will show Span Calibrated. It will then show an instruction to remove gas.

11. Remove the Calibration Cap and wait for the test gas to clear (~ 30 s). Ensure that the gas reading has returned to zero.
12. Press **Enter**.
13. Refit the Standard Weather Protection and the two retaining nuts.
14. Press **Enter** to release the 4-20 mA output signal.
15. Press **Escape** to return to the main menu.

10. Maintenance using SHC1 Handheld Interrogator

10.8 Investigation of Faults or Warnings

If the unit is signalling Fault or Warning on the 4-20 mA output, the problem should be investigated and remedied as soon as possible. Some types of faults and warnings are latching and will need to be cleared by a Reset.

1. Select **Diagnose** then **Active Faults**, or **Diagnose** then **Active Warnings** to view any faults or warnings.

Note: If no active faults or warnings are present, the 4-20 mA output signal may be due to a latched fault or warning. Proceed to step 3.

2. Use the Problem Solving section of this manual (Chapter 14) to rectify the issue.
3. Select **Diagnose** then **Soft Reset** to clear any latched warnings or faults.

Note: If any configuration changes have been made, wait 15 seconds before doing a soft reset or cycling the power.

4. Press **Escape** to return to the main menu.

11. Use of the HART® Communications

Read this chapter if HART® communications are being used to communicate with Searchpoint Optima Plus.

11.1 General

The HART® version of the Searchpoint Optima Plus can communicate using the HART® protocol. HART® devices provide digital communications superimposed on the standard analogue output. Detailed information about the HART® protocol can be found at the HART® Communication Foundation's website www.hartcomm.org.

HART® is a master-slave protocol, i.e. the Searchpoint Optima Plus does not continually transmit data but will respond on request.

Searchpoint Optima Plus has a HART® Device Description (DD) file, which is provided on the CD supplied with the product, or available to download from Honeywell Analytics website www.honeywellanalytics.com or the HART® Foundation website www.hartcomm.org.

The DD file is written using HART® version 7, and is compatible with HART® DD Tokenizer versions 6 and 8. The DD file is supplied in .fm6, .fm8, .hhd and .hdd versions. It is compatible with a wide range of industry standard products.

To use the HART® communications, load the Searchpoint Optima Plus DD file into a suitable HART® host (see manufacturer's instructions).

11.2 Connection

It is best to use a dedicated HART® interface point (for example the HALO* junction box) to connect a HART® handheld device.

If such an interface is not available, it is possible to connect to the HART® signal across a load resistor in the current loop. For example, provided there is the minimum resistance of 230 Ω in the 4-20 mA loop, the HART® handheld device can be connected across the terminals in the junction box.

* Contact Honeywell Analytics for availability

11.3 Searchpoint Optima Plus User Interface

11.3.1 Access Levels and Password Protection

The Searchpoint Optima Plus user interface has three access levels. Default and Level 1 are available to the user, while Level 2 access is restricted to Honeywell Field Service personnel.

The Default level is read-only and displays information about the current gas reading, configuration and unit status, including active warnings and faults.

Level 1 access is required to test and calibrate the unit, and to make changes to the default configuration. Level 1 access is password protected. The password is 8 digit alphanumeric (case sensitive), and it is recommended that the user sets this to a password of their choosing. To avoid potential compatibility issues between different HART® host devices, ensure that a full 8 digit password is used.

11. Use of the HART® Communications

The Level 1 password is factory set to 00000000 (eight zeroes). Instructions to change the password are included in Chapter 12 Commissioning, User Configuration.

Note: Some HART® handheld devices will retain the previous login until switched off, even if the Searchpoint Optima Plus is disconnected. Ensure that Level 1 access is protected from unauthorised use by logging off when appropriate.

11.3.2 Menu Structure

The welcome screen displays current information about the Searchpoint Optima Plus.

WELCOME SCREEN	
	Example Data
1 Device Setup	
2 Gas Concentration	0 %LEL
4 PV Loop current	4 mA
5 Active Gas Table	Methane
6 Operating Mode	Healthy
7 Loop Current Mode	Point to Point HART Mode
8 Time (24-hour)	15:47
9 Date (dd/mm/yyyy)	16/07/2010

Selecting Device Setup leads to the further menu options, depending on the access level of the user.

The menu structures are given below (xxxx represents information, ?? represents a user text field): -

DEVICE SETUP MENU – DEFAULT ACCESS LEVEL			
1 Device Setup	1 User	Default	Default
	2 User Login		Level 1
	3 Unit Status		Level 2
1 Device Setup	1 User	Default	1 Operating Mode xxxx
	2 User Login		2 Active Warnings
	3 Unit Status		3 Active Faults

11. Use of the HART® Communications

DEVICE SETUP MENU – LEVEL 1 ACCESS		
1 Device Setup	1 User Level 1 2 User Login 3 Unit Status 4 Gas Configuration 5 Test 6 Calibrate 7 User Configuration 8 Assembly Details 9 Device Info	Default Level 1 Level 2
1 Device Setup	1 User Level 1 2 User Login 3 Unit Status 4 Gas Configuration 5 Test 6 Calibrate 7 User Configuration 8 Assembly Details 9 Device Info	1 Operating Mode xxxx 2 Active Warnings 3 Active Faults 4 Event History
1 Device Setup	1 User Level 1 2 User Login 3 Unit Status 4 Gas Configuration 5 Test 6 Calibrate 7 User Configuration 8 Assembly Details 9 Device Info	1 Alarm Threshold Configuration 2 Gas Selection
1 Device Setup	1 User Level 1 2 User Login 3 Unit Status 4 Gas Configuration 5 Test 6 Calibrate 7 User Configuration 8 Assembly Details 9 Device Info	1 Inhibit 2 mA loop test 3 Self test 4 Device reset 5 Simulate Alarm Fault
1 Device Setup	1 User Level 1 2 User Login 3 Unit Status 4 Gas Configuration 5 Test 6 Calibrate 7 User Configuration 8 Assembly Details 9 Device Info	1 Inhibit 2 Bump Test 3 Gas Concentration xxxx 4 mA Loop Calibration 5 Gas Calibration 6 Calibration Info ??

11. Use of the HART® Communications

1 Device Setup	1 User Level 1 2 User Login 3 Unit Status 4 Gas Configuration 5 Test 6 Calibrate 7 User Configuration 8 Assembly Details 9 Device Info	1 HART During Fault xxxx 2 Inhibit Current xxxx 3 Warning Current xxxx 4 Overrange Current xxxx 5 Set Time (24 hour) 6 Set Date (dd/mm/yyyy) 7 Change Password
1 Device Setup	1 User Level 1 2 User Login 3 Unit Status 4 Gas Configuration 5 Test 6 Calibrate 7 User Configuration 8 Assembly Details 9 Device Info	1 Config Revision xxxx 2 HART Address xxxx 3 Description ?? 4 Assembly Date ?? 5 Assembly Number ?? 6 Device Tag ?? 7 Transmitter ID
1 Device Setup	1 User Level 1 2 User Login 3 Unit Status 4 Gas Configuration 5 Test 6 Calibrate 7 User Configuration 8 Assembly Details 9 Device Info	1 Loop Current Mode xxxx 2 Num req preams xxxx 3 Num resp preams xxxx 4 Dev id xxxx 5 Universal rev xxxx 6 Fld dev rev xxxx 7 Software rev xxxx 8 Hardware rev xxxx

11.3.3 Menu Navigation

Menu options can be selected by highlighting the option and pressing Enter, by pressing the number of the option, or by double clicking on the option. For more information on how to select menu options please see the instructions for the HART® host device being used.

11.3.4 Error Reporting

Searchpoint Optima Plus implements HART® protocol Command 48, meaning that if any event is detected in the unit while a HART® host is connected, it will be reported immediately. Therefore warning messages may pop up during other operations.

12. Commissioning using HART® Communications

Read this chapter if HART® communications are being used to communicate with Searchpoint Optima Plus.

Note: The instructions that follow assume that a suitable HART® host (handheld or PC) is connected to the Searchpoint Optima Plus and that the user is logged in with Level 1 access privileges. See Chapter 11 “Use of the HART® Communications” for details.

12.1 Introduction

This chapter explains several operations that may be required during commissioning. The user should work through First Time Switch On, User Configuration and Configure Device Identification Information, before selecting further operations as required by the specific installation.

First Time Switch On	Checks that are required on first power up
User Configuration	How to change settings from the default values: - Change the Password – How to change the password for Level 1 access Configure HART® Operation during Fault - How to change the Fault output level to 1 mA so that HART® will operate during Fault Set the Time and Date - How to adjust the real time clock to local time Configure Warning, Inhibit and Overrange Signal Levels - How to change the signal levels from the default settings
Configure Device Identification Information	How to set text fields that may be useful for device identification
Fix the 4-20 mA Output	How to force the mA output to set levels in order to calibrate the controller or test the system
Test 4-20 mA Loop Integrity	How to check that there is sufficient compliance in the loop to signal alarm and overrange
Calibrate the 4-20 mA Loop	How to calibrate the current output (note this is not a gas calibration)
Configure Internal Alarm Threshold	How to change the internal threshold used to simulate Alarm and log gas events
Simulation	How to test the system by simulating Alarm, Warning and Fault conditions
Clear Faults or Warnings	How to clear faults or warnings that may be generated during commissioning

Caution: After changing any parameter, poll the Searchpoint Optima Plus and verify that the received value is correct.

Note: The instructions that follow assume that a suitable HART® host (handheld or PC) is connected to the Searchpoint Optima Plus and that the user is logged in with Level 1 access privileges. See Chapter 11 “Use of the HART® Communications” for details.

12. Commissioning using HART® Communications

12.2 First Time Switch On

Note: Searchpoint Optima Plus is supplied calibrated and ready for use. It does not require calibration during commissioning.

Note: During commissioning the 4-20 mA output can be monitored either at the control room or locally with a multimeter. When connecting or disconnecting a multimeter, power off the Searchpoint Optima Plus, otherwise the unit will indicate a latched warning that the 4-20 mA loop was broken. If this occurs it can be cleared using the HART® communications.

1. Before applying power to the unit, ensure that the field wiring is correct and all electrical connections are in accordance with Section 4.
2. Apply power. Check that the supply voltage to the Searchpoint Optima Plus is between 18 and 32 V.
3. Monitor the 4-20 mA output during the start up sequence, which should be as follows: -

Current output	Duration
< 1 mA	< 5 s
2 ± 0.2 mA	< 60 s
4 ± 0.2 mA	ongoing

Note: If gas is present, the unit will indicate a gas reading

Note: If the output reverts to 3 mA or < 1 mA, a Warning or Fault is present. Follow the instructions below to investigate and clear a warning or fault (see Clear Faults or Warnings).

Searchpoint Optima Plus is factory calibrated and it is not necessary to calibrate or gas test it during commissioning. However if local regulations or site practices require that a gas test is done to check that the unit is functioning, please see Chapter 13 Maintenance, Bump Test for instructions.

12.3 User Configuration

12.3.1 Change the Password

It is recommended that the password for Level 1 access should be changed from the default setting. The password is 8 digit alphanumeric (case sensitive). A full 8 digit password should be used.

1. Select **Device Setup**.
2. Select **User Login**.
3. Select **Level 1**.
4. Enter the password 00000000 (eight zeroes) and press **Enter**.
5. The display shows a confirmation message, press **OK**.
6. Select **User Configuration**.
7. Select **Change Password**.
8. The display shows a confirmation message, press **OK**.

12. Commissioning using HART® Communications

9. Type in the new password and press **Enter**.

Note: Some HART® handheld devices contain a default password or hold a previously used password. Ensure that the desired password is typed in before pressing Enter.

10. The display shows a confirmation message, press **OK**.
11. Proceed to Configure HART® Operation during Fault, step 3, or press **Back** to return to the Device Setup menu.

12.3.2 Configure HART® Operation during Fault

Searchpoint Optima Plus is shipped with the Fault output current level set to < 1 mA. If the unit enters a Fault condition, the HART® communications will not work (HART® communications require > 1 mA to operate). The Fault output current level can be changed to 1 mA so that HART® communications remain active during a Fault condition.

1. Select **Device Setup**.
2. Select **User Configuration**.
3. Select **HART During Fault**.
4. Select **HART ACTIVE** and press **Enter**.
5. Press **Send** to send the information to Searchpoint Optima Plus.
6. Proceed to Set the Time and Date, step 3, or press **Back** to return to the Device Setup menu.

12.3.3 Set the Time and Date

Searchpoint Optima Plus has a real time clock, which is factory set to UK time. It can be adjusted to local time.

1. Select **Device Setup**.
2. Select **User Configuration**.
3. Select **Set Time**.
4. Enter the correct time (24 hour format) and press **Enter**.
5. The display shows a confirmation message, press **OK**.
6. Select **Set Date**.
7. Enter the correct date (dd/mm/yyyy format) and press **Enter**.
8. The display shows a confirmation message, press **OK**.
9. Proceed to Configure Warning, Inhibit and Overrange Signal Levels, step 3, or press **Back** to return to the Device Setup menu.

12. Commissioning using HART® Communications

12.3.4 Configure Warning, Inhibit and Overrange Signal Levels

The Warning, Inhibit and Overrange signal levels can be changed from the default values. The default levels and ranges are: -

Parameter	Default	Range
Warning*	3 mA	0 mA to 6 mA
Inhibit	2 mA	1 mA to 3 mA
Overrange	21 mA	20 mA to 21.6 mA

* For ATEX compliance, the warning value should not be set > 3 and < 5 mA. If the warning value is set higher than 4 mA, the output signal will toggle between the warning value for 1 s and the current gas reading for 9 s.

The tolerance on the nominal current output value is ± 0.2 mA.

1. Select **Device Setup**.
2. Select **User Configuration**.
3. Select **Inhibit Current**.
4. Enter the new value for the current within the allowed range and press **Enter**.
5. Select **Warning Current**.
6. Enter the new value for the current within the allowed range and press **Enter**.
7. Select **Overrange Current**.
8. Enter the new value for the current within the allowed range and press **Enter**.
9. Press **Send** to send the information to Searchpoint Optima Plus.
10. Return to the Welcome screen.

Note: If a value is sent which is outside the allowed range, it will be rejected. Searchpoint Optima Plus will offer the option to restore the previous value or re-enter another value.

12.4 Configure Device Identification Information

Searchpoint Optima Plus can hold information programmed by the user, such as an identification number (tag) or site specific details. Five text fields are available: -

- Description – up to 26 characters
- Assembly Date – mm/dd/yy
- Assembly Number – up to 8 characters
- Device Tag - up to 8 characters
- Transmitter ID – up to 32 characters

The fields for Description, Assembly Date and Assembly Number are undefined until they have been configured.

Note: Device Tag and Transmitter ID are commonly used by HART® hosts to identify individual devices (even when a handheld device is connected directly to the Searchpoint Optima Plus). These fields must not be left blank.

12. Commissioning using HART® Communications

1. Select **Device Setup**.
2. Select **Assembly Details**.
3. Select **Description**.
4. Enter required information up to 26 characters (for example the device type) and press **Enter**.
5. Select **Assembly Date**.
6. Enter required information in the format mm/dd/yy (for example the date of installation) and press **Enter**.
7. Select **Assembly Number**.
8. Enter required information up to 8 characters (for example a number related to the installation) and press **Enter**.
9. Select **Device Tag**.
10. Enter required information up to 8 characters (for example a unique device identification number) and press **Enter**.
11. Select **Transmitter ID**.
12. Enter required information up to 32 characters (for example the device location) and press **Enter**.
13. Press **Send** to send the information to Searchpoint Optima Plus.
14. Return to the Welcome screen.

12.5 Fix the 4-20 mA Output

The 4-20 mA output can be set to a fixed value between 1 mA and 21 mA, which can be used to calibrate the controller, or to test the system.

Note: This function will timeout after 10 minutes of inactivity.

Note: When connecting or disconnecting a multimeter, power off the Searchpoint Optima Plus, otherwise the unit will indicate a latched warning that the 4-20 mA loop was broken. If this occurs, it can be cleared using the HART® communications. See Clear Faults or Warnings.

1. Select **Device Setup**.
2. Select **Test**
3. Select **mA Loop Test**
4. The display shows a warning message, press **OK**.
5. Select required analogue output level and press **Enter**.

Searchpoint Optima Plus will now output the set mA value.

6. When ready, press **OK**
7. Repeat steps 4 and 5 with another value if required, or select **End**.
8. The display shows a note that the Searchpoint Optima Plus will return to normal operation, press **OK**.
9. The display shows a confirmation message, return to the Welcome screen.

12. Commissioning using HART® Communications

12.6 Test 4-20 mA Loop Integrity

It is recommended that the 4-20 mA loop integrity is tested by setting the Searchpoint Optima Plus to output an overrange current. This will confirm that there are no faults in the system that would cause a current limit.

Note: This function will timeout after 10 minutes of inactivity.

Note: When connecting or disconnecting a multimeter, power off the Searchpoint Optima Plus, otherwise the unit will indicate a latched warning that the 4-20 mA loop was broken. If this occurs, it can be cleared using the HART® communications. See Clear Faults or Warnings.

1. Select **Device Setup**.
2. Select **Test**
3. Select **mA Loop Test**
4. The display shows a warning message, press **OK**.
5. Select **Other**.
6. Input **21** and press **Enter**

Searchpoint Optima Plus will now output 21 mA.

7. Check that the signal at the controller is > 20 mA, then press **OK**
8. Select **End**.
9. The display shows a note that the Searchpoint Optima Plus will return to normal operation, press **OK**.
10. The display shows a confirmation message, return to the Welcome screen.

Note: If the current at the controller is not correct, check the 4-20 mA loop connections and cabling, and check that the loop resistance is less than 600 Ω. In current source mode, for supply voltages of 18 to 20 Vdc the maximum loop resistance is 500 Ω.

12.7 Calibrate the 4-20 mA Loop

If required, the 4 – 20 mA current output can be trimmed to match the controller. This is not a gas calibration.

Note: When connecting or disconnecting a multimeter, power off the Searchpoint Optima Plus, otherwise the unit will indicate a latched warning that the 4-20 mA loop was broken. If this occurs, it can be cleared using the HART® communications. See Clear Faults or Warnings.

Note: If this process is aborted at any time, it may be necessary to wait 10 minutes before attempting the calibration again. See Chapter 14, Troubleshooting.

12. Commissioning using HART® Communications

Note: Different time delays may be observed for low and high calibration.

1. Select **Device Setup**.
2. Select **Calibrate**.
3. Select **mA Loop Calibration**.
4. The display tells you to connect a reference meter, press **OK**.
5. The analogue output value will be set to 4 mA, press **OK** to confirm.
6. Enter the actual reading of the analogue output value (from reference meter or from the controller) and press **Enter**.

The Searchpoint Optima Plus will collect data and perform the low calibration.

7. When complete, the display shows a message that the unit is ready to perform the high calibration, press **OK**.
8. The analogue output value will be set to 20 mA, press **OK** to confirm.
9. Enter the actual reading of the analogue output value (from reference meter or from the controller) and press **Enter**.

The Searchpoint Optima Plus will collect data and perform the high calibration.

10. The display shows a confirmation message, press **OK**
11. The display shows a note that the Searchpoint Optima Plus will return to normal operation, press **OK**.
12. Return to the Welcome screen.

12.8 Configure Internal Alarm Threshold

The internal alarm threshold is used to log events when the gas reading exceeded the threshold. It is also used as the value to simulate Alarm. The default value is 20 %FSD.

1. Select **Device Setup**.
2. Select **Gas Configuration**.
3. Select **Alarm Threshold Configuration**.
4. Select **Alarm Threshold**.
5. Enter the new value between 10 %FSD and 65 %FSD, and press **Enter**.
6. Press **Send** to send the information to Searchpoint Optima Plus.
7. Return to the Welcome screen.

12.9 Simulation

Searchpoint Optima Plus can simulate Alarm, Fault and Warning conditions. This can be used to test the response of the overall system. Simulated Alarms, Faults and Warnings will not be recorded in the Event History.

12. Commissioning using HART® Communications

Note: HART During Fault must be configured to HART ACTIVE before simulating a Fault, to avoid losing communication with the Searchpoint Optima Plus. See Configure HART® Operation during Fault.

Note: When connecting or disconnecting a multimeter, power off the Searchpoint Optima Plus, otherwise the unit will indicate a latched warning that the 4-20 mA loop was broken. If this occurs, it can be cleared using the HART® communications. See Clear Faults or Warnings.

Note: This function will time out after 10 minutes of inactivity.

1. Select **Device Setup**.
2. Select **Test**.
3. Select **Simulate Alarm Fault**.
4. Select the required function to simulate and press **Enter**.

Searchpoint Optima Plus will output the appropriate mA value, and check for any errors.

5. If the simulation is successful, the display will show the message “No specific error”, press **OK**.
6. Repeat steps 4 and 5 to simulate different functions.
7. When test is complete select **End Simulation** and press **Enter**.
8. The display will show the message “No specific error”, press **OK**.
9. The display shows a note that the Searchpoint Optima Plus will return to normal operation, press **OK**.
10. Return to the Welcome screen.

12.10 Clear Faults or Warnings

During commissioning, faults or warnings may be generated. This will be indicated by the 4-20 mA output signal. Use the procedure below to clear them.

1. Select **Device Setup**.
2. Select **Unit Status**
3. Select **Active Faults** or **Active Warnings** to check for any faults or warnings.
4. Select **View**, then **First**, **Next** or **Previous** to display the fault or warning.

Note: First displays the active fault or warning that occurred earliest in time. “End of list” means that the last fault or warning has been reached.

5. Press **OK** and **Back** to return to the Unit Status menu.

Note: If no active faults or warnings are present, the 4-20 mA output signal may have latched due to an earlier fault or warning that has now cleared. Proceed to step 7 to clear latched faults or warnings.

6. Use the Problem Solving section of this manual to rectify the issue.
7. Press **Back** to return to the Device Setup menu.
8. Select **Test**.

12. Commissioning using HART® Communications

9. Select **Device Reset**.

10. Press **OK** to initiate a Device Reset, which will clear any latched faults or warnings.

Note: If any configuration changes have been made, wait 15 seconds before doing a soft reset or cycling the power.

11. The display shows a confirmation message. Press **OK**.

12. The display shows a note that the Searchpoint Optima Plus will return to normal operation, press **OK**.

13. Return to the Welcome screen.

13. Maintenance using HART® Communications

Read this chapter if HART® communications are being used to communicate with Searchpoint Optima Plus.

Note: The instructions that follow assume that a suitable HART® host (handheld or PC) is connected to the Searchpoint Optima Plus and that the user is logged in with Level 1 access privileges.

13.1 Introduction

This chapter explains how to perform common maintenance operations. Please refer to IEC/EN 60079-29-2 or other local or national regulations for guidance on establishing an appropriate maintenance routine.

Inspection	How to check and clean the unit
Inspection of a unit fitted with a Flow Housing	How to check and clean a unit fitted with a flow housing
Bump Test (Gas Challenge)	How to carry out a gas test using the Gassing Cover
Bump Test (Gas Challenge) with RGC	How to carry out a gas test using the Remote Gassing Cell (if fitted)
Re-zero Searchpoint Optima Plus	How to re-zero if gas test results are unacceptable
Calibration	How to calibrate the zero (and span if required)
Store Calibration Information	There is a text field available to the user to store useful information related to gas testing and calibration
Investigation of Faults or Warnings	How to view Faults and Warnings

Caution: After changing any parameter, poll the Searchpoint Optima Plus and verify that the received value is correct.

Note: When connecting or disconnecting a multimeter, power off the Searchpoint Optima Plus, otherwise the unit will indicate a latched warning that the 4-20 mA loop was broken. If this occurs, it can be cleared using the HART® communications. See Clear Faults or Warnings.

13.2 Inspection

Searchpoint Optima Plus should be inspected periodically and cleaned if necessary. The required frequency of inspection will depend on local site conditions and will need to be established through experience.

Caution: Gas readings may be generated during this procedure. Follow the steps to inhibit the 4-20 mA output. Ensure that the unit is not left in Inhibit mode.

1. Select **Device Setup**.
2. Select **Test**.
3. Select **Inhibit**.
4. Select **Start Inhibit** and press **Enter**.
5. The display shows a confirmation message. Press **OK**. The 4-20 mA output is now inhibited.
6. Inspect the Searchpoint Optima Plus unit, its junction box and cabling for any signs of physical damage.

13. Maintenance using HART® Communications

7. Using a ½ inch / 13 mm A/F open ended spanner, unscrew the two retaining nuts and remove the Standard Weather Protection.
8. Inspect the Standard Weather Protection for damage or build up of debris / contaminants. If required, clean or replace weather protection.
9. Inspect the Dust Barrier and clean or replace if required.
10. Remove the Dust Barrier and inspect the optics.
11. Clean any dust or contaminants from the optics using mild detergent and a soft cloth or cotton bud. Do not use solvents or abrasive cleaners.
12. Replace the Dust Barrier and Standard Weather Protection.
13. Select Device Reset to clear any faults or warnings that may have been generated by cleaning.
14. Press **OK** to initiate a Device Reset.

Note: If any configuration changes have been made, wait 15 seconds before doing a soft reset or cycling the power.

15. The display shows a confirmation message. Press **OK**.
16. The display shows a note that the Searchpoint Optima Plus will return to normal operation, press **OK**.
17. Select **Inhibit**.
18. Select **End Inhibit** and press **Enter**.
19. The display shows a confirmation message. Press **OK** to release the 4-20 mA output.
20. Return to the Welcome screen.

13.3 Inspection of a unit fitted with a Flow Housing

Searchpoint Optima Plus should be inspected periodically and cleaned if necessary. The required frequency of inspection will depend on local site conditions and will need to be established through experience.

Caution: Gas readings may be generated during this procedure. Follow the steps to inhibit the 4-20 mA output. Ensure that the unit is not left in Inhibit mode.

1. Select **Device Setup**.
2. Select **Test**.
3. Select **Inhibit**.
4. Select **Start Inhibit** and press **Enter**.
5. The display shows a confirmation message. Press **OK**. The 4-20 mA output is now inhibited.
6. Inspect the Searchpoint Optima Plus unit, its junction box and cabling for any signs of physical damage.
7. Disconnect any pipework attached to the flow housing.
8. Using a ½ inch / 13 mm A/F open ended spanner, remove the two black nuts which retain the flow housing. Keep the O-ring seals which are below the retaining nuts.
9. Slide the flow housing off the Searchpoint Optima Plus. This may require some force due to the friction of the O-ring.
10. Clean any dust or contaminants from the optics using mild detergent and a soft cloth or cotton bud. Do not use solvents or abrasive cleaners.

13. Maintenance using HART® Communications

11. Ensure that the large sealing O-ring in the body of the flow housing, and the two small O-rings which go below the retaining nuts, are clean and in good condition. Replace if in doubt.
12. Slide the flow housing over the end of the Searchpoint Optima Plus and push until the flow housing is firmly seated.
13. Re-fit the o-rings and retaining nuts.
14. Select **Device Reset** to clear any faults or warnings that may have been generated by cleaning.
15. Press **OK** to initiate a Device Reset.

Note: If any configuration changes have been made, wait 15 seconds before doing a soft reset or cycling the power.

16. The display shows a confirmation message. Press **OK**.
17. The display shows a note that the Searchpoint Optima Plus will return to normal operation, press **OK**.
18. Select **Inhibit**.
19. Select **End Inhibit** and press **Enter**.
20. The display shows a confirmation message. Press **OK** to release the 4-20 mA output.
21. Return to the Welcome screen.

13.4 Bump Test (Gas Challenge)

Searchpoint Optima Plus can be functionally checked using an appropriate test gas.

Caution: Gas readings will be generated during this procedure. The 4-20 mA output will be inhibited automatically. If the procedure is aborted, ensure that the unit is not left in Inhibit mode.

Note: The unit should be powered up for 1 hour before a gas test is done.

1. Select **Device Setup**.
2. Select **Calibrate**.
3. Select **Bump Test**.
4. Select **Start Bump Test** and press **Enter**.
5. The display shows a confirmation message, press **OK**. The 4-20 mA output is now inhibited.
6. Fit a Gassing Cover to the Searchpoint Optima Plus.
7. Apply an appropriate test gas at a rate of 1 – 1.5 litres per minute for ~ 30 - 60 s.
8. Check that the Searchpoint Optima Plus responds to the test gas. The live gas concentration is shown on the screen. The reading should be within ± 20 % of target. When ready to continue press **OK**.

Note: If the gas reading is not acceptable for the application, re-zero the Searchpoint Optima Plus and repeat the test. Factors to consider when evaluating the gas response include: -

- Test gas and concentration
- Tolerance of the test gas concentration
- Atmospheric pressure
- Ambient temperature
- Wind speed

13. Maintenance using HART® Communications

9. Remove the Gassing Cover and wait for the test gas to clear (~ 30 s). Ensure that the gas reading has returned to zero. Press **OK** to release the 4-20 mA output.
10. Return to the Welcome screen.

13.5 Bump Test (Gas Challenge) with Remote Gassing Cell (RGC)

Using a test gas of 50 %v/v methane in the Remote Gassing cell (RGC), a gas response will be generated from most Searchpoint Optima Plus units. The reading depends on the target gas calibration of the unit. The RGC is a tool to check for a gas response and is not precise; therefore variability in response between units should be expected.

Caution: Gas readings will be generated during this procedure. The 4-20 mA output will be inhibited automatically. If the procedure is aborted, ensure that the unit is not left in Inhibit mode.

Caution: Maximum flow rate is 0.3 litres per minute to avoid pressurising the gas in the RGC.

Note: This procedure only applies if the Searchpoint Optima Plus has a Remote Gassing Cell (RGC) fitted. The RGC is a factory fitted option.

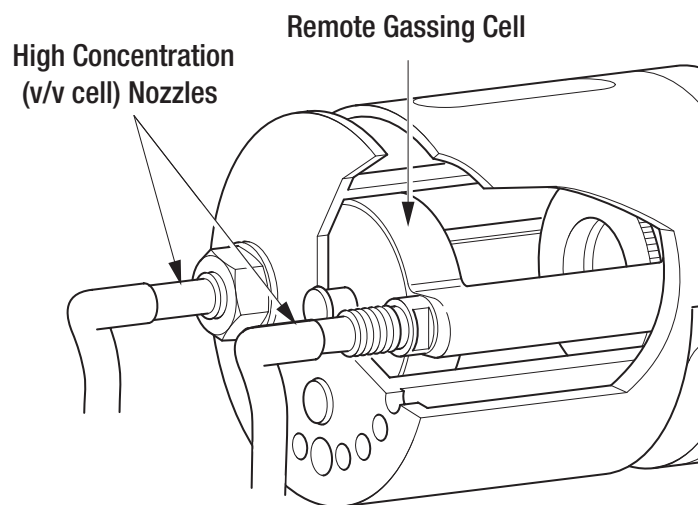

1. Inspect the gassing pipes to the RGC. Ensure that the exhaust is clear and vents well away from the Searchpoint Optima Plus, and does not cause a hazard.
2. Select **Device Setup**.
3. Select **Calibrate** then **Bump Test**.
4. Select **Start Bump Test** and press **Enter**.
5. The display shows a confirmation message, press **OK**. The 4-20 mA output is now inhibited.
6. Apply 50 %v/v methane at a rate of 0.3 litres per minute for ~ 30 - 60 s. (For long gas pipes > ~10 m, allow a longer time for the gas to reach Searchpoint Optima Plus).
7. Check that the Searchpoint Optima Plus responds to the test gas. The live gas concentration is shown on the screen. When ready to continue press **OK**.
8. Flush the RGC with zero gas until the gas reading has returned to zero. Press **OK** to release the 4-20 mA output.
9. Return to the Welcome screen.

13. Maintenance using HART® Communications

Note: If the gas reading is not acceptable for the application, re-zero the Searchpoint Optima Plus and repeat the test.

13.6 Re-zero Searchpoint Optima Plus

Re-zero Searchpoint Optima Plus if it has given an unexpected response to a gas test. In most cases a re-zero will restore accuracy and a full span calibration is not required.

Caution: During this procedure the 4-20 mA output will be inhibited automatically. If the procedure is aborted, ensure that the unit is not left in Inhibit mode.

1. Select **Device Setup**.
2. Select **Calibrate**.
3. Select **Gas Calibration**.
4. The display shows a warning message, press **OK**.
5. Ensure that there is zero gas present in the vicinity of the Searchpoint Optima Plus. If necessary, fit a Gassing Cover and apply zero gas.
6. When the gas reading on the display is stable press OK to initiate the Zero Calibration and then wait for approximately 15 s. The 4-20 mA output will be inhibited automatically at this time.
7. The display shows a message that the Zero Calibration was successful and offers to exit without a Span Calibration. Select **Yes** and press **Enter**.
8. The display shows a note that the Searchpoint Optima Plus will return to normal operation, press **OK**.
9. Return to the Welcome screen.

13.7 Calibration

Searchpoint Optima Plus is factory calibrated and does not require routine calibration. In most cases, a re-zero will correct any inaccuracy in the gas reading. It is strongly recommended that a span calibration is not carried out.

In the unlikely event that a span calibration is required, use a cylinder of the target gas, of approximately 50 %FSD, with an accuracy of at least $\pm 2\%$.

Note: Searchpoint Optima Plus will accept a span calibration gas concentration of between 30 %FSD and 125 %FSD, however this facility is reserved for use in specialist applications.

Do not calibrate Searchpoint Optima Plus during periods of very high or low atmospheric pressure, very strong winds or storms.

Caution: Gas readings will be generated during this procedure. The 4-20 mA output will be inhibited automatically. If the procedure is aborted, ensure that the unit is not left in Inhibit mode.

Note: The unit should be powered up for 1 hour before a calibration is done.

1. Using a ½ inch / 13 mm A/F open ended spanner, unscrew the two retaining nuts and remove the

13. Maintenance using HART® Communications

Standard Weather Protection from the Searchpoint Optima Plus.

2. Fit a Calibration Cap to the Searchpoint Optima Plus. Ensure it is pushed on fully.
3. Select **Device Setup**.
4. Select **Calibrate**.
5. Select **Gas Calibration**.
6. The display shows a warning message, press **OK**.
7. Ensure that there is zero gas present in the vicinity of the Searchpoint Optima Plus. If necessary, apply zero gas at a rate of 1 – 1.5 litres per minute.
8. When the gas reading on the display is stable press **OK** to initiate the Zero Calibration and then wait for approximately 15 s. The 4-20 mA output will be inhibited automatically at this time.
9. The display shows a message that the Zero Calibration was successful and offers to exit without a Span Calibration. Select **No** and press **Enter**.
10. Enter the concentration of the span calibration gas and press **Enter**.
11. Apply calibration gas at a rate of 1 – 1.5 litres per minute. Wait for the gas reading to stabilise (~ 30 - 60 s).
12. Press **OK** to initiate the Span Calibration and then wait for approximately 15 s.
13. The display shows a message that the Span Calibration was successful. Remove the Calibration Cap and wait for the test gas to clear (~ 30 s).
14. Ensure that the gas reading has returned to zero. Press **OK** to release the 4-20 mA output.
15. The display shows a note that the Searchpoint Optima Plus will return to normal operation, press **OK**.
16. Return to the Welcome screen.
17. Refit the Standard Weather Protection and the two retaining nuts.

13.8 Store Calibration Information

If required, information programmed by the user can be stored under the Calibrate menu in a text field called Calibration Info. For example, the date of the last bump test could be recorded.

1. Select **Device Setup**.
2. Select **Calibrate**.
3. Select **Calibration Info**.
4. Enter required information up to 32 characters and press **Enter**.
5. Press **Send** to send the information to Searchpoint Optima Plus.
6. Return to the Welcome screen.

13.9 Investigation of Faults or Warnings

13. Maintenance using HART® Communications

If the unit is signalling Fault or Warning on the 4-20 mA output, the problem should be investigated and remedied as soon as possible. Some types of faults and warnings will latch the 4-20 mA output and need to be cleared by a Reset.

1. Select **Device Setup**.
2. Select **Unit Status**
3. Select **Active Faults** or **Active Warnings** to check for any current faults or warnings.
4. Select **View**, then **First**, **Next** or **Previous** to display the fault or warning.

Note: First displays the fault or warning that occurred earliest in time.

5. Select **Back** then **Event History** to investigate a series of events in more detail.
6. Select **Filter**, then **Warnings** or **Faults** to display the events of interest.
7. Select **View**, then **Latest Log**, **Older Log** or **Newer Log** to navigate through the table of reported events.
8. Press **Back** to return to the Unit Status menu.
9. Use the Problem Solving section of this manual (Chapter 14) to rectify the issue.
10. Press **Back** to return to the Device Setup menu.
11. Select **Test**.
12. Select **Device Reset**.
13. Press **OK** to initiate a Device Reset, which will clear any latched faults or warnings.

Note: If any configuration changes have been made, wait 15 seconds before doing a soft reset or cycling the power.

14. The display shows a confirmation message. Press **OK**.
15. The display shows a note that the Searchpoint Optima Plus will return to normal operation, press **OK**.
16. Return to the Welcome screen.

14. Problem Solving

The Troubleshooting section explains how to deal with problems that may be encountered when using Searchpoint Optima Plus.

The Warnings and Faults section explains the meaning of diagnostic messages and the best course of action to deal with the problem.

Some types of faults and warnings will latch the 4-20 mA output and need to be cleared by a Reset.

Note: If any configuration changes have been made, wait 15 seconds before doing a soft reset or cycling the power.

Note: When connecting or disconnecting a multimeter, power off the Searchpoint Optima Plus, otherwise the unit will indicate a latched warning that the 4-20 mA loop was broken. If this occurs, it can be cleared using the SHC1 Handheld Interrogator or the HART® communications. See Clear Faults or Warnings.

Note: Searchpoint Optima Plus continues to function as a gas detector while indicating Warning, although aspects of its performance may be reduced.

If a problem persists please contact Honeywell Analytics for advice, using the contact details given on the back page.

14.1 Troubleshooting

Fault / Problem	Possible Cause	Remedial Action
No analogue output	Electrical installation problem	<ol style="list-style-type: none"> 1. Check that the +24 V supply is reaching the unit. Voltage at the unit should be between +18 V and +32 V. 2. Check cables and connections to the unit, especially the 4-20 mA loop connections
Output is < 1 mA or 1 mA	Unit is in Fault condition	<ol style="list-style-type: none"> 1. Connect the SHC1 Handheld Interrogator to the unit or use the HART® communications to ascertain the reason for the Fault report (see Maintenance). 2. Diagnose the problem using the table of Warning and Fault messages below.
Output is 2 ± 0.2 mA (or other configured Inhibit level)	Unit is in Inhibit	<ol style="list-style-type: none"> 1. The Inhibit mode has no time out. A procedure may have been aborted while the unit was in Inhibit. 2. Connect to the HART® communications and select Device Setup, Test, Inhibit then End Inhibit or Connect the SHC1 Handheld Interrogator and select Calibrate then Normal 4-20.
Output is 3 ± 0.2 mA (or other configured Warning level)	Unit is indicating a Warning Note: Unit will still function as a gas detector	<ol style="list-style-type: none"> 1. Connect the SHC1 Handheld Interrogator to the unit or use the HART® communications to ascertain the reason for the Warning report (see Maintenance). 2. Diagnose the problem using the table of Warning and Fault messages below.

14. Problem Solving

Unit does not respond as expected to test gas	Zero offset	1. Re-zero Searchpoint Optima Plus before repeating the test (see Maintenance, Bump Test).
	Dirty optics	1. Check that the optics are clean and dry. If necessary clean optics and carry out a soft reset (see Maintenance, Inspection).
	High or low atmospheric pressure	1. Searchpoint Optima Plus does not compensate for the effects of atmospheric pressure, which can change the gas reading (see Specification).
	Incorrect test gas	1. Check which gas and measuring range the Searchpoint Optima Plus is calibrated for. 2. Check that the correct test gas and concentration with an appropriate tolerance are being used. 3. Check that the gas cylinder is not empty. 4. Check that any gas tubing or inlet pipes are not broken or blocked. 5. Check that the correct flow rates and stabilisation times are being used (see Maintenance, Bump Test).
	Unit is in HART® multi-drop mode	1. A unit which is set to HART® multi-drop mode will output a constant 4 mA.
	Unit requires calibration	1. If all of the above checks have been done without correcting the problem, carry out a full calibration.
Output appears to be drifting	Correct response to low level gas concentration	1. Check the gas concentration where the Searchpoint Optima Plus is installed using a sensitive portable gas detector.
	Build-up of contamination on optics, e.g. oil mist, exhaust fumes, solvents etc.	1. Clean the Searchpoint Optima Plus and carry out a Reset (see Maintenance, Inspection). 2. If possible, identify and minimise potential sources of contamination. Contamination can be carried by steam.
Output appears to be unstable	Electrical interference being induced on 4-20 mA cabling	1. Check for earth loops. Confirm that the screen is earthed correctly (see Electrical Installation, Earth Regimes). 2. Look for noise on the signal using an oscilloscope. This may give some insight into the potential source. 3. For noisy installations, consider using filtering and signal processing at the control card.
	Poor contacts	1. Check the terminal connections in the junction box. 2. If necessary tighten the connectors. 3. Excessive vibration can loosen connections. If possible identify and minimise potential sources of vibration.

14. Problem Solving

Unit fails to respond to SHC1 Handheld Interrogator	Incorrect connection (may display Comms Error 100)	1. Check that the SHC1 Handheld Interrogator is correctly plugged into the DVC100 or that the SHC Protection device is connected correctly (see Use of the SHC1 Handheld Interrogator).
	Incorrect software	1. Searchpoint Optima Plus only works with SHC1 Handheld Interrogator software version 3v0 and above. Check software version. 2. If incorrect, contact Honeywell Analytics for the latest version of SHC1 Handheld Interrogator software.
	Incorrect mode (may display Comms Error 99)	1. Switch on the SHC1 Handheld Interrogator and check the display. It should show Optima+ (not Optima or Excel). 2. If incorrect, change the operating mode to Optima+ (see Use of the SHC1 Handheld Interrogator).
	Battery failed	1. Check the battery in the SHC1 Handheld Interrogator. 2. If necessary, replace the battery (see Use of the SHC1 Handheld Interrogator).
	Interference from HART® communication	The HART® communication takes precedence over the RS485 communication used by the SHC1 Handheld Interrogator. If the Searchpoint Optima Plus is being polled simultaneously by a HART® host, temporary communication errors may be experienced.
Unit fails to respond to HART® communications	HART® option not fitted	1. Check that the unit has the optional HART® communications fitted (part number ends in H)
	Incorrect Device Description file	1. Check that the correct Device Description file is loaded and selected.
	Problem with receiving the 4 – 20 mA signal	1. Check cables and connections to the unit, especially the 4-20 mA loop connections. 2. Check the 4 – 20 mA loop for noise
	Unit is in FAULT condition and the output is less than 1 mA	1. HART® communications will not function when the output current is less than 1 mA. 2. Configure the unit to output 1 mA when in Fault (see Commissioning, Configure HART® Operation during Fault) Note: It may be necessary to re-cycle the power to the unit, and change the setting during the 60 s warm up period while the unit is in Inhibit.
	HART® host is polling for a value that is not set	1. HART® hosts typically poll Device Address, Device Tag, Transmitter ID or Unique Device ID to locate a field device. 2. Change the setting to use Device Address (this is always set in the unit).

14. Problem Solving

Unit fails to respond to HART® handheld device	Incorrect connection	1. Check that the HART® handheld device is connected properly.
	Incorrect Device Description file	1. Check that the correct Device Description file is loaded and selected.
	HART® option not fitted	1. Check that the unit has the optional HART® communications fitted (part number ends in H)
	Battery failed	1. Check the battery in the HART® handheld device. 2. If necessary replace the battery (see manufacturer's instructions)
	Unit is in FAULT condition and the output is less than 1 mA	1. HART® communications will not function when the output current is less than 1 mA. 2. Configure the unit to output 1 mA when in Fault (see Commissioning, Configure HART® Operation during Fault) Note: It may be necessary to re-cycle the power to the unit, and change the setting during the 60 s warm up period while the unit is in Inhibit.
	HART® handheld device is polling for a value that is not set	1. HART® hosts typically poll Device Address, Device Tag, Transmitter ID or Unique Device ID to locate a field device. 2. Change the setting to use Device Address (this is always set in the unit).
4-20 mA Loop Calibration was aborted, now stuck in a timeout (HART® units)	There is a timeout of 10 minutes before the calibration can be re-started	1. To work around the timeout delay, select mA Loop Test from the Test menu. 2. Set the 4-20 mA to 4 mA. 3. Select End. 4. The mA Loop Calibration can now be re-started.
Password for Level 1 access has been lost (HART® units)	Some handheld devices hold a default password, which could be set in error	1. Re-start the handheld device. 2. From the Device Setup menu, select User Login and Level 1. 3. At the password entry screen, do not type anything, and press Enter immediately (use the default password from the handheld device). 4. If successful, select User Configuration and Change Password to set the password to a known value. 5. If the above was not successful, please contact Honeywell Analytics.

14. Problem Solving

14.2 WARNING and FAULT messages

SHC1	HART®	Meaning	Solution
W – Temp Lim Exceeded (error 0)	Warning Temperature Limit Exceeded	Specified operating temperature limits nearly exceeded.	<ol style="list-style-type: none"> 1. Protect the unit from heat / cold. 2. Re-locate the unit. 3. As an option consider installing the unit in a sampling system.
F – Temp Lim Exceeded (error 0)	Fault Temperature Limit Exceeded	Specified operating temperature limits exceeded.	<ol style="list-style-type: none"> 1. Remove the unit from service. Certification and warranty are invalidated.
W / F – Bad 24V Supply (error 4)	Warning / Fault Bad 24V Supply	24 V supply is outside of operating limits.	<ol style="list-style-type: none"> 1. Ensure that the supply voltage at the unit is between 18 V and 32 V. 2. Re-cycle the power or carry out a Reset to clear the latch. See Maintenance, View and Clear Faults or Warnings
W – Bad 4-20mA Loop (error 5) Note: this error will LATCH the 4-20 mA output	Warning Bad 4-20mA loop Note: this error will LATCH the 4-20 mA output	Error of greater than ± 0.5 mA in analogue output	<ol style="list-style-type: none"> 1. If this Warning occurred while connecting or disconnecting a multimeter, re-cycle the power or carry out a Reset to clear the latch. See Maintenance, View and Clear Faults or Warnings 2. Check the 4-20 mA loop connections and cabling 3. Check that the loop resistance is less than 600 Ω. In current source mode, for supply voltages of 18 to 20 Vdc the maximum loop resistance is 500 Ω.
F – Bad 4-20mA Loop (error 5) Note: this error will LATCH the 4-20 mA output	Fault Bad 4-20mA loop Note: this error will LATCH the 4-20 mA output	The unit cannot generate the correct current output to signal a gas reading (the unit reverts to Fault rather than under-reading)	<ol style="list-style-type: none"> 1. Check the 4-20 mA loop connections and cabling 2. Check that the loop resistance is less than 600 Ω. In current source mode, for supply voltages of 18 to 20 Vdc the maximum loop resistance is 500 Ω. 3. Re-cycle the power or carry out a Reset to clear the latch. See Maintenance, View and Clear Faults or Warnings
W / F – Neg Gas Reading (error 6)	Warning / Fault Negative gas reading	Negative offset on the gas reading.	<ol style="list-style-type: none"> 1. Check that the optics are clean and dry. If the unit is in an environment of very damp / condensing conditions, consider additional protection. 2. Check for the presence of interferent gases e.g. acetylene or ammonia. 3. Check for Temp Lim Exceeded warnings or faults. 4. Clean optics and ensure they are dry. Re-zero the unit provided the atmosphere is gas-free (see Maintenance, Inspection).

14. Problem Solving

W / F – Obscured Optics (error 8)	Warning / Fault Obscured optics	Contamination in the optical path.	<ol style="list-style-type: none"> 1. Remove the weather protection and dust barrier. Replace the dust barrier if required. 2. Clean optics and carry out a Soft Reset (see Maintenance, Inspection).
F – Signal Quality (error 16)	Fault Poor signal quality	Optical signal is low, noisy or unstable	<ol style="list-style-type: none"> 1. Remove the weather protection and dust barrier. Replace the dust barrier if required. 2. Clean optics and carry out a Soft Reset (see Maintenance, Inspection).
W / F – Lamp Output (error 11)	Warning / Fault Lamp output	Lamp signal is low.	<ol style="list-style-type: none"> 1. Clean optics and carry out a Soft Reset (see Maintenance, Inspection). 2. If the Fault / Warning does not clear, return unit for repair.
W / F – Internal Failure (error 22) Note: this error will LATCH the 4-20 mA output	Warning / Fault Hardware failure Note: this error will LATCH the 4-20 mA output	Internal hardware fault	<ol style="list-style-type: none"> 1. Cycle the power or carry out a Reset to restart the unit. See Maintenance, View and Clear Faults or Warnings 2. If the fault persists return the unit for repair.
F - Hardware Fault (error 13)	Fault Hardware Fault	The latched faults or warnings flag has been set	<ol style="list-style-type: none"> 1. This error may occur following Self Test. 2. Check for any active Faults or Warnings. 3. If none present, cycle the power or carry out a Reset to restart the unit. See Maintenance, View and Clear Faults or Warnings. 4. Repeat Self Test to confirm that the Fault has cleared. 5. If the Fault does not clear, return unit for repair.

14.3 Further Assistance

If the problem is still unresolved, please contact Honeywell Analytics technical support using the contact details on the back page of this manual.

Please have the following information to hand: -

- A description of the problem, including the steps taken to try to resolve it
- The serial number of the Searchpoint Optima Plus

For Searchpoint Optima Plus units with HART®, please also locate the following information by selecting Device Info from the Device Setup menu: -

- Dev id (unique Searchpoint Optima Plus identification number)
- Fld dev rev (revision number of the HART® DD file)
- Software rev (Searchpoint Optima Plus software revision number)
- Hardware rev (Searchpoint Optima Plus hardware revision number)

15. Specifications

15.1 Specifications

Environmental		
Operational and Certified Temperature Range*	- 40 °C to + 65 °C	
Pressure Range	80 to 120 kPa (non-compensated)	
Operating Humidity	0 to 99 %RH (non-condensing)	
Storage Conditions for Searchpoint Optima Plus and accessories	- 40 °C to + 65 °C, 80 to 120 kPa, 0 to 99 %RH (non-condensing)	
Ingress Protection	IP 66 / 67	
* CU-TR Ex (Russia) Approval – XTC Version Certified Temperature Range -60 °C to + 65 °C		
Performance		
Repeatability	< ± 2 %FSD at 50 %FSD	
Linearity	< ± 5 %FSD	
Accuracy	Baseline < ± 1 %FSD (Ethylene < ± 2 %FSD) 50 %FSD < ± 2 %FSD (Ethylene < ± 3 %FSD)	
Long Term Stability (as defined in EN 60079-29-1)	Baseline	Methane 100 %LEL Range: ≤ ± 2 %FSD Ethylene 100 %LEL Range: ≤ ± 4 %FSD
	50 %FSD	Methane 100 %LEL Range: ≤ ± 4 %FSD Ethylene 100 %LEL Range: ≤ ± 5 %FSD
Drift Over Temperature Range (-40 °C to 65 °C)	Baseline	≤ ± 2 %FSD
	50 %FSD	Methane 100 %LEL Range: ≤ ± 0.131 %FSD per °C Ethylene 100 %LEL Range: ≤ ± 0.078 %FSD per °C
Pressure Coefficient	1 % of reading per kPa	
Response Time		
Response Time	Complies with EN60079-29-1 (ATEX Performance Standard) T50 < 3 seconds, T90 < 4 seconds (for methane, no accessories) T50 = 6 seconds, T90 = 18 seconds (for methane, as supplied, fitted with Standard Weather Protection and Dust Filter)	
Note: For gas calibrations other than the standard hydrocarbon gases (methane, ethane, propane, butane), the response time may be slower than specified.		
Operation		
Power Supply	18 to 32 Vdc (24 Vdc nominal)	
Power Consumption	< 5 W	
Maximum 4-20 mA Loop Resistance	600 Ω	
Minimum 4-20 mA Loop Resistance to maintain HART® communications	230 Ω	
Retention of battery backed up data*	3 years unpowered	
4-20 mA Output Refresh Rate	250 ms	
Note: In current source mode, for supply voltages of 18 to 20 Vdc the maximum loop resistance is 500 Ω.		
* Searchpoint Optima Plus contains a backup battery which maintains the real time clock and event logs		

15. Specifications

Output Signals	
Measuring Range	4-20 mA (0-100 %FSD), auto sensing sink or source
Inhibit	1 to 3 mA (Default 2 mA)
Warning	0 to 6 mA (Default 3 mA*)
Fault	< 1 mA
Overrange	20 to 21.6 mA (Default 21 mA)
*Note: For ATEX compliance the Warning value should not be set > 3 and < 5 mA.	
Digital Outputs	HART® over 4-20 mA Proprietary RS485 communications
Dimensions	
Length	165 mm
Diameter	73 mm
Weight	1.6 kg
Material	316 stainless steel
Compliance to Standards	
Please refer to the EC Declaration of Conformity	
SHC1 Handheld Interrogator	
Operating Temperature Range	0 °C to +40 °C
Certified Temperature Range	-40 °C to +40 °C
Storage Temperature Range	-10 °C to +40 °C
Operating and Storage Humidity	0 to 99% RH
Dimensions	190 mm x 80 mm x 40 mm (L x W x D)
Weight	0.5 kg
Material	316 stainless steel

15.2 Available Gas Calibrations

CAUTION: For Special Gas Tables the ATEX Performance Approval only applies when Searchpoint Optima Plus is calibrated using the target gas or vapour.

* **NOTE:** for instruments manufactured in the Russian Federation, calibration is available only for these gases: methane, ethane, propane, butane, ethylene.

15.2.1 Hydrocarbon version of Searchpoint Optima Plus

Calibrated against EN50054 LEL levels					
Table Number	Table Name	CAS Number	Full Scale	LEL (%V/V)	ATEX Performance Approved
Standard Gases					
D3001	Methane	74-82-8	100%LEL	5	Y
D3002	Ethane	74-84-0	100%LEL	3	

15. Specifications

D3004	Propane	74-98-6	100%LEL	2	Y
D3005	Butane	106-97-8	100%LEL	1.5	Y
Special Gases					
D3006	Propene	115-07-1	100%LEL	2	
D3012	Acetone	67-64-1	100%LEL	2.15	
D3018	Butan-1-ol	71-36-3	100%LEL	1.4	
D3020	Butyl acetate	123-86-4	100%LEL	1.2	
D3022	Butanone	78-93-3	100%LEL	1.8	
D3024	Cyclohexane	110-82-7	100%LEL	1.2	
D3026	Cyclohexanone	108-94-1	100%LEL	1.3	
D3028	Ethanol	64-17-5	100%LEL	3.3	
D3030	Ethyl acetate	141-78-6	100%LEL	2.1	
D3032	Heptane	142-82-5	100%LEL	1.1	
D3034	Hexane	110-54-3	100%LEL	1.2	
D3040	Methanol	67-56-1	100%LEL	5.5	
D3042	Toluene	108-88-3	100%LEL	1.2	
D3044	o-Xylene	95-47-6	100%LEL	1	
D3048	Diethyl ether	60-29-7	100%LEL	1.7	
D3054	p-Xylene	106-42-3	100%LEL	1	
D3056	Pentane	109-66-0	100%LEL	1.4	
D3059	Dimethyl ether	115-10-6	100%LEL	3	
D3064	N,N-Dimethyl formamide(DMF)	68-12-2	100%LEL	2.2	
D3073	Propane	74-98-6	100%LEL	2.0	Y

Calibrated against EN60079-20-1:2010 LEL levels					
Table Number	Table Name	CAS Number	Full Scale	LEL (%V/V)	ATEX Performance Approved
Standard Gases					
D3170	Methane	74-82-8	100%LEL	4.4	Y
D3172	Propane	74-98-6	100%LEL	1.7	Y
D3173	Butane	106-97-8	100%LEL	1.4	Y
Special Gases					
D3013	Acetone	67-64-1	100%LEL	2.5	Y
D3021	Butyl acetate	123-86-4	100%LEL	1.3	Y
D3029	Ethanol	64-17-5	100%LEL	3.1	Y
D3035	Hexane	110-54-3	100%LEL	1	Y
D3037	Propan-2-ol	67-63-0	100%LEL	2	Y
D3045	o-Xylene	95-47-6	100%LEL	1	Y
D3062	Octane	111-65-9	100%LEL	0.8	
D3070	Isobutane	75-28-5	100%LEL	1.3	

15. Specifications

D3084	Chloroethane	75-00-3	100%LEL	3.6	
D3090	1,2-Dichloroethane	107-06-2	100%LEL	6.2	Y
D3098	Dimethyl ether	115-10-6	100%LEL	2.7	Y
D3174	Propene	115-07-1	100%LEL	2	Y

Calibrated against EN61779 LEL levels					
Table Number	Table Name	CAS Number	Full Scale	LEL (%V/V)	ATEX Performance Approved
Standard Gases					
D3171	Ethane	74-84-0	100%LEL	2.5	
Special Gases					
D3019	Butan-1-ol	71-36-3	100%LEL	1.7	Y
D3023	Butanone	78-93-3	100%LEL	1.8	Y
D3025	Cyclohexane	110-82-7	100%LEL	1.2	
D3027	Cyclohexanone	108-94-1	100%LEL	1	Y
D3031	Ethyl acetate	141-78-6	100%LEL	2.2	Y
D3033	Heptane	142-82-5	100%LEL	1.1	Y
D3039	Propyl acetate	109-60-4	100%LEL	1.7	
D3041	Methanol	67-56-1	100%LEL	5.5	Y
D3043	Toluene	108-88-3	100%LEL	1.1	Y
D3049	Diethyl ether	60-29-7	100%LEL	1.7	
D3055	p-Xylene	106-42-3	100%LEL	1	Y
D3056	Pentane	109-66-0	100%LEL	1.4	
D3078	i-Propyl Acetate	108-21-4	100%LEL	1.8	
D3085	Propan-1-ol	71-23-8	100%LEL	2.2	

Additional ranges offered					
Table Number	Table Name	CAS Number	Full Scale	LEL (%V/V)	ATEX Performance Approved
Special Gases					
D3017	Hexamethyldisiloxane (HMDS)	107-46-0	100%LEL	1.3	
D3036	Propan-2-ol	67-63-0	100%LEL	2	
D3038	Propyl acetate	109-60-4	100%LEL	1.8	
D3047	Benzin60/95	Mixture	100%LEL	1	Y
D3050	Methane V/V	74-82-8	100%V/V	NA	
D3058	AVTUR JP8	Mixture	100%LEL	0.8	
D3060	Decamethyltetrasiloxane (DCMTS)	141-62-8	100%LEL	0.9	
D3061	Octane	111-65-9	100%LEL	1	
D3063	Octamethyltrisiloxane (OMTS)	107-51-7	100%LEL	0.9	
D3067	JP1	Mixture	100%LEL	0.6	

15. Specifications

D3068	Methyl isobutyl Ketone (MIBK)	108-10-1	100%LEL	1.4	
D3069	Isobutane	75-28-5	100%LEL	1.8	
D3077	1-Pentene	109-67-1	100%LEL	1.4	
D3081	1-Octene	111-66-0	100%LEL	0.7	
D3083	1-Hexene	592-41-6	100%LEL	1.2	
D3087	Methane 100k	74-82-8	100k ppm	NA	
D3088	Ethylene 100k	74-85-1	100k ppm	NA	
D3089	Propane 100k	74-98-6	100k ppm	NA	
D3092	Propene 50k	115-07-1	50k ppm	NA	
D3093	1-Methoxy-2-Propanol	107-98-2	100%LEL	1.8	Y
D3094	3-Ethoxy-1-Propanol	111-35-3	100%LEL	1.3	
D3095	Benzin 80/110	Mixture	100%LEL	0.9	Y
D3096	Propane 10k	74-98-6	10k ppm	NA	Y
D3097	Propane 5k	74-98-6	5k ppm	NA	Y
D3100	Propane 400k	74-98-6	400k ppm	NA	
D3101	Propylene Glycol Methyl Ether Acetate (PGMEA)	108-65-6	100%LEL	1.3	
D3102	Propane 600k	74-98-6	600k ppm	NA	
D3105	Propane 20k	74-98-6	20k ppm	NA	
D3107	Butane 18k	106-97-8	18k ppm	NA	
D3108	Methyl isoamyl Ketone (MIAK)	110-12-3	100%LEL	1.3	
D3111	1-Ethoxy-2-Propanol	1569-02-4	100%LEL	1.3	Y
D3150	Band A	n/a	100%LEL	NA	
D3151	Band B	n/a	100%LEL	NA	
D3152	Band C	n/a	100%LEL	NA	
D3153	Band D	n/a	100%LEL	NA	
D3175	Propane 5k	74-98-6	5k ppm	NA	Y

15.2.2 Ethylene version of Searchpoint Optima Plus

Calibrated against EN50054 LEL levels					
Table Number	Table Name	CAS Number	Full Scale	LEL (%V/V)	ATEX Performance Approved
Standard Gases					
D3225	Ethylene	74-85-1	100%LEL	2.7	Y
Special Gases					
D3227	Benzene	71-43-2	100%LEL	1.2	
D3228	Styrene	100-42-5	100%LEL	1.1	
D3229	Buta-1,3-diene	106-99-0	100%LEL	1.4	

15. Specifications

Calibrated against EN60079-20-1:2010 LEL levels					
Table Number	Table Name	CAS Number	Full Scale	LEL (%V/V)	ATEX Performance Approved
Standard Gases					
D3240	Ethylene	74-85-1	100%LEL	2.3	Y
Special Gases					
D3227	Benzene	71-43-2	100%LEL	1.2	
D3229	Buta-1,3-diene	106-99-0	100%LEL	1.4	

Calibrated against EN61779 LEL levels					
Table Number	Table Name	CAS Number	Full Scale	LEL (%V/V)	ATEX Performance Approved
Standard Gases					
D3228	Styrene	100-42-5	100%LEL	1.1	

Note: For other gases, solvents and vapours, contact Honeywell Analytics.

Note: The choice of LEL value should be in accordance with local regulations.

15.3 Cross Interference to Other Gases and Vapours

Searchpoint Optima Plus is supplied pre-calibrated and ready for installation. The signal output configuration, gas and range for which the unit is calibrated are indicated on a label attached to the main housing.

Note: The following information is only applicable when detecting Hydrocarbons.

A Searchpoint Optima Plus calibrated for a particular hydrocarbon will have a response to most other hydrocarbon gases. The cross-sensitivity figures below are approximate and are for guidance only.

The approximate amount of gas required to give an output equal to 50% LEL methane, on Searchpoint Optima Plus calibrated for 100% LEL (LEL = 5 %v/v) methane is: -

Methane	2.5 %v/v
Propane	0.3 %v/v
Butane	0.2 %v/v
Hexane	0.3 %v/v
Heptane	0.3 %v/v
Propylene	0.8 %v/v

The following gases are known to produce a negative response from Searchpoint Optima Plus: -

- Ammonia
- Acetylene
- Propyne (Methyl Acetylene)

As a guide, the approximate concentrations that will create a Fault condition in a Searchpoint Optima Plus calibrated for methane are: -

Ammonia	~ 5500 ppm
Acetylene	~ 1000 ppm
Propyne (Methyl Acetylene)	~ 1000 ppm

16. Ordering Information

Part Number	Description
Searchpoint Optima Plus: (add H to part number for HART® option, e.g. 2108N4000H, add N to part number for non-HART® option, e.g. 2108N4000N)	
Certified	ATEX/IECEX
2108N4000	Hydrocarbon calibration, with dust barrier, weather housing, deluge/heat shade
2108N4001	Ethylene calibration, with dust barrier, weather housing, deluge/heat shade
2108N4010	Hydrocarbon calibration, with dust barrier, weather housing, deluge/heat shade including remote gassing cell
2108N4011	Ethylene calibration with dust barrier, weather housing, deluge/heat shade including remote gassing cell
2108N5000	Hydrocarbon calibration, for use in remote sampling systems complete with flow housing
2108N5001	Ethylene calibration, for use in remote sampling systems complete with flow housing
2108N5010	Hydrocarbon calibration, for use in remote sampling systems for gas ranges 0–100 %v/v methane, 0–600,000 ppm propane and 0–400,000 ppm propane, fitted with remote gassing cell and flow housing
Certified	UL/Inmetro
2108N4100	Hydrocarbon calibration, with dust barrier, weather housing, deluge/heat shade
2108N4101	Ethylene calibration, with dust barrier, weather housing, deluge/heat shade
2108N4110	Hydrocarbon calibration, with dust barrier, weather housing, deluge/heat shade including remote gassing cell
2108N4111	Ethylene calibration with dust barrier, weather housing, deluge/heat shade including remote gassing cell
2108N5100	Hydrocarbon calibration, for use in remote sampling systems, includes flow housing
2108N5101	Ethylene calibration, for use in remote sampling systems, includes flow housing
2108N5110	Hydrocarbon calibration, for use in remote sampling systems for gas ranges 0–100 %v/v methane, 0–600,000 ppm propane and 0–400,000 ppm propane, fitted with remote gassing cell and flow housing
Certified	FM/CSA
2108N4200	Hydrocarbon calibration, with dust barrier, weather housing, deluge/heat shade
2108N4210	Hydrocarbon calibration, with dust barrier, weather housing, deluge/heat shade including remote gassing cell
2108N5200	Hydrocarbon calibration, for use in remote sampling systems, includes flow housing
Certified	CCCF (Chinese)
2108N4600	Hydrocarbon calibration, with dust barrier, weather housing, deluge/heat shade
2108N4601	Ethylene calibration, with dust barrier, weather housing, deluge/heat shade
2108N4610	Hydrocarbon calibration, with dust barrier, weather housing, deluge/heat shade, including remote gassing cell
2108N4611	Ethylene calibration with dust barrier, weather housing, deluge/heat shade, including remote gassing cell
2108N5600	Hydrocarbon calibration, for use in remote sampling systems complete with flow housing
2108N5601	Ethylene calibration, for use in remote sampling systems complete with flow housing

16. Ordering Information

Marine Approved	
2108N4400	Hydrocarbon calibration, with dust barrier, weather housing, deluge/heat shade
2108N4401	Ethylene calibration, with dust barrier, weather housing, deluge/heat shade
2108N4410	Hydrocarbon calibration, with dust barrier, weather housing, deluge/heat shade, including remote gassing cell
2108N4411	Ethylene calibration with dust barrier, weather housing, deluge/heat shade, including remote gassing cell
2108N5400	Hydrocarbon calibration, for use in remote sampling systems complete with flow housing
2108N5401	Ethylene calibration, for use in remote sampling systems complete with flow housing
2108N5410	Hydrocarbon calibration, for use in remote sampling systems for gas ranges 0–100 %v/v methane, 0–600,000 ppm propane and 0–400,000 ppm propane, fitted with remote gassing cell and flow housing
Certified - Searchpoint Optima XTC – Eurasian Customs Union and Pattern Approval	
2108N4800	Hydrocarbon calibration, with dust barrier, weather housing, deluge/heat shade
2108N4801	Ethylene calibration, with dust barrier, weather housing, deluge/heat shade
2108N4810	Hydrocarbon calibration, with dust barrier, weather housing, deluge/heat shade including remote gassing cell
2108N4811	Ethylene calibration with dust barrier, weather housing, deluge/heat shade including remote gassing cell
2108N5800	Hydrocarbon calibration, for use in remote sampling systems complete with flow housing
2108N5801	Ethylene calibration, for use in remote sampling systems complete with flow housing
Spares: (add H to part number for HART® option, add N to part number for non-HART® option)	
2108B2001	Hydrocarbon Optima Plus, ATEX/IECEx
2108B2003	Ethylene Optima Plus, ATEX/IECEx
2108B2101	Hydrocarbon Optima Plus, UL /Inmetro
2108B2103	Ethylene Optima Plus, UL /Inmetro
2108B2201	Hydrocarbon Optima Plus, FM/CSA
2108B2031	Hydrocarbon Searchpoint Optima Plus, CCCF (Chinese)
2108B2033	Ethylene Searchpoint Optima Plus, CCCF (Chinese)
2108B2051	Hydrocarbon Optima Plus, Marine Approved
2108B2053	Ethylene Optima Plus, Marine Approved
2108B2041	Hydrocarbon Optima Plus XTC, Customs Union and Russian Pattern Approval
2108B2043	Ethylene Optima Plus XTC, Customs Union and Russian Pattern Approval
Weather Protection Accessories	
2108B0276	Standard Weather Protection
2108D0275	Deluge / Heat Shade
2108B0280	Storm Baffle (ATEX)
2108B0259	Dust Barrier

16. Ordering Information

Gassing Accessories	
2108D0258	Gassing Cover
2108B0272	Calibration Cap
2108B0282	Flow Housing
Mounting Accessories	
04200-A-1040	Junction Box Adaptor Plate
2308B0930	HALO Retrofit Adaptor Plate Kit
2308B0923	HALO Pipe Mounting Bracket Kit
2308B0934	HALO Sunshade Kit
2104B0349	European Duct Mounting Kit – Metric Threads
04200-A-1015	Honeywell Analytics Junction Box Duct Mounting Kit
2442-0016	US Duct Mounting Kit – NPT Threads
Termination Units	
2308B0900	HALO junction box with HART® connection
2308B0903	HALO junction box
2104B6211	DVC100(I) MK2 Termination Unit ATEX / IECEx
2104B6212	DVC100(M) MK2 Termination Unit ATEX / IECEx with MODBUS capability
00780-A-0100	Term Hsg-Bartec DE1155 With Continuity Plate 1x25mm- 3x20mm Entries (ATEX certified)
2441-0022	6 wire Junction Box (UL certified)
Commissioning and Maintenance Accessories	
04230-A-1001	SHC1 Handheld Interrogator ATEX / IECEx Certified (4V0 software) for Optima, Optima Plus and Excel
2104B2351	SHC1 Handheld Interrogator UL Certified (4V0 software) for Optima, Optima Plus and Excel
2104B2354	SHC1 Handheld Interrogator CSA Certified (4V1 software) for Optima, Optima Plus and Excel
04230-A-1025	SHC Protection Device module and lead
2104B6250	SHC Calibrator Connector System 10m
2108B1455	SHC1 Handheld Interrogator EEPROM upgrade (4V0)
TBA	Spare set of O-rings for Flow Housing
Manuals (Hard Copy)	
2108M0550	Searchpoint Optima Plus Operating Instructions (English)

Additional copies of this manual, in English and various other languages, may be downloaded from our website. Navigate to www.honeywellanalytics.com and select Technical Services & Support, then Technical Library.

17. Warranty Summary

Honeywell Analytics warrants the Searchpoint Optima Plus against defective parts and workmanship and will repair or (at its option) replace any instruments which are or may become defective under proper use within 36 months from date of shipment from Honeywell Analytics.

This warranty does not cover consumable items, normal wear and tear or damage caused by accident, abuse, improper installation, poisons, contaminants or abnormal operating conditions. Under no circumstances shall Honeywell Analytics liability exceed the original purchase price paid by the buyer for the product.

Any claim under the Honeywell Analytics Product Warranty must be made within the warranty period and as soon as reasonably possible after a defect is discovered. In the event of a warranty claim please contact your local Honeywell Analytics Service representative.

This is a summary, for full warranty terms please refer to the Honeywell Analytics “General Statement of Limited Product Warranty” available upon request.

18. Certification and Approvals

18.1 EC Declaration of Conformity

A full EC declaration of conformity is available on the CD accompanying the product. This document lists the European Standards with which the Searchpoint Optima Plus complies.

18.2 Hazardous Area Certification

18.2.1 ATEX

Certificate Number: Baseefa 13ATEX0296X
Ⓔ II 2 GD Ex d op is IIC Gb Ex tb IIIC Db
T96°C (Tamb -40°C to +65°C)
T86°C (Tamb -40°C to +55°C)
IP 66/67
Vmax=32Vdc Pmax=8W

18.2.2 UL

File Number: E91044 – Vol. 1
Class I, Groups B, C and D
(Amb -40°C to +65°C)
Vmax=32Vdc Pmax=8W

18.2.3 InMetro (Brazil)

Certificate Number: TÜV 12.1017 X
BR-Ex d IIC T5 IP66/67 (-40 °C ≤ Ta ≤ +55 °C)
BR-Ex d IIC T4 IP66/67 (-40 °C ≤ Ta ≤ +65 °C)
Umax = 32 Vcc
Pmax = 8 W

18.2.4 CSA

Certificate number: 1139164
Class I, Div 1, Groups B, C and D Tamb -40°C to +65°C
Vmax=32Vdc Pmax=8W

18.2.5 FM

Certificate number: 3015165
Class I, Division 1, Groups B, C and D

18.2.6 CU-TR Ex (Eurasian) Approval – XTC Version (Russia)

Certificate number: TC RU C-US.ГБ08.B.01294

№ TC RU C-US.ГБ08.B.01294 (Made in Great Britain)
№ TC RU C-RU.ГБ08.B.01692 (Made in Russia)
1Ex db op isb IIC T86°C/T96°C X,
Ex tb IIIC T86°C/T96°C X
(Tamb -60°C до +65°C)

18. Certification and Approvals

18.2.7 CCCF (China)

Certificate Number: CE031155
Ex d IIC T4/T5

18.2.8 IECEX

Certificate Number: BAS 13.0069X

18.3 Performance Approvals

18.3.1 ATEX

Certificate Number: BVS 03 ATEX G 016 X

Special conditions for safe use

The following special properties have to be considered at operation of the remote sensor:

- See EC-type examination certificate Baseefa 13ATEX0296X
- The parameter “warning” shall not be set to values between 3 mA and 5 mA
- Searchpoint Optima Plus shall be calibrated using the target gas or vapour
- The Modbus-interface is not subject of this supplement to the EC-type examination certificate
- The HART-interface is included in this supplement to the EC-type examination certificate with respect to the use for configuration, commissioning, test and maintenance of the remote sensor
- Do not use the light ring indication of the junction box HALO for safety related purposes

18.3.2 FM

Certificate number: 3015165

This Approval does not include or imply Approval of apparatus to which the subject instrumentation may be connected. In order to maintain an FM Approved system, the apparatus to which this instrument is connected must also be Approved by FM Approvals.

As part of this Approval, it was verified that optional communication functions of this gas detection instrument while operating at the maximum transaction rate do not adversely affect the gas detection operation and functions of the instrument. This Approval, however, does not include or imply Approval of the communications protocol or functions provided by the software of this instrument or of the communications apparatus or software connected to this instrument.

18. Certification and Approvals

18.3.3 Russian Pattern Approval (Metrology) - XTC Version

NOTE: For instruments manufactured in the Russian Federation, calibration is available only for these gases: methane, ethane, propane, butane, ethylene.

This approval covers the following gases:

as Name	Measuring Range (%LEL)	Measuring Range (expressed in %v/v)
Methane	0 to 100	0 to 4.4
Ethane	0 to 100	0 to 2.5
Propane	0 to 100	0 to 1.7
Butane	0 to 100	0 to 1.4
Heptane	0 to 100	0 to 1.1
Hexane	0 to 100	0 to 1.0
Methanol	0 to 50	0 to 3.75
Toluene	0 to 100	0 to 1.1
o-Xylene	0 to 20	0 to 0.2
p-Xylene	0 to 18	0 to 0.2
Pentanes	0 to 100	0 to 1.4
Octane	0 to 50	0 to 0.4
Butadiene	0 to 100	0 to 1.4
Isobutane	0 to 100	0 to 1.3
Methane	-	0 to 100
Ethylene	0 to 100	0 to 2.3
Propylene	0 to 100	0 to 2.00
Benzene	0 to 100	0 to 1.2
Sterol	0 to 27	0 to 0.3

Please refer to the Metrology certificate for Searchpoint Optima XTC for full details.

18.4 Marine Approvals

Searchpoint Optima Plus complies with the EC Marine Equipment Directive (MED).



0062/XX

Note: XX represents the year of manufacture

Type Approvals: Bureau Veritas
American Bureau of Shipping
Det Norsk Veritas
Lloyd's Register

18. Certification and Approvals

18.5 SHC1 Handheld Interrogator Hazardous Area Certification

18.5.1 ATEX

Certificate Number: Baseefa 03 ATEX 0073
 Ⓜ II 2 G Ex ia IIC T4 Gb
 (Tamb. -40°C to +40°C)

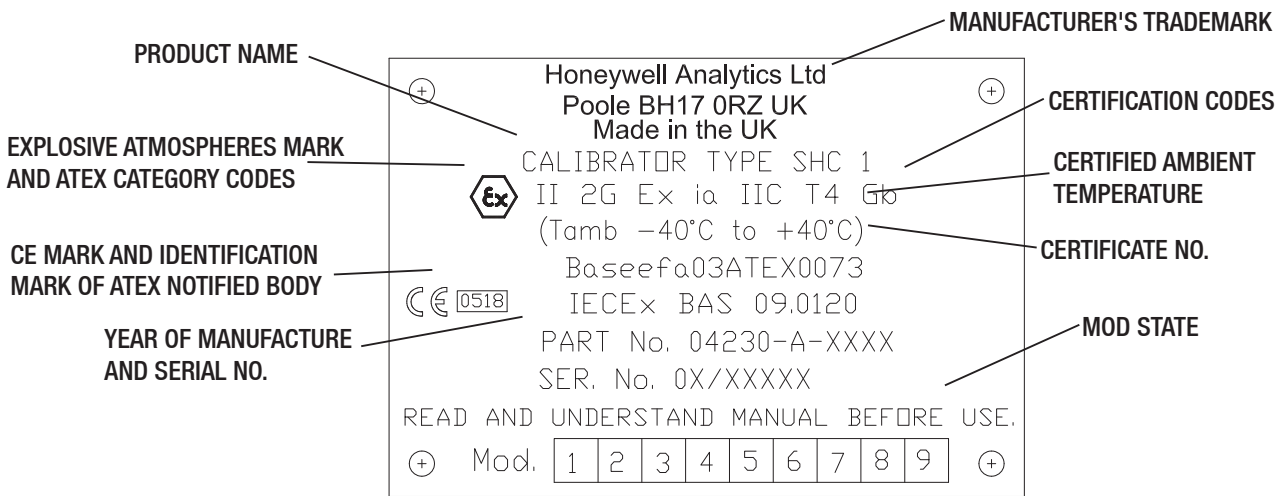

18.5.2 IECEX

Certificate Number: BAS 09.0120

Note: The instructions that follow assume that the SHC1 is switched on, in Optima+ mode, in the Main Menu. See Chapter 8 "Use of the SHC1 Handheld Interrogator" for details.

Caution: After changing any parameter, poll the Searchpoint Optima Plus and verify that the received value is correct.

19. Appendix 1 – SHC1 Additional Functions

19.1 Changing the Target Gas

Searchpoint Optima Plus is supplied with look-up tables for several different gases. If required, the gas table can be changed to a different target gas.

WARNING

If a new gas table is selected, the Searchpoint Optima Plus **MUST** be re-calibrated using the target gas.

Searchpoint Optima Plus stores a number of gas tables up to a maximum of 10. These include the Standard Gases (Methane, Ethane, Propane, Butane for Hydrocarbon units, Ethylene for Ethylene units) plus any Special Gases that have been specified when the unit was ordered. (For a full list of gases available to order please see Specification).

Caution: Searchpoint Optima Plus units contain a gas table called Linear 20R which is a factory setting. DO NOT select this gas table.

1. Select **Gas Tables** then **Show Library** to view the gas tables available for the unit.
2. Press **Escape**.
3. Select **Select Gas**.
4. Scroll through the available options to find the gas required.
5. Press **Enter**.
6. Display will read "**Gas Selection OK**"
7. Press **Enter** to release the 4-20mA output
8. Press **Escape** to return to the main menu.
9. Using a ½ inch / 13 mm A/F open ended spanner, unscrew the two retaining nuts and remove the Standard Weather Protection.
10. Fit a Calibration Cap to the Searchpoint Optima Plus. Ensure it is pushed on fully.
11. Select **Calibrate** then **CalSensor**. (This will inhibit the 4-20 mA output signal).
12. Ensure that there is zero gas present in the vicinity of the Searchpoint Optima Plus. If necessary, apply zero gas at a rate of 1 – 1.5 litres per minute.
13. Press **Enter**.

When the process is complete the display will state **Zero Calibrated**. It will then show options to continue to a span calibration, or to exit calibration.

14. Press **Enter** to begin span calibration.
15. Press **Enter**.
16. Use ▲ and ▼ to set the concentration of the calibration gas. When it is correct, press **Enter**.
17. Apply test gas at a rate of 1 – 1.5 litres per minute. Wait for the gas reading to stabilise (~ 30 - 60 s).
18. Press **Enter**.

When the process is complete the display will show Span Calibrated. It will then show an instruction to remove gas.

19. Remove the Calibration Cap and wait for the test gas to clear (~ 30 s). Ensure that the gas reading has returned to zero.
20. Press **Enter**.
21. Refit the Standard Weather Protection and the two retaining nuts.
22. Press **Enter** to release the 4-20 mA output signal.
23. Press **Escape** to return to the main menu.

19. Appendix 1 – SHC1 Additional Functions

19.2 Self Test

If there are any latched faults or warnings set in the unit, Self Test will report the generic error code “Hardware Fault Error 13”. Carry out a Soft Reset to clear the latches and remove this error.

1. Select **Diagnose** then **Soft Reset**.
2. Press **Escape** to return to the main menu.

20. Appendix 2 – HART® Additional Functions

Note: The instructions that follow assume that a suitable HART® host (handheld or PC) is connected to the Searchpoint Optima Plus and that the user is logged in with Level 1 access privileges.

Caution: After changing any parameter, poll the Searchpoint Optima Plus and verify that the received value is correct.

20.1 Changing the Target Gas

Searchpoint Optima Plus is supplied with look-up tables for several different gases. If required, the gas table can be changed to a different target gas.

WARNING
 If a new gas table is selected, the Searchpoint Optima Plus **MUST** be re-calibrated using the target gas.

1. Select **Device Setup**.
2. Select **Gas Configuration** then **Gas Selection**.
3. Select **Choose Gas**.

Searchpoint Optima Plus stores a number of gas tables up to a maximum of 10. These include the Standard Gases (Methane, Ethane, Propane, Butane for Hydrocarbon units, Ethylene for Ethylene units) plus any Special Gases that have been specified when the unit was ordered. (For a full list of gases available to order please see Specification).

Caution: Searchpoint Optima Plus units contain a gas table called Linear 20R which is a factory setting. DO NOT select this gas table.

The new gas is chosen by selecting First Gas, Last Gas, Next Gas or Previous Gas. To assist in navigating to find the required new gas, please see the example table below: -

Location	Hydrocarbon Units	Ethylene Units
1	Methane	Ethylene
2	Ethane	Special Gases
3	Propane	Special Gases
4	Butane	Special Gases
5	Special Gases	Special Gases
6	Special Gases	Special Gases
7	Special Gases	Special Gases
8	Special Gases	Special Gases
9	Special Gases	Special Gases
10	Linear 20R (DO NOT USE)	Linear 20R (DO NOT USE)

For example, if the unit is currently configured for propane, to change to methane select First Gas. If it is configured for butane, to change to propane select Previous Gas.

Note: The order of the gas tables in the Searchpoint Optima Plus is by part number, therefore the standard gases may not be the first listed.

20. Appendix 2 – HART® Additional Functions

4. Select the required navigation, for example **Next Gas** and press **Enter**.
5. The display will show a confirmation message, press **OK**.
6. The display will show the message “Checking availability of chosen gas”, press **OK**.
7. The display will show the message “No specific error”, press **OK**.
8. The display now shows the current gas and the new gas. Repeat steps 4 to 6 until the correct new gas is found.
9. To confirm the change to the new gas select **Accept Choose Gas**.
10. Highlight **Accept Selection** and press **Enter**. (Alternatively, to keep the current gas, select **Abort Selection** and press **Enter**).
11. The display will show a confirmation message, press **OK**.
12. The display will show the message “No specific error”, press **OK**.
13. Press **Back** twice to return to the Device Setup menu.

The Searchpoint Optima Plus must now be calibrated using the new target gas. Use a cylinder of the target gas, of approximately 50 %FSD, with an accuracy of at least $\pm 2\%$.

Do not calibrate Searchpoint Optima Plus during periods of very high or low atmospheric pressure, very strong winds or storms.

Caution: Gas readings will be generated during this procedure. The 4-20 mA output will be inhibited automatically. If the procedure is aborted, ensure that the unit is not left in Inhibit mode.

Note: The unit should be powered up for 1 hour before a calibration is done.

Note: The calibration routine will timeout after 2 minutes of inactivity.

14. Using a ½ inch / 13 mm A/F open ended spanner, unscrew the two retaining nuts and remove the Standard Weather Protection from the Searchpoint Optima Plus.
15. Fit a Calibration Cap to the Searchpoint Optima Plus. Ensure it is pushed on fully.
16. Select **Calibrate**
17. Select **Gas Calibration**.
18. The display shows a warning message, press **OK**.
19. Ensure that there is zero gas present in the vicinity of the Searchpoint Optima Plus. If necessary, apply zero gas at a rate of 1 – 1.5 litres per minute.
20. When the gas reading on the display is stable press **OK** to initiate the Zero Calibration and then wait for approximately 15 s. The 4-20 mA output will be inhibited automatically at this time.
21. The display shows a message that the Zero Calibration was successful and offers to exit without a Span Calibration. Select **No** and press **Enter**.
22. Enter the concentration of the span calibration gas and press **Enter**.
23. Apply calibration gas at a rate of 1 – 1.5 litres per minute. Wait for the gas reading to stabilise (~ 30 - 60 s), then press **OK** to initiate the Span Calibration and then wait for approximately 15 s.
24. The display shows a message that the Span Calibration was successful. Remove the Calibration Cap and wait for the test gas to clear (~ 30 s).
25. Ensure that the gas reading has returned to zero. Press **OK** to release the 4-20 mA output.
26. The display shows a note that the Searchpoint Optima Plus will return to normal operation, press **OK**.
27. Return to the Welcome screen.
28. Refit the Standard Weather Protection and the two retaining nuts.

20. Appendix 2 – HART® Additional Functions

20.2 Set HART® Loop Current Mode

Searchpoint Optima Plus supports Point-to-Point HART® and HART® Multi-Drop configurations.

WARNING

HART® Multi-Drop Mode is not failsafe. Searchpoint Optima Plus in HART® Multi-Drop Mode is not SIL-2 compliant. Searchpoint Optima Plus in HART® Multi-Drop Mode is outside the scope of any performance approvals.

Caution: In Multi-Drop mode, the current loop should be AC coupled

Note: When Searchpoint Optima Plus is set in Multi-Drop Mode, the 4-20 mA loop cannot be calibrated and any functions that force the 4-20 mA output to a set value are unavailable.

1. Select **Device Setup**.
2. Select **Device Info**.
3. Select **Loop Current Mode**.
4. Select the required option and press **Enter**.
5. Press **Send** to send the information to Searchpoint Optima Plus.
6. The display shows a warning message. Press **OK**.
7. The communication mode is set and the display shows another warning message. Press **OK**.
8. Check that the display now shows the correct communication mode.
9. Press **Back** to return to Device Setup menu.

For use in Multi-Drop Mode the HART® address must also be configured between 1 and 63.

10. Select **Assembly Details**.
11. Select **HART® Address**.
12. Enter the required HART® address and press **Enter**.
13. Press **Send** to send the information to Searchpoint Optima Plus.
14. Return to the Welcome screen.

21. Appendix 3 – Special Notes for Honeywell MC Toolkit Users

Read these notes if the Honeywell MC Toolkit is being used to communicate with Searchpoint Optima Plus.

Please be aware that in some cases the MC Toolkit will not display messages as detailed in these instructions.

Several specific instances are given below: -

1. In section 12.7, “Calibrate the 4-20 mA Loop” the MC Toolkit will not display a message that data is being collected between steps 6 and 7, and between steps 9 and 10.
2. In section 13.6 “Re-zero Searchpoint Optima Plus” the MC Toolkit will not display a message that data is being collected during step 6.
3. In section 13.7 “Calibration” the MC Toolkit will not display a message that data is being collected during steps 8 and 12.

The MC Toolkit will not display any punctuation in the software version, e.g. version 5.2 will be displayed as version 52.

22. Appendix 4 – End Of Life Battery Removal

When Searchpoint Optima Plus reaches the end of its life, it should be disposed of in accordance with local regulations.

Searchpoint Optima Plus contains a lithium battery of the type CR2032, which can be located and removed as follows.

WARNING

The battery does not need to be replaced during the working life of the unit. Opening the Searchpoint Optima Plus enclosure will invalidate its warranty and certification.

1. Remove the two main assembly screws (M5) which hold the two sections of the Searchpoint Optima Plus together.
2. Remove the “back end” section, which includes the potted cables.
3. Looking inside this section, locate the two screws that hold the printed circuit board in place.

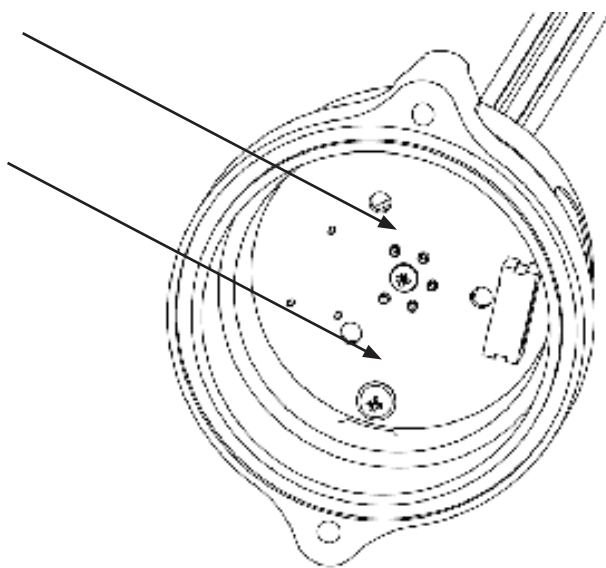

4. Remove the two screws and remove the printed circuit board. The battery is located on the underside of the board.
5. Cut the contacts to the printed circuit board to remove the battery.
6. Dispose of the battery in accordance with local regulations.

23. Appendix 5 – HART® Commands Used

23.1 Universal Commands

Searchpoint Optima Plus responds to the Universal Commands. One Dynamic Variable is implemented – Gas Concentration.

Additional comments: -

- Command #3 returns loop current and PV.
- Command #14: Units for sensor limits and minimum span are fixed. Sensor serial number is not used, and returns 0
- Command #38: Reset “Configuration Changed” Flag
- Command #48: Read Additional Device Status

23.2 Common-Practice Commands

23.2.1 Supported Commands

The following common-practice commands are implemented:

Command Number	Description
40	Enter/Exit Fixed Current Mode
41	Perform Device Self-Test
42	Perform Master Reset
45	Trim DAC Zero
46	Trim DAC Gain

23.2.2 Burst Mode

Searchpoint Optima Plus does not support Burst Mode.

23.2.3 Catch Device Variable

Searchpoint Optima Plus does not support Catch Device Variable.

23. Appendix 5 – HART® Commands Used

23.3 Device-Specific Commands

The following device-specific commands are implemented:

Command Number	Description
128	Read Gas Table Name
129	Read available Gas Table Name
130	Write Gas Table Index
132	Read Event Log history
133	Read Diagnostics (Warnings or faults)
135	Simulate Alarm or Warning or Fault
138	Write Alarm1 threshold
139	Read Alarm1 threshold
140	User Authentication
142	Password change
143	Enter/Exit Inhibit mode
146	Bump Test
147	Read Field Data
149	Read Real Time Clock
150	Write Real Time Clock
151	Read HART communication status during device fault
152	Write HART communication status during device fault
153	Read Inhibit current
154	Write Inhibit current
155	Read Warning current
156	Write Warning current
157	Read Over range current
158	Write Over range current
159	Clear latched faults and logged faults (partial or full)
160	Read Current operating mode

Find out more at:

www.honeywellanalytics.com

Contact Honeywell Analytics:

Europe, Middle East, Africa

Life Safety Distribution GmbH
Javastrasse 2
8604 Hegnau
Switzerland
Tel: +41 (0)44 943 4300
Fax: +41 (0)44 943 4398
gasdetection@honeywell.com

Customer Service:

Tel: 00800 333 222 44 (Freephone number)
Tel: +41 44 943 4380 (Alternative number)
Fax: 00800 333 222 55
Middle East Tel: +971 4 450 5800 (Fixed Gas Detection)
Middle East Tel: +971 4 450 5852 (Portable Gas Detection)

Russia

АО «ХОНЕВЕЛЛ»
121059, Россия, Москва
ул. Киевская, д. 7, 8 этаж
Тел. +7 (495) 796 9800
Факс +7 (495) 796 9893/94
info@honeywell.ru

Americas

Honeywell Analytics Inc.
405 Barclay Blvd.
Lincolnshire, IL 60069
USA
Tel: +1 847 955 8200
Toll free: +1 800 538 0363
Fax: +1 847 955 8210
detectgas@honeywell.com

Asia Pacific

Honeywell Analytics Asia Pacific
7F SangAm IT Tower, 434 World cup buk-ro,
Sangam-dong, Mapo-gu,
Seoul 152-729
Korea
Tel: +82 (0)2 6909 0300
Fax: +82 (0)2 2025 0328
India Tel: +91 124 4752700
analytics.ap@honeywell.com

Technical Services

EMEA: HAexpert@honeywell.com
US: ha.us.service@honeywell.com
AP: ha.ap.service@honeywell.com

www.honeywell.com

Please Note:

While every effort has been made to ensure accuracy in this publication, no responsibility can be accepted for errors or omissions. Data may change, as well as legislation and you are strongly advised to obtain copies of the most recently issued regulations, standards and guidelines. This publication is not intended to form the basis of a contract.

12831_Issue 7_07/2017
H_MAN0905_EMEA
2108M0550
© 2017 Honeywell Analytics

Honeywell