



Searchpoint Optima Plus

Contents

Section	Page
1. Safety Parameters	3
1.1 Proof Test Interval	3
1.2 Special Notes	3
2. Proof test using SHC1 Handheld Interrogator	4
2.1 Inspection	4
2.1.1 Inspection of a unit fitted with a Standard Weather Protection	4
2.1.2 Inspection of a unit fitted with a Flow Housing	5
2.2 Re-zero Searchpoint Optima Plus	6
2.3 Bump Test (Gas Challenge)	6
2.3.1 Bump Test (Gas Challenge) for a unit fitted with a Standard Weather Protection	6
2.3.2 Bump Test (Gas Challenge) for a unit fitted with a Flow Housing	6
2.4 Fix the 4-20 mA Output	7
3. Proof test using HART® Communications	8
3.1 Inspection	8
3.1.1 Inspection of a unit fitted with a Standard Weather Protection	8
3.1.2 Inspection of a unit fitted with a Flow Housing	9
3.2 Re-zero Searchpoint Optima Plus	10
3.3 Bump Test (Gas Challenge)	11
3.3.1 Bump Test (Gas Challenge) for a unit fitted with a Standard Weather Protection	11
3.3.2 Bump Test (Gas Challenge) for a unit fitted with a Flow Housing	11
3.4 Fix the 4-20 mA Output	12
4. Proof test for a Searchpoint Optima Plus being used with an XNX Universal Transmitter	13
4.1 Inspection	13
4.1.1 Inspection of a unit fitted with a Standard Weather Protection	13
4.1.2 Inspection of a unit fitted with a Flow Housing	14
4.2 XNX Universal Transmitter Proof Test	14

1. Safety Parameters

The Searchpoint Optima Plus safety parameters listed below were provided by TÜV in report 968/EZ 559.00/12.

SFF	PFD _{avg}	PFH
> 90%	2.13×10^{-4}	4.87×10^{-8}

SFF: Safe Failure Fraction. A percentage of safe failures as compared to all failures

PFD_{avg}: Average probability of failure to perform its design function on demand

PFH: Probability of a dangerous failure per hour

1.1 Proof Test Interval

The purpose of a proof test is to return the unit to “as new” in terms of its safety parameters.

The proof test interval is 1 year.

According to IEC 61508, users are allowed to extend the proof test interval to meet their system needs. Honeywell allows such an extension, as long as the user follows the proper calculation method for calculating a proof test interval as defined in IEC 61508 for the desired SIL level. This proof test interval will vary depending on system, hardware architecture and application.

Note: The proof test interval should not preclude more frequent maintenance of Searchpoint Optima Plus in accordance with the Operating Instructions if site conditions require it.

1.2 Special Notes

1. The HART® Communications and the RS485 link must not be used for safety purposes.
2. Under a certain extremely rare combination of fault conditions, there is a risk that Searchpoint Optima Plus could output >100 mA. Should a customer be concerned about this, it is recommended that a suitable fuse is fitted in the 4-20 mA output line.
3. Searchpoint Optima Plus must be protected from over voltage conditions (i.e. above the supply voltage specification).

2. Proof test using SHC1 Handheld Interrogator

Use these proof test instructions if the SHC1 Handheld Interrogator is being used to communicate with Searchpoint Optima Plus.

Note: The instructions that follow assume that the SHC1 is connected to the Searchpoint Optima Plus and switched on, in Optima+ mode, in the Main Menu. See the Searchpoint Optima Plus Operating Instructions, 2108M0550, for further information about the operation of the SHC1 Handheld Interrogator.

2.1 Inspection

2.1.1 Inspection of a unit fitted with a Standard Weather Protection

Searchpoint Optima Plus should be inspected and cleaned.

Caution: Gas readings may be generated during this procedure.

1. Select **Calibrate** then **Display** to inhibit the 4-20 mA output signal.
2. Inspect the Searchpoint Optima Plus unit, its junction box and cabling for any signs of physical damage.
3. Using a ½ inch / 13 mm A/F open ended spanner, unscrew the two retaining nuts and remove the Standard Weather Protection.
4. Inspect the Standard Weather Protection for damage or build up of debris / contaminants. If required, clean or replace weather protection.
5. Inspect the Dust Barrier and clean or replace if required.
6. Remove the Dust Barrier and inspect the optics.
7. Clean any dust or contaminants from the optics using mild detergent and a soft cloth or cotton bud. Do not use solvents or abrasive cleaners.
8. Press **Escape** then **Enter** to release the 4-20 mA output signal.
9. Block the optical beam (for example using the cleaning cloth).

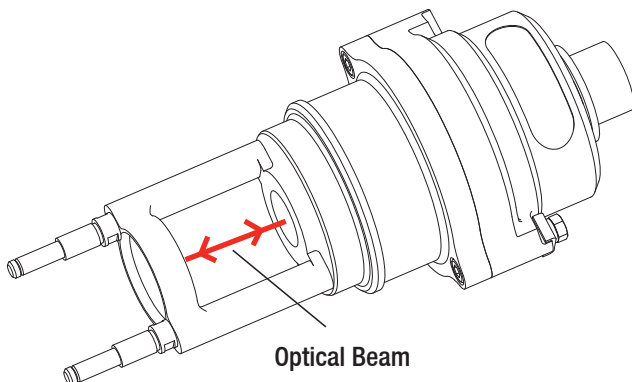

10. Confirm that a fault is generated on the 4-20 mA output, either locally or at the controller.

Note: The 4-20 mA output can be monitored either at the control room or locally with a multimeter. When connecting or disconnecting a multimeter, power off the Searchpoint Optima Plus, otherwise the unit will indicate a latched warning that the 4-20 mA loop was broken. If this occurs it can be cleared by performing a Soft Reset.

11. Remove the blockage from the beam.
12. Select **Calibrate** then **Display** to inhibit the 4-20 mA output signal.

2. Proof test using SHC1 Handheld Interrogator

13. Replace the Dust Barrier and Standard Weather Protection.
14. Press **Escape** then **Enter** to release the 4-20 mA output signal.
15. Press **Escape** to return to the main menu.
16. Select **Diagnose** then **Soft Reset** to clear any faults or warnings that may have been generated by cleaning.
17. Press **Escape** to return to the main menu.

2.1.2 Inspection of a unit fitted with a Flow Housing

Searchpoint Optima Plus should be inspected and cleaned.

Caution: Gas readings may be generated during this procedure.

1. Select **Calibrate** then **Display** to inhibit the 4-20 mA output signal.
2. Inspect the Searchpoint Optima Plus unit, its junction box and cabling for any signs of physical damage.
3. Disconnect any pipework attached to the flow housing.
4. Using a ½ inch / 13 mm A/F open ended spanner, remove the two black nuts which retain the flow housing. Keep the O-ring seals which are below the retaining nuts.
5. Slide the flow housing off the Searchpoint Optima Plus. This may require some force due to the friction of the O-ring.
6. Clean any dust or contaminants from the optics using mild detergent and a soft cloth or cotton bud. Do not use solvents or abrasive cleaners.
7. Press **Escape** then **Enter** to release the 4-20 mA output signal.
8. Block the optical beam (for example using the cleaning cloth)

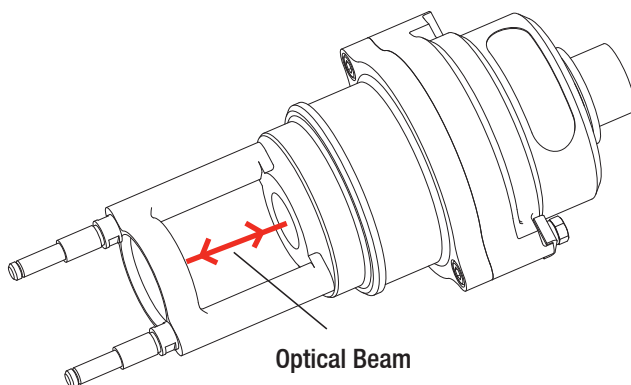

9. Confirm that a fault is generated on the 4-20 mA output, either locally or at the controller.

Note: The 4-20 mA output can be monitored either at the control room or locally with a multimeter. When connecting or disconnecting a multimeter, power off the Searchpoint Optima Plus, otherwise the unit will indicate a latched warning that the 4-20 mA loop was broken. If this occurs it can be cleared by performing a Soft Reset.

10. Remove the blockage from the beam
11. Select **Calibrate** then **Display** to inhibit the 4-20 mA output signal.
12. Ensure that the large sealing O-ring in the body of the flow housing, and the two small O-rings which go below the retaining nuts, are clean and in good condition. Replace if in doubt.
13. Slide the flow housing over the end of the Searchpoint Optima Plus and push until the flow housing is firmly seated.

2. Proof test using SHC1 Handheld Interrogator

14. Re-fit the O-rings and retaining nuts.
15. Press **Escape** then **Enter** to release the 4-20 mA output signal.
16. Press **Escape** to return to the main menu.
17. Select **Diagnose** then **Soft Reset** to clear any faults or warnings that may have been generated by cleaning.
18. Press **Escape** to return to the main menu.

2.2 Re-zero Searchpoint Optima Plus

1. Select **Calibrate** then **CalSensor**. (This will inhibit the 4-20 mA output signal).
2. Ensure that there is zero gas present in the vicinity of the Searchpoint Optima Plus. If necessary, fit a Gassing Cover and apply zero gas.
3. Press **Enter**.

When the process is complete the display will state Zero Calibrated. It will then show options to continue to a span calibration, or to exit calibration.

4. Press **Escape** to exit calibration.
5. Press **Enter** to release the 4-20 mA output signal.
6. Press **Escape** to return to the main menu.

Note: If the option to Calibrate Span is selected in error, press Escape.

2.3 Bump Test (Gas Challenge)

2.3.1 Bump Test (Gas Challenge) for a unit fitted with a Standard Weather Protection

Searchpoint Optima Plus should be functionally checked using an appropriate test gas.

Caution: Gas readings will be generated during this procedure.

Note: The unit should be powered up for 1 hour before a gas test is done.

1. Fit a Gassing Cover to the Searchpoint Optima Plus, if not already in place.
2. Apply an appropriate test gas at a rate of 1 – 1.5 litres per minute for ~ 30 - 60 s.
3. Check that the Searchpoint Optima Plus responds to the test gas.
4. Remove the Gassing Cover and wait for the test gas to clear (~ 30 s). Ensure that the gas reading has returned to zero.

2.3.2 Bump Test (Gas Challenge) for a unit fitted with a Flow Housing

Searchpoint Optima Plus should be functionally checked using an appropriate test gas.

Caution: Gas readings will be generated during this procedure.

Note: The unit should be powered up for 1 hour before a gas test is done.

1. Apply an appropriate test gas, using the same flow rate as the sampling system in which the Searchpoint Optima Plus is installed.
2. Check that the Searchpoint Optima Plus responds to the test gas.
3. Apply zero gas and wait for the gas reading to return to zero.

2. Proof test using SHC1 Handheld Interrogator

2.4 Fix the 4-20 mA Output

The 4-20 mA output can be set to a fixed value, to prove correct operation of the 4-20 mA loop.

Note: The 4-20 mA output can be monitored either at the control room or locally with a multimeter. When connecting or disconnecting a multimeter, power off the Searchpoint Optima Plus, otherwise the unit will indicate a latched warning that the 4-20 mA loop was broken. If this occurs it can be cleared by performing a Soft Reset.

1. Select **Calibrate** then **Force 4-20**.
2. Use ▲ and ▼ to set the mA value to 4 mA and press **Enter**.
3. Check that Searchpoint Optima Plus outputs the set mA value.
4. When the test is complete, press **Enter**.
5. Repeat steps 2 - 4 for mA values of 12 mA and 20 mA.
6. Press **Enter** to release the 4-20 mA output signal.
7. Press **Escape** to return to the main menu.

3. Proof test using HART® Communications

Use these proof test instructions if the HART® Communications are being used to communicate with Searchpoint Optima Plus.

Note: The instructions that follow assume that a suitable HART® host (handheld or PC) is connected to the Searchpoint Optima Plus and that the user is logged in with Level 1 access privileges. See the Searchpoint Optima Plus Operating Instructions, 2108M0550, for further information about the operation of the HART® Communications.

3.1 Inspection

3.1.1 Inspection of a unit fitted with a Standard Weather Protection

Searchpoint Optima Plus should be inspected and cleaned.

Caution: Gas readings may be generated during this procedure. Follow the steps to inhibit the 4-20 mA output. Ensure that the unit is not left in Inhibit mode.

1. Select **Device Setup**.
2. Select **Test**.
3. Select **Inhibit**.
4. Select **Start Inhibit** and press **Enter**.
5. The display shows a confirmation message. Press **OK**. The 4-20 mA output is now inhibited.
6. Inspect the Searchpoint Optima Plus unit, its junction box and cabling for any signs of physical damage.
7. Using a ½ inch / 13 mm A/F open ended spanner, unscrew the two retaining nuts and remove the Standard Weather Protection.
8. Inspect the Standard Weather Protection for damage or build up of debris / contaminants. If required, clean or replace weather protection.
9. Inspect the Dust Barrier and clean or replace if required.
10. Remove the Dust Barrier and inspect the optics.
11. Clean any dust or contaminants from the optics using mild detergent and a soft cloth or cotton bud. Do not use solvents or abrasive cleaners.
12. Select **Inhibit**.
13. Select **End Inhibit** and press **Enter**.
14. The display shows a confirmation message. Press **OK** to release the 4-20 mA output.
15. Block the optical beam (for example using the cleaning cloth)

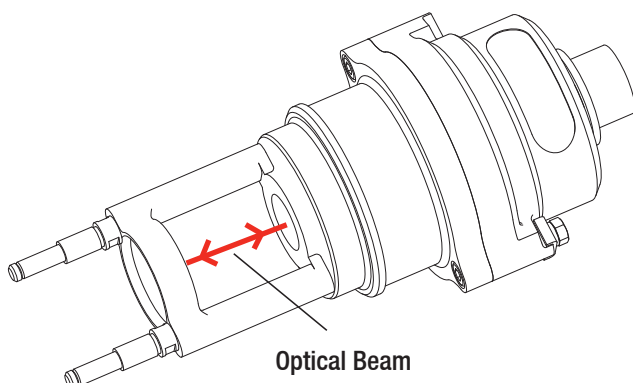

3. Proof test using HART® Communications

16. Confirm that a fault is generated on the 4-20 mA output, either locally or at the controller.

Note: The 4-20 mA output can be monitored either at the control room or locally with a multimeter. When connecting or disconnecting a multimeter, power off the Searchpoint Optima Plus, otherwise the unit will indicate a latched warning that the 4-20 mA loop was broken. If this occurs it can be cleared by performing a Device Reset.

17. Remove the blockage from the beam.

18. Select **Inhibit**.

19. Select **Start Inhibit** and press **Enter**.

20. The display shows a confirmation message. Press **OK**. The 4-20 mA output is now inhibited.

21. Replace the Dust Barrier and Standard Weather Protection.

22. Select **Device Reset** to clear any faults or warnings that may have been generated by cleaning.

23. Press **OK** to initiate a Device Reset.

24. The display shows a confirmation message. Press **OK**.

25. The display shows a note that the Searchpoint Optima Plus will return to normal operation, press **OK**.

26. Select **Inhibit**.

27. Select **End Inhibit** and press **Enter**.

28. The display shows a confirmation message. Press **OK** to release the 4-20 mA output.

29. Return to the Welcome screen.

3.1.2 Inspection of a unit fitted with a Flow Housing

Searchpoint Optima Plus should be inspected and cleaned.

Caution: Gas readings may be generated during this procedure. Follow the steps to inhibit the 4-20 mA output. Ensure that the unit is not left in Inhibit mode.

1. Select **Device Setup**.

2. Select **Test**.

3. Select **Inhibit**.

4. Select **Start Inhibit** and press **Enter**.

5. The display shows a confirmation message. Press **OK**. The 4-20 mA output is now inhibited.

6. Inspect the Searchpoint Optima Plus unit, its junction box and cabling for any signs of physical damage.

7. Disconnect any pipework attached to the flow housing.

8. Using a ½ inch / 13 mm A/F open ended spanner, remove the two black nuts which retain the flow housing. Keep the O-ring seals which are below the retaining nuts.

9. Slide the flow housing off the Searchpoint Optima Plus. This may require some force due to the friction of the O-ring.

10. Clean any dust or contaminants from the optics using mild detergent and a soft cloth or cotton bud. Do not use solvents or abrasive cleaners.

11. Select **Inhibit**.

12. Select **End Inhibit** and press **Enter**.

13. The display shows a confirmation message. Press **OK** to release the 4-20 mA output.

14. Block the optical beam (for example using the cleaning cloth).

3. Proof test using HART® Communications

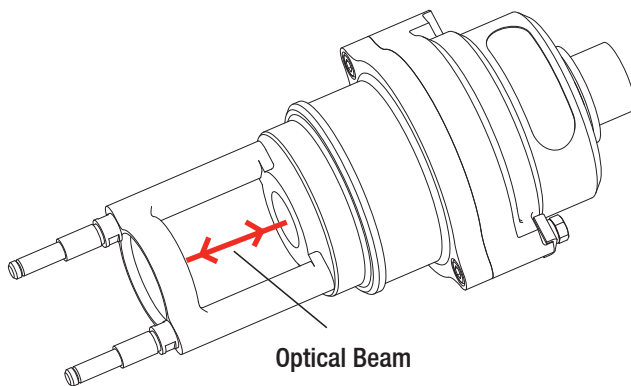

15. Confirm that a fault is generated on the 4-20 mA output, either locally or at the controller.

Note: The 4-20 mA output can be monitored either at the control room or locally with a multimeter. When connecting or disconnecting a multimeter, power off the Searchpoint Optima Plus, otherwise the unit will indicate a latched warning that the 4-20 mA loop was broken. If this occurs it can be cleared by performing a Device Reset.

16. Remove the blockage from the beam.

17. Select **Inhibit**.

18. Select **Start Inhibit** and press **Enter**.

19. The display shows a confirmation message. Press **OK**. The 4-20 mA output is now inhibited.

20. Ensure that the large sealing O-ring in the body of the flow housing, and the two small O-rings which go below the retaining nuts, are clean and in good condition. Replace if in doubt.

21. Slide the flow housing over the end of the Searchpoint Optima Plus and push until the flow housing is firmly seated.

22. Re-fit the O-rings and retaining nuts.

23. Select **Device Reset** to clear any faults or warnings that may have been generated by cleaning.

24. Press **OK** to initiate a Device Reset.

25. The display shows a confirmation message. Press **OK**.

26. The display shows a note that the Searchpoint Optima Plus will return to normal operation, press **OK**.

27. Select **Inhibit**.

28. Select **End Inhibit** and press **Enter**.

29. The display shows a confirmation message. Press **OK** to release the 4-20 mA output.

30. Return to the Welcome screen.

3.2 Re-zero Searchpoint Optima Plus

Caution: During this procedure the 4-20 mA output will be inhibited automatically. If the procedure is aborted, ensure that the unit is not left in Inhibit mode.

Note: the calibration routine will timeout after 2 minutes of inactivity.

1. Select **Device Setup**.

2. Select **Calibrate**.

3. Select **Gas Calibration**.

4. The display shows a warning message, press **OK**.

5. Ensure that there is zero gas present in the vicinity of the Searchpoint Optima Plus. If necessary, fit a Gassing Cover and apply zero gas.

3. Proof test using HART® Communications

6. When the gas reading on the display is stable press **OK** to initiate the Zero Calibration and then wait for approximately 15s. The 4-20 mA output will be inhibited automatically at this time.
7. The display shows a message that the Zero Calibration was successful and offers to exit without a Span Calibration. Select **Yes** and press **Enter**.
8. The display shows a note that the Searchpoint Optima Plus will return to normal operation, press **OK**.
9. Return to the Welcome screen.

3.3 Bump Test (Gas Challenge)

3.3.1 Bump Test (Gas Challenge) for a unit fitted with a Standard Weather Protection

Searchpoint Optima Plus should be functionally checked using an appropriate test gas.

Caution: Gas readings will be generated during this procedure.

Note: Do not use the HART® Communications Bump Test routine as this will automatically inhibit the 4-20 mA signal.

Note: The unit should be powered up for 1 hour before a gas test is done.

1. Fit a Gassing Cover to the Searchpoint Optima Plus.
2. Apply an appropriate test gas at a rate of 1 – 1.5 litres per minute for ~ 30 - 60 s.
3. Check that the Searchpoint Optima Plus responds to the test gas. The live gas concentration is shown on the screen.
4. Remove the Gassing Cover and wait for the test gas to clear (~ 30 s). Ensure that the gas reading has returned to zero.

3.3.2 Bump Test (Gas Challenge) for a unit fitted with a Flow Housing

Searchpoint Optima Plus should be functionally checked using an appropriate test gas.

Caution: Gas readings will be generated during this procedure.

Note: Do not use the HART® Communications Bump Test routine as this will automatically inhibit the 4-20 mA signal.

Note: The unit should be powered up for 1 hour before a gas test is done.

1. Apply an appropriate test gas, using the same flow rate as the sampling system in which the Searchpoint Optima Plus is installed.
2. Check that the Searchpoint Optima Plus responds to the test gas.
3. Apply zero gas and wait for the gas reading to return to zero.

3. Proof test using HART® Communications

3.4 Fix the 4-20 mA Output

The 4-20 mA output can be set to a fixed value, to prove correct operation of the 4-20 mA loop.

Note: This function will timeout after 10 minutes of inactivity.

Note: The 4-20 mA output can be monitored either at the control room or locally with a multimeter. When connecting or disconnecting a multimeter, power off the Searchpoint Optima Plus, otherwise the unit will indicate a latched warning that the 4-20 mA loop was broken. If this occurs, it can be cleared by performing a Device Reset.

1. Select **Device Setup**.
2. Select **Test**.
3. Select **mA Loop Test**.
4. The display shows a warning message, press **OK**.
5. Select 4 mA as the required analogue output level and press **Enter**.
6. Check that Searchpoint Optima Plus outputs the set mA value.
7. When ready, press **OK**.
8. Repeat steps 4 to 7 for mA values of 12 mA and 20 mA, then select **End**.
9. The display shows a note that the Searchpoint Optima Plus will return to normal operation, press **OK**.
10. The display shows a confirmation message, return to the Welcome screen.

4. Proof test for a Searchpoint Optima Plus being used with an XNX Universal Transmitter

Use these proof test instructions if Searchpoint Optima Plus is being used with an XNX Universal Transmitter.

Note: If Searchpoint Optima Plus is being used with the XNX Universal Transmitter, it must be tested as part of a system with XNX. Therefore in addition to the proof test detailed below, also complete the XNX proof test described in the XNX Safety Manual. See the XNX Quick Start Guide and the XNX Technical Manual for further information about the operation of the XNX Universal Transmitter.

4.1 Inspection

4.1.1 Inspection of a unit fitted with a Standard Weather Protection

Searchpoint Optima Plus should be inspected and cleaned.

Caution: Gas readings may be generated during this procedure.

1. Select **Test Mode**, then **Inhibit** and **Set Inhibit On** to inhibit the 4-20 mA output signal.
2. Inspect the Searchpoint Optima Plus unit, its junction box and cabling for any signs of physical damage.
3. Using a ½ inch / 13 mm A/F open ended spanner, unscrew the two retaining nuts and remove the Standard Weather Protection.
4. Inspect the Standard Weather Protection for damage or build up of debris / contaminants. If required, clean or replace weather protection.
5. Inspect the Dust Barrier and clean or replace if required.
6. Remove the Dust Barrier and inspect the optics.
7. Clean any dust or contaminants from the optics using mild detergent and a soft cloth or cotton bud. Do not use solvents or abrasive cleaners.
8. Block the optical beam (for example using the cleaning cloth).

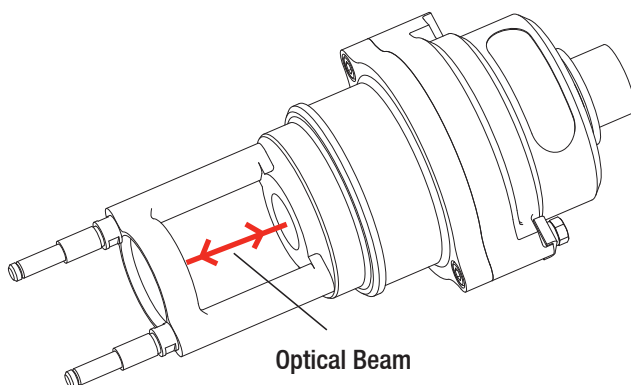

9. Confirm that a fault is generated by viewing the indication on the XNX display.
10. Remove the blockage from the beam.
11. Replace the Dust Barrier and Standard Weather Protection.
12. Select **Set Inhibit Off** to release the 4-20 mA output signal.
13. Return to the main menu.
14. Select **Calibration Mode** then **Soft Reset** to clear any faults or warnings that may have been generated by cleaning.

4. Proof test for a Searchpoint Optima Plus being used with an XNX Universal Transmitter

4.1.2 Inspection of a unit fitted with a Flow Housing

Searchpoint Optima Plus should be inspected periodically and cleaned if necessary. The required frequency of inspection will depend on local site conditions and will need to be established through experience.

Caution: Gas readings may be generated during this procedure.

1. Select **Test Mode**, then **Inhibit** and **Set Inhibit On** to inhibit the 4-20 mA output signal.
2. Inspect the Searchpoint Optima Plus unit, its junction box and cabling for any signs of physical damage.
3. Disconnect any pipework attached to the flow housing.
4. Using a ½ inch / 13 mm A/F open ended spanner, remove the two black nuts which retain the flow housing. Keep the O-ring seals which are below the retaining nuts.
5. Slide the flow housing off the Searchpoint Optima Plus. This may require some force due to the friction of the O-ring.
6. Clean any dust or contaminants from the optics using mild detergent and a soft cloth or cotton bud. Do not use solvents or abrasive cleaners.
7. Block the optical beam (for example using the cleaning cloth).

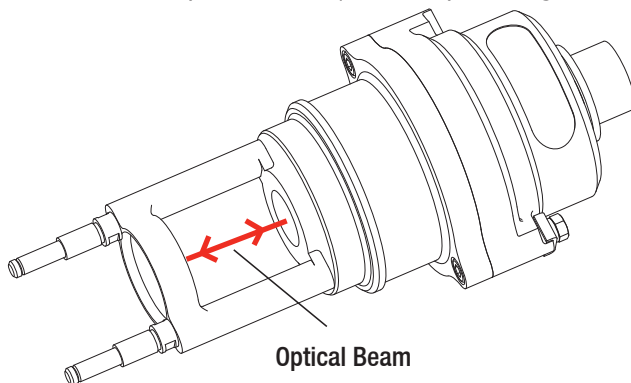

8. Confirm that a fault is generated by viewing the indication on the XNX display.
9. Remove the blockage from the beam.
10. Ensure that the large sealing O-ring in the body of the flow housing, and the two small O-rings which go below the retaining nuts, are clean and in good condition. Replace if in doubt.
11. Slide the flow housing over the end of the Searchpoint Optima Plus and push until the flow housing is firmly seated.
12. Re-fit the o-rings and retaining nuts.
13. Select **Set Inhibit Off** to release the 4-20 mA output signal.
14. Return to the main menu.
15. Select **Calibration Mode** then **Soft Reset** to clear any faults or warnings that may have been generated by cleaning.

4.2 XNX Universal Transmitter Proof Test

After completing the tests in 4.1, please refer to the XNX Universal Transmitter Safety Manual (part number 1998-0808) and complete the Proof Test detailed there.

Find out more

www.honeywellanalytics.com

Contact Honeywell Analytics:**Europe, Middle East, Africa, India**

Life Safety Distribution AG
Javastrasse 2
8604 Hegnau
Switzerland
Tel: +41 (0)44 943 4300
Fax: +41 (0)44 943 4398
India Tel: +91 124 4752700
gasdetection@honeywell.com

Americas

Honeywell Analytics Inc.
405 Barclay Blvd.
Lincolnshire, IL 60069
USA
Tel: +1 847 955 8200
Toll free: +1 800 538 0363
Fax: +1 847 955 8210
detectgas@honeywell.com

Asia Pacific

Honeywell Analytics Asia Pacific
#508, Kolon Science Valley (I)
187-10 Guro-Dong, Guro-Gu
Seoul, 152-050
Korea
Tel: +82 (0)2 6909 0300
Fax: +82 (0)2 2025 0329
analytics.ap@honeywell.com

Technical Services

EMEA: HAexpert@honeywell.com
US: ha.us.service@honeywell.com
AP: ha.ap.service@honeywell.com

www.honeywell.com

Please Note:

While every effort has been made to ensure accuracy in this publication, no responsibility can be accepted for errors or omissions. Data may change, as well as legislation and you are strongly advised to obtain copies of the most recently issued regulations, standards and guidelines. This publication is not intended to form the basis of a contract.

Issue 1_05/2012
H_MAN0921_EMEA
2108M0552_ECO A03799
© 2012 Honeywell Analytics

The Honeywell logo is displayed in a bold, red, sans-serif font.