



Model MCX-32-N1P Model MCX-32-N4X Gas Detection Controller



Operator's Installation and Instruction Manual Covers all Model MCX-32 Control Systems

◆ DETCON, Inc.
4055 Technology Forest Blvd.,
The Woodlands, Texas 77381
Ph.281.367.4100 / Fax 281.298.2868
www.detcon.com

This page left intentionally blank

Table of Contents

1.0	Introduction.....	1
1.1	Description	1
1.2	Wireless Option.....	1
1.3	System Operation	3
1.3.1	Interface PCA.....	3
1.3.2	Communication Ports.....	4
1.3.3	Auxiliary Relays	4
1.3.4	Auxiliary 24VDC input.....	4
1.4	Programming Configuration.....	5
2.0	Installation.....	5
2.1	Safety Guidelines	5
2.2	N1P and N1R Enclosure Installation.....	6
2.2.1	Mounting and Cable Installation.....	6
2.2.2	Power Connections.....	6
2.2.3	AC Power	7
2.2.4	DC Power.....	7
2.3	N4X Enclosure Installation	8
2.3.1	Mounting and Cable Installation.....	8
2.3.2	Power Connections.....	8
2.3.3	AC Power	9
2.3.4	DC Power.....	10
3.0	I/O Connections	12
3.1	Analog 4-20mA Sensor Inputs (DA-4)	12
3.2	Dry Contact Inputs (DI-4)	15
3.3	Analog 4-20mA Outputs (AO-4).....	16
3.4	Alarm Relay Outputs (RL-4).....	19
3.4.1	Energized or De-Energized.....	20
3.4.2	Silenceable or Non-Silenceable.....	21
3.4.3	Latching or Non-Latching Relays	21
3.5	I/O Module Installation	21
3.6	Serial Output Gas Sensors (RS-485)	22
3.7	Wireless RXT-320 Modbus™ Devices and CXT-320 Sensors	23
3.8	RXT-320 Wireless transceiver Analog Inputs	23
3.9	SmartWireless® CXT Sentinel Slave Controller	25
3.10	SmartWireless® CX Sentinel Sensor Station.....	27
3.11	Remote Monitoring and Control	29
3.12	Auxiliary Relays.....	29
3.13	General Wiring and Configuration Notes.....	30
3.14	Initial Start-Up.....	30
4.0	CompactFlash Card.....	31
5.0	Operation.....	32
5.1	Main Display Screen	32
5.1.1	Password Protection	34
5.2	Channel Details Screen	34
5.3	Wireless Transceiver Details Screen.....	35
5.4	Main Menu Screen	36

5.4.1	Auto Configure System Screen	37
5.4.2	Modbus Utilities Screen	38
5.4.3	Alarm Inhibit Screen.....	42
5.4.4	Turn ON/OFF Channels Screen.....	43
5.4.5	System Settings Screen	44
5.4.6	Restore Defaults Screen	49
5.4.7	Turn ON/OFF WTS	50
5.4.8	RLA/ALM STATION Setup Screen.....	50
5.4.9	Change Password Screen.....	52
5.4.10	WT Setup Screen.....	52
5.4.11	Alarm Test Mode Screen	54
5.4.12	Compact Flash Screen.....	55
5.4.13	About System Screen.....	59
6.0	Controller Setup.....	60
6.1	Sensor Channel Setup.....	65
6.2	Wireless Transceiver Channel Setup.....	70
7.0	Remote Display	72
7.1	Installation	72
7.2	Operation	73
7.2.1	Channel Details Screen	74
7.2.2	System Configuration Screen	74
7.3	Remote Setup	76
7.3.1	Sensor Channel Setup.....	76
8.0	Troubleshooting	77
8.1	Wireless Troubleshooting.....	79
9.0	Warranty and Customer Support	80
10.0	Specifications.....	81
10.1	Hexadecimal Table.....	82
10.2	Remote Display RS-485 Register Map	83
10.3	Spare Parts.....	85
10.4	Revision Log	85
11.0	Appendix.....	86
11.1	MCX-32 IP Address Documentation	86

Table of Figures

Figure 1	MCX-32 Wireless Transceiver	2
Figure 2	MCX-32-N1P Controller Mounting and Dimensional	6
Figure 3	MCX-32-N1R Controller Mounting and Dimensional	6
Figure 4	AC/DC Inputs	7
Figure 5	MCX-32-N4X Controller Mounting and Dimensional View	8
Figure 6	N4X Protective Earth Connector	9
Figure 7	Cable Entry Points	10
Figure 8	N4X AC/DC Inputs.....	11
Figure 9	RS-485 Wiring Terminals for PORT1, PORT2 and REMOTE.....	12
Figure 10	Model DA-4 4-20mA Input Module and 4-20mA Gas Sensor Connections	13
Figure 11	Model DA-4 4-20mA Input Module and 4-20mA Gas Sensors	14
Figure 12	Model DI-4 Contact Input Module	15

Figure 13 Model AO-4 4-20mA Output Module	17
Figure 14 Model RL-4 Relay Output Module.....	19
Figure 15 I/O Module Installation.....	21
Figure 16 Modbus™ (Serial) Gas Sensor Connections.....	22
Figure 17 Model 100 Terminal Board.....	24
Figure 18 CX/CXT Wireless Transceiver	25
Figure 19 CX/CXT Relay Output PCA.....	26
Figure 20 CX/CXT Analog Input PCA	26
Figure 21 MCX-32 Remote Interface	29
Figure 22 Interface PCA.....	29
Figure 23 CompactFlash Card Installation.....	31
Figure 24 Model MCX-32 Main Display Screen (Sensor Section).....	32
Figure 25 Model MCX-32 Main Display Screen (Wireless Transceiver Section).....	33
Figure 26 Model MCX-32 Main Display	34
Figure 27 Channel Details Screen.....	35
Figure 28 Wireless Transceiver Details Screen.....	36
Figure 29 Main Menu Screen.....	37
Figure 30 Auto Configure System Screen.....	38
Figure 31 Modbus Utilities.....	39
Figure 32 Device Modbus Diagnostics Screen	39
Figure 33 RL4/Alm Stn Diagnostics Screen	40
Figure 34 RL4/Alm Stn Diagnostics Screen	40
Figure 35 Modbus Timeout Screen	41
Figure 36 Update Intervals Screen	42
Figure 37 Reset All Counters Menu.....	42
Figure 38 Alarm Inhibit Screen.....	43
Figure 39 Turn ON/OFF Channels Screen.....	44
Figure 40 Display Settings	44
Figure 41 Time/Date Screen.....	45
Figure 42 Automatic Screen Switching Screen.....	46
Figure 43 Contrast/Brightness Screen	46
Figure 44 Modbus Address Screen	47
Figure 45 Calibration Screen.....	47
Figure 46 Power Management Screen (No Secondary Supply).....	48
Figure 47 Power Management with Battery Charge ‘ON’	49
Figure 48 Restore Defaults Screen.....	49
Figure 49 Turn ON/OFF WTS Screen	50
Figure 50 RL-4 Setup Screen	51
Figure 51 Auxiliary Relay Configuration Screen.....	52
Figure 52 Change Password Screen	52
Figure 53 WT Setup Screen	53
Figure 54 Low Battery Alarm Screen	53
Figure 55 RF Silence and RF Sleep Screen.....	54
Figure 56 Alarm Test Mode	55
Figure 57 Compact Flash Screen.....	56
Figure 58 TWA & PEAK Screen.....	56
Figure 59 Events Screen.....	57
Figure 60 Backup Configuration Screen	57
Figure 61 Restore Configuration Screen	58
Figure 62 Format CompactFlash Warning Window	58
Figure 63 About System Screen.....	59
Figure 64 Channel Details Screen.....	65

Figure 65 Channel Description Entry 66
Figure 66 Gas/Units Entry 67
Figure 67 Change Range Entry 67
Figure 68 Device Type Selection 68
Figure 69 Alarm Level Set 69
Figure 70 Alarm Bank 2 Select 69
Figure 71 Wireless Transceiver Details Screen 70
Figure 72 AC/DC Inputs 72
Figure 73 The MCX-32 Remote Main Display 73
Figure 74 Remote Channel 1 Details Screen 74
Figure 75 Remote Display System Configuration Screen 75

List of Tables

Table 1 DA-4/DI-4 Modbus Addresses 14
Table 2 AO-4 Modbus™ Addresses 18
Table 3 RL-4/Alarm Station Modbus™ Addresses 20
Table 4 Wireless Transceiver Analog Input Modbus™ Addresses 24
Table 5 Wireless CX Sensor Station Analog Input Card Modbus™ Addresses 28
Table 6 Input Device Modbus™ Addresses for Port 1 61
Table 7 Input Device Modbus™ Addresses for Port 2 62
Table 8 Input Device Configuration Example for Port 1 63
Table 9 Hexadecimal Conversion Table 82
Table 10 Remote Display RS-485 Register Map 83

1.0 Introduction

1.1 Description

The Detcon MCX-32 is a multi-channel gas detection controller designed to serve as a host monitor and controller for a wired and wireless network of gas detection sensors as well as a wide range of other field devices. All MCX-32 models are configurable for up to 64 channels and can communicate with serial sensors via wired or wireless RS-485 Modbus™. The MCX-32 can also interface with analog sensors using Detcon's selection of I/O modules and through RXT320 wireless transceiver analog inputs and CX Site Sentinels. The I/O modules communicate with the controller through Modbus™ and are available in four channel sets for 4-20mA inputs, contact closure inputs, relay outputs and 4-20mA outputs. The modules are DIN rail mounted and stackable allowing for seamless system expansion. The RXT-320 Modbus and analog inputs relate to the wireless option for the MCX-32. This option allows the controller to communicate with Detcon wireless devices using wireless transceivers to broadcast Modbus communications throughout a wireless network creating a network of Modbus devices that are not physically connected. The MCX-32 also provides a built in web server which enables remote monitoring and control via any web browser when it's interfaced to TCP/IP local networks with a DHCP Server.

Remote mounted gas detection sensors can include any analog 4-20mA or RS-485 (Modbus™) serial communication device, such as toxic gas, combustible gas or oxygen deficiency sensors. Other remote field devices can include contact closure inputs such as liquid level, temperature, pressure or smoke detection devices. Analog sensors and other field devices can be interfaced through I/O modules which communicate with the controller's Modbus™ port, or RXT-320 transceiver analog inputs, SmartWireless® CXT Slave Controllers, and SmartWireless® CX Sensor Stations, all of which enable an analog device to communicate wirelessly. Serial sensors and field devices interface directly with the controller's Modbus™ port and do not require I/O modules. Sensors and other field devices interfaced to Detcon's wireless transceivers will communicate wirelessly, thus, the type of device being interfaced will dictate the I/O modules and wireless transceivers needed for the MCX-32 controller. The controller is capable of identifying all of the Modbus™ wired and wireless sensors, I/O modules, RXT-320 transceiver, CXT and/or CX analog inputs and automatically sets their configuration parameters. All configuration inputs are completely field-configurable which provides a distinctive combination of user configuration flexibility and expansion customization.

The controller utilizes touch screen technology that displays the status of every sensor, with more detailed information available at a touch of the screen. Typical sensor status includes channel number, tag name, gas type, concentration, and alarm/fault status. Each channel provides three alarm levels (Alarm 1, Alarm 2, and Alarm 3) and fault. Additional features include: one-touch Alarm Inhibit, Alarm Reset, and Alarm Silence (Acknowledge) functions.

The MCX-32 controller can be powered by 100-120/220-240VAC 50~60Hz, 19.2-28.8VDC, or both and is available in two enclosure types. These enclosure types are NEMA 1 (N1P) and NEMA 4X (N4X). The N1P is an indoor use, panel-mount enclosure while the N4X is an indoor/outdoor use, water/corrosion proof enclosure. These enclosure types are discussed in more detail in their respective installation sections.

1.2 Wireless Option

The MCX-32 offers a wireless option using Detcon's RXT-320 wireless transceivers and CXT wireless sensors. These wireless devices convert wired Modbus communications to a wireless platform which broadcasts information throughout a network of wireless devices. Wireless applications can be a single field device communicating with the MCX-32 or multiple field devices forming a network of subscribers. Each device in the network is assigned a unique Modbus address and all wireless devices in the network must reside on the same RF channel and Network ID. For multiple networks, each network must be placed on its own RF channel/Network ID.

NOTE: Each device in a network (wired or wireless) must have a unique Modbus address. All wireless devices in a network must reside on the same RF channel/Network ID. Multiple networks must reside on different RF channels/Network IDs.

If radio communication is limited due to distance or obstruction, each wireless device is capable of locating an alternate route and repeating broadcast communications. So using an additional, properly placed radio can extend range or re-route around obstructions. Thus, this innovative technology is designed to create a robust network that automatically routes around congestion and line-of-sight obstacles while improving throughput as subscriber device density increases. Detcon’s RXT and CXT devices utilize radios based upon the IEEE 802.15.4 standard that operate at 2.4 GHz and conform to non-licensed radio frequency usage worldwide. Spread spectrum technology supports integrity and security for the wireless network. Refer to the RXT-320 Wireless Transceiver manual for more detailed information.

The RXT-320 wireless transceiver used with the MCX-32 is packaged in a black ABS box (Figure 1) that is DIN rail mounted in the enclosure. A separate transceiver is required for each communication port (network) to be used. There is an accessible rotary switch SW1 located on the box that enables selection of the desired RF channel/Network ID for the corresponding communication port. The RF channel and Network ID are married via the switch so the value selected represents both the RF channel and Network ID. For example, if the SW1 rotary switch is set to a value of 3 then the RF channel is 3 and Network ID is 3. A total of 16 RF channels can be selected ranging from hex values 0 thru F which correspond to decimal values 0 thru 15.

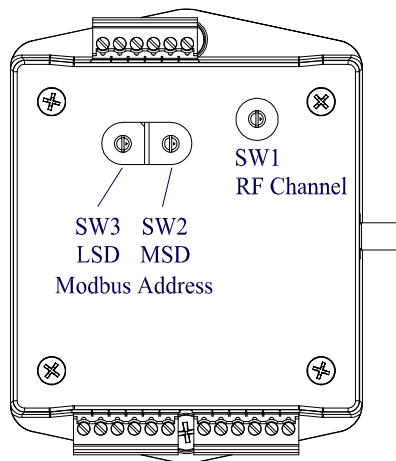

Figure 1 MCX-32 Wireless Transceiver

There are also two rotary switches SW2 and SW3 used to select the Modbus address corresponding to the specific controller port that the transceiver is interfaced to. SW2 represents the most significant digit (MSD) and SW3 represents the least significant digit (LSD). For the master communication ports PORT1 and PORT2, the Modbus address must be hex value ‘F0’ where ‘F’ is the MSD and ‘0’ is the LSD. If the transceiver is interfaced to the slave communication port PORT3, then the Modbus address is set to hex value ‘00’ so that the transceiver functions in transparent mode and allows another controller/remote display to access the MCX’s internal slave Modbus address (Reference section 5.4.5.4 Modbus Address Screen).

For NEMA 1 or NEMA 12 units the antenna is typically mounted separately, using Detcon’s remote antenna mounting kit. On NEMA 4 units the antenna can be installed on the top of the enclosure or separated up to 50m using Detcon’s remote antenna mounting kit (Section **Error! Reference source not found.**). Detcon’s antennas are vertically polarized. This means that there is an RF ‘Dead-Zone’ directly above and below any transmitting antenna. Because of this, any device with an antenna that is located near an elevated antenna should be placed at least as far from the elevated antenna as the antenna is high. For example, if an antenna is 20ft. off the ground, the nearest antenna should be at least 20 ft. away.

1.3 System Operation

The heart of the MCX-32 controller is the backlit touch screen LCD display. The controller communicates with serial sensors, I/O modules and wireless transceivers using RS-485 Modbus™ RTU Protocol. The MCX-32 includes two separate Modbus™ ports. These ports are used to communicate directly with Modbus™ capable sensors, wireless transceivers or Detcon's I/O Modules. The two ports will also provide 24VDC power at up to 3Amps combined. This is typically enough power for up to 32 sensors, any associated wireless transceivers and input modules, and up to 4 alarm modules. (Alarms are controlled by Detcon's RL-4 Modules. For more than 32 sensors, an additional power supply mounted in a separate enclosure is available.) An optional third port is available for use with remote monitors or displays.

NOTE: The power supply for the Model MCX-32 controller can power up to a maximum of 32 sensors and any associated wireless transceivers and I/O modules even though the controller is capable of communicating with up to 64 devices. An additional power supply will be required if powering more than 32 sensors.

The number of I/O modules supported by the MCX-32 controller will vary depending on the enclosure type chosen due to physical space limitations. A maximum of 2 I/O modules will fit on the outside of the MCX-32-N1P enclosure and a maximum of 16 I/O modules will fit inside the MCX-32-N4X enclosure. With the wireless option, the number of I/O modules allowed inside the enclosure will significantly decrease due to the additional space required for the RXT-320 wireless transceivers. I/O modules are individually addressable, operate on 24VDC, and are normally factory installed unless specifically instructed otherwise. Any additional modules will have to be mounted in a separate enclosure by the customer. I/O modules are purchased separately.

The available Detcon I/O modules include:

Model DA-4 – Four Channel 4-20mA Input Module
Model DI-4 – Four Channel Dry Contact Input Module
Model AO-4 – Four Channel 4-20mA Output Module
Model RL-4 – Four Alarm Relay Output Module

The controller is capable of communicating directly with the Detcon 100, 600C, 600D and 700 series sensors as well as I/O modules. With the wireless option, the controller can also communicate with RXT and CXT wireless sensors and devices. Communication via Modbus™ provides the controller enough information to identify a sensor or device and obtain details on its operation. These details are used to populate the Details Screen for that sensor/device. This Auto Configuration capability allows the controller to start a polling sequence that will identify 100, 600D, 600C, 700, CXT320, RXT320 series sensors/devices and I/O Modules and identify the type of device, the range and current conditions of the device.

NOTE: The controller provides the option to automatically configure or manually configure channels when using Detcon 100, 600D, 600C, 700, CXT320, RXT320 series sensors/devices and I/O Modules.

1.3.1 Interface PCA

The Interface PCA is the primary support for the touch screen controller. This PCA is the interface between the Touch Screen Controller's RS-232 ports and the RS-485 Modbus™ ports. These RS-485 ports include RS-485 Ports 1 and 2, and the remote port used for communication with the Remote Display (optional). The PCA monitors the 24VDC, and controls switching between the primary internal 24V Power supply, and a secondary external 24V power source. When a battery (or set of batteries) is connected to the secondary

24VDC input, the Interface PCA can provide a charging voltage for the battery if the charging circuitry is enabled on the PCA. The Interface PCA also includes two auxiliary relays for Fault and No-Comm.

1.3.2 Communication Ports

To communicate efficiently with up to 64 sensors/devices and a compliment of I/O Modules, the MCX-32 utilizes three communications ports:

1. Port 1 is utilized for direct communication with channels 1-32 of Modbus™ capable sensors and supports all Detcon I/O modules associated with those channels.
2. Port 2 is utilized for direct communication with channels 33-64 of Modbus™ capable sensors and supports all Detcon I/O modules associated with those channels.
3. Port 3 is utilized as a Modbus™ slave port and is labeled 'RS-485 REMOTE'. It is typically used for Remote Displays.

If Modbus™ devices are attached to the MCX-32 they must be installed and configured as follows:

- Each device must be addressed correctly to be recognized on the Modbus™.
- Directly addressable Modbus™ capable sensors must be connected to the correct port for proper communication.
- The correct I/O type must be configured in the Channel Details screen.
- RL-4 modules and Alarm Stations must be identified on the RL-4/Alarm Station Setup screen.
- For the wireless option, each port requires a separate RST-320 transceiver and each transceiver must be set to a separate RF channel/Network ID.

1.3.3 Auxiliary Relays

The Interface PCA contains two relays that can be configured and used for contact closure outputs for 'FAULT' and 'NO-COMM' errors. The Fault Relay is set whenever there is a sensor fault, and the No-Comm relay is set when there is a 'no communication' error. These relays are configurable as to how they will be set when a fault or 'no communication' error occurs. The relays may be configured as Energized or De-energized, Silenceable or Non-Silenceable, and Latched or Unlatched. This allows a great deal of flexibility for setting these relays up as needed. Refer to Section 5.4.8.

1.3.4 Auxiliary 24VDC input

The MCX-32 has the ability to operate on the internal 24VDC power supply, or on the auxiliary 24VDC input. This auxiliary 24VDC input can be an external 24VDC power source, a battery backup unit, or it can be directly wired to a set of batteries. The input source (rated at 19.2 to 28.8VDC) should be capable of delivering up to 5Amps continuous current. The Interface PCA will monitor both the primary internal 24VDC power supply, and the secondary auxiliary 24VDC input. Should the primary internal 24VDC power supply stop functioning or fall below 18VDC, and the secondary auxiliary 24VDC input is still operational, the controller will automatically switch to the secondary input.

If batteries are connected to the auxiliary 24VDC input, the Interface PCA has the unique ability to provide a nominal 27VDC at 1Amp specifically for charging the batteries. This voltage is only to be used for charging batteries. Damage may result if this charging voltage is enabled and the input voltage source is not batteries (See Section 5.4.5.6).



WARNING: Switching the secondary from DC POWER to BATTERY with a hard line DC power source connected to the Auxiliary 24VDC Input may result in damage to the MCX-32 and other electronic equipment. Do not change the secondary source to BATTERY unless batteries are

connected to the controller.

1.4 Programming Configuration

The MCX-32 controller can be configured for various I/O combinations at the Detcon factory based on application specific information provided by the customer on the Configuration Form. It must be verified that the correct quantity and type of I/O modules and wireless transceivers have been purchased to support the customer’s configuration requirements. On the Configuration Form, the customer should supply all site-specific information:

- 1) Wireless requirements for wireless option
- 2) Number of gas/sensor channels
- 3) Detcon sensor model number and I/O type (Modbus™ or 4-20mA) for each channel
- 4) Range, units, and gas type for each channel
- 5) Alarm level(s) for each gas channel
- 6) Tag Name for each channel
- 7) Assignment and set-up information for each relay contact
- 8) Analog output requirements for each channel

NOTE: The set-up configuration is fully field-programmable and can be executed by the user in the field. Refer to Section 6.0 Controller Setup. Modifications to the set-up configuration are expected to take place at the customer’s site due to requirement changes and/or system expansions.

2.0 Installation

2.1 Safety Guidelines

If equipment is used in a manner not specified by Detcon, the protection provided by the equipment may be impaired.



CAUTION

The user must consult this manual for more information about any location marked with this symbol.



DANGER

Danger of electrical shock. User must ensure that power has been disconnected prior to installation or servicing of the equipment.



**PROTECTIVE
EARTH
TERMINAL**

This symbol identifies a terminal that is the connection point for a protective earth conductor. Only the protective earth conductor should be connected here.



**FUNCTIONAL
EARTH
TERMINAL**

This symbol identifies a terminal that provides an earth ground reference point. These terminals are not for safety earthing purposes.

2.2 N1P and N1R Enclosure Installation

2.2.1 Mounting and Cable Installation

The Model MCX-32-N1P controller is housed in a NEMA 1 panel mount enclosure for indoor use. Securely mount the Model MCX-32-N1P per the mounting dimensions provided in Figure 2. The enclosure is designed to fit a panel opening of 9.25" wide by 7.5" high. Keep AC power separate from DC power and signals within conduit runs.

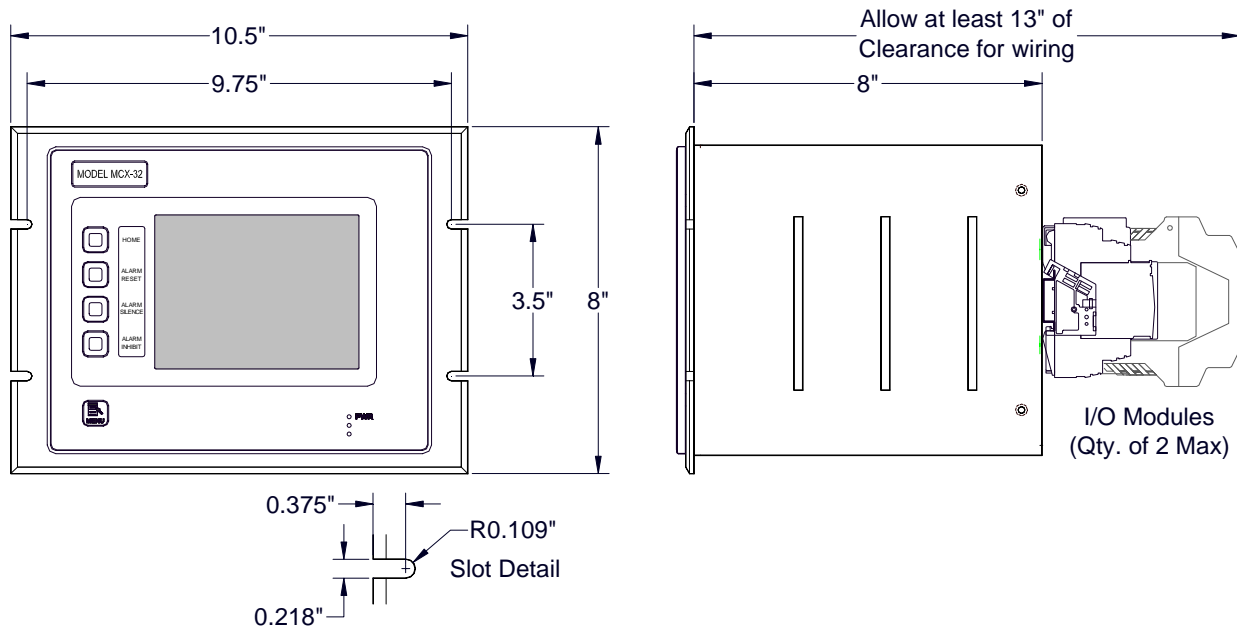

Figure 2 MCX-32-N1P Controller Mounting and Dimensional

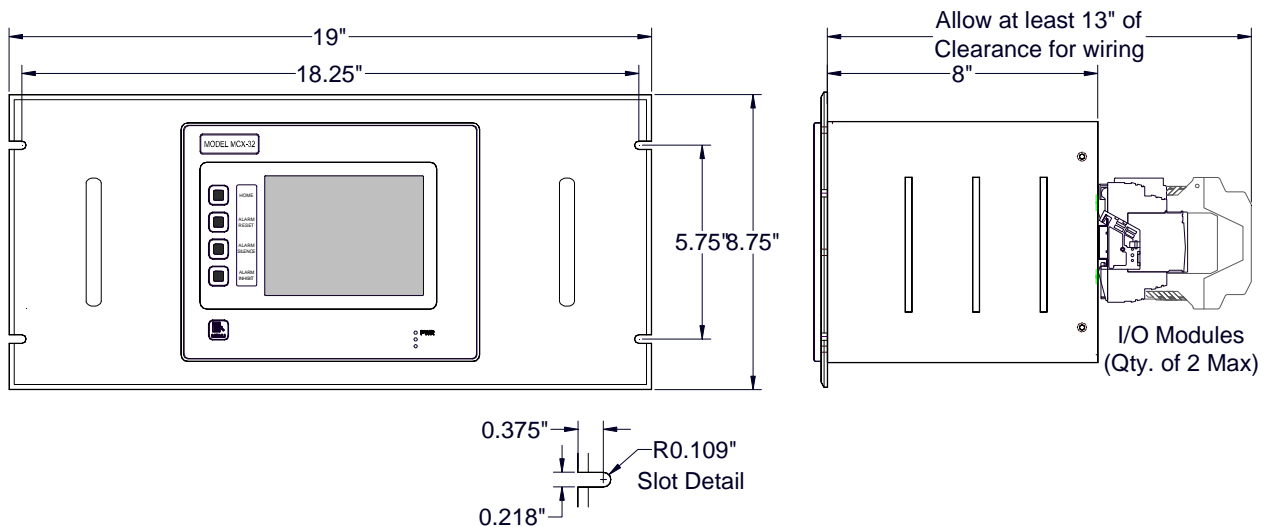

Figure 3 MCX-32-N1R Controller Mounting and Dimensional

2.2.2 Power Connections

The Model MCX-32-N1P controller can be powered by either 100-120/220-240VAC, 19.2-28.8VDC or both. The unit is equipped with an internal 24VDC 5Amp universal power supply that operates on 100-120/220-

240VAC that can power up to 32 sensors and any associated I/O modules. The MCX-32 controller can also be powered by an external DC source that meets the input requirements of the unit if AC power is not available or desired.

NOTE: The power supply for the MCX-32-N1P controller can power up to a maximum of 32 sensors and any associated I/O modules even though the controller is capable of communication with up to 64 sensors. An additional power supply will be required if powering more than 32 sensors.

NOTE: The MCX-32-N1P controller can accommodate only 2 I/O modules. Any additional modules required will need to be mounted in a separate enclosure by the customer.

2.2.3 AC Power

Connect 100-120/220-240VAC input wiring to the terminals located on the back of the enclosure, labeled “VAC (L1)”, “NEU (L2)”, and “GROUND” (See Figure 4). The power supply for the MCX-32-N1P is capable of handling AC inputs from 100-120/220-240VAC, 50-60Hz without degradation.

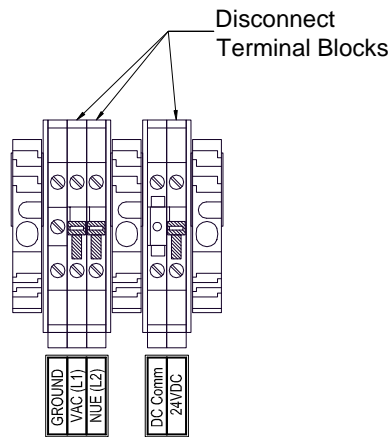

Figure 4 AC/DC Inputs

NOTE: The input AC voltage range must be between 100-120/220-240VAC 50~60Hz.

2.2.4 DC Power

For optional external DC power input, connect 19.2-28.8VDC to the terminals located on the back of the enclosure, labeled “24VDC” and “DC Comm” (See Figure 4). This input can be used for primary power or back-up power in the event of an AC power failure. The DC input voltage should be capable of delivering at least 5 Amps of current to the load (120 Watts @ 24VDC). This voltage can come from an external 24VDC supply or a battery back-up. If batteries are directly connected to this input, the unit has the ability to provide the necessary battery charging voltage to the batteries. See Section 5.4.5.6 Power Management Screen for setting up the charging voltage for the batteries.

NOTE: The supply of power should be from an isolated source with over-current protection as applicable. The input voltage range must be between 19.2-28.8VDC.

2.3 N4X Enclosure Installation

2.3.1 Mounting and Cable Installation



CAUTION

The wall attachments must be able to withstand a force four times the weight of the equipment.



CAUTION

The MCX-32 must be mounted in a location that does not impair the operation of the external disconnection device.

The Model MCX-32-N4X controller is housed in a NEMA 4X water/corrosion proof enclosure for indoor/outdoor use. The controller includes gland plates on both the top and bottom of the enclosure. These gland plates should be used to mount conduit hubs or cable glands used for wiring the controller. The controller is configured to incorporate conduit and conduit hubs for running cables. Securely mount the Model MCX-32-N4X per the mounting dimensions provided in Figure 5. Keep AC power separate from DC power and signals within conduit runs.

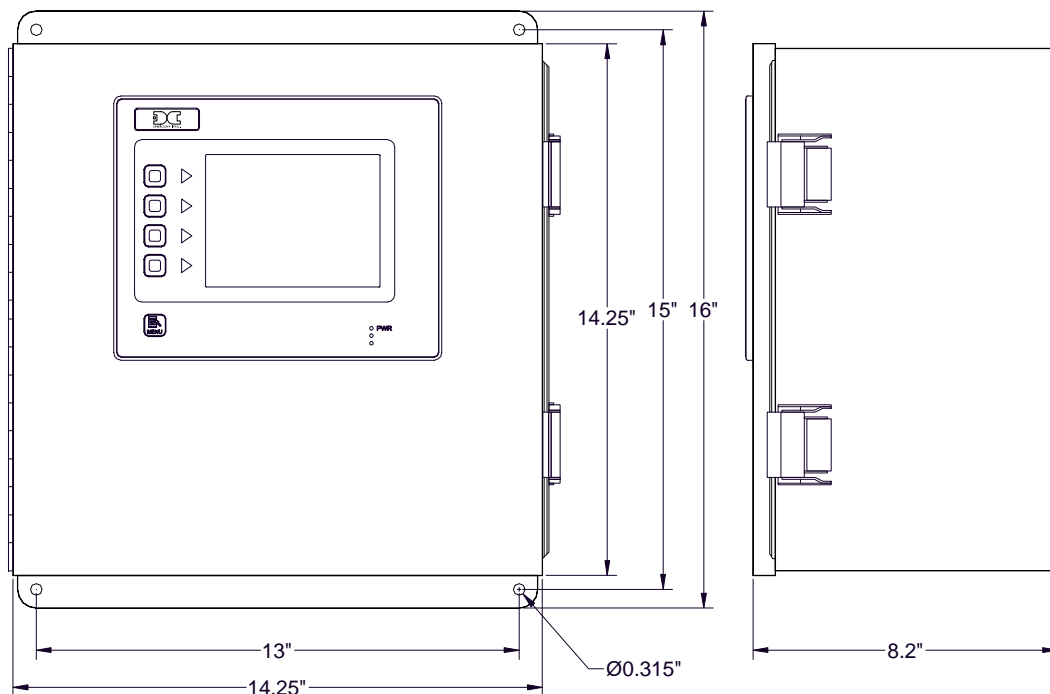

Figure 5 MCX-32-N4X Controller Mounting and Dimensional View

2.3.2 Power Connections

The Model MCX-32-N4X controller can be powered by either 100-120/220-240VAC, 19.2-28.8VDC or both. An internal power supply is available for the MCX-32-N4X that converts 110/220VAC to 24VDC (up to 5Amps) and can power up to 32 sensors and any associated I/O modules and wireless transceivers. The MCX-32 controller can also be powered by an external DC source that meets the input requirements of the unit if AC power is not available or desired.

NOTE: The power supply for the MCX-32-N4X controller can power up to a maximum of 32 sensors and any associated I/O modules and wireless transceivers even though the controller is capable of communication with up to 64 devices. An additional power supply will be required if powering more than 32 sensors.

NOTE: The MCX-32-N4X controller can accommodate up to 16 I/O modules without the wireless option. The wireless option will decrease the number of modules able to fit in the enclosure due to the additional space required by the wireless transceiver boxes. Any additional modules required will need to be mounted in a separate enclosure by the customer.

2.3.3 AC Power

Install the AC power as follows:

1. Connect 100-120/220-240VAC input wiring to the terminals labeled “VAC (L1)”, “NEU (L2)”, and “GROUND” (See Figure 4). The power supply for the MCX-32-N4X is capable of handling AC inputs from 100-120/220-240VAC, 50-60Hz without degradation.

NOTE The cable penetration for the AC power must be made in the bottom of the enclosure (See Figure 7). All penetrations must use conduit or a NEMA4 rated cable gland (Appleton p/n CG-2575 or equivalent) to prevent water ingress and restrict access to the internal circuits of the MCX-32.

- a. Locate the ground terminal on the pack plate of the N4X enclosure (Figure 6).
- b. Remove both nuts and the internal ground conductor
- c. Connect the protective earth conductor to the ground terminal with one lock washer, the protective earth conductor, a second lock washer on top of the conductor, a nut on top of the conductor, the circuit ground connector, and then a nut.

NOTE Ensure that the protective earth conductor is connected directly to the ground terminal.

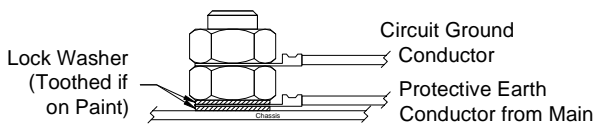

Figure 6 N4X Protective Earth Connector

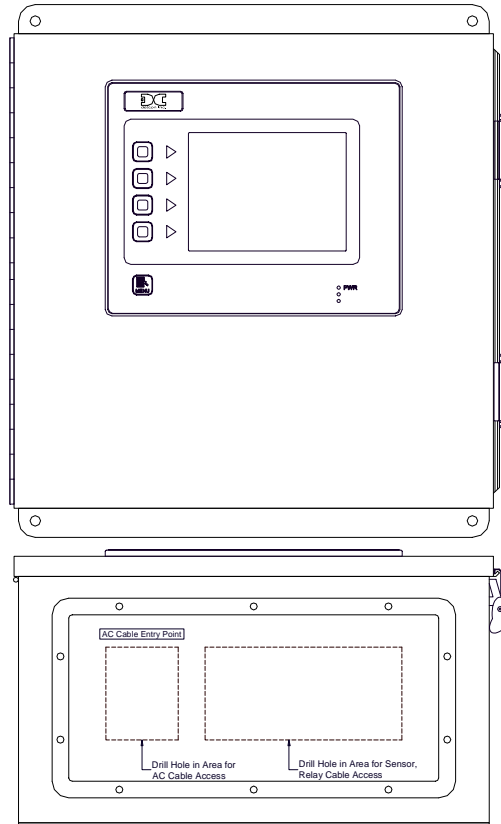

Figure 7 Cable Entry Points

2. Tie the AC power conductors together with a tie-wrap.
3. To maintain the safety approval for the MCX-32, the user must install a circuit breaker near the MCX-32 so that it can be easily reached and labeled as the disconnection device for the MCX-32. The installed AC circuit breakers should be rated for 5A.

NOTE

The equipment switch or circuit-breaker employed as a disconnecting device shall meet the relevant requirements of IEC 60947-1 and IEC 60947-3 and be suitable for the application. Internal Disconnect Terminal Blocks are provided for the removal of power at the unit when needed.



CAUTION

Equipment and equipment to be electrically connected shall use safety approved wire/cable in conjunction with appropriate and compatible protective cable gland, all of which meet the requirements of the max equipment rating (250VAC, 5A) and any local electrical codes, regulations and standards. The cable used to connect to the terminals of the MCX-32-N4X must be rated for a minimum of 105°C.

2.3.4 DC Power

For optional external DC power input, connect 19.2-28.8VDC to the terminals labeled “24VDC” and “DC Comm” (See Figure 4). This input can be used for primary power or back-up power in the event of an AC power failure. The DC input voltage should be capable of delivering at least 5 Amps of current to the load (120 Watts @ 24VDC). This voltage can come from an external 24VDC supply or a battery back-up. If batteries are directly connected to this input, the unit has the ability to provide the necessary battery charging

voltage to the batteries. See Section 5.4.5.6 Power Management Screen for setting up the charging voltage for the batteries.

NOTE: The supply of power should be from an isolated source with over-current protection as applicable. The input voltage range must be between 19.2-28.8VDC.

1. Install the DC power as follows:
 - a. Install external DC power by connecting the 19.2-28.8VDC to the terminals of the TB1 DIN rail mounted terminal block labeled **24VDC** and **DC Comm** (Figure 8). The equipment supply wiring must be safety approved and rated for at least 5A.

NOTE The cable penetration for the DC power must be made in the bottom of the enclosure (See Figure 7). All penetrations must use conduit or a NEMA4 rated cable gland (Appleton p/n CG-2575 or equivalent) to prevent water ingress and restrict access to the internal circuits of the MCX-32.

- b. To maintain the safety approval for the MCX-32, the user must install an external disconnect switch or circuit breaker near the MCX-32 so that it can be easily reached and labeled as the disconnection device for the MCX-32. The installed DC circuit breaker should be rated for 5A. Internal Disconnect Terminal Blocks are provided for the removal of power at the unit when needed.

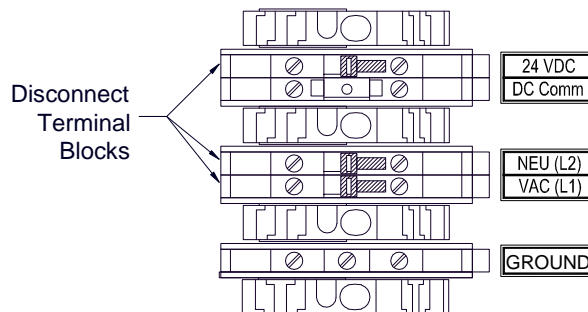

Figure 8 N4X AC/DC Inputs

3.0 I/O Connections

There are two distinct RS-485 ports utilized in the MCX-32 controller labeled “RS-485 PORT1” and “RS-485 PORT2” (See Figure 9). These ports can be utilized for wired sensors, I/O Modules and wireless transceivers. Each port has three discrete input terminals labeled “A”, “B” and “Shld” corresponding to the RS-485 wiring. Also available are two output terminals that provide 24VDC power to external RS-485 devices. RS-485 wiring with power should consist of a two conductor, shielded twisted pair for RS-485 and two conductor power (General Cable Commadore p/n ZO16P0022189 is recommended). The 24VDC power should be used only to power remotely located I/O modules and/or sensors, and should not exceed 3 Amps accumulative for all I/O modules and sensors attached to the controller. (i.e. if there are two modules mounted in the enclosure that have an accumulative current draw of 0.5Amps, the sensors and/or I/O modules connected to the output 24VDC should not exceed 2.5Amps.) Refer to the manuals for each module and sensor for the maximum expected current draw from each device.

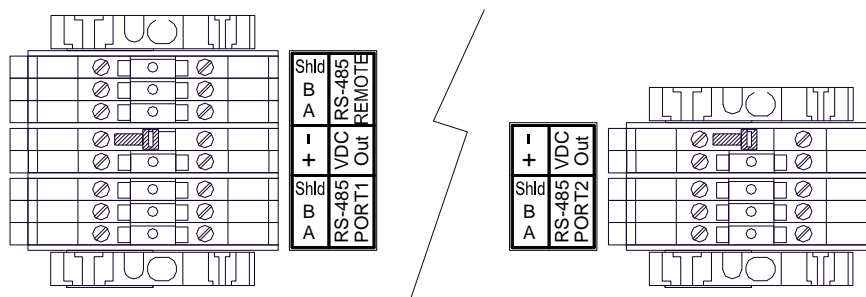

Figure 9 RS-485 Wiring Terminals for PORT1, PORT2 and REMOTE

WARNING: Do not attach more devices to the controller power supply than the power supply has the capacity for, as damage may occur to the controller and will void the warranty. The capacity is 3Amps maximum. Modules and sensors attached to the controller that exceed this rating should be powered by an external power supply capable of handling the extended load.

If the MCX-32 controller was ordered with the wireless option, the radio module is installed in the enclosure and an antenna connector is provided on the top of the enclosure. Mount the external antenna in an appropriate location with an unobstructed line-of-sight to the wireless devices. Connect the RF cable from the connector on top of the MCX-32 to the antenna.

! Any slave device near an elevated or remote mounted antenna needs to be at least as far from the antenna as the antenna is high. For example, if the antenna is 20ft. high, then the nearest slave device should be at least 20 ft. away.

If the Remote Display option is installed, a set of terminals labeled “RS-485 REMOTE” is available for connection to a remote display (Figure 9). If a remote display is included in the system configuration, connect the RS-485 cable from the Remote Display to these terminals. For a wireless remote display, a wireless transceiver black box will be factory installed and interfaced to these terminals.

3.1 Analog 4-20mA Sensor Inputs (DA-4)

Connect 4-20mA type gas sensors to Model DA-4 4-20mA input modules. The DA-4 modules provide power to any 2-wire or 3-wire field sensor and receives standard 4-20mA signal inputs from the sensors (Figure 10).

NOTE The terminals on the DA-4 module are rated for a maximum of 30VDC. They are designed to accept solid or stranded wire between 12AWG and 24AWG.

-
- NOTE** Analog sensors used with the MCX-32 must supply 4mA for a zero reading and 20mA for a full scale reading. The sensors current output should be linear for readings between zero and full scale. Sensors that do not meet this requirement must not be used with the MCX-32.
-
- NOTE** External devices attached to the equipment must require a tool to access their wiring terminals to prevent unauthorized access.
-
- NOTE** Hazardous live voltages of external devices attached to the DA4 must be isolated or disconnected prior to accessing the terminals of the external devices
-
- NOTE** All cable penetrations for analog sensor cables must be made in the bottom of the enclosure (See Figure 7). All penetrations must use conduit or a NEMA4 rated cable gland (Appleton p/n CG-2575 or equivalent) to prevent water ingress and restrict access to the internal circuits of the MCX-32.
-

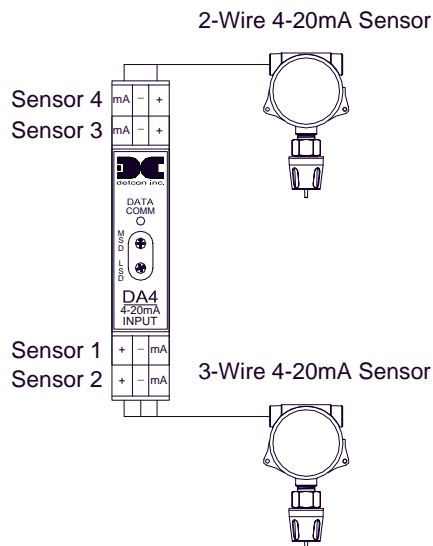

Figure 10 Model DA-4 4-20mA Input Module and 4-20mA Gas Sensor Connections

There are four 4-20mA inputs with each DA-4 module to support up to four sensors (See Figure 11). DA-4 modules can be installed on the DIN rail of the controller. DA-4 modules can be connected to either Port 1 or Port 2 of the controller.

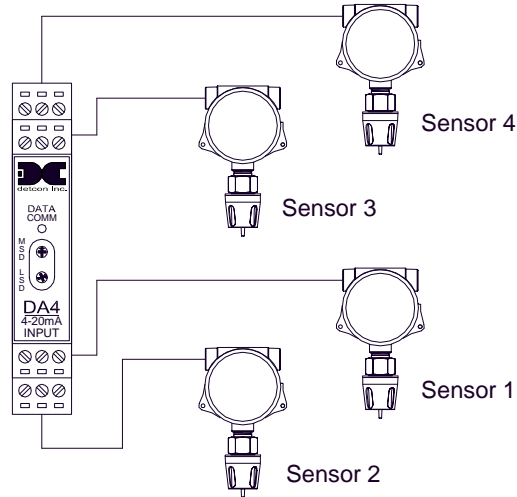

Figure 11 Model DA-4 4-20mA Input Module and 4-20mA Gas Sensors

Table 1 DA-4/DI-4 Modbus Addresses

Port	Module	Channel #	Decimal	Hex	Module	Channel #	Decimal	Hex	
1	1	1	64	40	5	17	68	44	
		2				18			
		3				19			
		4				20			
	2	2	5	65	41	6	21	69	45
			6				22		
			7				23		
			8				24		
	3	3	9	66	42	7	25	70	46
			10				26		
			11				27		
			12				28		
	4	4	13	67	43	8	29	71	47
			14				30		
			15				31		
			16				32		
2	9	33	72	48	13	49	76	4C	
		34				50			
		35				51			
		36				52			
	10	10	37	73	49	14	53	77	4D
			38				54		
			39				55		
			40				56		
	11	11	41	74	4A	15	57	78	4E
			42				58		
			43				59		
			44				60		
	12	12	45	75	4B	16	61	79	4F
			46				62		
			47				63		
			48				64		

The 4-20mA signals from the sensors are communicated by the DA-4 modules to the controller using RS-485 Modbus™ RTU protocol. Therefore, each DA-4 module must have a unique Modbus™ address. Modules are serially addressed in hex using the two rotary switches on the module’s front panel labeled MSD (most significant digit) and LSD (least significant digit). Each DA-4 module will have four channels reserved based on its Modbus address with each channel corresponding to each of its four inputs. The DA-4 modules must be addressed according to Table 1 DA-4/DI-4 Modbus Addresses.

A DA-4 module connected properly to the controller will have a flashing DATA COMM LED to indicate a valid communication status and will provide the controller with a continuous reading of the sensor attached. All other information will need to be modified on the Channel Details screen for each channel corresponding to the appropriate DA-4 module.

NOTE: DA-4 modules can be connected to either Port 1 or Port 2, they must be addressed correctly and only those channels associated with that DA-4 will be available. During an Auto Configure, only DA-4 inputs with an active 4-20mA signal will be recognized.

For manual configuration, set the desired Modbus address for the DA-4 module, enable the corresponding channels to be used and modify the information on the Channels Details screen to reflect the correct sensor type and information. Setting up a DA-4 should start by selecting the ‘Device Type’ from the Channel Details screen, and selecting “DA4” from the ‘DEVICE SELECTION’ screen. If the controller does not detect a DA-4 module, the controller will display “COMM ERR” in the ‘Status’ field. A properly addressed DA-4 that is correctly connected to the controller will respond to channel activation with a concentration reading. When the controller has detected the DA-4, the gas type will default to H2S, the range will default to 100, and the analog out will default to ‘OFF’. Once the DA-4 has been properly detected, all of the information needed to identify the sensor can be entered in the Channel Details screen to set the correct parameters for the sensor.

3.2 Dry Contact Inputs (DI-4)

Relay contact outputs from field devices can be connected to Model DI-4 input modules. There are four relay contact inputs in each Model DI-4 module (See Figure 12). DI-4 modules can be installed on the DIN rail of the controller. DI-4 modules can be connected to either Port 1 or Port 2 of the controller.

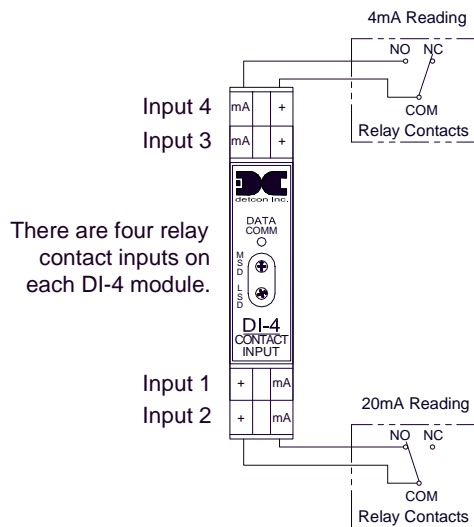

Figure 12 Model DI-4 Contact Input Module

NOTE The terminals on the DI-4 module are rated for a maximum of 30VDC. They are designed to accept solid or stranded wire between 12AWG and 24AWG.

NOTE	External devices attached to the DI4 outputs must require a tool to access their wiring terminals to prevent unauthorized access.
-------------	---

NOTE	Hazardous live voltages of external devices attached to the equipment must be isolated or disconnected prior to accessing the terminals of the external devices
-------------	---

NOTE	The cable penetrations for the dry contact inputs must be made in the bottom of the enclosure (See Figure 7). All penetrations must use a NEMA4 rated cable gland (Appleton p/n CG-2575 or equivalent) to prevent water ingress and restrict access to the internal circuits of the MCX-32.
-------------	---

The state of the contact outputs from field devices are communicated by the DI-4 modules to the controller using RS-485 Modbus™ RTU protocol. Therefore, each DI-4 module must have a unique Modbus™ address. Modules are serially addressed in hex using the two rotary switches on the module's front panel labeled MSD (most significant digit) and LSD (least significant digit). Each DI-4 module will have four channels reserved based on its Modbus address with each channel corresponding to each of its four inputs. The DI-4 modules must be addressed according to Table 1 DA-4/DI-4 Modbus Addresses.

A DI-4 module connected properly to the controller will have a flashing DATA COMM LED to indicate a valid communication status and will provide the controller with a 4mA reading when the contact from the field device is open and a 20mA reading when the contact is closed for the corresponding channels. All other information will need to be modified on the Channel Details screen for each channel corresponding to the appropriate DA-4 module.

NOTE: DI-4 modules can be connected to either Port 1 or Port 2, they must be addressed correctly and only those channels associated with that DI-4 will be available. During an Auto Configure, all DI-4 inputs will be recognized.

For manual configuration, set the desired Modbus address for the DI-4 module, enable the corresponding channels to be used and modify the information on the Channels Details screen to reflect the correct sensor type and information. Setting up a DI-4 should start by selecting the 'Device Type' from the Channel Details screen, and selecting "DI4" from the 'DEVICE SELECTION' screen. If the controller does not detect a DI-4 module, the controller will display "COMM ERR" in the 'Status' field. A properly addressed DI-4 that is correctly connected to the controller will respond to channel activation with a mA reading. When the controller has detected the DI-4, the gas type will default to H2S, the range will default to 100, and the analog out will default to 'OFF'. Once the DI-4 has been properly detected, all of the information needed to identify the sensor can be entered in the Channel Details screen to set the correct parameters for the sensor.

3.3 Analog 4-20mA Outputs (AO-4)

There are four 4-20mA outputs in each Model AO-4 module (See Figure 13). These can be used as signal inputs to other control devices. AO-4 modules can be installed on the DIN rail of the controller.

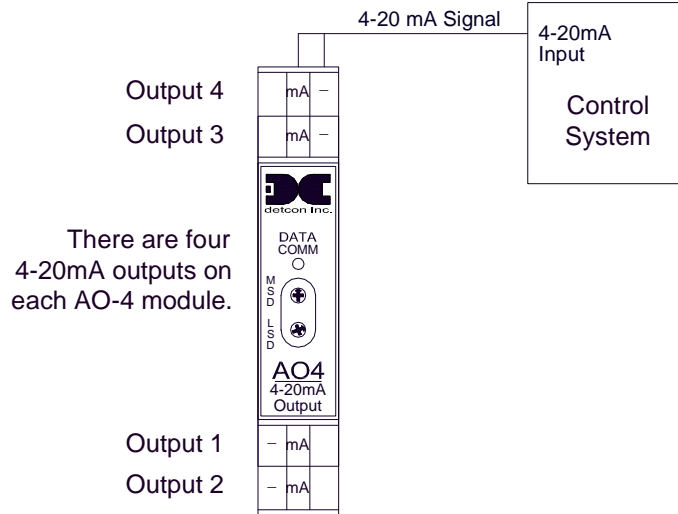

Figure 13 Model AO-4 4-20mA Output Module

NOTE The terminals on the AO-4 module are rated for a maximum of 30VDC. They are designed to accept solid or stranded wire between 12AWG and 24AWG.

NOTE External devices attached to the equipment must require a tool to access their wiring terminals to prevent unauthorized access.

NOTE Hazardous live voltages of external devices attached to the AO4 must be isolated or disconnected prior to accessing the terminals of the external devices

NOTE The cable penetration for the analog outputs must be made in the bottom of the enclosure (See Figure 7). All penetrations must use conduit or a NEMA4 rated cable gland (Appleton p/n CG-2575 or equivalent) to prevent water ingress and restrict access to the internal circuits of the MCX-32.

AO-4 modules provide a 4-20mA output equal to the current concentration reading reported to the controller for the associated channel. These concentration readings are communicated by the controller to the AO-4 modules using RS-485 Modbus™ RTU protocol. Therefore, each AO-4 module must have a unique Modbus™ address. Modules are serially addressed in hex using the two rotary switches on the module’s front panel labeled MSD (most significant digit) and LSD (least significant digit). AO-4 modules can be connected to either Port 1 or Port 2 of the controller. For the controller to recognize the modules, the ‘Analog Out’ on the Channel Details screen must be turned ‘ON’ for the specific channels associated to the AO-4 modules. The AO-4 modules must be addressed according to Table 2 AO-4 Modbus™ Addresses.

As an example, assume all 64 channels from the MCX-32 have sensors configured to them and the sensor reading of channel 39 is wanted as an input to another control device. First note that channel 39 corresponds to module 10 in Port 2 with hex address A9 per Table 2. Therefore, an AO-4 module set to hex address A9 would need to be installed in Port 2 of the MCX-32. Next, the ‘Analog Out’ on the Channel Details screen for channel 39 would need to be turned ‘ON’. The MCX-32 would now be able to recognize the AO-4 module and the module’s DATA COMM LED would blink intermittently, indicating a valid communication status.

The AO-4 module would output a 4-20mA signal on its output 3 (Figure 13) corresponding to channel 39's reading.

Table 2 AO-4 Modbus™ Addresses

Port	Module	Channel #	Decimal	Hex	Module	Channel #	Decimal	Hex	
1	1	1	160	A0	5	17	164	A4	
		2				18			
		3				19			
		4				20			
	2	2	5	161	A1	6	21	165	A5
			6				22		
			7				23		
			8				24		
	3	3	9	162	A2	7	25	166	A6
			10				26		
			11				27		
			12				28		
	4	4	13	163	A3	8	29	167	A7
			14				30		
			15				31		
			16				32		
2	9	33	168	A8	13	49	172	AC	
		34				50			
		35				51			
		36				52			
	10	10	37	169	A9	14	53	173	AD
			38				54		
			39				55		
			40				56		
	11	11	41	170	AA	15	57	174	AE
			42				58		
			43				59		
			44				60		
	12	12	45	171	AB	16	61	175	AF
			46				62		
			47				63		
			48				64		

An AO-4 module connected properly to the controller will have a flashing DATA COMM LED to indicate a valid communication status and will provide a 4-20mA output equal to the current concentration reading reported to the controller for the associated channel.

NOTE: AO-4 modules can be connected to either Port 1 or Port 2, they must be addressed correctly, and their associated channel's 'Analog Out' must be turned 'ON' from the Channel Details screen.

After identifying the correct port and address for the AO-4 module, the 'Analog Out' must be turned 'ON' from the Channel Details screen for the specific channel corresponding to the AO-4's output. A properly addressed AO-4 that is correctly connected and configured to the controller will respond to channel activation with a 4-20mA output reading equal to the current concentration reading reported to the controller for the associated channel.

3.4 Alarm Relay Outputs (RL-4)

There are four (4) Form C Single Pole Double Throw (SPDT), 5 Amp relays in each Model RL-4 module. Each relay in the module is assigned specifically to one alarm. Relay 1 is assigned to Alarm 1, relay 2 is assigned to Alarm 2, relay 3 is assigned to Alarm 3, and relay 4 is assigned to Fault. These can be used to control (fire) annunciating devices or as signal inputs to other control devices. Connections to the relay contacts of the RL-4 module are shown in Figure 14 and are labeled C (Common), NO (Normally Open) and NC (Normally Closed). Note that the 5 Amp rating of the relay contact should not be exceeded. RL-4 modules are installed on the DIN rail of the controller.

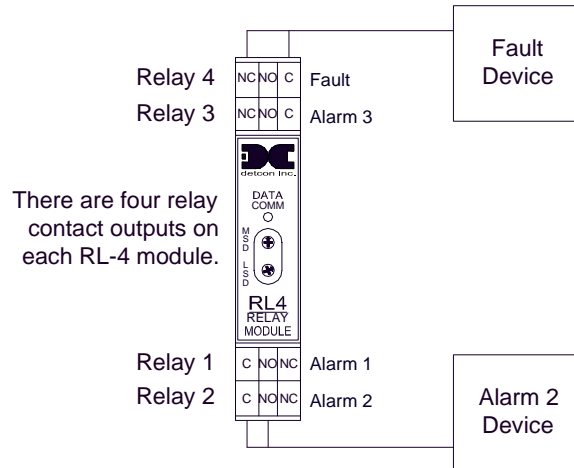

Figure 14 Model RL-4 Relay Output Module

NOTE	The terminals on the RL-4 module are rated for a maximum of 250VAC or 30VDC. They are designed to accept solid or stranded wire. Wire attached to the RL4 terminals must be safety approved and rated for at least 5A.
NOTE	The current ratings of the relay contacts, 5A @ 30VDC, 5A @ 250VAC and 5Amp rating should not be exceeded.
NOTE	External devices attached to the RL4 outputs must require a tool to access their wiring terminals to prevent unauthorized access.
NOTE	Hazardous live voltages of external devices attached to the equipment must be isolated or disconnected prior to accessing the terminals of the external devices
NOTE	The cable penetration for the relay outputs must be made in the bottom of the enclosure (See Figure 7). All penetrations must use conduit or a NEMA4 rated cable gland (Appleton p/n CG-2575 or equivalent) to prevent water ingress and restrict access to the internal circuits of the X40.

RL-4 modules provide a contact output for the associated channel. These outputs are communicated by the controller to the RL-4 modules using RS-485 Modbus™ RTU protocol. Therefore, each RL-4 module for a specific port must have a unique Modbus™ address. Modules are serially addressed in hex using the two rotary switches on the module's front panel labeled MSD (most significant digit) and LSD (least significant digit). RL-4 modules can be connected to either Port 1 or Port 2 of the controller based on the RL-4 Modbus Address Table 3. For the controller to recognize the modules, the corresponding module must be turned on in

the RL4/ALM Station Setup screen (see section 5.4.8). Once the relay modules have been addressed and installed on the Modbus™, the controller can communicate with the RL-4's. For correct communication with an RL-4, the RL-4 must have a valid address, the bank that the RL-4 is addressed in must have that RL-4 enabled in the bank, and the RL-4 must be connected to the correct port (as prescribed on the RL4 Modbus Address Table 3).

The MCX-32 controller has been configured to have sixteen separate relay banks (Bank1 thru Bank16). Each port can support up to eight banks and each bank can hold up to two RL-4 modules. Modules on Port 1 are defined by addresses 80h-8Fh and modules on Port 2 are also defined by addresses 80h-8Fh. Since Port 1 and Port 2 are independent Modbus loops, an RL4 addressed as 80h in Port 1 will NOT conflict with an RL4 addressed as 80h in Port 2 and so forth. Anytime a specific alarm is fired for a module in a bank, corresponding alarms for both modules in that particular bank are also triggered. For example, if alarm 3 of a particular module is triggered in Bank2, then alarm 3 for both modules in Bank2 will be fired. RL-4 modules can be connected to either Port 1 or Port 2 of the controller and be addressed according to the following table:

Table 3 RL-4/Alarm Station Modbus™ Addresses

Port	Bank	Module	Decimal	Hex	Bank	Module	Decimal	Hex
1	Bank 1	1	128	80	Bank 5	9	136	88
		2	129	81		10	137	89
	Bank 2	3	130	82	Bank 6	11	138	8A
		4	131	83		12	139	8B
	Bank 3	5	132	84	Bank 7	13	140	8C
		6	133	85		14	141	8D
	Bank 4	7	134	86	Bank 8	15	142	8E
		8	135	87		16	143	8F
2	Bank 9	17	128	80	Bank 13	25	136	88
		18	129	81		26	137	89
	Bank 10	19	130	82	Bank 14	27	138	8A
		20	131	83		28	139	8B
	Bank 11	21	132	84	Bank 15	29	140	8C
		22	133	85		30	141	8D
	Bank 12	23	134	86	Bank 16	31	142	8E
		24	135	87		32	143	8F

An RL-4 module connected properly to the controller will have a flashing DATA COMM LED to indicate a valid communication status and will respond to channel activation with an alarm output related to the alarm set points of the associated channel.

NOTE: RL-4 modules can be connected to either Port 1 or Port 2, they must be addressed correctly, they must be turned on and defined in the RL4/Alarm Station Setup menu, and only those RL-4's in a bank associated with a channel will be available.

Each relay within the bank can be set as Energized/De-Energized, Silenceable/Non-Silenceable, and Latching/Non-Latching (See section 5.4.2).

3.4.1 Energized or De-Energized

All alarms relays - Alarm 1, Alarm 2, Alarm 3, and Fault - can be configured to operate in either energized or de-energized mode. In de-energized mode, the normally open contact is open if the alarm level has not been

reached (alarm relays) or the sensor is not in fault (fault relay). In energized mode, the normally open contact is closed if the alarm level has not been reached (alarm relays) or the sensor is not in fault (fault relay). Energized mode provides for fail-safe operation since a loss of power or cable failure will cause the contact to be open.

3.4.2 Silenceable or Non-Silenceable

All alarms - Alarm 1, Alarm 2, Alarm 3, and Fault - can be configured to operate as Silenceable, or Non-Silenceable. If an alarm or fault is configured as Non-Silenceable, the corresponding relay, once activated, will stay activated until the cause of the alarm or fault has cleared. If an alarm or fault is configured as Silenceable, the corresponding relay, once activated, can be deactivated by pressing the Alarm Silence button on the left edge of the screen.

3.4.3 Latching or Non-Latching Relays

All alarms - Alarm 1, Alarm 2, Alarm 3, and Fault - can be configured as either latching or non-latching. In non-latching mode, the relay is deactivated as soon as the sensor alarm (alarm relays) or fault (fault relay) condition is cleared. In latching mode, the relay remains active even after the alarm or fault condition has cleared. Once activated, the relay can only be deactivated by pressing the Alarm Reset button on the left edge of the screen after the alarm or fault condition has cleared.

3.5 I/O Module Installation

The quantity of I/O modules supported by the MCX-32 controller will vary depending on the enclosure type chosen due to physical space limitations. A maximum of 2 I/O modules may be installed on the Model MCX-32-N1P enclosure. A maximum of 16 I/O modules may be installed in the Model MCX-32-N4X enclosure (Four modules can be installed on DIN rail TB1 and 12 can be installed on DIN rail TB2) without the wireless option. Additional modules will need to be mounted in a separate enclosure by the customer.

I/O modules are mounted on an industry-standard 37.5 x 7.5 mm DIN rail (See Figure 15). Install the first I/O module at the end of the DIN rail nearest the male connector. Plug the male connector into the side of the module. Slide it all the way to the end stop. Add additional modules next to the first module. When installing additional I/O modules, make sure there is about 0.5 inch clearance on either side of the module and snap the module onto the DIN rail (the 0.5" spacing is to allow for connector clearance). Once the I/O module is snapped onto the DIN rail, slide it towards the adjacent module and assure that it firmly plugs into it. Connect the RS-485 and power female connector to the last module installed on the DIN rail. Secure the modules with an end stop.

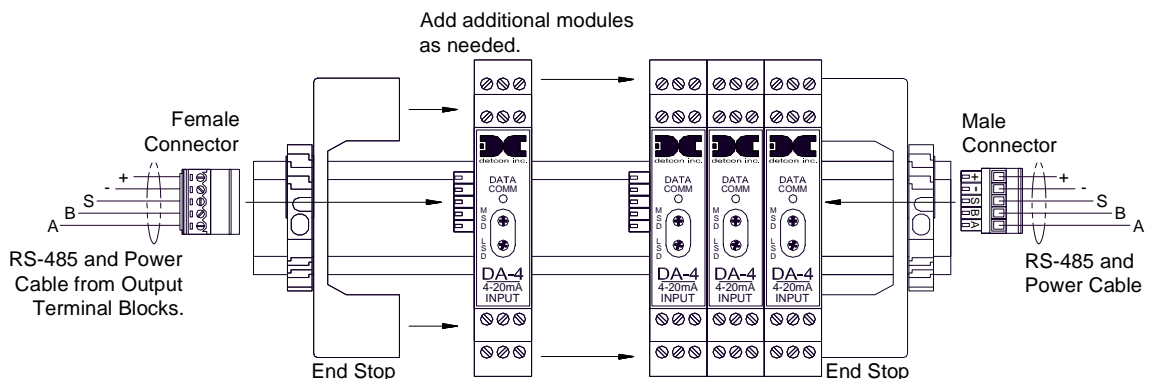

Figure 15 I/O Module Installation

NOTE: The male connector must be plugged into the I/O module at one end of the DIN rail and the female connector must be plugged into the I/O module at the other end of the stack of I/O modules. If these connectors are not properly installed, communication with other RS-485 devices will not be possible.

NOTE: If no I/O modules are installed in the controller, the male connector must be plugged into the female connector for the RS-485 to communicate.

For addressable I/O modules or Modbus™ sensors that are being located remotely from the controller, General Cable Commodore p/n ZO16P0022189 is recommended for serial and power connections.

3.6 Serial Output Gas Sensors (RS-485)

Serial output gas sensors can be interfaced directly to the MCX-32 controller without the need for I/O modules. This is accomplished by connecting the sensors in series to the controller’s Port 1 or Port 2 Modbus™ interface. Each serial sensor must have a unique Modbus™ address and be connected to the correct port for the controller to communicate properly. The assigned Modbus address for the serial sensor corresponds directly to the channel number in the controller.

Connect the five wires of a Modbus™ capable sensor (Detcon Model 600 and Model 700 Series, typically) to the DIN rail mounted terminal block labeled “RS-485 PORT1” or “RS-485 PORT2” and corresponding power terminal block labeled “VDC Out”. Each sensor connected to the Modbus™ must have a unique Modbus™ Address. The Modbus address assigned for serial sensor will define its channel number on the controller. (Modbus™ addresses are hexadecimal. Channels numbers are decimal. A conversion chart can be found in Section 10.1.) Sensors addressed between 01h and 20h correspond to channels 1-32 respectively and must be connected to Port 1. Sensors addressed between 21h and 40h correspond to channels 33-64 respectively and must be connected to Port 2.

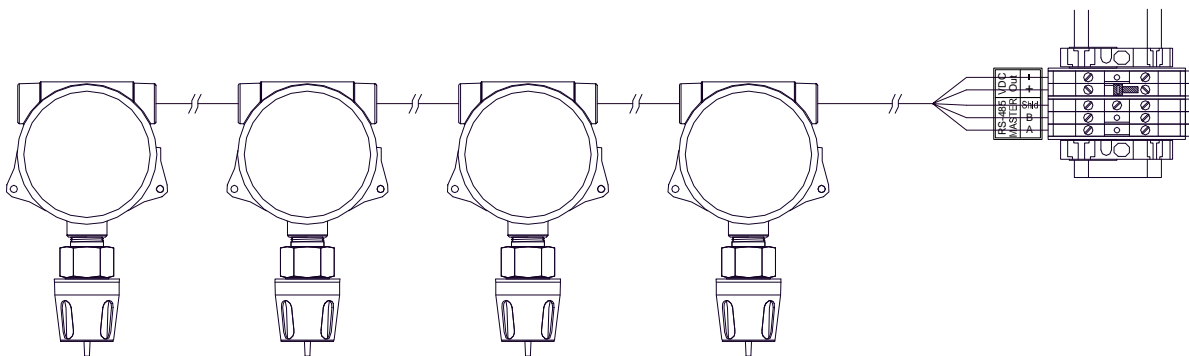

Figure 16 Modbus™ (Serial) Gas Sensor Connections

NOTE: Serial sensors addressed between 01h and 20h (channels 1-32) must be connected to Port 1. Serial sensors addressed between 21h and 40h (channels 33-64) must be connected to Port 2.

A System Auto Configuration can be performed for serial sensors and is accomplished by entering the ‘Menu’, and selecting ‘AUTO CONFIGURE SYSTEM’. More information on ‘AUTO CONFIGURE SYSTEM’ can be viewed in section 5.4.1.

After completing the auto configuration, the Channel Details screen for each sensor should be checked for accuracy. AUTO CONFIGURE SYSTEM does not complete the controller’s configuration. Some variables

are set to default, (such as Alarm set points), and may need to be adjusted for proper operation. The Channel Description is left blank and the Relay Bank Assignment for each sensor will default to all sixteen banks assigned.

3.7 Wireless RXT-320 Modbus™ Devices and CXT-320 Sensors

Detcon offers a wide range of wireless sensors and field devices for use with the MCX-32 wireless option if selected. Devices such as alarm stations, remote displays and various sensor types are available and able to communicate wirelessly using transceivers that operate at 2.4GHz and conform to non-licensed radio frequency appliance usage around the world. Refer to these devices specific manuals for more detailed information.

For proper communication, wireless devices must have a unique Modbus™ address and must reside on the same RF channel/Network ID as the wireless transceiver of the MCX-32 corresponding to the correct port for the controller. The assigned Modbus address for the serial sensor corresponds directly to the channel number in the controller. (Modbus™ addresses are hexadecimal. Channels numbers are decimal. A conversion chart can be found in Section 10.1.) Wireless sensors addressed between 01h and 20h correspond to channels 1-32 respectively and must be connected to Port 1 via the RF Channel/Network ID. Wireless sensors addressed between 21h and 40h correspond to channels 33-64 respectively and must be connected to Port 2 via the RF Channel/Network ID.

NOTE: Each wireless device in a network must have a unique Modbus address. All wireless devices in a network must reside on the same RF channel/Network ID. Each of the three communications port for the MCX-32 is considered an independent network and must each reside on a different RF channel/Network ID.

3.8 RXT-320 Wireless transceiver Analog Inputs

The RXT-320 wireless transceiver provides two 4-20mA inputs that can be used to monitor 4-20mA devices. The input values are continuously read and stored in two separate registers accessible through Modbus at the Modbus address assigned to the transceiver enabling analog inputs to be configured automatically with the Auto Configure function of the MCX-32.

The two 4-20mA inputs are accessible when an RXT-320 transceiver is connected to Detcon's optional Model 100 Terminal Board. 'AIN1' on connector J8 corresponds to analog input one and 'AIN2' on connector J7 corresponds to analog input two. During an Auto Configure, a 4-20mA signal must be active on these inputs in order for the controller to recognize them. If manually configured, refer to Table 6 Input Device Modbus™ Addresses for Port 1 and Table 7 Input Device Modbus™ Addresses for Port 2 for proper Modbus addressing and channel assignments reserved for RXT-320 analog inputs.

NOTE: If the RXT-320 is used for Analog inputs the Device Type in the configuration must be set properly for the MCX Controller to recognize the RXT as an analog input device.

NOTE: If only one analog input is to be used, it is recommended to interface the mA output of the sensor to AIN1.

The 4-20mA signals from the RXT-320 transceivers are communicated wirelessly to the controller using RS-485 Modbus™ RTU protocol therefore each wireless transceiver must have a unique Modbus™ address. Wireless transceivers are serially addressed in hex using the two rotary switches on the transceiver's smart terminal board (Figure 17). SW2 corresponds to the most significant digit (MSD) and SW1 corresponds to the least significant digit (LSD). Each analog input has a specific channel assigned in the controller and is dependent on the Modbus address set from the smart term board. All other information will need to be

modified on the Channel Details screen for each channel corresponding to the appropriate RXT320 analog input.

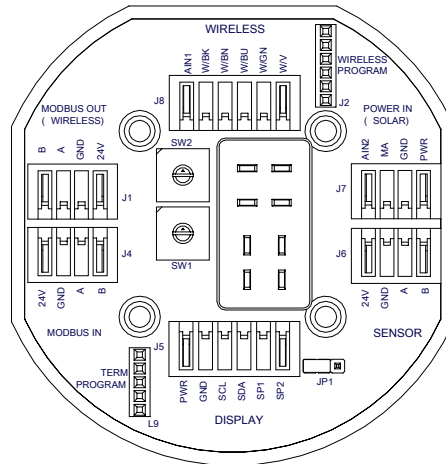

Figure 17 Model 100 Terminal Board

NOTE: RXT-320 analog inputs can be interfaced to either Port 1 or Port 2, they must be addressed correctly and only those channels associated with the analog inputs will be available. During an Auto Configure, only RXT-320 analog inputs with an active 4-20mA signal will be recognized.

Table 4 Wireless Transceiver Analog Input Modbus™ Addresses

Port	WT	Analog Inputs	Channel #	Modbus Address (Decimal)	Modbus Address (Hex)	WT	Analog Inputs	Channel #	Modbus Address (Decimal)	Modbus Address (Hex)
1	1	Input 1	1	1	1	9	Input 1	17	9	9
		Input 2	2				Input 2	18		
	2	Input 1	3	2	2	10	Input 1	19	10	A
		Input 2	4				Input 2	20		
	3	Input 1	5	3	3	11	Input 1	21	11	B
		Input 2	6				Input 2	22		
	4	Input 1	7	4	4	12	Input 1	23	12	C
		Input 2	8				Input 2	24		
5	Input 1	9	5	5	13	Input 1	25	13	D	
	Input 2	10				Input 2	26			
6	Input 1	11	6	6	14	Input 1	27	14	E	
	Input 2	12				Input 2	28			
7	Input 1	13	7	7	15	Input 1	29	15	F	
	Input 2	14				Input 2	30			
8	Input 1	15	8	8	16	Input 1	31	16	10	
	Input 2	16				Input 2	32			
2	17	Input 1	33	33	21	25	Input 1	49	41	29
		Input 2	34				Input 2	50		
	18	Input 1	35	34	22	26	Input 1	51	42	2A
		Input 2	36				Input 2	52		
	19	Input 1	37	35	23	27	Input 1	53	43	2B
		Input 2	38				Input 2	54		

Port	WT	Analog Inputs	Channel #	Modbus Address (Decimal)	Modbus Address (Hex)	WT	Analog Inputs	Channel #	Modbus Address (Decimal)	Modbus Address (Hex)
	20	Input 1	39	36	24	28	Input 1	55	44	2C
		Input 2	40				Input 2	56		
	21	Input 1	41	37	25	29	Input 1	57	45	2D
		Input 2	42				Input 2	58		
	22	Input 1	43	38	26	30	Input 1	59	46	2E
Input 2		44	Input 2				60			
23	Input 1	45	39	27	31	Input 1	61	47	2F	
	Input 2	46				Input 2	62			
24	Input 1	47	40	28	32	Input 1	63	48	30	
	Input 2	48				Input 2	64			

For manual configuration, set the desired Modbus address on the smart terminal board, enable the corresponding channels to be used and modify the information on the Channels Details screen to reflect the correct sensor type and information. Setting up an RXT-320 analog input should start by selecting the ‘Device Type’ from the Channel Details screen, and selecting ‘RXT Analog’ from the ‘DEVICE SELECTION’ screen. If the controller does not detect an RXT-320 analog input, the controller will display “COMM ERR” in the ‘Status’ field. A properly addressed RXT-320 transceiver that is correctly interfaced to the controller will respond to channel activation with a concentration reading. When the controller has detected the RXT-320 analog input, the gas type will default to H2S, the range will default to 100, and the analog out will default to ‘OFF’. Once the RXT-320 analog input has been properly detected, all of the information needed to identify the sensor can be entered in the Channel Details screen to set the correct parameters for the sensor.

3.9 SmartWireless® CXT Sentinel Slave Controller

Detcon offers a SmartWireless® CXT Sentinel Slave Controller which can be configured to the MCX-32 controller if the wireless option is selected. The CXT Sentinel Slave Controller is a wireless RXT320 device that transmits data from up to four wired analog sensors back to the MCX-32 wirelessly using radios that operate at 2.4GHz and conform to non-licensed radio frequency appliance usage around the world. Refer to the SmartWireless® CXT Site Sentinel manual for more detailed information. The CXT Sentinel Slave Controller’s wireless transceiver must reside on the same RF channel/Network ID as the wireless transceiver of the MCX-32 corresponding to the correct port for the controller. RF channel/Network ID selection is accomplished using the SW1 rotary switch. The CXT Sentinel Slave Controller address must be unique, and should be set between 01h and 20h when configured to Port 1 and between 21h and 40h when configured to Port 2.

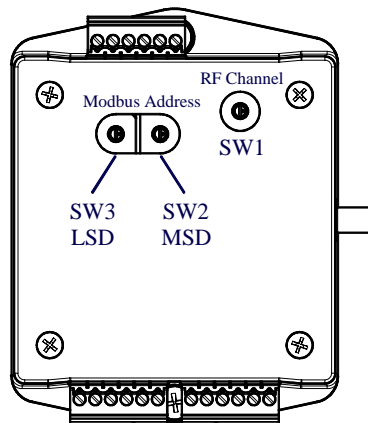

Figure 18 CX/CXT Wireless Transceiver

The CXT Sentinel Slave Controller has the option of employing a Relay Output PCA. The relay output PCA of the CXT Sentinel Slave Controller is controlled by the CXT Sentinel Slave Controller, and is not, and should not be considered as part of the MCX Alarms. The MCX has no control over the CXT Sentinel Slave Controller's relay output PCA. This Relay Output PCA can only be set according to the Slave Controller, and can only be used to control alarms that are set up by and attached to the Slave Controller.

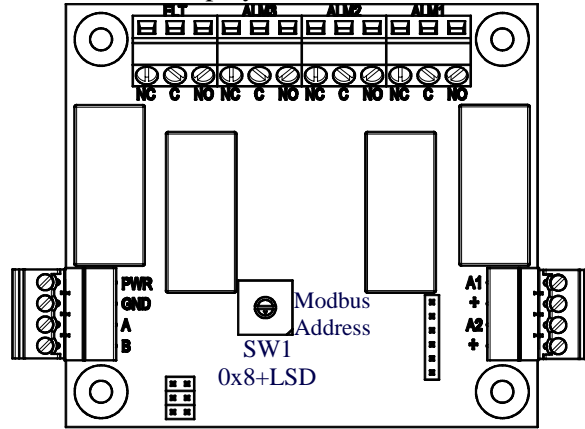

Figure 19 CX/CXT Relay Output PCA

The analog input card of the CXT Sentinel Slave Controller functions similar to a DA4 module. It is found mounted under the relay output PCA.

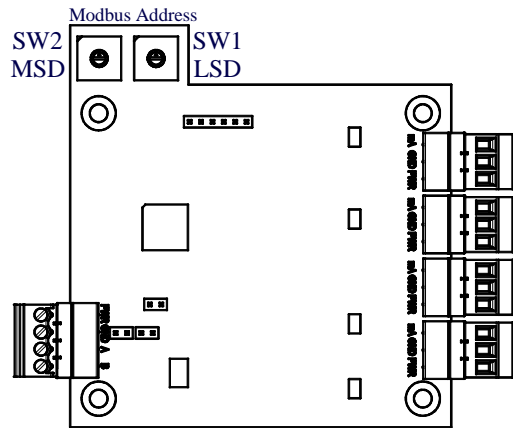

Figure 20 CX/CXT Analog Input PCA

The 4-20mA signals from the sensors are communicated by the CXT Sentinel Slave Controller to the MCX controller using RS-485 Modbus™ RTU protocol. The analog input PCA is serially addressed to the CXT Sentinel Slave Controller in hex using the two rotary switches labeled SW2 MSD (most significant digit) and SW1 LSD (least significant digit). The analog input PCA should have an address of 01h to interface properly with the CXT Sentinel Slave Controller. The CXT Sentinel Slave Controller then communicates with the MCX Controller, and the CXT Sentinel Slave Controller then acts as the controlling device to the analog input PCA.

NOTE: CXT Sentinel Slave Controllers can be connected to either Port 1 or Port 2, they must be addressed correctly and only those channels associated with that CXT Sentinel Slave Controller will be available. During an Auto Configure, only CXT Sentinel Slave Controller inputs with an active 4-20mA signal will be recognized.

3.10 SmartWireless® CX Sentinel Sensor Station

Detcon offers a SmartWireless® CX Sensor Station which can be configured to the MCX-32 controller if the wireless option is selected. The CX Sensor Station is a wireless RXT320 device that transmits data from up to four wired analog sensors back to the MCX-32 wirelessly using radios that operate at 2.4GHz and conform to non-licensed radio frequency appliance usage around the world. Refer to the CX Sensor Station manual for more detailed information. The CX Sensor Station's wireless transceiver must reside on the same RF channel/Network ID as the wireless transceiver of the MCX-32 corresponding to the correct port for the controller. RF channel/Network ID selection is accomplished using the SW1 rotary switch. The CX Sensor Station also consists of three different Modbus components that must be addressed accordingly for proper communication. These three Modbus components are located in the CX wireless transceiver, the CX relay output PCA and the CX analog input PCA, each requiring unique Modbus addressing as follows:

The wireless transceiver of the CX Sensor Station can be addressed between 01h and 20h when configured to Port 1 and can be addressed between 21h and 40h when configured to Port 2. Wireless transceivers are serially addressed in hex using the two rotary switches on the transceiver (Figure 18). The SW2 rotary switch corresponds to the most significant digit (MSD) and the SW3 rotary switch corresponds to the least significant digit (LSD).

The relay output PCA of the CX Sensor Station functions similar to an RL4 module and needs to be addressed and configured as such. The most significant digit (MSD) for the relay output PCA is hard coded to a hex value of 8 so only the least significant digit (LSD) must be set using the SW1 rotary switch (Figure 19). Reference section 3.4 Alarm Relay Outputs (RL-4) for proper addressing and configuration.

NOTE: The MSD for the relay output PCA is hard coded to a hex value of 8 so only the LSD must be set. Addressing criteria is the same as RL4's and Alarm Stations and will be seen as an RL4 by the MCX. Reference Table 3.

The analog input card of the CX Sensor Station functions similar to a DA4 module. It is found mounted under the relay output PCA.

The 4-20mA signals from the sensors are communicated by the CX Sensor Station to the controller using RS-485 Modbus™ RTU protocol. The analog input PCA is serially addressed in hex using the two rotary switches labeled SW2 MSD (most significant digit) and SW1 LSD (least significant digit) (Figure 20). Each CX Site Sentinel will have four channels reserved based on its Modbus address with each channel corresponding to each of its four inputs. The CX analog input PCA must be addressed according to Table 5.

NOTE: CX Sensor Stations can be connected to either Port 1 or Port 2, they must be addressed correctly and only those channels associated with that CX Sensor Station will be available. During Auto Configure, only CX Sensor Station inputs with an active 4-20mA signal will be recognized.

Table 5 Wireless CX Sensor Station Analog Input Card Modbus™ Addresses

Port	CX Sensor Station	CX Analog Inputs	Channel #	Modbus Address (Hex)	CX Sensor Station	CX Analog Inputs	Channel #	Modbus Address (Hex)
1	1	Input 1	1	40	5	Input 1	17	44
		Input 2	2			Input 2	18	
		Input 3	3			Input 3	19	
		Input 4	4			Input 4	20	
2	2	Input 1	5	41	6	Input 1	21	45
		Input 2	6			Input 2	22	
		Input 3	7			Input 3	23	
		Input 4	8			Input 4	24	
3	3	Input 1	9	42	7	Input 1	25	46
		Input 2	10			Input 2	26	
		Input 3	11			Input 3	27	
		Input 4	12			Input 4	28	
4	4	Input 1	13	43	8	Input 1	29	47
		Input 2	14			Input 2	30	
		Input 3	15			Input 3	31	
		Input 4	16			Input 4	32	
2	9	Input 1	33	48	13	Input 1	49	4C
		Input 2	34			Input 2	50	
		Input 3	35			Input 3	51	
		Input 4	36			Input 4	52	
10	10	Input 1	37	49	14	Input 1	53	4D
		Input 2	38			Input 2	54	
		Input 3	39			Input 3	55	
		Input 4	40			Input 4	56	
11	11	Input 1	41	4A	15	Input 1	57	4E
		Input 2	42			Input 2	58	
		Input 3	43			Input 3	59	
		Input 4	44			Input 4	60	
12	12	Input 1	45	4B	16	Input 1	61	4F
		Input 2	46			Input 2	62	
		Input 3	47			Input 3	63	
		Input 4	48			Input 4	64	

For manual configuration, set the RF channel/Network ID on the CX wireless transceiver to the same value as the wireless transceiver of the MCX-32 controller for the correct port. Next, set the desired Modbus address for all three Modbus components of the CX Sensor Station and enable the corresponding channels to be used, the corresponding Wireless Transceiver and the corresponding “RL4”. Select the “CX Sentinel” device type from the Channel Details screen for each channel used. If the controller does not detect a CX Sensor Station, the controller will display “COMM ERR” in the ‘Status’ field. A properly addressed CX Sensor Station will respond to channel activation with a concentration reading for the analog sensors configured. When the controller has detected the CX Sensor Station, the gas type will default to H2S, the range will default to 100, and the analog out will default to ‘OFF’. Once the CX Sensor Station has been properly detected, all of the information needed to identify the sensor can be entered in the Channel Details screen to set the correct parameters for the sensor.

3.11 Remote Monitoring and Control

The MCX-32 has the ability for remote monitoring and control through a built in web server. This web server interfaces to TCP/IP local networks with a DHCP server through an Ethernet connection. When an MCX-32 is connected to a Local Area Network (LAN) with a DHCP server, it will automatically be assigned an IP address which can be viewed from the “About System” menu in the Main Menu. The assignment and determination of the IP address will be dependent on the configuration and equipment of the DHCP server. It is recommended to consult with an IT representative to ensure there is no disruption of service on the network. Once the IP address is assigned, the remote interface can then be accessed via any web browser by typing in the IP address. A security window will then appear and prompt the user to enter a User name and Password. Enter ‘detcon’ in lower case letters for both the User name and Password. Once verified and accepted, the ‘G3 Web Server’ page will be displayed. Selecting ‘Remote View’ will display an interactive view of the MCX-32 controller screen (Figure 21) which can be used to view and control it remotely. Refer to Section 11.1 for more information on the remote feature.

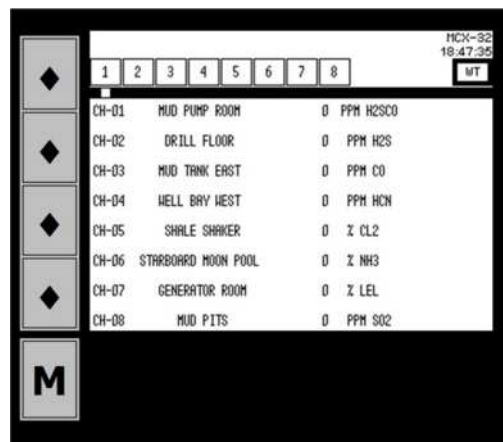

Figure 21 MCX-32 Remote Interface

3.12 Auxiliary Relays

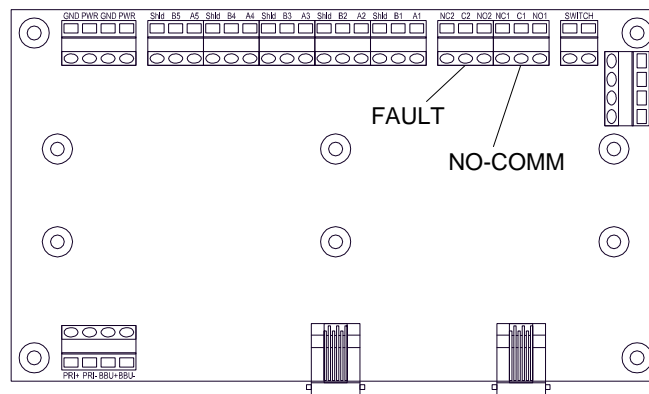

Figure 22 Interface PCA

The Interface PCA (Figure 22) contains terminals for connection to the Auxiliary Relays (Fault and No-Comm). Wiring to these relays should be brought directly to the Interface PCA. The terminal blocks on the Interface PCA are labeled NO1, C1, and NC1 for the NO-COMM relay, and NO2, C2, and NC2 for the FAULT relay. (NO – Normally Open Contact, C – Common Contact, and NC – Normally Closed Contact.)

These relays may be setup as Energized or De-energized, Silence or Non Silence, and Latched or Unlatched, refer to section 5.4.8

3.13 General Wiring and Configuration Notes

- ❖ Follow generally accepted guidelines for RS-485 serial networks. Do not wire I/O Modules and/or Modbus™ gas sensors in long-distance ‘T-Tap’ configurations. Instead, use a “daisy-chain” wiring scheme.
- ❖ Use Detcon Recommended cabling whenever possible.
 - General Cable Commodore p/n ZO16P0022189 is recommended for a single cable providing serial communications and power.
- ❖ Ground the cable shielding at the Model MCX-32 controller *only*. Other points of grounding may cause a ground loop, and induce unwanted noise on the RS-485 line, which in turn may disrupt communications.
- ❖ For wireless installations, verify that all devices in the wireless network reside on the same RF channel as transceivers will only respond to other transceivers with the same RF channel.
- ❖ If multiple wireless networks are implemented, each wireless network must exist on a separate RF channel in order to avoid cross talk and interference between networks.
- ❖ Any slave device near an elevated antenna needs to be at least as far from the antenna as the antenna is high. For example, if the antenna is 20ft. high, then the nearest slave device should be at least 20 ft. away.

3.14 Initial Start-Up

The MCX-32 controller will power up as soon as power is applied. There is no external power switch to the unit.

NOTE: Before applying power, check to make sure that all the wiring connections and external devices are installed correctly.



CAUTION

Applying power with devices hooked up incorrectly may cause damage to the equipment.

When power is applied to the unit, the unit will boot up and run various initialization steps. It will proceed to poll Modbus™ addresses of any configured devices and will display their associated channels. This is considered normal operation.

If a previous configuration does not exist, the user will need to run the auto configuration function or manually configure the network from the user-interface. After the unit has been configured, the unit will begin normal operation. If the unit has been configured properly, the unit will display the current status of the devices that it is interfaced to.

Apply test gas to each sensor connected to the MCX-32. Verify that the correct alarm outputs are activated when gas is applied. If AO-4 modules are installed, the current output for each channel should also be verified.

4.0 CompactFlash Card

The MCX-32 controller has a feature that allows data logging when a CompactFlash (CF) memory card is installed. The CF card must be installed in the CF slot located on the back of the controller's display unit before the controller is powered up (Figure 23). The controller will automatically format the card and create the necessary files for data logging. Data is recorded onto these files which can then be viewed from the controller's Compact Flash screen at the user's convenience. The CF card can also save the controller's current configuration and be used to load its saved configuration to other MCX-32 controllers. See Section 5.4.12 for more information regarding the data logging feature and Compact Flash screen.

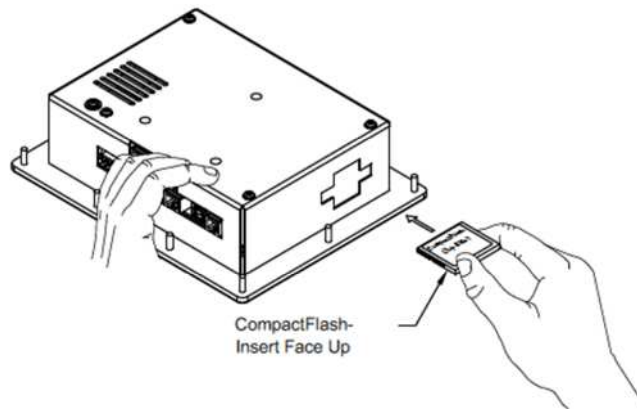

Figure 23 CompactFlash Card Installation

NOTE Data logging does not occur during the first 10 minutes after power-up of the unit. This delay allows the sensors time to stabilize, so that inaccurate or faulty readings will not be logged during this stabilization period.

NOTE: Do not remove or insert the CompactFlash card while power is applied.

5.0 Operation

5.1 Main Display Screen

The Main Display screen of the MCX-32 controller consists of two main sections. There is a primary sensor/device section and if wireless devices are configured, there is a secondary wireless transceiver section.

The primary sensor section displays up to eight channels of information at a time per tab. One or more tabs may be displayed near the top of the channel display area. Each of these tabs displays information for up to eight channels. Touching any of these tabs will cause the screen to display the channels associated with that tab. In normal operation, the screen will loop through each tab displaying all of the channels that are programmed into the controller. The channel number corresponds directly to a serial sensor's Modbus address.

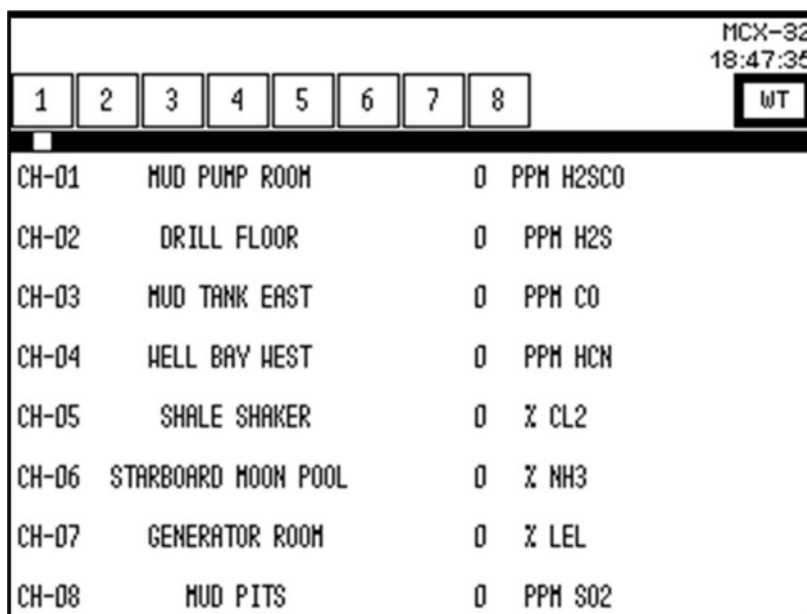

Figure 24 Model MCX-32 Main Display Screen (Sensor Section)

If any wireless devices are configured, a tab labeled 'WT' for Wireless Transceivers will be available. Selecting this tab will display the wireless transceivers that have been configured to the MCX-32. The wireless transceiver section displays up to eight rows of transceiver information at a time per tab. One or more tabs may be displayed near the top of the transceiver display area. Each of these tabs displays information for up to eight transceivers. Touching any of these tabs will cause the screen to display the transceivers associated with that tab. In normal operation, the screen will loop through each tab of the primary sensor section followed by each tab of the wireless transceiver section. While in the wireless transceiver section, a tab labeled 'SNS' for Sensors will be available which allows the user to return to the primary sensor section when selected.

MCX-32					
19:21:08					
1					
SNS					
0x01	Wireless TRX-01	O.K.	12.03 VDC	8 DAYS	100%
0x09	Wireless TRX-09	O.K.	23.40 VDC	NON-RCHR	100%
0x0A	Wireless TRX-10	O.K.	23.46 VDC	NON-RCHR	100%
0x0B	Wireless TRX-11	O.K.	23.57 VDC	NON-RCHR	100%
0x0C	Wireless TRX-12	O.K.	23.52 VDC	NON-RCHR	100%
0x0D	Wireless TRX-13	O.K.	23.49 VDC	NON-RCHR	100%
0x80	Alarm Station 01	O.K.	12.14 VDC	89%	100%
0x82	Alarm Station 03	O.K.	DC POWER		100%

Figure 25 Model MCX-32 Main Display Screen (Wireless Transceiver Section)

Each tab display will remain on screen for approximately ten seconds (default) and will then move to the next tab if available. If any events such as alarms, status, faults are active, the screen will remain on the tab with the active event. If multiple events occur in different tabs, the screen will alternate every five seconds between the tabs with active events. The “screen switching” interval time is adjustable by the user and can also be turned off if needed. Channel and transceiver information are displayed in rows. In the sensor section, each row provides the channel number, the channel description, the current sensor reading, the gas type, and any active alarms, status or faults. In the transceiver section, each row provides the transceiver Modbus address (in hex), the transceiver description, the status, the voltage, the battery life (for smart batteries) and the RF link quality. In the sensor section, selecting a channel on the screen will open the Channel Details screen for that channel, and display all of that channel’s information. In the wireless transceiver section, selecting a wireless transceiver on the screen will open the Wireless Transceiver Details screen for that transceiver and display all of its information.

Along the side of the display are a group of navigation and action buttons labeled: ‘HOME’, ‘ALARM RESET’, ‘ALARM SILENCE’, ‘ALARM INHIBIT’, and ‘MENU’. These buttons perform different tasks when pressed:

- HOME – Return to the Main screen. This button will return the display to the Main screen from any other screen.
- ALARM RESET – When latched alarms have occurred, this button will reset all latched alarm notifications.
- ALARM SILENCE – When a silenceable alarm is active, this button will silence or acknowledge all alarm notifications.
- ALARM INHIBIT – This button will display the Alarm Inhibit screen (Password protected). See Section 5.4.3 Alarm Inhibit Screen.
- MENU – This button will display the System Configuration screen (Password protected). See Section 5.4.

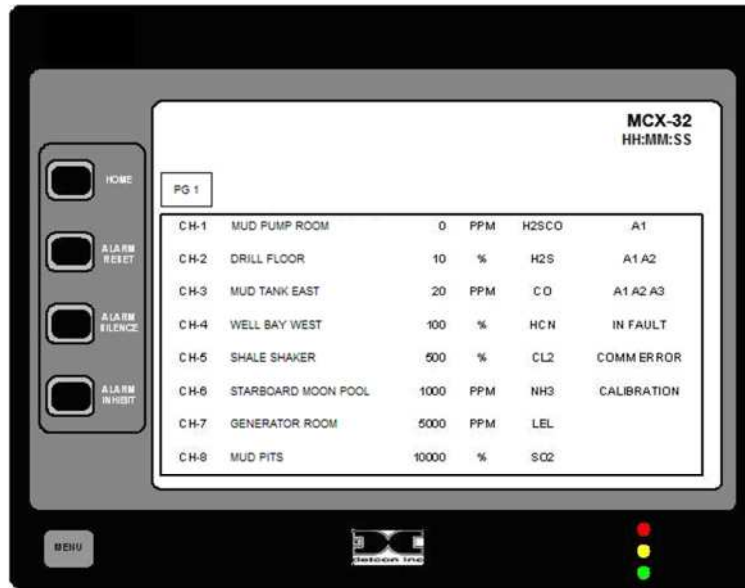

Figure 26 Model MCX-32 Main Display

NOTE: Alarm Reset and Alarm Silence are configurable and operation is determined by the settings in the RL4/ALM STATION SETUP menu. See Section 5.4.8.

5.1.1 Password Protection

The MCX-32 controller incorporates password protection to keep un-authorized personnel from inadvertently changing the controller’s configuration. If not already logged in, pressing the ‘MENU’ button will take the user to the USER LOGIN screen and be prompted to enter a valid password. Selecting the asterisks field will display an on screen numeric keypad that the user should use to enter the password. The default password is ‘1234’ and once logged in, can be changed in the CHANGE PASSWORD menu from the MAIN MENU screen. Any numeric value up to ten digits is considered a valid password. The user will remain logged in for 1 minute after the last executed action at which time, the unit will automatically log off, thus requiring the user to log in again for any further changes. The user can also log off manually by selecting the ‘LOG OFF’ button when available.

5.2 Channel Details Screen

Detailed information for any sensor can be found on the Channel Details screen. This screen can be viewed by selecting a channel from the sensor section of Main Display screen. After selecting the appropriate channel, the Channel Details screen will be displayed.

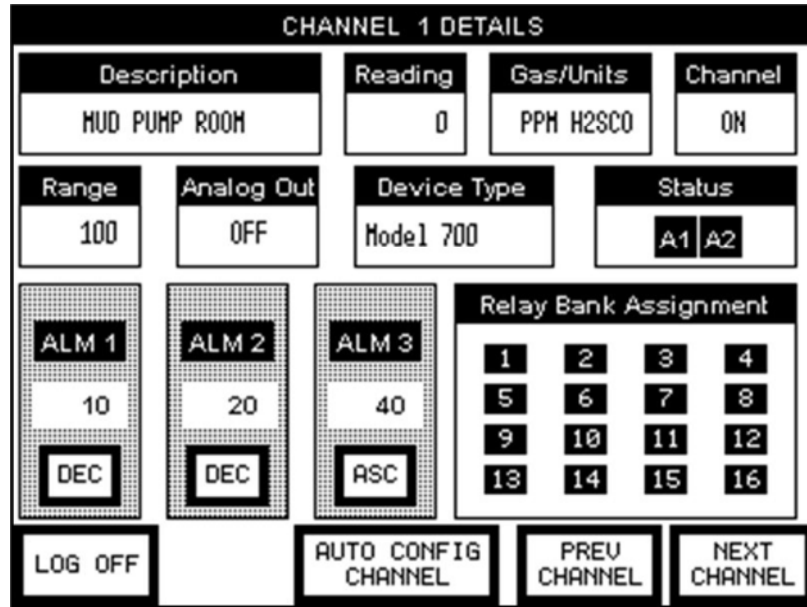

Figure 27 Channel Details Screen

The Channel Details screen is used to view or change information directly related to a sensor. The Channel Details screen displays the sensor’s description, the current reading, the gas type & units, the channel’s on/off status, the range of the sensor, the analog output status, the device type, the sensor status, the alarm values and the bank(s) the alarms are associated with. Refer to Section 6.0 Controller Setup for the proper setup and configuration of sensors connected to the controller.

In order to make changes to certain values on the Channel Details screen, the user must be logged in to the MCX-32. To log in, select the ‘LOG ON’ button at the bottom of the screen which will display the USER LOGON screen. Select the asterisks field and enter a valid password. Once logged in, changes to certain fields can be made by simply touching the field requiring the change.

NOTE: The user must be logged in to the MCX-32 in order to make changes to fields in the Channel Details screen.

5.3 Wireless Transceiver Details Screen

Detailed information for any wireless transceiver can be found on the Wireless Transceiver Details screen. This screen can be viewed by selecting a transceiver from the wireless transceiver section of Main Display screen. After selecting the appropriate transceiver, the Wireless Transceiver Details screen will be displayed.

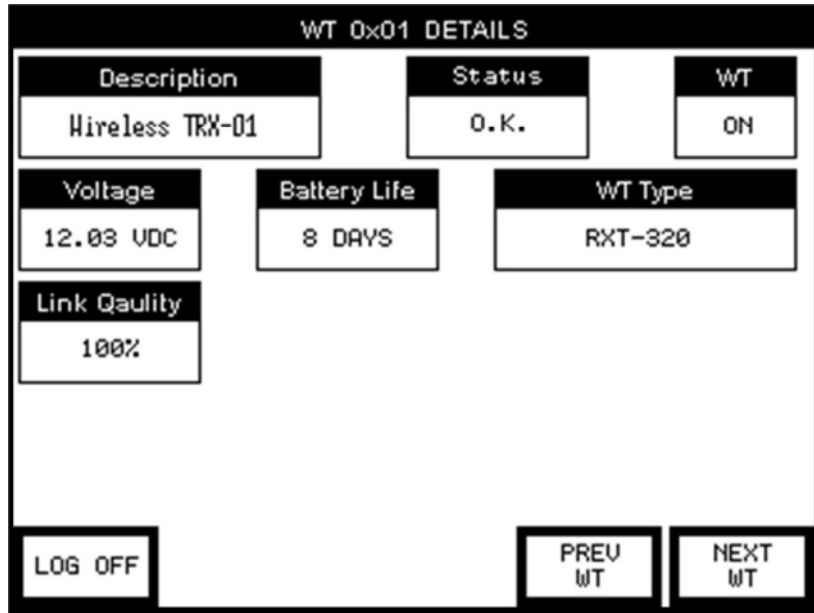

Figure 28 Wireless Transceiver Details Screen

The Wireless Transceiver Details screen is used to view or change information directly related to a transceiver. The Wireless Transceiver Details screen displays the transceiver’s description, the current status, the transceivers on/off status, the voltage, the battery life, the wireless transceiver device type and the RF link quality. Refer to Section 6.0 Controller Setup for the proper setup and configuration of wireless transceivers interfaced to the controller.

In order to make changes to certain values on the Wireless Transceiver Details screen, the user must be logged in to the MCX-32. To log in, select the ‘LOG ON’ button at the bottom of the screen which will display the USER LOGON screen. Select the asterisks field and enter a valid password. Once logged in, changes to certain fields can be made by simply touching the field requiring the change.

NOTE: The user must be logged in to the MCX-32 in order to make changes to fields in the Wireless Transceiver Details screen.

5.4 Main Menu Screen

Pressing the ‘MENU’ button will display the Main Menu screen when logged in.

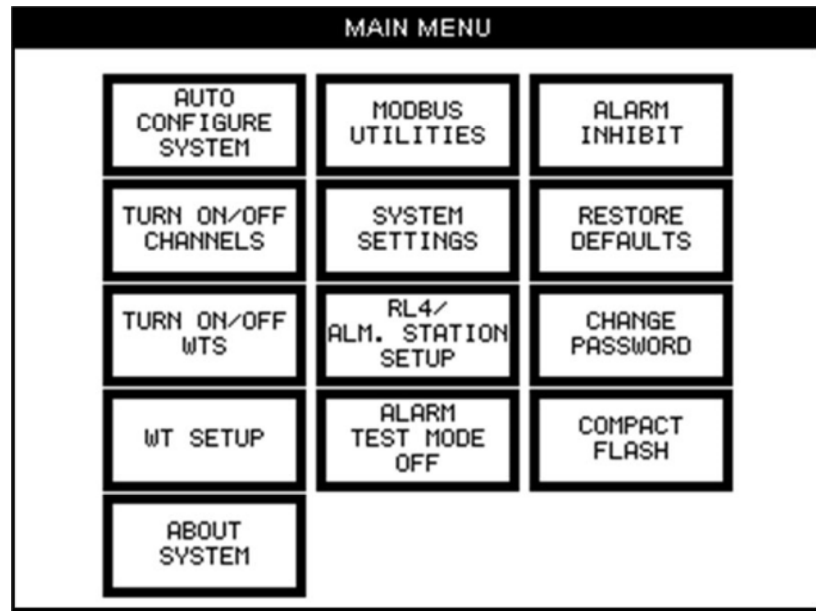

Figure 29 Main Menu Screen

NOTE: The COMPACT FLASH menu button only appears if a CompactFlash card has been successfully installed in the MCX-32 controller.

The Main Menu screen provides access to thirteen different menus that allow the user to change the controller's configuration.

- 1) AUTO CONFIGURE SYSTEM
- 2) MODBUS UTILITIES
- 3) ALARM INHIBIT
- 4) TURN ON/OFF CHANNELS
- 5) SYSTEM SETTINGS
- 6) RESTORE DEFAULTS
- 7) TURN ON/OFF WTS
- 8) RL4/ALM STATION SETUP
- 9) CHANGE PASSWORD
- 10) WT SETUP
- 11) ALARM TEST MODE
- 12) COMPACT FLASH
- 13) ABOUT SYSTEM

NOTE: Changing the controller's configuration should only be performed by authorized personnel. Improper settings in the controller's configuration can cause the controller to operate incorrectly.

5.4.1 Auto Configure System Screen

Auto Configure System will automatically search for 100, 600D, 600C, 700, CXT320, RXT320 sensors/devices and I/O modules and populate their channel data fields with information obtained from their Modbus™ interface. This function is primarily intended for new system installations or a complete system re-configuration. Completion of this function after a controller has been configured will overwrite all previous configuration parameters.

Upon entering the Auto Configure System menu, selecting the 'Start' button allows the controller to automatically start a search for serial sensors/devices on both ports simultaneously and poll the Modbus™ with a request for information on any sensor/device found. If a response is received, the controller will poll the sensor for information on the device type. If the device is a Detcon series sensor, the controller will obtain configuration information from that sensor and store the information. (This information can be viewed on the channel's corresponding Channel Details screen.) If no sensor/device is located at that address, the controller will populate the Channel Details screen to reflect that no sensor/device was found and mark that channel as 'OFF'. The controller will then increment to the next address and repeat the process. The controller will continue until it has polled all 64 possible addresses and display the total number of channels found. The controller will continue to search for RL-4/I/O Modules and Alarm Stations starting at addresses 80h and continuing through 8Fh for both ports and will indicate the total number of RL-4/Alarm Stations found. The controller will then search for AO-4 modules at addresses A0h through AFh and will indicate the total number of AO-4 modules found. Finally, the controller will search for wireless transceivers for both ports at their respective addresses and will indicate the total number of transceivers found. Sensors or other serial devices not identified by this process can be configured manually.

The first section of the Auto Configure System function consists of the controller's search for all 64 serial sensor addresses. The second section is the search for all 32 RL-4/Alarm Station addresses. The third section is the search for all 16 AO-4 module addresses. The fourth section is the search for all wireless transceiver addresses. The user can skip the search of any of these sections by selecting the 'SKIP' button located at the bottom of the screen at any time during the search. The user can also cancel the Auto Configure System function by selecting the 'CANCEL' button located at the bottom of the screen at any time during the search. By selecting the 'CANCEL' button, the controller will revert to the previous configuration before the Auto Configure System function was initiated. If the user selects the 'DONE' button located at the bottom of the screen, the controller will save the current configuration of all devices found up to that point, overwriting any previous configuration.



Figure 30 Auto Configure System Screen

5.4.2 Modbus Utilities Screen

The Modbus Utilities screen contains six menus which provide the ability to check the status of all Modbus™ addresses for the MCX-32 controller to include all 64 channel addresses, all 32 RL-4/Alarm Station addresses and all 16 AO-4 addresses. This screen also allows various Modbus timeout values to be modified and to

change the values for interval updates of RL4s, AO4s and wireless transceivers. Error counters can be reset as well from this screen.

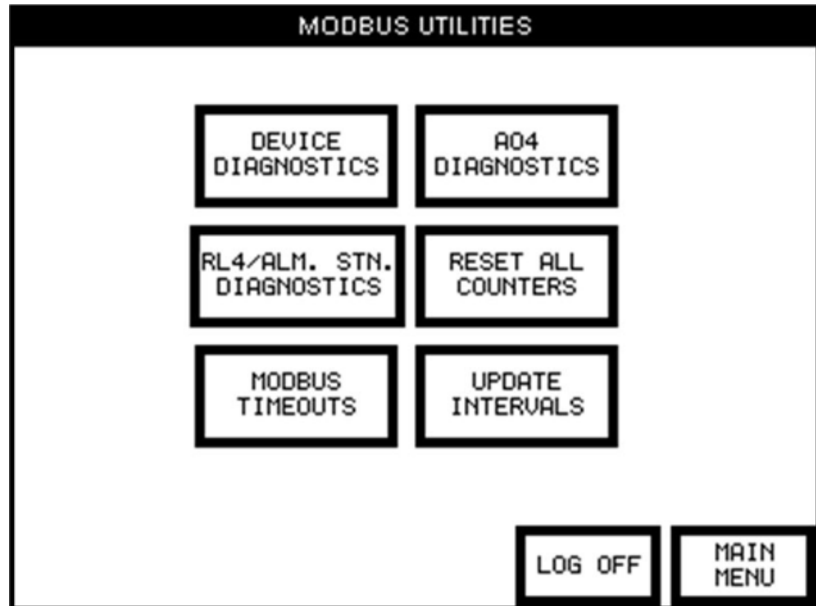

Figure 31 Modbus Utilities

5.4.2.1 Device Diagnostics Screen

The Device Diagnostics menu button will display information associated with the controller’s 64 channel addresses, displaying 8 addresses per page and the Modbus™ address will be shown as a decimal value. The information displayed consists of the Modbus Address, Status, COMM Error Count and COMM Error Total Time.

DEVICE MODBUS DIAGNOSTICS			
MODBUS ADDRESS	STATUS	COMM ERROR COUNT	COMM ERROR TOTAL TIME
01	OK	0	00:00:00
02	OK	0	00:00:00
03	OK	0	00:00:00
04	OK	0	00:00:00
05	OK	0	00:00:00
06	OK	0	00:00:00
07	OK	0	00:00:00
08	OK	0	00:00:00

Figure 32 Device Modbus Diagnostics Screen

5.4.2.2 RL4/Alarm Station Diagnostics Screen

The RL4/Alm Stn Diagnostics menu button will display information associated with the controller’s 32 alarm device addresses, displaying 2 addresses per bank and the Modbus™ address will be shown as a hexadecimal value. The information displayed consists of the Modbus Address, Status, COMM Error Count and COMM Error Total Time.

RL4/ALARM STATION MODBUS DIAGNOSTICS			
MODBUS ADDRESS	STATUS	COMM ERROR COUNT	COMM ERROR TOTAL TIME
0x80	OFF	0	00:00:00
0x81	OFF	0	00:00:00
BANK 1			
LOG OFF		PREV BANK	NEXT BANK
			MODBUS UTIL.

Figure 33 RL4/Alm Stn Diagnostics Screen

5.4.2.3 AO4 Diagnostics Screen

The AO4 Diagnostics menu button will display information associated with the controller’s 16 AO-4 addresses, displaying 8 addresses per page and the Modbus™ address will be shown as a hexadecimal value. The information displayed consists of the Modbus Address, Status, COMM Error Count and COMM Error Total Time.

AO4 MODBUS DIAGNOSTICS			
MODBUS ADDRESS	STATUS	COMM ERROR COUNT	COMM ERROR TOTAL TIME
0xA0	OFF	0	00:00:00
0xA1	OFF	0	00:00:00
0xA2	OFF	0	00:00:00
0xA3	OFF	0	00:00:00
0xA4	OFF	0	00:00:00
0xA5	OFF	0	00:00:00
0xA6	OFF	0	00:00:00
0xA7	OFF	0	00:00:00
LOG OFF		NEXT PAGE	MODBUS UTIL.

Figure 34 RL4/Alm Stn Diagnostics Screen

5.4.2.4 Modbus Timeouts Screen

The Modbus Timeouts menu button displays four values pertaining to Modbus communications that can be modified if needed. Inter Poll Delay is the amount of time in milliseconds the MCX-32 will wait after receiving a poll response from one sensor/device before it polls the next sensor/device. Response Timeout is the amount of time in milliseconds the MCX-32 will wait for a sensor/device to respond to a poll request. Retries Before Comm Error is the number of times the MCX-32 will poll a sensor/device before it declares it in communication error. Comm Error Recovery Hold Off is the number of full poll cycles the MCX-32 will complete before retrying to establish communication with the sensor/device in communication error. To change these values, select the appropriate field and use the displayed numeric keypad accordingly. Select 'ENTER' to save the value.

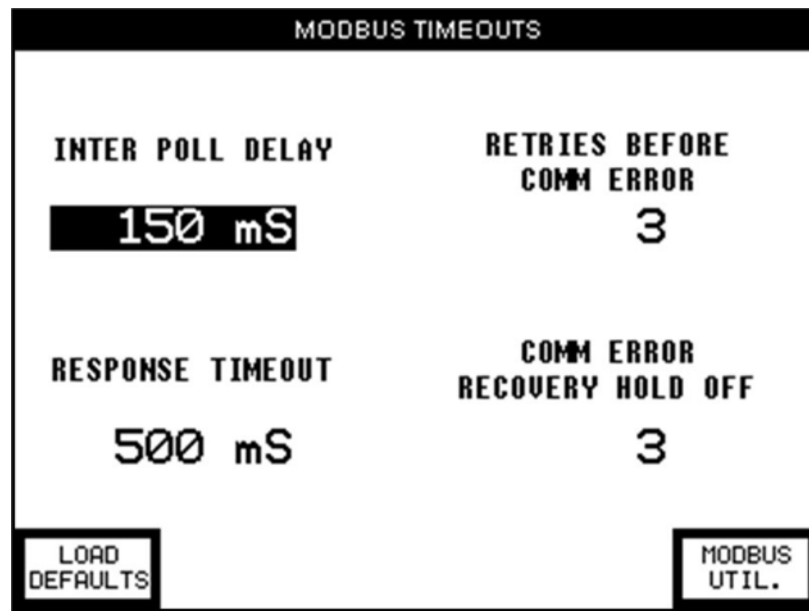

Figure 35 Modbus Timeout Screen

NOTE: The controller’s Modbus timeout values should not be altered unless instructed to do so by Detcon Factory personnel. Improper settings in these values can cause the controller to operate incorrectly.

5.4.2.5 Update Intervals Screen

The Update Intervals menu button displays interval update values in seconds for RL4s, AO4s and Wireless Transceivers. This interval is the amount of time the MCX will wait before it polls these devices to update their status. To change these values, select the appropriate field and use the displayed numeric keypad accordingly. Select 'ENTER' to save the value.

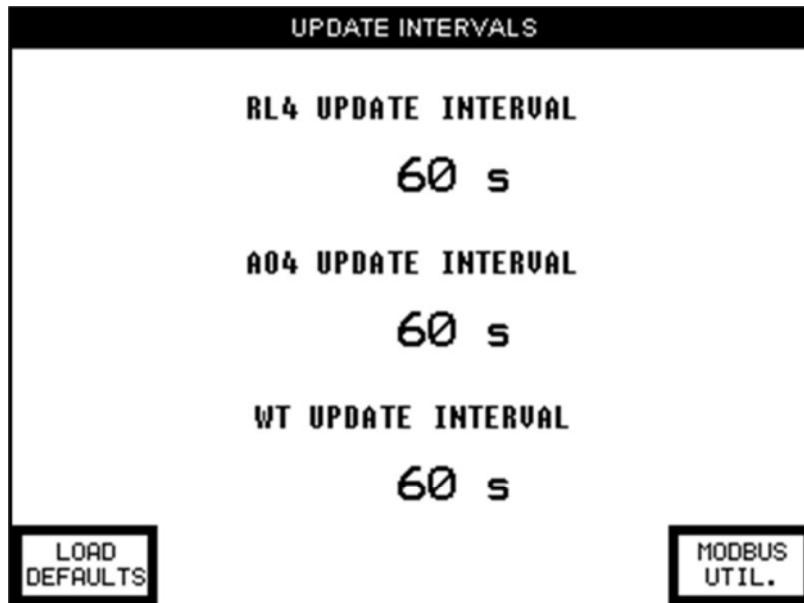

Figure 36 Update Intervals Screen

5.4.2.6 Reset All Counters Menu

Selecting the RESET ALL COUNTERS menu button and selecting YES will reset all the COMM Error Count and the COMM Error Total Time values to zero.

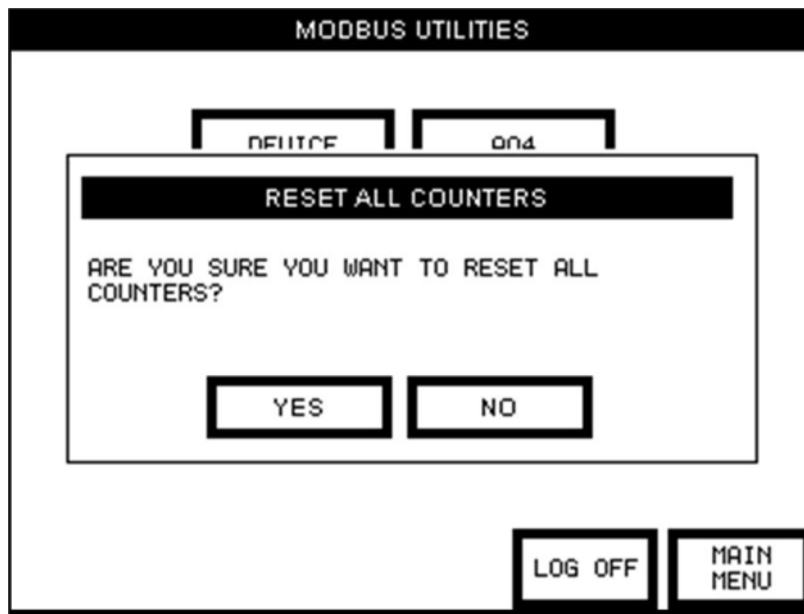

Figure 37 Reset All Counters Menu

5.4.3 Alarm Inhibit Screen

The Alarm Inhibit screen allows the user to inhibit alarms for a pre-determined amount of time. The screen is identified as 'ALARM INHIBIT'. The screen is typically used to inhibit alarms during calibration of a sensor.

When logged in, selecting the 'INHIBIT TIME' field will open a numeric keypad used to enter the length of time the controller will inhibit alarms. When the amount of time has been entered, select the 'START' button to start the time counter. The controller will inhibit all alarms until the time reaches '0' (zero). While the Alarm Inhibit counter is running, the field will display 'TIME REMAINING' along with the active counter. The 'START' button will change to a 'STOP' button which can be selected to exit alarm inhibit mode if the calibration is completed before the timer runs out or if alarm inhibit needs to be aborted for any other reason.

NOTE: The user must be logged in to the MCX-32 in order to make changes to the INHIBIT TIME field in the Alarm Inhibit screen and to be able to start the Alarm Inhibit counter.

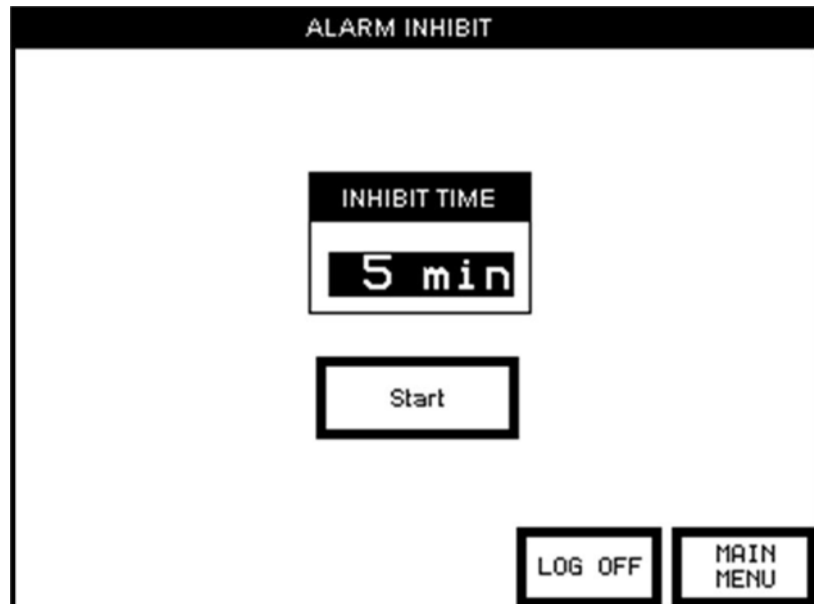

Figure 38 Alarm Inhibit Screen

If the Alarm Inhibit screen is exited while in alarm inhibit mode, the Main Display screen will show that the alarm inhibit function is on by displaying 'ALARM INHIBIT' at the top of the screen along with the active counter.

NOTE: From the Alarm Inhibit screen, the controller will return to the System Configuration screen after 1 minute of inactivity and then back to the Main Display screen after another minute of inactivity. This is normal. Pressing the 'ALARM INHIBIT' button will return to the Alarm Inhibit screen and the timer.

Upon power-up of the controller, the Alarm Inhibit function automatically becomes active and starts a two minute timer to prevent inadvertent alarms from occurring during initialization of any configured sensors. When the inhibit timer runs out, the controller will return to normal operation and alarms will no longer be inhibited. The user can enter the Alarm Inhibit screen at any time by pressing the 'ALARM INHIBIT' button and manually stop the alarm inhibit mode.

5.4.4 Turn ON/OFF Channels Screen

The Turn ON/OFF Channels screen allows selection of the number of active channels that the controller will be able to communicate with. Each channel can be turned on or off by selecting the corresponding channel button. Port 1 channels (1-32) are viewed separately from Port 2 channels (33-64) and can be displayed by selecting the appropriate 'VIEW PORT #' button located at the bottom of the screen. Channels can be

individually toggled on or off or they can all be turned on or off for each port by selecting the 'ALL ON' or 'ALL OFF' buttons located at the bottom of the screen.

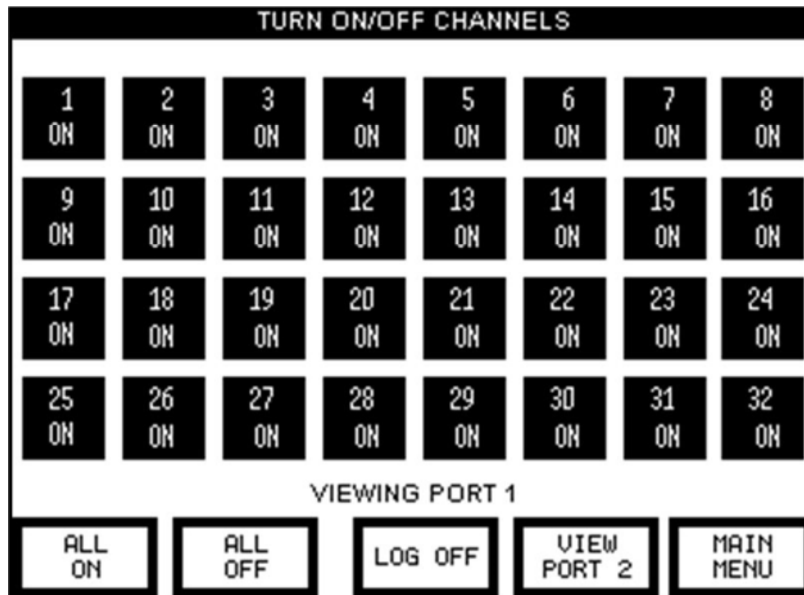

Figure 39 Turn ON/OFF Channels Screen

5.4.5 System Settings Screen

The System Settings screen contains six menu items that allow setting the time and date, adjustment of the screen contrast and brightness, the calibration of the touch screen panel, adjustment of automatic screen switching intervals, setting the Modbus address for the slave port and monitoring controller power supplies.

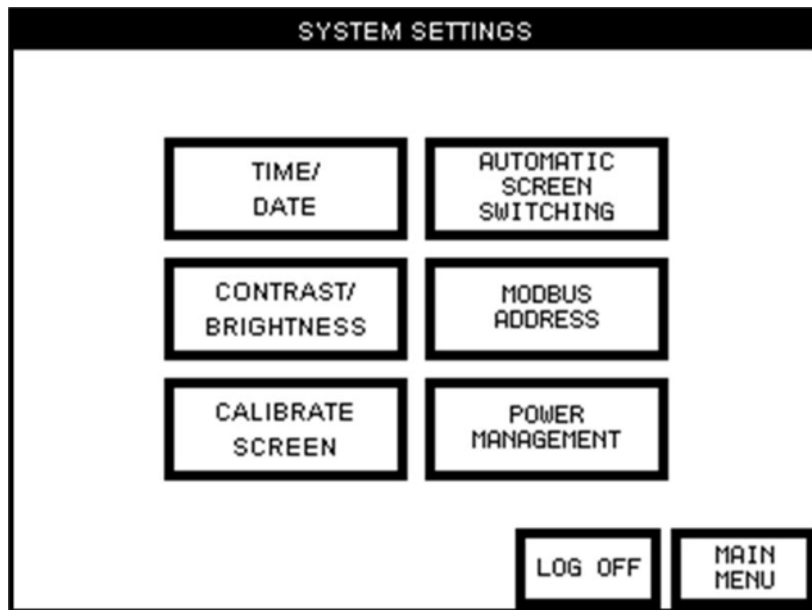

Figure 40 Display Settings

5.4.5.1 Time/Date Screen

The Time/Date screen allows the setting of the time and date. The time is displayed as military time (24hrs) in Hours:Minutes:Seconds. The date is displayed as Month/Day/Year. To change the value for the Time and

Date, simply select the value and then select 'ENTER' on the virtual keypad. The value to be changed will be highlighted. Use the keypad arrow keys labeled 'RAISE' and 'LOWER' to increase or decrease the value. Use the keypad arrow keys labeled 'PREV' and 'NEXT' to move to a different value. Select 'ENTER' to save the value.



Figure 41 Time/Date Screen

The Time Zone is based on Greenwich Mountain Time (GMT) and can be changed by selecting the time zone field and then using the keypad arrow keys labeled 'RAISE' and 'LOWER' to increase or decrease the value. Select 'ENTER' only after making a change to save the value.

For regions where Daylight Savings Time (DST) is observed, there is a DST menu button that turns daylight savings time ON or OFF when selected.

5.4.5.2 Automatic Screen Switching Screen

The Automatic Screen Switching menu allows the user to set the time interval (in seconds) for screen switching when the MCX-32 is in a normal state (no events such as alarms, comm errors or faults) or when there is an event such as an alarm state. This feature can also be turned ON or OFF from this menu. To change the interval value, select the appropriate field and use the displayed numeric keypad. Select 'ENTER' to save the value.

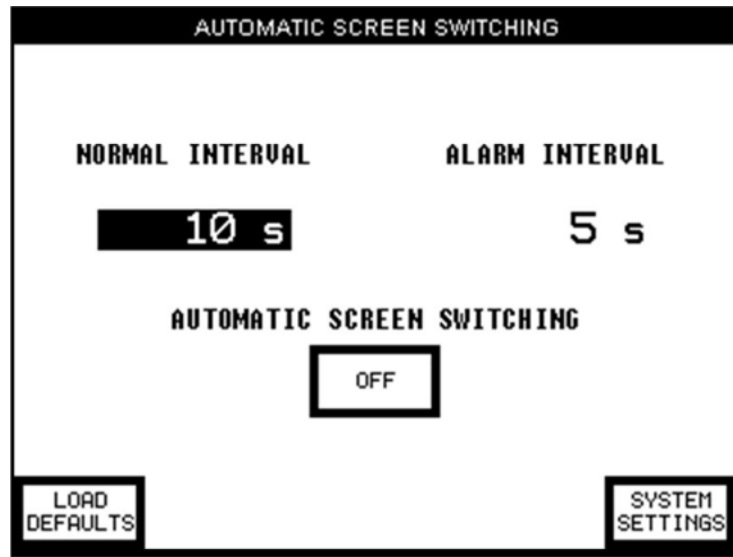

Figure 42 Automatic Screen Switching Screen

5.4.5.3 Contrast/Brightness Screen

The Contrast/Brightness menu allows the user to customize the contrast and brightness of the MCX-32 display. To change these values, select the appropriate field and use the displayed numeric keypad. Select 'ENTER' to save the value.

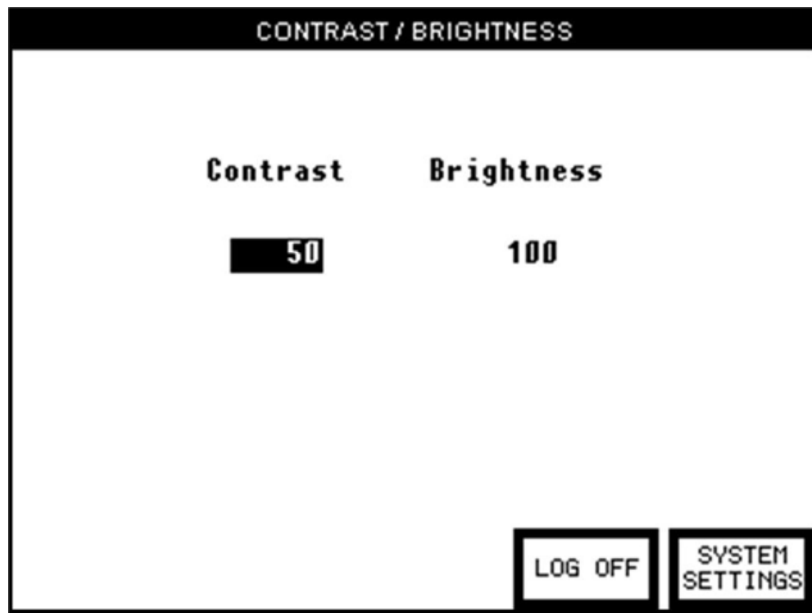

Figure 43 Contrast/Brightness Screen

5.4.5.4 Modbus Address Screen

The Modbus Address Screen allows the setting of the address used for the Slave RS-485 Port (Port 3). This address should normally be set for address 1, but can be changed via this screen by selecting the value and using the displayed numeric keypad. Select 'ENTER' to save the value.

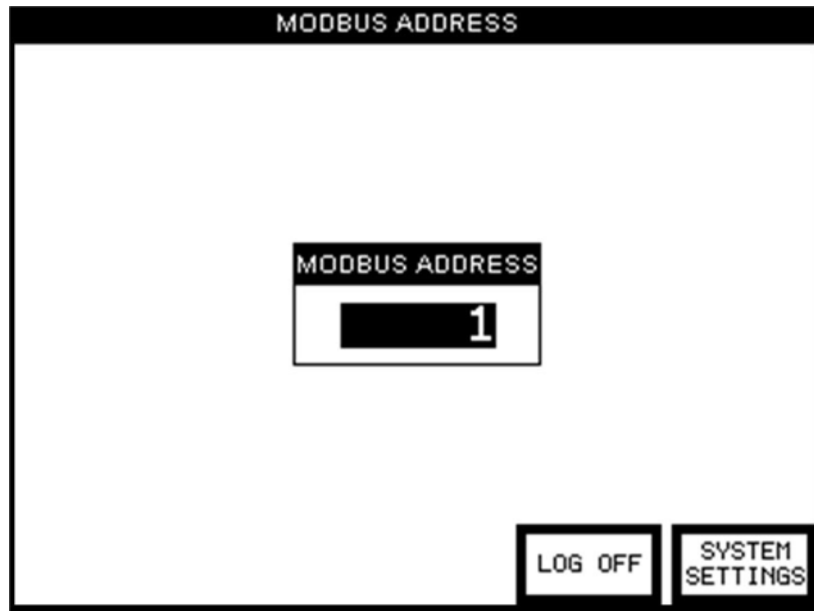

Figure 44 Modbus Address Screen

5.4.5.5 Calibration Screen

The Calibrate Screen menu allows the user to calibrate the MCX-32's touch screen display. Selecting this menu will launch the touch calibration application which instructs the user to touch the indicated squares accordingly. After a successful calibration, the application will close and exit back to the System Settings screen.

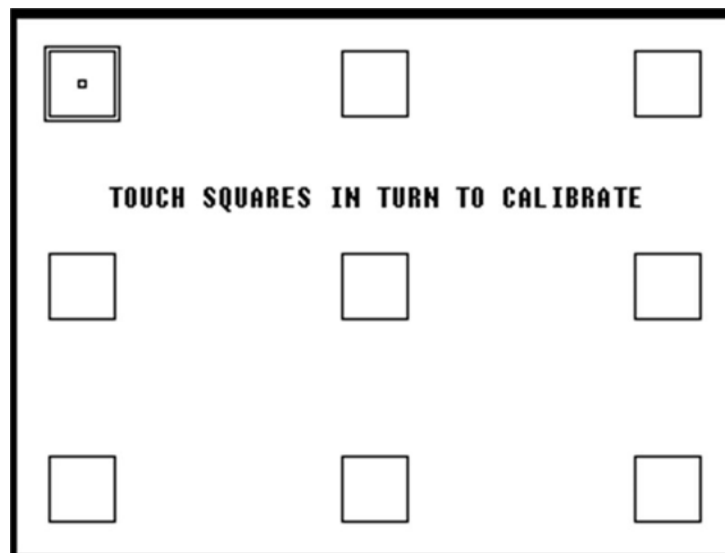

Figure 45 Calibration Screen

5.4.5.6 Power Management Screen

The controller has the ability to monitor the voltage from the internal power supply, and the auxiliary 24VDC input voltage to the controller. The Power Management screen provides a digital display of the voltages applied. If an auxiliary 24VDC is not connected to the controller, the voltage displayed will be correct for the primary, and the secondary will display 0.00. If an external power source is connected to the auxiliary 24VDC input, the secondary will display the applied voltage.

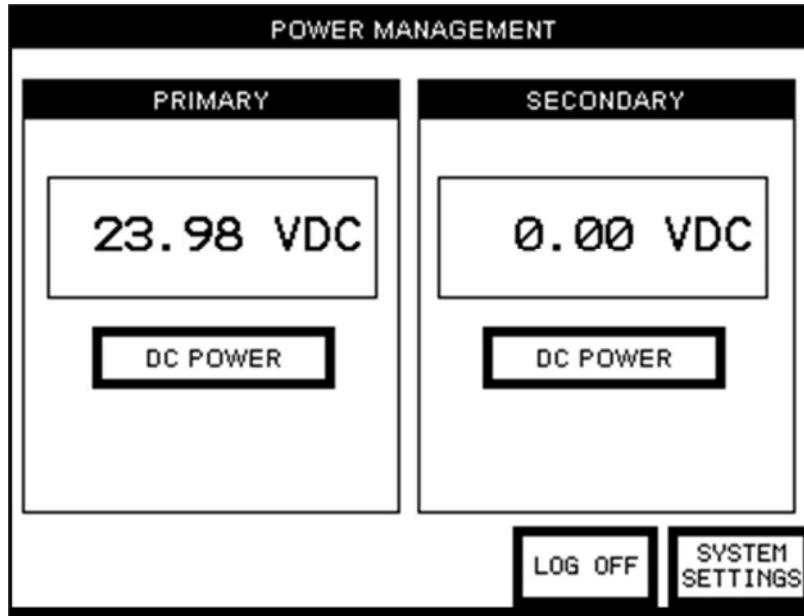

Figure 46 Power Management Screen (No Secondary Supply)

The controller has the unique ability to provide a charging voltage for approved rechargeable batteries. If batteries are connected to the auxiliary 24VDC input, this feature will provide a nominal 27VDC @ 1Amp (maximum) to the auxiliary 24VDC input to charge the batteries. The circuit will monitor the batteries and keep the batteries at full charge. Once the batteries have been connected to the auxiliary 24VDC input terminals, touch DC POWER on the secondary side of the screen to enable the MCX-32's battery charging circuitry. DC POWER will change to BATTERY which will enable the battery charging circuitry and apply the charging voltage to the auxiliary 24VDC input terminals.

NOTE: The battery charging feature *should not* be enabled for external 24VDC power sources or battery backup units that provide their own charging circuitry. Also, only approved rechargeable batteries must be used. Contact Detcon for more information regarding battery type.



WARNING: Switching the secondary from DC POWER to BATTERY with a hard line DC power source connected to the auxiliary 24VDC input may result in damage to the MCX-32 Controller. This also includes battery backup units that have their own charging circuitry.

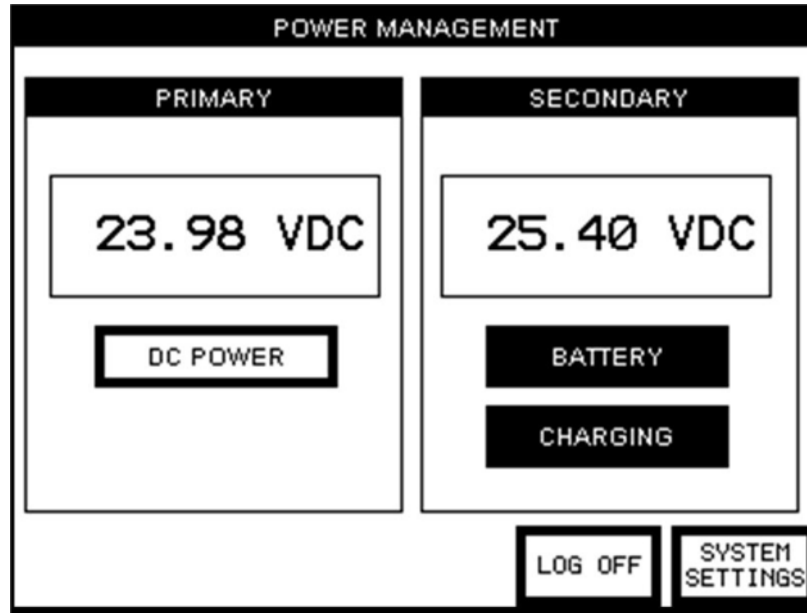

Figure 47 Power Management with Battery Charge ‘ON’

When the battery feature is selected, DC POWER will change to BATTERY and if the battery charging circuit senses that the batteries need charging, CHARGING will appear below BATTERY, and both will be highlighted. The voltage displayed on the Secondary side will then reflect the charging voltage provided to the batteries.

5.4.6 Restore Defaults Screen

When selected, this button will restore default values to all of the channel’s alarm set points, Modbus timeouts. This will not affect the channel description or other parameters pertaining to each channel.

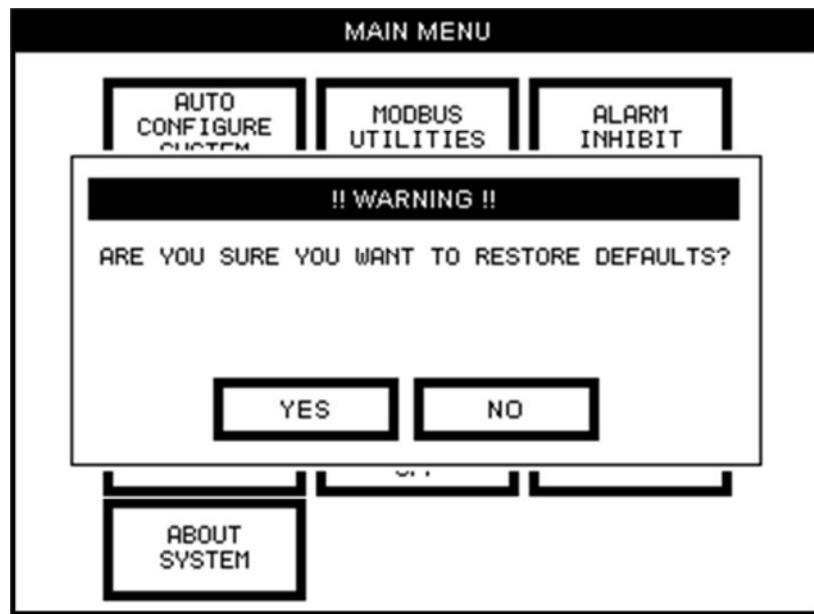

Figure 48 Restore Defaults Screen

5.4.7 Turn ON/OFF WTS

The Turn ON/OFF WTS screen allows selection of the number of active wireless transceivers that the controller will be able to communicate with. Each wireless transceiver corresponds to a specific channel number which defines the transceivers Modbus address. They can be turned ON or OFF by selecting the corresponding channel button associated with the transceiver. Port 1 transceivers (channels 1-32) are viewed separately from Port 2 transceivers (channels 33-64) and can be displayed by selecting the appropriate 'VIEW PORT #' button located at the bottom of the screen. Transceivers can be individually toggled ON or OFF or they can all be turned ON or OFF for each port by selecting the 'ALL ON' or 'ALL OFF' buttons located at the bottom of the screen.

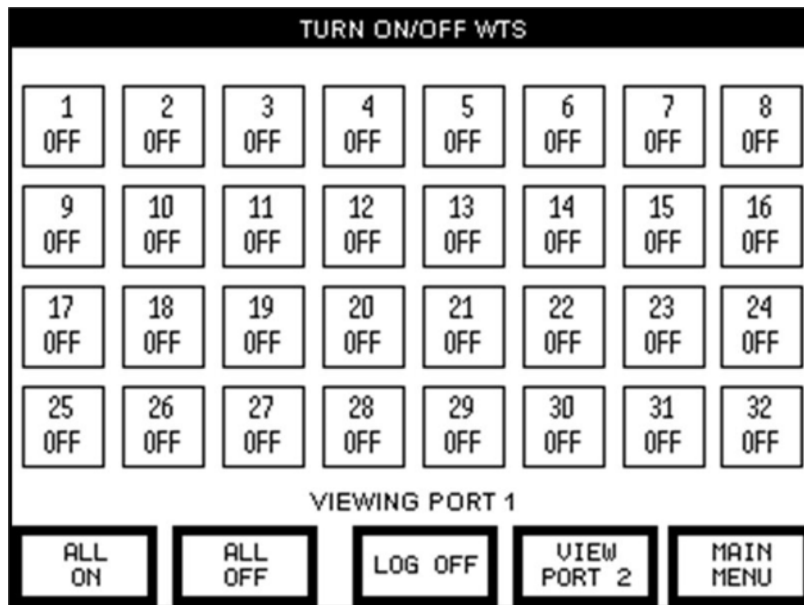

Figure 49 Turn ON/OFF WTS Screen

5.4.8 RL4/ALM STATION Setup Screen

The RL-4/ALM Station Setup screen is displayed when RL4/ALM STATION SETUP menu is selected. This screen allows manual configuration of the number of RL-4/Alarm stations in a particular bank and for a specific port. Port 1 contains 8 banks (Banks 1-8) and Port 2 contains another 8 banks (Banks 9-16). Two RL4/Alarm station Modbus addresses are supported per bank for a total of 32 possible RL4/Alarm stations with each port supporting Modbus addresses 80h-8Fh. The RL-4/Alarm station relay properties can also be configured from this screen, as well as the relay properties for the Auxiliary relays.

NOTE: The controller utilizes two RS-485 Ports (Port 1 and Port 2). Each port will support RL4/Alarm station addresses of 80h-8Fh. The RL-4/Alarm station must be connected to the port that their bank is assigned to. Failure to connect the alarm devices to the correct port will prevent the alarm devices from operating correctly.

NOTE: All RL-4/Alarm stations in a particular bank must be connected to the correct port their bank is assigned to. Banks 1-8 for Port 1 and Banks 9-16 for Port 2.

RL-4/Alarm devices must be addressed correctly and reside on the correct port for the controller to recognize them. Refer to Section 3.4 Alarm Relay Outputs (RL-4) for the correct addressing of RL-4/Alarm stations.

To activate an alarm device, simply select the correct Modbus address in the desired bank and port to turn it ON. This makes the specific address for the specific port available. Next, define the type of alarm device by selecting whether it is an RL4 module or an alarm station in the field below the Modbus address.

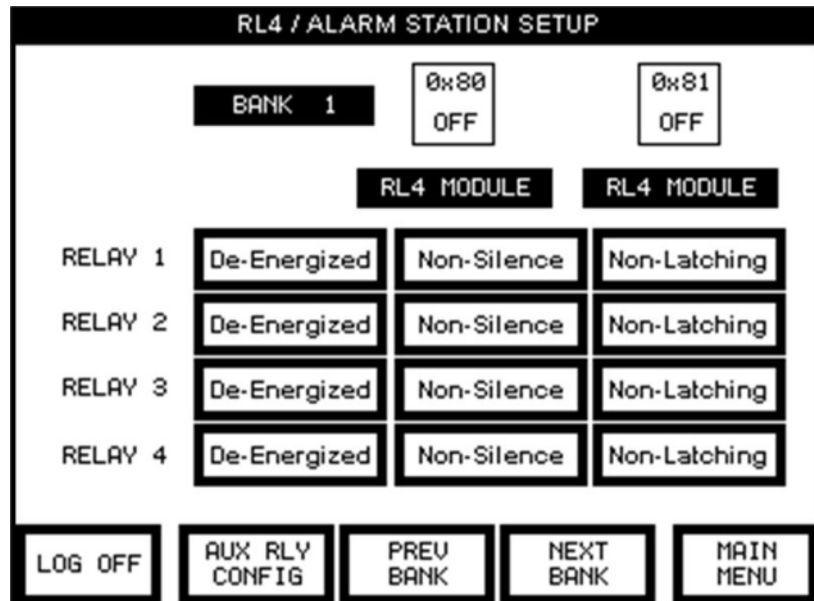

Figure 50 RL-4 Setup Screen

All four relays will be displayed for each bank. Each relay within the bank can be set as Energized/De-energized, Silence-able/Non-Silence-able, and Latching/Non-latching. Selecting the appropriate field will toggle that field between the two selections. Refer to Section 3.4 Alarm Relay Outputs (RL-4) for more information on these settings. Selecting the ‘NEXT BANK’ will go to the next bank and selecting ‘PREV BANK’ will go to the previous bank, where the same parameters can be set for that bank.

NOTE: There are 16 Banks of alarm relays. The bank of relays that a specific sensor is assigned to is selected from that sensor’s Channel Details screen. This screen also allows assigning alarm set points, and whether the set point is ascending or descending.

Auxiliary Relays

The Interface PCA contains two relays that can be configured and used for contact closure outputs for ‘FAULT’ and ‘NO-COMM’. The Fault Relay is set whenever there is a sensor fault, and the No-Comm relay is set when there is a communication error. Wiring to these relays should be brought directly to the Interface PCA. The Terminal Blocks on the Interface PCA are labeled NO1, C1, and NC1 for the NO-COMM relay, and NO2, C2, and NC2 for the FAULT relay. (NO – Normally Open Contact, C – Common Contact, and NC – Normally Closed Contact.) These relays may be setup as Energized or De-energized, Silence or Non Silence, and Latched or Unlatched by selecting the ‘AUX RLY CONFIG’ button located at the bottom of the RL4/Alarm Station Setup screen.

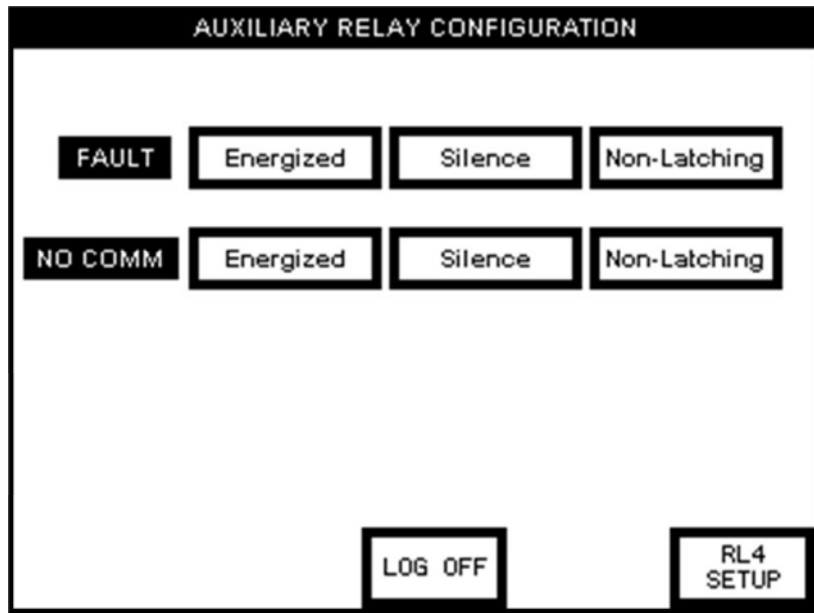

Figure 51 Auxiliary Relay Configuration Screen

5.4.9 Change Password Screen

The Change Password screen allows the user to change the password required to log in to the MCX-32 controller. When selected, the user is prompted to enter ‘Current Password’, ‘New Password’, and ‘Re-Type New Password’. Passwords are numeric values ten digits or less.

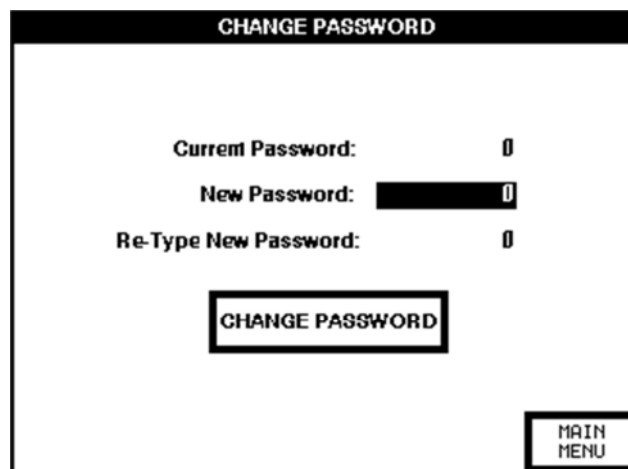

Figure 52 Change Password Screen

After successfully inputting the current password, the user will enter a new password and then re-type that new password. The user will then select the ‘CHANGE PASSWORD’ button and if the new password and the re-typed password are the same, the new password will take effect and will need to be used to log in to the controller.

5.4.10 WT Setup Screen

The WT Setup screen contains two menus that are used to set low battery alarm thresholds for wireless transceivers using Detcon’s Smart Battery Pack and to set RF silence and sleep command parameters.

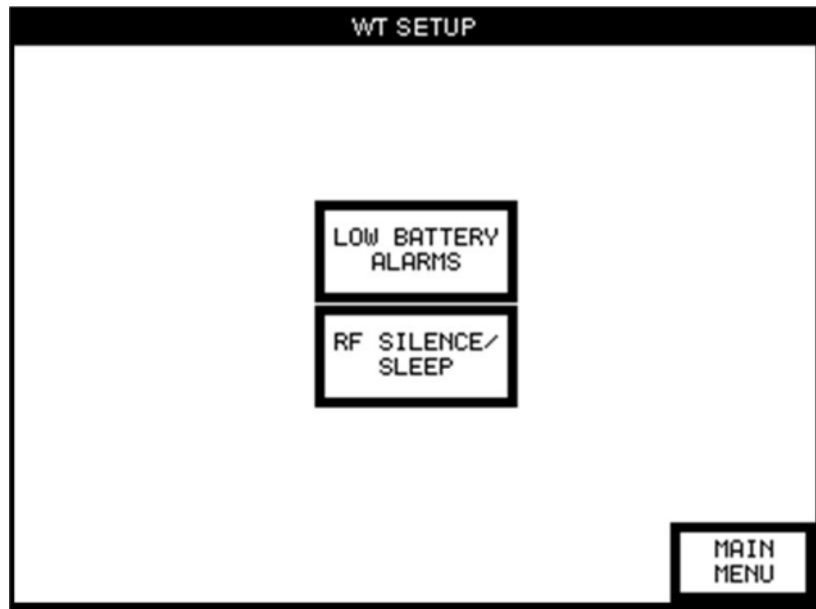

Figure 53 WT Setup Screen

5.4.10.1 Low Battery Alarms Screen

The Low Battery Alarms menu allows the user to set low battery alarm thresholds for wireless transceivers using Detcon’s Smart Battery Pack that are interfaced to the MCX-32. TTE represents the time to empty and is displayed in days. SOC represents the state of charge and is displayed as a percentage value. The TTE value is used for wireless transceivers interfaced to devices other than alarm stations. The SOC value applies to alarm stations only. A low battery status will appear on the display corresponding to the wireless transceiver with the low battery when the battery life reaches the set threshold.

CXT sensors which use disposable batteries instead of smart batteries will display the battery voltage only since TTE cannot be determined.

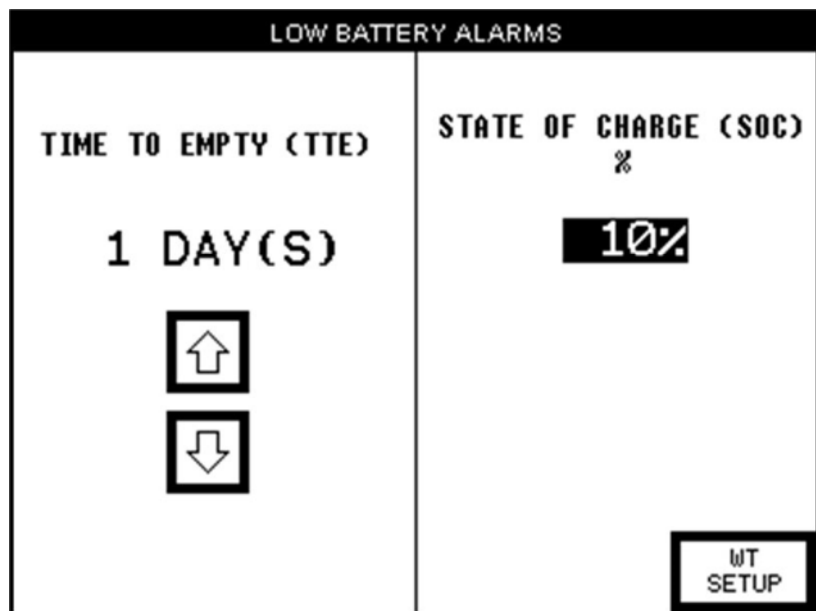

Figure 54 Low Battery Alarm Screen

The low battery threshold for these type of transceivers is set at 6.00V from the factory and a low battery status will appear on the display corresponding to the CXT transceiver when its battery voltage reaches 6.00V. Contact Detcon for instructions on how to change this threshold.

To change the TTE value, simply select the up or down arrow accordingly. To change the SOC value, select the SOC field and use the numeric keypad to change the value. Select 'ENTER' to save the value.

5.4.10.2 RF Silence/Sleep Screen

The RF Silence/Sleep menu allows the user to initiate radio silence over the whole network and to set sleep command intervals to use as a power saving feature.

RF or radio silence terminates communication between all the wireless transceivers in the network for an indefinite amount of time until the user turns the function OFF. RF silence is used to prevent the radios from possibly interfering with other RF devices on site (such as remote detonators). Once set to ON, it will stay on until the user turns it OFF.

RF sleep is a function that lets the MCX-32 controller broadcast a sleep command to all wireless transceivers in the network. When sleep is enabled, the devices are each polled once, and then the wireless transceivers are turned off for the set sleep period. Once the sleep period expires, the transceivers are turned back on and the devices are polled once more. This cycle repeats indefinitely. During sleep, the devices are not updated and the alarms are not activated. The longer the sleep time, the longer the possible delay between alarm conditions occurring and the alarms being activated. However, a longer sleep period will increase the battery run time.

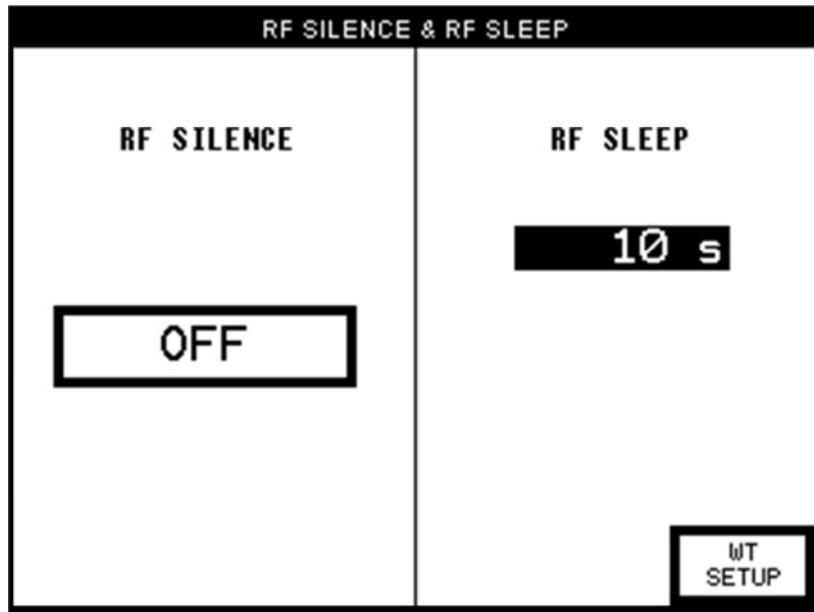

Figure 55 RF Silence and RF Sleep Screen

RF Silence can be toggled ON or OFF by selecting the appropriate RF Silence field. To set the RF Sleep value, select the RF Sleep field and use the numeric keypad to change the value. Select 'ENTER' to save the value.

5.4.11 Alarm Test Mode Screen

When selected, ALARM TEST MODE menu button will simulate alarm conditions by incrementing the gas readings from 0 for all active gas channels at 5% full scale. Once the concentration has reached full scale, the concentration will begin to decrement back to 0 and the controller will exit the test mode. The test mode can also be terminated at any time during the test cycle by selecting the ALARM TEST MODE menu button again.

ALARM TEST						MCX-32 16:29:45	
1	2	3	4	5	6	7	8
CH-01	HUD PUMP ROOM	25	PPH H2SCO	A1	A2		
CH-02	DRILL FLOOR	25	PPH H2S	A1	A2		
CH-03	HUD TANK EAST	25	PPH CO	A1	A2		
CH-04	HELL BAY WEST	25	PPH HCN	A1	A2		
CH-05	SHALE SHAKER	25	% CL2	A1	A2		
CH-06	STARBOARD MOON POOL	25	% NH3	A1	A2		
CH-07	GENERATOR ROOM	25	% LEL	A1	A2		
CH-08	HUD PITS	25	PPH SO2	A1	A2		

Figure 56 Alarm Test Mode

As the readings cross their respective ALM1, ALM2, and ALM3 set points, the relays will fire according to their configuration. The on/off status of the test will be indicated on the ALARM TEST MODE menu button as well as on the main display which will display ALARM TEST at the top when the function is active.

5.4.12 Compact Flash Screen

The Compact Flash screen allows the user to view data logging files from the Compact Flash (CF) card if one is installed. The user can also reset (delete) data logging files and save & load controller configurations from this screen. This screen is displayed by selecting the COMPACT FLASH menu button from the System Configuration screen.

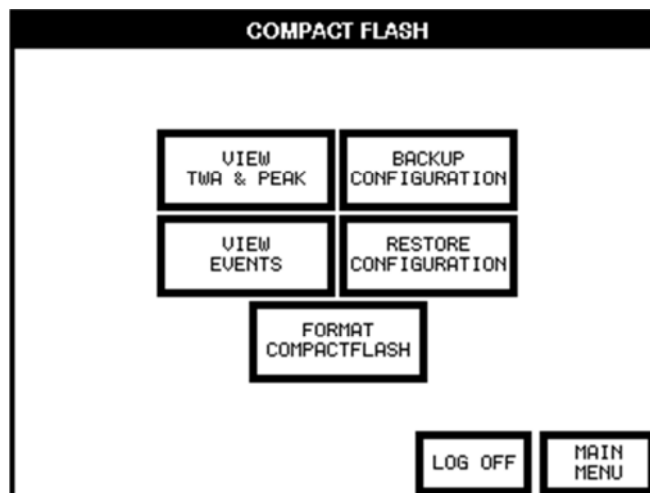

Figure 57 Compact Flash Screen

5.4.12.1 View TWA & Peak Screen

Selecting the VIEW TWA & PEAK button displays the TWA & PEAK screen which allows the user to view the recorded time weighted average (TWA) and peak readings for each channel represented by its assigned gas sensor. This data is calculated and recorded every 60 minutes and is displayed on the screen with the date, time, channel number, TWA and peak readings. The user can scroll through the recorded data of a specific date in increments of 10 or 100 by selecting the buttons on the right of the screen accordingly. The user can also page back and forth to different dates by selecting the buttons on the bottom of the screen labeled 'PREV DAY' and 'NEXT DAY'.

TWA & PEAK				
DATE	TIME	CH	AVERAGE	PEAK
12/27/12	22:41:52	37	0	0
12/27/12	22:41:52	38	0	0
12/27/12	22:41:52	39	0	0
12/27/12	22:41:52	40	0	0
12/27/12	22:41:52	41	0	0
12/27/12	22:41:52	42	0	0
12/27/12	22:41:52	43	0	0
12/27/12	22:41:52	44	0	0
12/27/12	22:41:52	45	0	0
12/27/12	22:41:52	46	0	0

-100

-10

+10

+100

LOG OFF

PREV DAY

NEXT DAY

COMPACT FLASH

Figure 58 TWA & PEAK Screen

5.4.12.2 View Events

Selecting the VIEW EVENTS button displays the EVENTS screen which allows the user to view recorded events such as alarms, faults, comm errors, alarm inhibits, etc. This data is recorded every time the controller detects a defined event and is displayed on the screen with the date, time, channel number (if applicable) and corresponding event. The user can scroll through the recorded events of a specific date in increments of 10 or 100 by selecting the buttons on the right of the screen accordingly. The user can also page back and forth to different dates by selecting the buttons on the bottom of the screen labeled 'PREV DAY' and 'NEXT DAY'.

EVENTS			
DATE	TIME	CH	EVENT
12/12/12	20:53:36	04	FAULT ON
12/12/12	20:53:37	04	COMM ERROR OFF
12/12/12	20:56:15	--	POWER ON
12/12/12	20:56:15	--	ALM INHBT ON
12/12/12	20:56:18	04	FAULT ON
12/12/12	20:56:27	--	ALM INHBT OFF
12/12/12	20:57:04	04	COMM ERROR ON
12/12/12	20:57:04	04	FAULT OFF
12/12/12	20:57:05	04	COMM ERROR ON
12/12/12	21:04:54	12	COMM ERROR ON

-100

-10

+10

+100

LOG OFF

PREV DAY

NEXT DAY

COMPACT FLASH

Figure 59 Events Screen

5.4.12.3 Backup Configuration Screen

The BACKUP CONFIGURATION button allows the user to save the current configuration of the MCX-32 to the CF card.

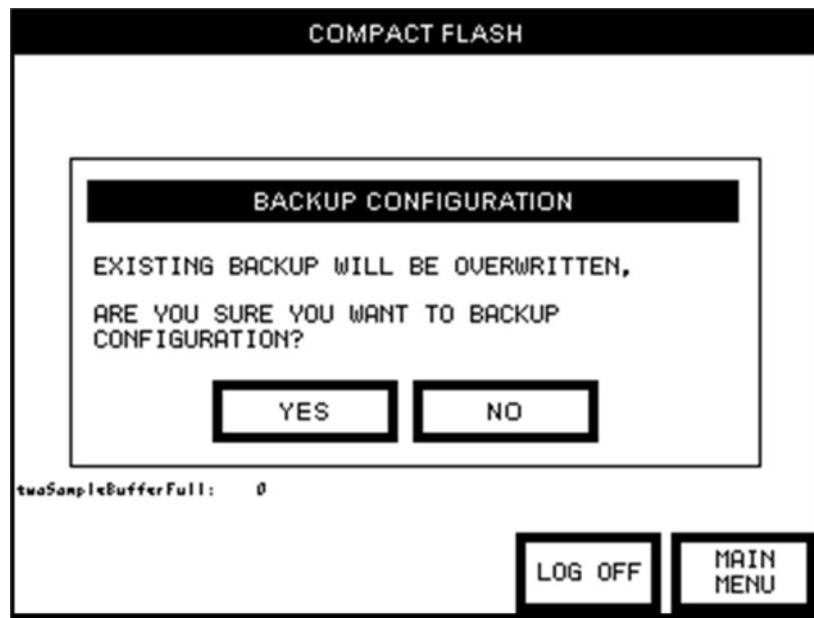

Figure 60 Backup Configuration Screen

5.4.12.4 Restore Configuration Screen

The RESTORE CONFIGURATION button allows the user to load the saved configuration stored in the CF card. This allows for greater portability to other MCX-32 controllers that require similar configurations.

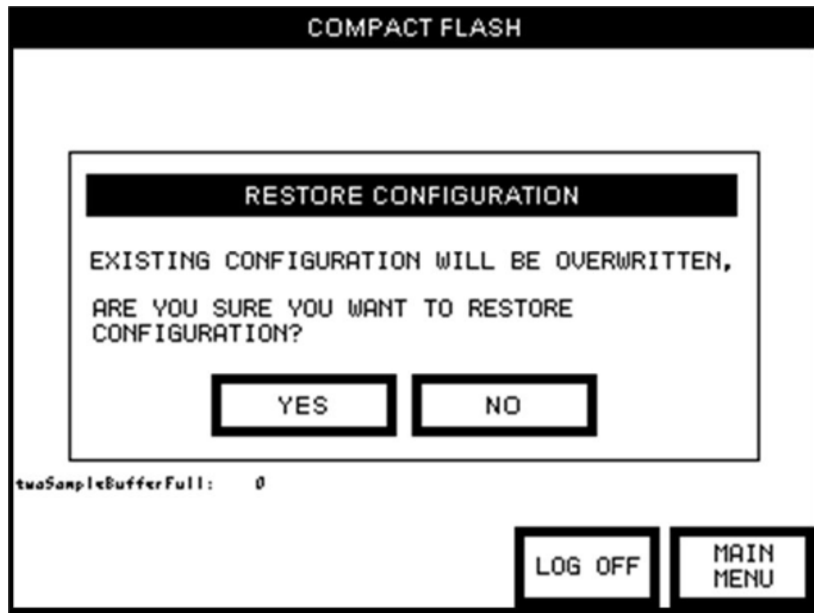

Figure 61 Restore Configuration Screen

5.4.12.5 Format Compact Flash Screen

The CF card is automatically formatted upon power up of the MCX-32 controller which creates the necessary files for data logging. The FORMAT COMPACTFLASH button allows the user to reset (delete) all data stored in these logging files. When selected, a warning window will be displayed prompting the user to confirm the reset of the CF card. Selecting the ‘YES’ button will erase all the data recorded up to this point and initiate the recording of new data. Selecting the ‘NO’ button will cancel the reset and no data will be deleted from the logging files.

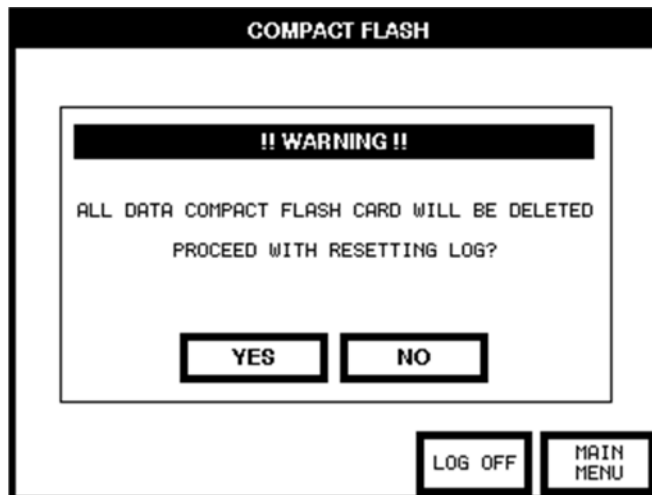

Figure 62 Format CompactFlash Warning Window

NOTE: Do not remove or insert the CompactFlash card while power is applied.

The data can also be viewed by removing the CF card and inserting it in a laptop using the Detcon Log File Viewer application. Refer to the Detcon Log File Viewer instruction manual for more information.

5.4.13 About System Screen

The About System screen displays important information about the MCX-32 controller including its IP address if connected to a LAN.

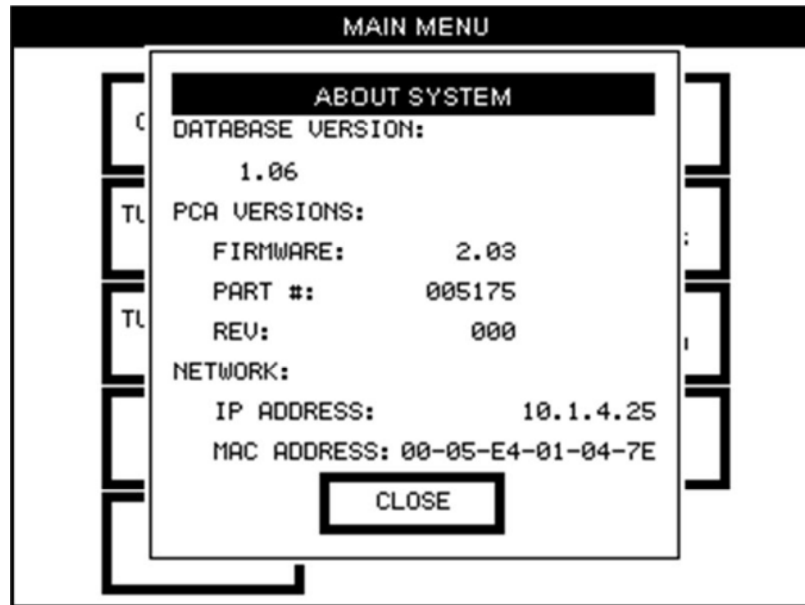

Figure 63 About System Screen

6.0 Controller Setup

The setup of the controller is critical for proper operation. Modbus™ addresses must be correct on all the devices connected to the controller before the controller will acknowledge them. If manually configured, the number of sensors and wireless transceivers, if any, must be entered into the controller to allow it to communicate with them. Alarm devices must be enabled on the correct port before they can be utilized. The following basic areas need to be configured:

- The number of sensors must be determined before setup begins and configured on the Turn ON/OFF Channels screen or an auto configure must be performed.
- The number of wireless transceivers must be determined before setup begins and configured on the Turn ON/OFF WTS screen or an auto configure must be performed.
- The number of 4-20mA inputs must be determined before setup begins and configured accordingly or an auto configure must be performed.
- If 4-20mA outputs are required, they must be set up and enabled or an auto configure must be performed.
- Relay modules/alarm stations must be set-up correctly or an auto configure must be performed.
- The sensor's Channel Details must be configured to match the sensor connected.
- The wireless transceiver's WT Details must be configured to match the transceiver connected.

The MCX-32 has the distinct ability to poll a network of serial devices, read and store most of the configuration information for those devices that it detects. This time saving 'Auto Configure System' ability will work with Detcon Model 100, 600C, 600D, 700, CXT320, RXT320 sensors/devices, DA4 modules, DI4 modules, RL4 modules, AO4 modules and RXT320 analog inputs that are interfaced to the controller. Any device not found by the Auto Configure function will need to be configured manually. Use Table 6 and Table 7 below as a quick reference guide for channel assignments of specific input devices and their corresponding Modbus addresses for Port 1 and Port 2.

Table 6 Input Device Modbus™ Addresses for Port 1

PORT	CHANNEL	SERIAL SENSORS (Hex)	Wireless Sensors (Hex)	DA4/DI4 & CX INPUTS (Hex)	RXT ANALOG INPUTS (Hex)
1	1	1	1	40	1
	2	2	2	40	1
	3	3	3	40	2
	4	4	4	40	2
	5	5	5	41	3
	6	6	6	41	3
	7	7	7	41	4
	8	8	8	41	4
	9	9	9	42	5
	10	A	A	42	5
	11	B	B	42	6
	12	C	C	42	6
	13	D	D	43	7
	14	E	E	43	7
	15	F	F	43	8
	16	10	10	43	8
	17	11	11	44	9
	18	12	12	44	9
	19	13	13	44	A
	20	14	14	44	A
	21	15	15	45	B
	22	16	16	45	B
	23	17	17	45	C
	24	18	18	45	C
	25	19	19	46	D
	26	1A	1A	46	D
	27	1B	1B	46	E
	28	1C	1C	46	E
	29	1D	1D	47	F
	30	1E	1E	47	F
	31	1F	1F	47	10
	32	20	20	47	10

Table 7 Input Device Modbus™ Addresses for Port 2

PORT	CHANNEL	SERIAL SENSORS (Hex)	Wireless Sensors (Hex)	DA4/DI4 & CX INPUTS (Hex)	RXT ANALOG INPUTS (Hex)
2	33	21	21	48	21
	34	22	22	48	21
	35	23	23	48	22
	36	24	24	48	22
	37	25	25	49	23
	38	26	26	49	23
	39	27	27	49	24
	40	28	28	49	24
	41	29	29	4A	25
	42	2A	2A	4A	25
	43	2B	2B	4A	26
	44	2C	2C	4A	26
	45	2D	2D	4B	27
	46	2E	2E	4B	27
	47	2F	2F	4B	28
	48	30	30	4B	28
	49	31	31	4C	29
	50	32	32	4C	29
	51	33	33	4C	2A
	52	34	34	4C	2A
	53	35	35	4D	2B
	54	36	36	4D	2B
	55	37	37	4D	2C
	56	38	38	4D	2C
	57	39	39	4E	2D
	58	3A	3A	4E	2D
	59	3B	3B	4E	2E
	60	3C	3C	4E	2E
	61	3D	3D	4F	2F
	62	3E	3E	4F	2F
	63	3F	3F	4F	30
	64	40	40	4F	30

For example, assuming the following input devices are to be configured on Port 1:

- 1 Wired IR-700 Serial Sensor
- 1 CXTDM Sensor
- 1 RXT w/ DM-100 Serial Sensor
- 1 RXT w/ One Analog Input Sensor, 1 RXT w/ Two Analog Input Sensors
- 1 DA4 w/ Two Analog Input Sensors, 1 DA4 w/ Four Analog Input Sensors
- 1 CX Site Sentinel w/One Analog Input Sensor, 1 CX Site Sentinel w/Three Analog Input Sensors

There are multiple ways to configure these devices and assign channels and Modbus addresses accordingly. However, it is recommended to configure RXT analog inputs first, followed by DA4 inputs and CX Site Sentinels and lastly wireless and wired serial sensors. The following Table 8 shows a valid configuration for the input devices from the example.

Table 8 Input Device Configuration Example for Port 1

CHANNEL	CHANNEL STATUS	INPUT DEVICE	DEVICE TYPE	MODBUS ADDRESS (Hex)	WTS ON/OFF Page
1	ON	RXT w/Analog Sensor 1	RXT Analog	01	1
2	OFF	N/A	N/A	N/A	N/A
3	ON	RXT w/Analog Sensor 1	RXT Analog	02	2
4	ON	RXT w/Analog Sensor 2	RXT Analog	02	2
5	ON	DA4 w/Analog Sensor 1	DA4	41	N/A
6	ON	DA4 w/Analog Sensor 2	DA4	41	N/A
7	OFF	N/A	N/A	N/A	N/A
8	OFF	N/A	N/A	N/A	N/A
9	ON	DA4 w/Analog Sensor 1	DA4	42	N/A
10	ON	DA4 w/Analog Sensor 2	DA4	42	N/A
11	ON	DA4 w/Analog Sensor 3	DA4	42	N/A
12	ON	DA4 w/Analog Sensor 4	DA4	42	N/A
13	ON	CX w/Analog Sensor 1	CX Sensor Station	43	3
14	OFF	N/A	N/A	N/A	N/A
15	OFF	N/A	N/A	N/A	N/A
16	OFF	N/A	N/A	N/A	N/A
17	ON	CX w/Analog Sensor 1	CX Sensor Station	44	4
18	ON	CX w/Analog Sensor 2	CX Sensor Station	44	4
19	ON	CX w/Analog Sensor 3	CX Sensor Station	44	4
20	OFF	N/A	N/A	N/A	N/A
21	ON	CXTDM Sensor	CXT 320	15	21
22	ON	RXT w/DM100 Serial Sensor	100	16	22
23	ON	Wired IR700 Serial Sensor	700	17	N/A

The RXT with one analog input sensor is assigned Modbus address 01h which corresponds to Channel 1 and Channel 2 for an RXT Analog device type. Channel 1 will display the information of an analog sensor connected to the first analog input of the RXT via AN1 of the Model 100 Terminal Board. Channel 2 will display the information of an analog sensor connected to the second analog input of the RXT via AN2 of the Model 100 Terminal Board. In this example, only one analog sensor is interfaced to this RXT which should be connected to its first analog input, thus its information will be displayed on Channel 1. Channel 2 is turned OFF since a second analog sensor is not interfaced to this RXT. Additionally, since this is a wireless device, the transceiver needs to be turned ON accordingly in the WTS ON/OFF page to access the transceivers information which corresponds to WTS 1 based on its Modbus address of 01h. Refer to section 3.8 RXT-320 Wireless transceiver Analog Inputs for more detailed information.

The RXT with two analog input sensors is assigned Modbus address 02h which corresponds to Channel 3 and Channel 4 for an RXT Analog device type. Channel 3 will display the information of the analog sensor connected to the first analog input of the RXT via AN1 of the Model 100 Terminal Board. Channel 4 will display the information of the analog sensor connected to the second analog input of the RXT via AN2 of the Model 100 Terminal Board. Additionally, since this is a wireless device, the transceiver needs to be turned ON accordingly in the WTS ON/OFF page to access the transceivers information which corresponds to WTS 2 based on its Modbus address of 02h. Refer to section 3.8 RXT-320 Wireless transceiver Analog Inputs for more detailed information.

The DA4 with two analog input sensors is assigned Modbus address 41h which corresponds to Channel 5, Channel 6, Channel 7 and Channel 8 for a DA4 device type. If the analog sensors are connected to Input 1 and Input 2 of the DA4, these correspond to Channel 5 and Channel 6 respectively and will display the sensors information accordingly. Since Input 3 and Input 4 of the DA4 are not used, their respective Channel 7 and Channel 8 are turned OFF. Since this is not a wireless device, there is no WTS to be turned ON from the WTS ON/OFF page. Refer to section 3.1 Analog 4-20mA Sensor Inputs (DA-4).

The DA4 with four analog input sensors is assigned Modbus address 42h which corresponds to Channel 9, Channel 10, Channel 11 and Channel 12 for a DA4 device type. These channels will display the information of the analog sensors connected to all four of the DA4 inputs respectively. Since this is not a wireless device, there is no WTS to be turned ON from the WTS ON/OFF page. Refer to section 3.1 Analog 4-20mA Sensor Inputs (DA-4) for more detailed information.

The CX Site Sentinel with one analog input sensor is assigned Modbus address 03h on its wireless transceiver and Modbus address 43h on its analog input PCA which corresponds to Channel 13, Channel 14, Channel 15 and Channel 16 for a CX Sentinel device type. If the analog sensor is connected to Input 1 of the CX Sentinel, this corresponds to Channel 13 which will display the sensor's information accordingly. Since Input 2, Input 3 and Input 4 of the CX Sentinel are not used, their respective Channel 14, Channel 15 and Channel 16 are turned OFF. Additionally, since this is a wireless device, the transceiver needs to be turned ON accordingly in the WTS ON/OFF page to access the transceiver's information which corresponds to WTS 3 based on the transceiver's Modbus address of 03h. Refer to section 3.9 SmartWireless® CXT Sentinel Slave Controller for more detailed information.

The CX Site Sentinel with three analog input sensors is assigned Modbus address 04h on its wireless transceiver and Modbus address 44h on its analog input PCA which corresponds to Channel 17, Channel 18, Channel 19 and Channel 20 for a CX Sentinel device type. If the analog sensors are connected to Input 1, Input 2 and Input 3 of the CX Sentinel, these correspond to Channel 17, Channel 18 and Channel 19 which will display the sensor's information accordingly. Since Input 4 of the CX Sentinel is not used, its respective Channel 20 is turned OFF. Additionally, since this is a wireless device, the transceiver needs to be turned ON accordingly in the WTS ON/OFF page to access the transceiver's information which corresponds to WTS 4 based on the transceiver's Modbus address of 04h. Refer to section 3.9 SmartWireless® CXT Sentinel Slave Controller for more detailed information.

The CXTDM sensor is assigned Modbus address 15h which corresponds to Channel 21 for a CXT 320 device type. Channel 21 will display the information for the CXTDM sensor accordingly. Additionally, since this is a wireless device, the transceiver needs to be turned ON accordingly in the WTS ON/OFF page to access the transceivers information which corresponds to WTS 21 based on its Modbus address of 15h. Refer to section 3.7 Wireless RXT-320 Modbus™ Devices and CXT-320 Sensors for more detailed information.

The RXT w/ DM100 serial sensor is assigned Modbus address 16h which corresponds to Channel 22 for a 100 device type. Channel 22 will display the information for the DM100 sensor accordingly. Additionally, since this is a wireless device, the transceiver needs to be turned ON accordingly in the WTS ON/OFF page to access the transceivers information which corresponds to WTS 22 based on its Modbus address of 16h. Refer to section 3.7 Wireless RXT-320 Modbus™ Devices and CXT-320 Sensors for more detailed information.

The wired IR700 serial sensor is assigned Modbus address 17h which corresponds to Channel 23 for a 700 device type. Channel 23 will display the information for the IR700 sensor accordingly. Since this is not a wireless device, there is no WTS to be turned ON from the WTS ON/OFF page. Refer to section 3.6 Serial Output Gas Sensors (RS-485) for more detailed information.

6.1 Sensor Channel Setup

When a sensor is being added to the controller, information for that sensor will need to be added or modified on the Channel Details screen. The Channel Details screen is used to view or change information directly related to a sensor. The Channel Details screen also displays the sensor’s current reading, the units/gas type, if the channel is on or off, the life of the sensor, the range of the sensor, the analog output status, the sensor type, the current sensor status, the alarm thresholds and the RL4 banks. Many of the variables can be changed on this screen.

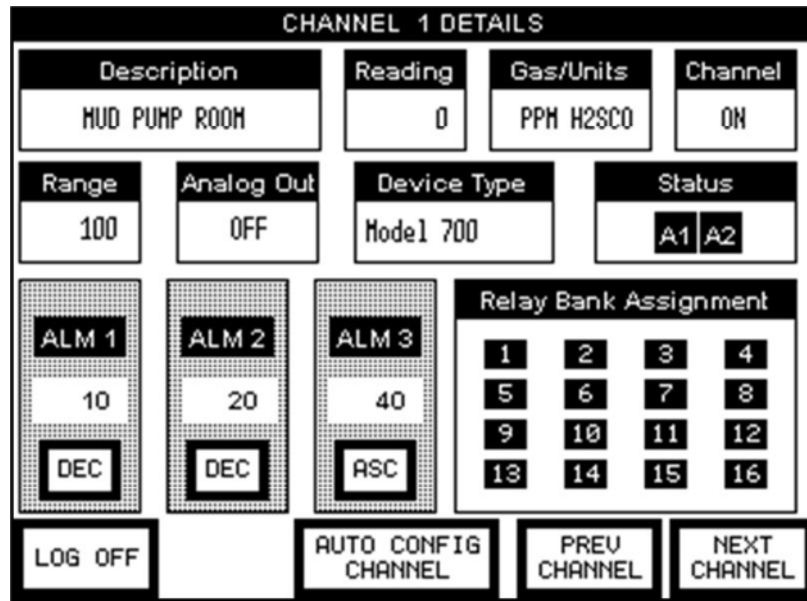

Figure 64 Channel Details Screen

If a channel is off, this screen will display the channel being annotated as ‘OFF’.

A sensor can be added to the controller’s configuration in one of two ways:

1. On the Channel Details screen, the AUTO CONFIG CHANNEL button may be selected. This will cause the controller to poll for a serial sensor addressed at that channel on the Modbus™. If a sensor is located, the controller will populate that channel with the information obtained from the sensor.

- The sensor/device can be input manually by selecting the Device Type. This will open a window that will allow the user to select the type of device that is being attached (Figure 68). The controller will then try to communicate with the appropriate sensor or I/O module.

After a channel is added, the information on the Channel Details screen will need to be checked and/or updated to insure that the configuration for that sensor is correct and accurate.

Description

On the Channel Details screen, select the ‘Description’ field to modify the contents of that field. This will open an on-screen keyboard, which is used to enter the alphanumeric information that will be used as the sensor’s description.

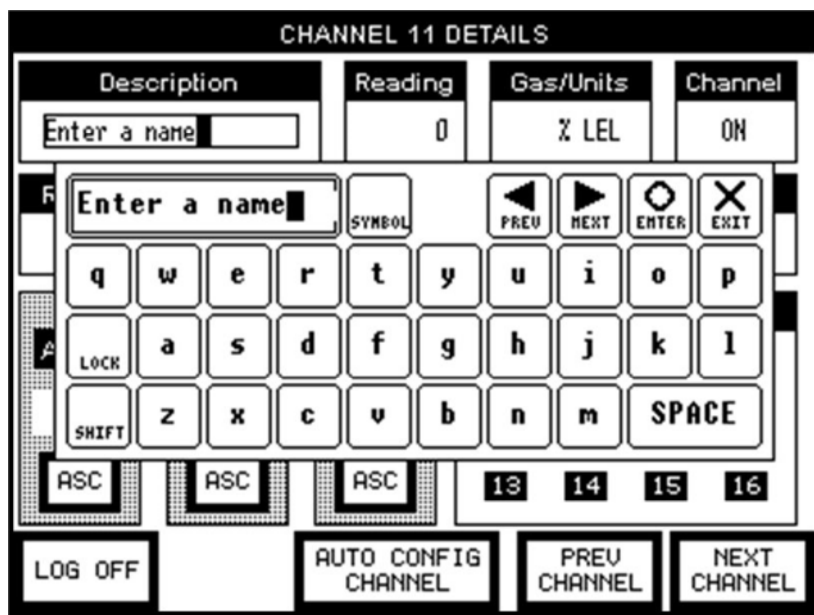

Figure 65 Channel Description Entry

Reading

The Reading is read directly from the sensor or I/O Module, and cannot be changed.

Gas/Units

The Gas/Units field should be set accordingly for the sensor attached. For serial sensors that have been found during an Auto Configure, this information should be correct. For other types of sensors, this information should be set manually. To change the information, select the Gas/Units field on the screen. The controller will respond with a screen input keyboard. Enter the correct units and gas type for the sensor connected, and press “enter” to accept the value. This value is an alphanumeric label, and is used only for identification of the type of gas being detected. This information should match the sensor that is connected to the channel.

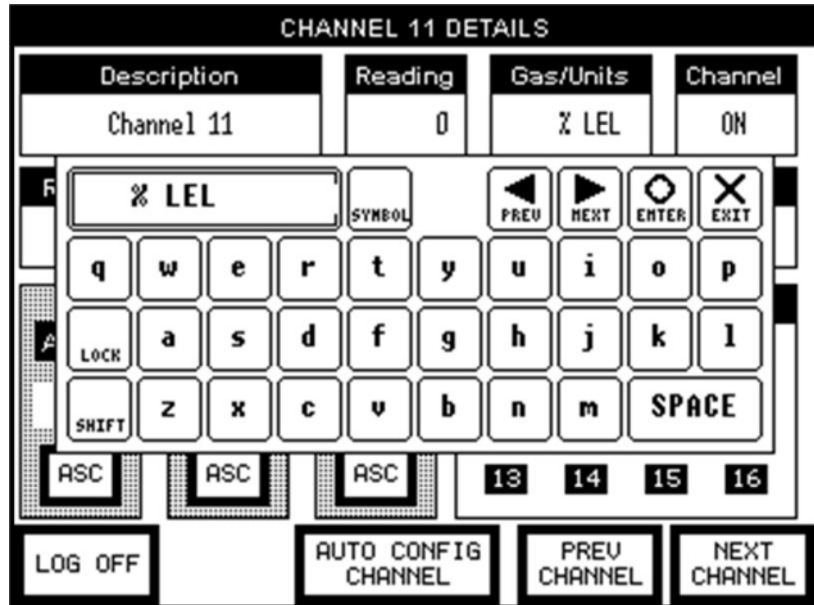

Figure 66 Gas/Units Entry

Channel (ON/OFF)

The Channel field is used to turn the channel 'ON' or 'OFF'. If the Channel field is 'OFF', the controller will not attempt to communicate with a sensor or I/O Module connected to the channel. This is useful if the sensor is not working properly and needs to be removed from being polled. Note that the channel is not actually removed from the configuration, but is only disabled. Turning the channel back 'ON' will restore the configuration information that was previously stored.

Range

The Range cannot be changed if the sensor information was obtained during the Auto Configure System or the Auto Config Channel was used to obtain sensor information. If the sensor is connected through a DA-4 I/O Module or RXT analog input, the range must be entered for proper operation. To enter the correct range, select the range field on the screen. The controller will respond with a screen input keypad. Use this keypad to enter the correct range for the sensor that is connected, and press 'ENTER' to accept the value.

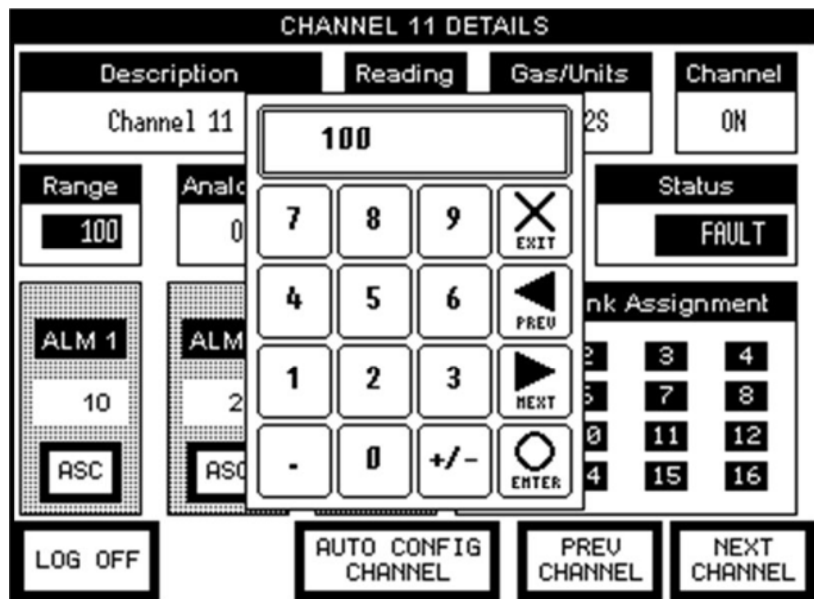

Figure 67 Change Range Entry

Analog Out

The Analog Out field is set to 'ON' or 'OFF'. Unless there is an AO-4 associated with this channel, this field should be left as 'OFF'. To turn on the Analog Out, select the Analog Out field on the screen, and the controller will change the status from 'OFF' to 'ON' or from 'ON' to 'OFF'.

Device Type

The Device Type field will display the type of device connected. If the Auto Configure did not find a valid device type, this field will display 'Model 700' as the default value. To change the device type, select the Device Type field and select the correct type of device. If the sensor is a Detcon Model 100, 600D, 600C or 700 series sensor connected via the Modbus™, select either '100', '600D', '600C' or '700', respectively. If the sensor is a CXT320 wireless sensor, select 'CXT320'. If the sensor is connected to a DA-4 module, select 'DA-4', if the sensor or device is connected to a DI-4 module, select 'DI-4'. If the sensor is connected to an RXT320 analog input, select 'RXT Analog'. If the sensor is connected to a CX Site Sentinel, select 'CX Sentinel'.

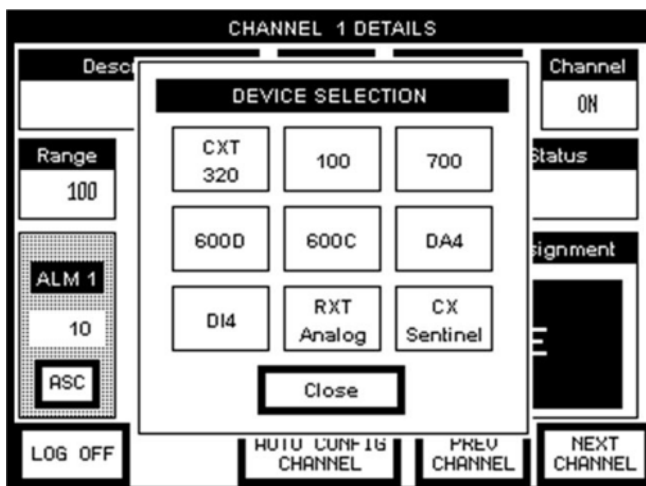

Figure 68 Device Type Selection

NOTE: If the Channel is set to ON, the controller will automatically attempt to communicate with the device connected. If communication is not established, the controller will take the channel into a "COMM ERR" (communication error) condition.

Status

The Status is read from the sensor or I/O Module, and cannot be changed.

Alarm Settings

All sensors have three alarm settings. These are labeled 'ALM1', 'ALM2', and 'ALM3' for Alarm 1, Alarm 2, and Alarm 3 respectively. The alarm relays can be configured for ascending or descending mode. In ascending mode the relay will be activated when the concentration is *above* the alarm threshold. The alarm relays can also be activated in descending mode. In this mode, the alarm relays will activate when the concentration is *below* the alarm threshold.

Typically these alarm set points are pre-determined by the user, and set for each sensor. Upon initialization of a channel these set points are set to the default value for the type of sensor that is connected, and set as 'ascending'. For sensors that are connected via a DA-4/ DI-4 module or RXT analog input, these set points are default values selected by the controller. These set point values should be checked, and changed if they are not correct. Likewise, the alarm should be checked to see if the alarm ascending/descending setting is correct. Typically alarms are ascending, with the exception of oxygen sensors. To set the values in the alarm fields,

select the appropriate field for the alarm. If selecting the alarm set-point, the display will prompt for a numeric input. The Ascending/Descending will change from 'ASC' to 'DEC' or from 'DEC' to 'ASC' when selected.

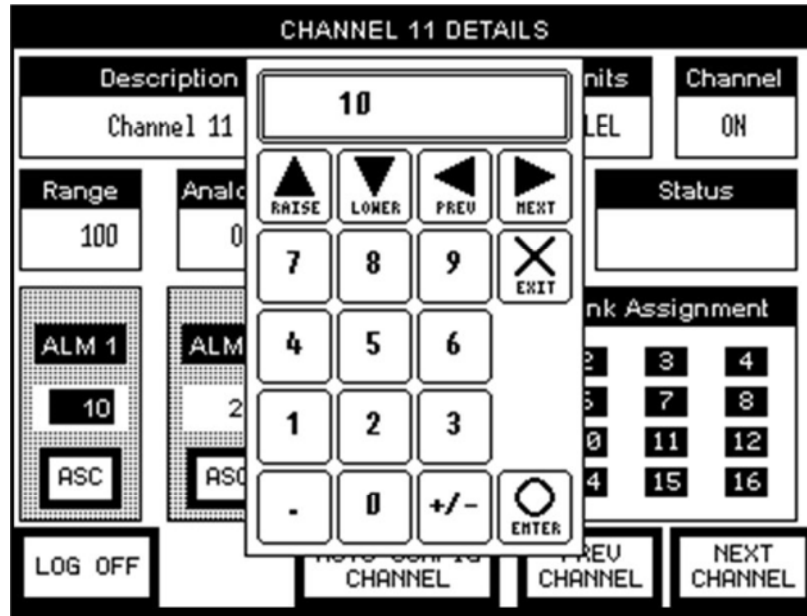

Figure 69 Alarm Level Set

There are sixteen banks of alarms that the sensor can be assigned to. The Relay Bank Assignment is used to select which bank the sensor is assigned. Selecting the bank (or banks) that the sensor is to be assigned to, will cause the bank selected to be highlighted in the display. The user must be logged in order to make bank selections.

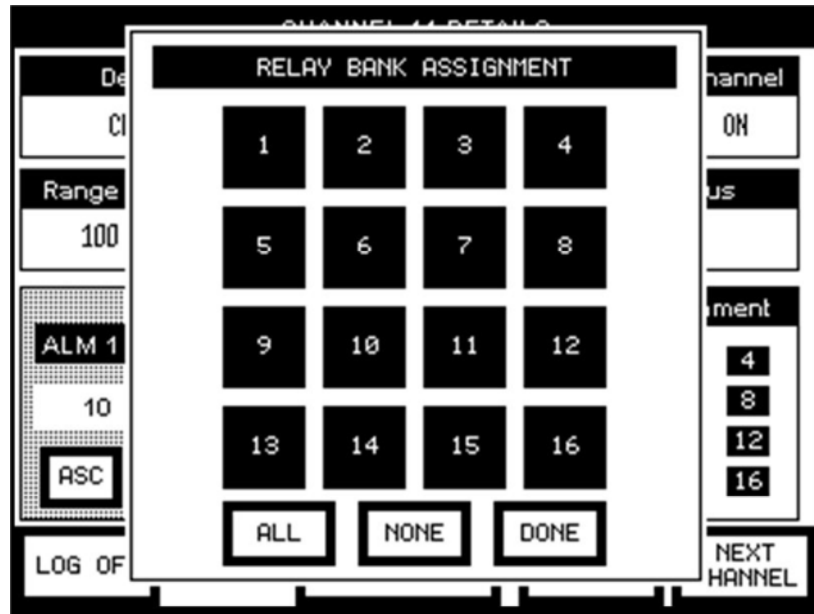

Figure 70 Alarm Bank 2 Select

6.2 Wireless Transceiver Channel Setup

When a wireless transceiver is being added to the controller, information for that transceiver will need to be added or modified on the WT Details screen. The Wireless Transceiver Details screen is used to view or change information directly related to a wireless transceiver. The Wireless Transceiver Details screen displays the transceiver’s description, its current status, if the channel is on or off, the voltage of the transceiver, the battery life remaining, the transceiver type and the RF link quality. Only the description can be changed on this screen. All other fields are read only.

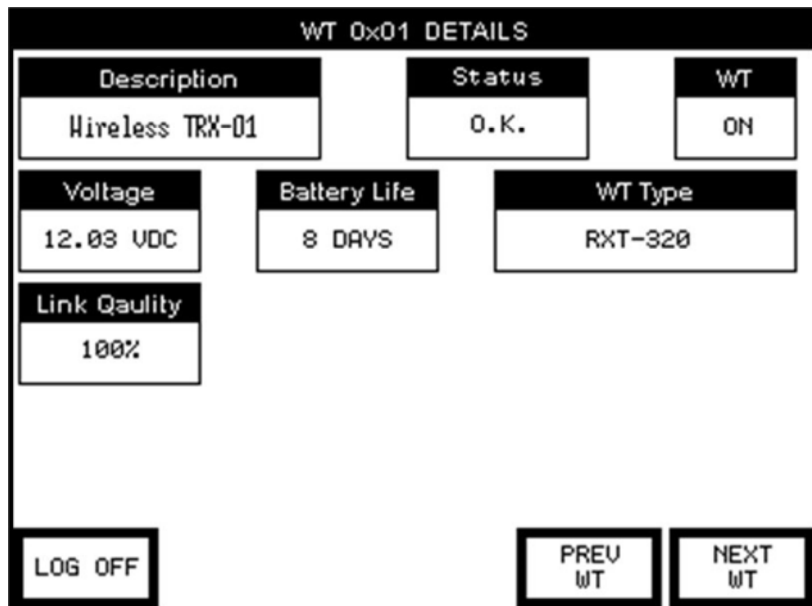

Figure 71 Wireless Transceiver Details Screen

If a transceiver channel is off, this screen will display the transceiver being annotated as ‘OFF’.

A transceiver can be added to the controller’s configuration in one of two ways:

1. An Auto Configure can be initiated from the Channel Details screen for the channel corresponding to the Modbus address of the wireless transceiver. This will cause the controller to poll for a wireless transceiver addressed at that channel on the Modbus™. If a transceiver is located, the controller will populate the sensor portion of the transceiver on the Channel Details screen found in the ‘SNS’ tab with the information obtained from the transceiver. For the transceiver portion, the controller will turn the corresponding transceiver ON in the ‘WT’ tab and populate the transceiver information on the WT Details screen.
2. The wireless transceiver can be manually turned on from the TURN ON/OFF WTS menu. See Section 5.4.7. Its corresponding sensor channel can also be turned on manually from the TURN ON/OFF CHANNELS menu.

After a transceiver is added, the information on the WT Details screen will need to be checked and/or updated to insure that the configuration for that transceiver is correct and accurate.

Description

On the WT Details screen, select the ‘Description’ field to modify the contents of that field. This will open an on-screen keyboard, which is used to enter the alphanumeric information that will be used as the transceiver’s description.

Status

The Status is read from the transceiver and cannot be changed.

WT (ON/OFF)

The WT field is used to turn the transceiver 'ON' or 'OFF'. If the WT field is 'OFF', the controller will not attempt to communicate with the transceiver. This is useful if the transceiver is not working properly and needs to be removed from being polled. Note that the transceiver is not actually removed from the configuration, but is only disabled. Turning the transceiver back 'ON' will restore the configuration information that was previously stored.

Voltage

The Voltage is read from the transceiver and cannot be changed. This field will display the actual voltage for the transceiver.

Battery Life

The Battery Life is read from the transceiver and cannot be changed. Battery life is displayed for transceivers that use Detcon's Smart Battery Pack and will be shown as number of days remaining for most wireless devices. Only alarm stations will display the battery life remaining as a percentage value instead of number of days. If smart batteries are not used, this field will show 'NON-RCHR' for CXT type transceivers to indicate that non-rechargeable batteries are being used.

WT Type

The WT Type field will display the type of transceiver connected such as an RXT-320 or CXT-320. If the Auto Configure did not find a valid device type, this field will display 'RXT-320' as the default value. To change the device type, select the Device Type field from the Channel Details screen in the 'SNS' tab. The device type cannot be changed from the WT Details screen in the 'WT' tab.

NOTE: If the transceiver is set to ON, the controller will automatically attempt to communicate with the transceiver. If communication is not established, the controller will take the transceiver into a "COMM ERR" (communication error) condition.

Link Quality

The Link Quality is read from the transceiver and cannot be changed. The link quality value is a percentage representing the RF link quality between the MCX-32's wireless transceiver and the specific slave wireless transceiver configured to the controller.

7.0 Remote Display

The Remote Display option affords the ability to connect a remote monitoring station to the MCX-32 Controller System. The Remote Display contains the same touch screen display and interface PCA as the MCX-32, but it does not have the ability to communicate directly with any of the devices connected to the MCX-32 controller. The firmware in the Remote Display monitors the activity of the MCX-32 Controller, and displays that information in much the same format as the controller. Many of the screens are the same as that of the controller, some have been modified, and will vary from the controller’s screens. The Remote Display’s System Configuration Menu also differs from that on the MCX-32 Controller.

The remote display communicates with the MCX-32 Controller via the controller’s RS-485 ‘REMOTE’ Port. The MCX-32 acts as a slave device to the remote display. The remote polls the MCX-32 controller for information. The MCX-32 Controller responds with a set of registers that the Remote Display uses to obtain information from the controller. These registers are described in Section 10.2.

Additional remote displays can be added to the configuration by ‘daisy-chaining’ the remote displays. To ‘daisy-chain’ remote displays, connect the next remote display in the chain to the slave RS-485 port of the remote display before it in the chain. If a PLC or other Modbus™ master device is utilized, that does not provide the ability to ‘daisy-chain’ the information to a slave RS-485 port, that PLC or Modbus™ master should be at the end of the chain.

7.1 Installation

1. Securely mount the MCX-32 Remote Display enclosure.
2. Connect 100-120/220-240VACVAC input wiring to the terminals labeled “ACV (L1)”, “Neutral (L2)”, and “Ground” (Figure 72). The power supply is capable of handling AC inputs from 100-120/220-240VAC 50-60Hz without degradation.

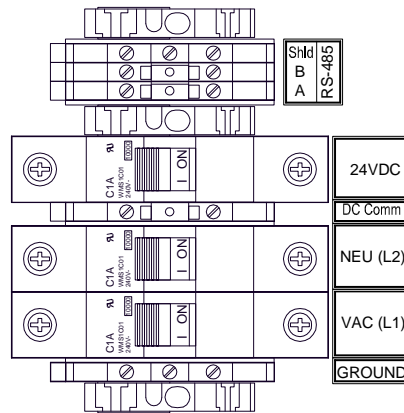

Figure 72 AC/DC Inputs

3. If applicable, connect auxiliary 24 VDC to the terminals labeled “24VDC” and “DC Comm”. This input can be used for primary power or back-up power in the event of AC power failure. The 24VDC input voltage (rated at 19.2-28.8VDC) should be capable of delivering at least 1Amp to the load (24Watt @ 24VDC). This voltage can come from an external 24VDC supply or a battery back-up. If batteries are directly connected to this input, the unit has the ability to provide the necessary battery charging voltage to the batteries. See Section 7.2.2.5 Power Management Screen for setting up the charging voltage for batteries.

4. A set of terminal blocks labeled “RS-485” is available for connection to the MCX-32 Controller. Connect the RS-485 cable from the MCX-32 Controller to these terminals.

7.2 Operation

The Remote Display operates like the MCX-32 controller, with some important differences. The Remote Display obtains most of the basic information from the controller, such as gas concentration, and alarm or fault conditions. The Remote Display does not have the ability to set or change any of the alarm or fault settings. Alarm and fault settings are set in the main controller, and the remote display can only display the status of these alarms.

Like the MCX-32 Controller, the main screen of the remote displays eight channels of information at a time. A group of ‘tabs’ are displayed near the top of the channel display area. Each of these tabs displays information for eight consecutive channels. Touching one of these tabs will cause the screen to display the eight channels associated with that tab. In normal operation, the screen will loop through each tab displaying all of the channels that are programmed into the controller. Each display of eight channels will remain on screen for approximately ten seconds, and will then move to the next eight channels. If there are any alarms active, the screen will remain on the display with the channel that is in alarm. If more than one channel is in alarm and the channels are in different tabs, the screen will alternate between the tabs with active alarms. Channel information is displayed in rows and each row provides the channel number, the channel description, the current sensor reading, the gas type, and any active alarms or faults. Selecting a channel on the screen will open the Channel Details Screen for that channel, and display all of that channel’s information.

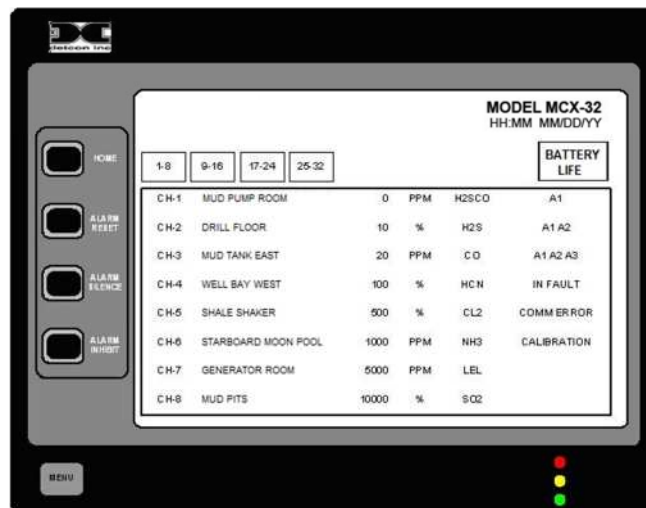

Figure 73 The MCX-32 Remote Main Display

Along the side of the display are a group of navigation and action buttons labeled: ‘HOME’, ‘ALARM RESET’, ‘ALARM SILENCE’, ‘ALARM INHIBIT’, and ‘MENU’. These buttons perform different tasks when pressed:

- HOME – Return to the Main Screen. This button will return the display to the Main Screen from any other screen.
- ALARM RESET – When latched alarms have occurred, will reset all latched alarm notifications.
- ALARM SILENCE – When a silenceable alarm is active, will silence or acknowledge all alarm notifications.
- ALARM INHIBIT – This function is not enabled on the Remote Display.
- MENU – Will display the System Configuration Screen. See Section 7.2.2 System Configuration Screen.

NOTE: Alarm Reset and Alarm Silence are configurable at the controller only and operation is determined by the settings in the RL4 Setup screen on the main MCX-32 controller. See Section 5.4.2.

7.2.1 Channel Details Screen

Detailed information for any sensor can be found on the Channel Details Screen. This screen does not allow the setting of alarm set-points or RL4 Banks. These settings are configured in the MCX-32 Controller. This screen can be viewed by selecting the channel from the Main Display. After selecting the appropriate channel, the Details Screen will be brought up on the display.

The Channel Details Screen is used to view or change information directly related to a sensor. The Channel Details Screen on the remote is different from the controller’s Channel Details Screen. The Remote Details Screen does not provide information on the alarm set points or the bank of alarms associated with the channel. The remote Channel Details Screen displays the sensors current concentration, the current sensor condition, the range of the sensor, the gas type, the sensor type, and if the channel is on or off. Some of these fields are changeable on this screen including the Channel Description (which is viewed on the Main Screen). The fields are: Channel Description, Range, Gas Type, and Sensor Type. The information on each channel details screen must match the information in the controller.

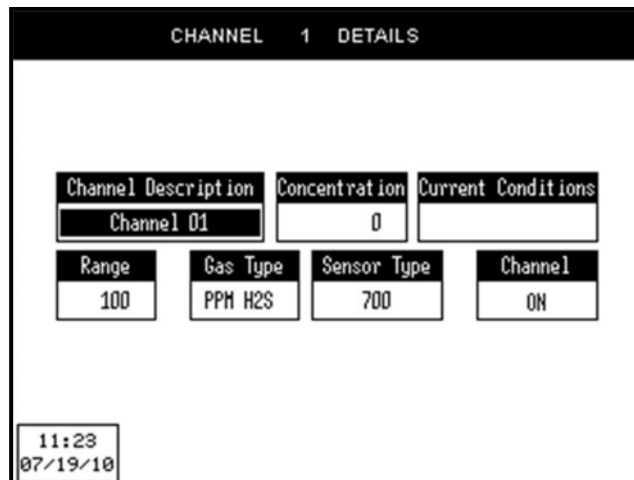

Figure 74 Remote Channel 1 Details Screen

7.2.2 System Configuration Screen

Pressing the ‘MENU’ button will take the operator to a screen with ‘Please Enter Password’ prompt. The controller incorporates password protection to keep un-authorized personnel from inadvertently changing the controller’s configuration. Selecting the prompt will display an on screen keyboard that the operator should use to enter the password.

NOTE: Changing the controller’s configuration should only be performed by authorized personnel. Improper settings in the controller’s configuration can cause the controller to operate incorrectly.

The default password is ‘abcd’ (lower case). The password can be changed from the System Configuration Screen. When the password has been entered the screen will change to the System Configuration Screen.

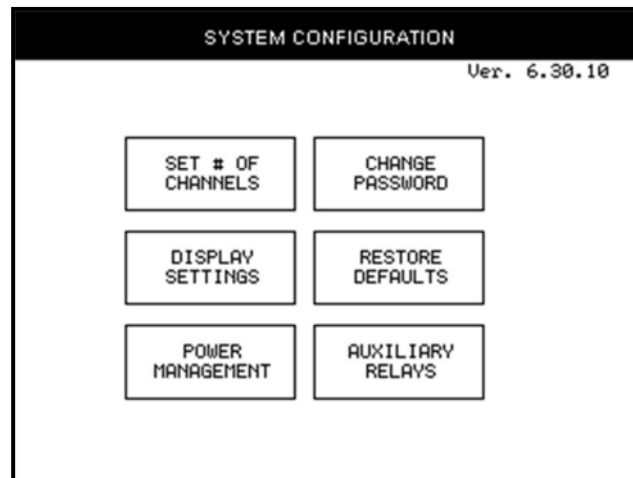

Figure 75 Remote Display System Configuration Screen

The System Configuration Screen provides access to six different aspects of the remote display that can be changed by the operator.

- ❖ SET # OF CHANNELS
- ❖ CHANGE PASSWORD
- ❖ DISPLAY SETTINGS
- ❖ RESTORE DEFAULTS
- ❖ POWER MANAGEMENT
- ❖ AUXILIARY RELAYS

7.2.2.1 Set # of Channels Screen

The Set # of Channels screen allows setting the maximum number of active channels that the controller will be able to communicate with. This number must match the number entered in the MCX-32 Controller.

7.2.2.2 Change Password

The Change Password screen allows the operator to change the password required to enter the System Configuration Menus. When selected, the operator is prompted to enter 'Current Password', 'New Password', and 'Retype New Password'. Passwords are case sensitive. After successfully inputting the current password, the operator may enter a new password, and then retype that new password. If the new password and the re-typed password are the same the new password will take effect, and will need to be used to enter the controllers System Configuration Screen.

7.2.2.3 Display Settings Screen

The Display Settings screen allows the adjustment of the screen brightness and contrast, the calibration of the screen touch panel, and the setting of the time and date.

7.2.2.4 Restore Defaults

When selected this button will restore default values to all of the channels, and restore the number of channels to 0. This will affect the channel description and other parameters pertaining to each channel. After selecting Restore Defaults, the number of channels must be set to the proper value, and each channel will need to be re-configured to reflect the proper information.

7.2.2.5 Power Management Screen

The Remote Display has the ability to monitor the voltage from the internal power supply, and an auxiliary 24VDC input voltage to the controller. The Power Management screen provides a digital display of the voltages applied. If an auxiliary 24VDC is not connected to the controller the voltage displayed will be correct for the primary, and the secondary will display 0.00. If an external power source is connected to the auxiliary 24VDC input, the secondary will display the applied voltage. The power management on the Remote Display operates just as the Power Management does on the MCX-32 controller. Refer to Section 5.4.5.6 Power Management Screen for setup operation of the Power Management.

7.2.2.6 Auxiliary Relays

The Auxiliary Relay screen allows the setup of the Remote Displays Fault and NO-Comm Relays. These relays operate via communication with the MCX-32 controller, but may be programmed to react differently from those in the MCX-32 controller. The screen is the same as the MCX-32 Auxiliary Relay Screen. Connection to these relays is obtained on the Interface PCA.

These relays may be setup as Energized or De-energized, Silence or Non Silence, and Latched or Unlatched. Refer to 5.4.8 for the setup of these relays.

7.3 Remote Setup

The setup of the Remote Display is critical for proper operation. The setup must match the setup in the MCX-32 Controller for proper operation. Two basic areas need to be configured:

- The number of sensors must be entered on the remote displays Set # of Channels screen. This number should match the total number of sensors connected to the MCX-32 controller.
- All of the Channel Details screens must be manually configured to match the controller and the sensors connected.

7.3.1 Sensor Channel Setup

When a sensor is being added to the controller, information for that sensor will need to be added or modified on the Channel Details screen on the remote display. The Channel Details screen is used to view or change information directly related to the sensor. The Channel Details screen displays the sensor's description, current concentration, the current sensor condition, the range of the sensor, the gas type, sensor type and if the channel is on or off. The Channel Details screen on the remote display will initially have default values for a channel that has been added to the controller. These fields must be changed to reflect the same information as those set in the controller. The fields are: Channel Description, Range, Gas Type, and Sensor Type. The information in these fields should match the channel details information obtained from the controller. The procedure for setting the information in these fields is the same as setting the information in the controller. Refer to Section 5.2.

If a channel is off, this screen will display as mostly blank with the gas type, and channel being annotated as 'OFF'.

8.0 Troubleshooting

If the MCX-32 display does not come on when power is applied to the unit, check the Power Supply Voltage for an output of 24VDC. Also check the Interface PCA, J5 PWR to GND for 24VDC out to the monitor.

The MCX-32 provides features to aid in troubleshooting communication problems in the sensor network. Problems with Modbus™ communications can be identified with the aid of the System Configuration's Modbus™ Utilities (Section 5.4.2). From this menu the status of each device can be viewed via the Modbus™ Diagnostic screen. The Modbus Diagnostics screen displays the status, number of errors, and the total error time of each channel or device connected on the Modbus™. This information can be used to determine if the communication problem is with one device, several devices, or the whole RS-485 Network.

NOTE: AO-4 and RL-4 modules are addressed at higher locations (80-8Fh for RL-4 modules, and A0-AFh for AO-4 modules) and appear when their respective menu buttons are selected. DA-4 and DI-4 modules, although addressed at higher locations (40-4Fh), are displayed at the corresponding addresses of their channels. (i.e. a DA-4 Module addressed at 42h will correspond to channels 9, 10, 11, and 12 respectively. Refer to Table 6 Input Device Modbus™ Addresses for Port 1 and Table 7 Input Device Modbus™ Addresses for Port 2).

If the controller is working properly, and only one or two devices are having communication problems, those devices should be suspect, and replaced with a known good devices for test purposes. If the problem clears, do not re-install the original devices until it can be determined that they are not the cause.

NOTE: When trouble shooting any device that may be on the RS-485 Modbus™ Network, always refer to that device's manual for proper setup of the device on the network, and refer to that manual's troubleshooting section for possible remedies for communication problems.

If the problem is the inability to communicate with 2 or more devices, the issue may be the RS-485 network. The first step in trouble shooting an RS-485 network is to look at the network wiring scheme. The MCX-32 controller utilizes two separate RS-485 ports for device communication. The wiring scheme for each port must adhere to RS-485 specifications (i.e. length of wire, proper termination, the use of repeaters, etc). It is critical that any device connected to the controller is connected to the appropriate port. Many communication problems can be caused by connecting the device to the wrong port. Refer to Section 6.0 Controller Setup for the port assignment of sensors and modules used by the controller.

Insure that the cabling used is the correct type for RS-485 communication. RS-485 wiring with power should consist of a two conductor, shielded twisted pair for RS-485 and two conductor power (General Cable Commodore p/n ZO16P0022189 is recommended). Check all cable connections for security, open, shorted, or improper wiring.

When it has been determined that the wiring scheme is correct and the cabling is correct, the next step in finding a communication problem is check communications between the MCX-32 and each individual sensor. On the MCX-32 controller, before troubleshooting an RS-485 problem it should be determined if the Communications error is on Port 1, Port 2, or both. This procedure will work for both Port 1 and Port 2 of the RS-485 Modbus™.

NOTE: The Controller utilizes 2 ports.

1. Disconnect the data wires (A & B) from the output terminal blocks of the effected port. This will remove all external devices from the controller.

2. If I/O Modules are installed in the controller, ensure that the appropriate RS-485 connector is plugged into the top module (TB1-J1 or TB2-J1), and the connector to the terminal blocks is plugged into the bottom module (TB1-J2, or TB2-J2).
 - a. Ensure that the Controller Setup is correct for the I/O Module(s) installed (Section 6.0).
 - b. Ensure that the address of the I/O Module(s) is set correctly.
 - c. Ensure that the System Configuration is set properly for communication with the I/O Module(s) (Section 5.0).
 - d. Check the Modbus™ Utilities to see if there is communication with the I/O Module(s).
 - e. The controller should be able to communicate with any I/O module correctly installed. If no communication can be established the Controller's Interface PCA is suspect and should be replaced.

NOTE: The male connector must be plugged into to the I/O Module at the top (right) of the din rail and the female connector must be plugged into the I/O Module at the bottom (left) of the stack of I/O modules. If these connectors are not properly installed, communication with other RS-485 devices will not be possible.

3. If no modules are installed, insure that the two RS-485 connectors are plugged into each other.

NOTE: If no I/O Modules are installed in the controller, the male connector must be plugged into female connector of each Modbus™ port for the RS-485 to communicate. If these connectors are not properly plugged into each other, communication with other RS-485 devices will not be possible.

4. Connect a working slave device directly to the output terminal blocks of the appropriate port. Make sure that it is functional and that the controller is able to communicate with the device. If it is not, the wiring to the terminal blocks, or the Controller's Interface PCA are suspect and should be checked or replaced.
5. If the controller is able to communicate with the device connected in Step 4, the controller may be considered as working. Remove the device connected in Step 4.
6. Check all of the wiring from the RS-485 terminal blocks to all of the devices connected to the controller.
7. Start with the first device outside the enclosure and moving away from the controller. One by one connect each device to the controller, noting if the controller can communicate with each device as it is connected.
 - a. Ensure that the Controller Setup is correct for the device installed (Section. 6.0).
 - b. Ensure that the address of the device is set correctly.
 - c. Ensure that the System Configuration is set properly for communication with the device (Section 5.0).
 - d. Check the Modbus™ Utilities to see if there is communication with the device.
 - e. The controller should be able to communicate with any device correctly installed. If no communication can be established the device or wiring should be suspect, and should be checked.
8. Replace any device that does not communicate properly with the controller.
9. If communication becomes intermittent or bad over a long distance, it may be necessary to install a Modbus repeater in the network. Contact Detcon Technical Support for assistance.

8.1 Wireless Troubleshooting

1. COMM ERR
 - a. Verify all devices on a specific port are set to the same RF Channel.
 - b. Verify controller address is set to F0. (Switches on term board, grounded I2C wire or jumper/battery board on black box transceiver.)
 - c. Verify all slave devices have a unique Modbus ID number.
 - d. Verify Network ID is the same as RF Channel.
 - e. Verify Modbus timeout values are set to recommended default values.
 - f. Verify Modbus baud rates are set to recommended default values.
 - g. Verify both device Modbus address and transceiver Modbus address are properly configured.
2. FAULT
 - a. Verify if sensor displays any fault. If so, follow sensor trouble shooting notes.
 - b. Verify if sensor cell needs replacement.
 - c. Verify Channel Details are correct.
3. LOW BATT
 - a. Replace batteries for applicable device.
4. Link Quality
 - a. Verify antenna is securely attached to all devices.
 - b. Verify obstructions are eliminated or minimized between slave device and controller or other slave devices.
5. Slow Gas Response
 - a. Normal if Sleep is turned on. To increase response time, turn sleep off, but the drawback will be reduced battery life for devices.
6. CXT or slave device not found during Auto Configure.
 - a. Verify device set to correct RF Channel.
 - b. Verify devices have correct Modbus address.
 - c. Verify Network ID is the same as RF Channel.
 - d. Verify device has valid MAC address.
 - e. For DA4 modules, RXT analog inputs and CX Site Sentinels, verify a proper mA load is present on input.
 - f. Any slave device near an elevated antenna needs to be at least as far from the antenna as the antenna is high. For example, if the antenna is 20ft. high, then the nearest slave device should be at least 20 ft. away.

9.0 Warranty and Customer Support

Detcon Headquarters

Shipping Address: 4055 Technology Forest Blvd., The Woodlands Texas 77381

Mailing Address: P.O. Box 8067, The Woodlands Texas 77387-8067

Phone: 888.367.4286, or 281.367.4100

Fax: 281.292.2860

- www.detcon.com
- service@detcon.com
- sales@detcon.com

All Technical Service and Repair activities should be handled by the Detcon Service Department via phone, fax or email at contact information given above. RMA numbers should be obtained from the Detcon Service Department prior to equipment being returned. For on-line technical service, customers should have ready the model number, part number, and serial number of product(s) in question.

All Sales activities (including spare parts purchase) should be handled by the Detcon Sales Department via phone, fax or email at contact information given above.

Warranty Notice

Detcon Inc. warrants the MCX-32 Controller and the MCX-32 Remote Display to be free from defects in workmanship of material under normal use and service for one year from the date of shipment. Detcon Inc. will repair or replace without charge any such equipment found to be defective during the warranty period. Full determination of the nature of, and responsibility for, defective or damaged equipment will be made by Detcon Inc. personnel.

Defective or damaged equipment must be shipped to the Detcon Inc. factory or representative from which the original shipment was made. In all cases, this warranty is limited to the cost of the equipment supplied by Detcon Inc. The customer will assume all liability for the misuse of this equipment by its employees or other contracted personnel.

All warranties are contingent upon the proper use in the application for which the product was intended and does not cover products which have been modified or repaired without Detcon Inc. approval, or which have been subjected to neglect, accident, improper installation or application, or on which the original identification marks have been removed or altered.

Except for the express warranty stated above, Detcon Inc. disclaims all warranties with regard to the products sold. Including all implied warranties of merchantability and fitness and the express warranties stated herein are in lieu of all obligations or liabilities on the part of Detcon Inc. for damages including, but not limited to, consequential damages arising out of, or in connection with, the performance of the product.

10.0 Specifications

System Specifications

Capacity:	64 I/O Channels
Sensor Inputs:	Analog 4-20mA or RS-485 Modbus™ RTU
Outputs:	Analog 4-20mA, Form C Relay Contacts, or RS-485 Modbus™ RTU
Warranty:	One year
Accuracy/Repeatability:	Display: < 1% Full Scale DA-4: < 1% Full Scale AO-4: < 1% Full Scale

Environmental Specifications

Operating Temperature:	-10°C to +50°C
Storage Temperature:	-30°C to +85°C
Humidity:	30-90% RH, non-condensing
Altitude:	0-2000m

Electrical Specifications

Input Voltage:	100-120/220-240VAC, 50-60Hz 19.2-28.8VDC
Max AC Current Rating:	2.4A/1.3A (100-120/220-240VAC)
Max DC Current Rating:	5A
Power Consumption:	Total Power consumption is dependent on number of I/O modules, number of gas sensors, and the type of gas sensors. Total power of controller with I/O modules and gas sensors not to exceed 120 Watts (5A at 24VDC)
RFI/EMI Protection:	Complies with EN61326
Electrical Classification:	NEMA 1 (MCX-32-N1P), NEMA 4X (MCX-32-N4X)

Mechanical Specifications

Display:	5.8" Diagonal Graphic Backlit LCD with Touch Screen
Dimensions:	MCX-32-N1P – 10.5"W x 8"H x 13"D MCX-32-N4X – 14.25"W x 14.25"H x 8.2"D

Wireless Specifications

Frequency:	ISM 2.4GHz
Range:	Indoor/No Line of Sight – 1,000ft Outdoor RF Line of Sight (with directional antenna) – 1.5 Miles
Spread Spectrum:	Digital-Sequence Spread Spectrum (DSSS)
Modulation:	0-QPSK
Sensitivity:	-102dBm (1% PER)

10.1 Hexadecimal Table

Table 9 Hexadecimal Conversion Table

ID#	MSD	LSD	ID#	MSD	LSD	ID#	MSD	LSD	ID#	MSD	LSD	ID#	MSD	LSD	ID#	MSD	LSD
0	0	0	43	2	B	86	5	6	129	8	1	172	A	C	215	D	7
1	0	1	44	2	C	87	5	7	130	8	2	173	A	D	216	D	8
2	0	2	45	2	D	88	5	8	131	8	3	174	A	E	217	D	9
3	0	3	46	2	E	89	5	9	132	8	4	175	A	F	218	D	A
4	0	4	47	2	F	90	5	A	133	8	5	176	B	0	219	D	B
5	0	5	48	3	0	91	5	B	134	8	6	177	B	1	220	D	C
6	0	6	49	3	1	92	5	C	135	8	7	178	B	2	221	D	D
7	0	7	50	3	2	93	5	D	136	8	8	179	B	3	222	D	E
8	0	8	51	3	3	94	5	E	137	8	9	180	B	4	223	E	F
9	0	9	52	3	4	95	5	F	138	8	A	181	B	5	224	E	0
10	0	A	53	3	5	96	6	0	139	8	B	182	B	6	225	E	1
11	0	B	54	3	6	97	6	1	140	8	C	183	B	7	226	E	2
12	0	C	55	3	7	98	6	2	141	8	D	184	B	8	227	E	3
13	0	D	56	3	8	99	6	3	142	8	E	185	B	9	228	E	4
14	0	E	57	3	9	100	6	4	143	8	F	186	B	A	229	E	5
15	0	F	58	3	A	101	6	5	144	9	0	187	B	B	230	E	6
16	1	0	59	3	B	102	6	6	145	9	1	188	B	C	231	E	7
17	1	1	60	3	C	103	6	7	146	9	2	189	B	D	232	E	8
18	1	2	61	3	D	104	6	8	147	9	3	190	B	E	233	E	9
19	1	3	62	3	E	105	6	9	148	9	4	191	B	F	234	E	A
20	1	4	63	3	F	106	6	A	149	9	5	192	C	0	235	E	B
21	1	5	64	4	0	107	6	B	150	9	6	193	C	1	236	E	C
22	1	6	65	4	1	108	6	C	151	9	7	194	C	2	237	E	D
23	1	7	66	4	2	109	6	D	152	9	8	195	C	3	238	E	E
24	1	8	67	4	3	110	6	E	153	9	9	196	C	4	239	F	F
25	1	9	68	4	4	111	6	F	154	9	A	197	C	5	240	F	0
26	1	A	69	4	5	112	7	0	155	9	B	198	C	6	241	F	1
27	1	B	70	4	6	113	7	1	156	9	C	199	C	7	242	F	2
28	1	C	71	4	7	114	7	2	157	9	D	200	C	8	243	F	3
29	1	D	72	4	8	115	7	3	158	9	E	201	C	9	244	F	4
30	1	E	73	4	9	116	7	4	159	9	F	202	C	A	245	F	5
31	1	F	74	4	A	117	7	5	160	A	0	203	C	B	246	F	6
32	2	0	75	4	B	118	7	6	161	A	1	204	C	C	247	F	7
33	2	1	76	4	C	119	7	7	162	A	2	205	C	D	248	F	8
34	2	2	77	4	D	120	7	8	163	A	3	206	C	E	249	F	9
35	2	3	78	4	E	121	7	9	164	A	4	207	C	F	250	F	A
36	2	4	79	4	F	122	7	A	165	A	5	208	D	0	251	F	B
37	2	5	80	5	0	123	7	B	166	A	6	209	D	1	252	F	C
38	2	6	81	5	1	124	7	C	167	A	7	210	D	2	253	F	D
39	2	7	82	5	2	125	7	D	168	A	8	211	D	3	254	F	E
40	2	8	83	5	3	126	7	E	169	A	9	212	D	4	255	F	F
41	2	9	84	5	4	127	7	F	170	A	A	213	D	5			
42	2	A	85	5	5	128	8	0	171	A	B	214	D	6			

10.2 Remote Display RS-485 Register Map

The Characteristics of the Modbus slave port are; 9600 baud, 8 bits, no parity, 1 stop bit.

Table 10 Remote Display RS-485 Register Map

Modbus Register	MCX-32 Channel	Description	Modbus Register	MCX-32 Channel	Description	Modbus Register	MCX-32 Channel	Description
40000	1	Reading	40044	23	Reading	40088	45	Reading
40001		Status*	40045		Status*	40089		Status*
40002	2	Reading	40046	24	Reading	40090	46	Reading
40003		Status*	40047		Status*	40091		Status*
40004	3	Reading	40048	25	Reading	40092	47	Reading
40005		Status*	40049		Status*	40093		Status*
40006	4	Reading	40050	26	Reading	40094	48	Reading
40007		Status*	40051		Status*	40095		Status*
40008	5	Reading	40052	27	Reading	40096	49	Reading
40009		Status*	40053		Status*	40097		Status*
40010	6	Reading	40054	28	Reading	40098	50	Reading
40011		Status*	40055		Status*	40099		Status*
40012	7	Reading	40056	29	Reading	40100	51	Reading
40013		Status*	40057		Status*	40101		Status*
40014	8	Reading	40058	30	Reading	40102	52	Reading
40015		Status*	40059		Status*	40103		Status*
40016	9	Reading	40060	31	Reading	40104	53	Reading
40017		Status*	40061		Status*	40105		Status*
40018	10	Reading	40062	32	Reading	40106	54	Reading
40019		Status*	40063		Status*	40107		Status*
40020	11	Reading	40064	33	Reading	40108	55	Reading
40021		Status*	40065		Status*	40109		Status*
40022	12	Reading	40066	34	Reading	40110	56	Reading
40023		Status*	40067		Status*	40111		Status*
40024	13	Reading	40068	35	Reading	40112	57	Reading
40025		Status*	40069		Status*	40113		Status*
40026	14	Reading	40070	36	Reading	40114	58	Reading
40027		Status*	40071		Status*	40115		Status*
40028	15	Reading	40072	37	Reading	40116	59	Reading
40029		Status*	40073		Status*	40117		Status*
40030	16	Reading	40074	38	Reading	40118	60	Reading
40031		Status*	40075		Status*	40119		Status*
40032	17	Reading	40076	39	Reading	40120	61	Reading
40033		Status*	40077		Status*	40121		Status*
40034	18	Reading	40078	40	Reading	40122	62	Reading

Modbus Register	MCX-32 Channel	Description	Modbus Register	MCX-32 Channel	Description	Modbus Register	MCX-32 Channel	Description
40035		Status*	40079		Status*	40123		Status*
40036	19	Reading	40080	41	Reading	40124	63	Reading
40037		Status*	40081		Status*	40125		Status*
40038	20	Reading	40082	42	Reading	40126	64	Reading
40039		Status*	40083		Status*	40127		Status*
40040	21	Reading	40084	43	Reading	40128	---	Reset Switch **
40041		Status*	40085		Status*			
40042	22	Reading	40086	44	Reading			
40043		Status*	40087		Status*			

* STATUS REGISTERS (for channels)

Bit 0	Alarm 1	0 = No Alarm	1 = In alarm 1
Bit 1	Alarm 2	0 = No Alarm	1 = In alarm 2
Bit 2	Alarm 3	0 = No Alarm	1 = In alarm 3
Bit 3	Fault	0 = No Fault	1 = Sensor Fault
Bit 4	Cal	0 = Normal Operation	1 = In Cal
Bit 5	Comm Error	0 = Normal Operation	1 = Communication Error
Bit 6 & Bit 7	Decimal Point	00 = No Decimal Point (No Divisor)	10 = 2 Decimal Point (Divisor of 100)
		01 = 1 Decimal Point (Divisor of 10)	
Bit 8	Not Used		
Bit 9	Not Used		
Bit 10	Not Used		
Bit 11	Not Used		
Bit 12	Not Used		
Bit 13	Not Used		
Bit 14	Not Used		
Bit 15	Not Used		

** RESEST SWITCH (REGISTER 40129)

Bit 0	Request to Alarm Silence, write a value of 1 to bit 0 using Modbus Function 06
Bit 1	Request to Alarm Reset, write a value of 1 to bit 1 using Modbus Function 06
Bit 2	Not Used
Bit 3	Not Used
Bit 4	Not Used
Bit 5	Not Used
Bit 6	Not Used
Bit 7	Not Used

Bit 8	Not Used
Bit 9	Not Used
Bit 10	Not Used
Bit 11	Not Used
Bit 12	Not Used
Bit 13	Not Used
Bit 14	Not Used
Bit 15	Not Used

Notes:

- 1) Registers 40001~40128 are read only registers. Use Modbus™ Function Code 3 only
- 2) Register 40129 will accept Modbus™ Function 03 or 06 only
- 3) The decimal point specifies the divisor for reading registers. Example: Assuming the channel is 01 (40000-40001): 40000=150, 40001=0x0040 (divisor of 10). User should divide the value in register 40000 by 10 (150/10=15.0).

10.3 Spare Parts

Part Number	Spare Parts
360-DLP120-024	120Watt 24VDC Din-rail Mounted Power Supply
500-005175-000	MC Series Interface PCA
995-0G306M-100	Graphic LCD Display, Programmed (must be programmed at Detcon)
995-0G3RS0-000	RS-232 / RS-485 option card (installed in Main MCX-32 Display)
976-041400-000	DA-4 I/O Module
975-041402-000	DI-4 I/O Module
975-041400-000	RL-4 Relay Module
975-041401-000	AO-4 4-20mA Output Module
076-00132D-000	RXT-320 Transceiver (Din-Rail Mount)

10.4 Revision Log

Revision	Date	Changes made	Approval
0.0	07/20/10	Original Release.	LU
0.1	08/10/10	Corrections made for Remote Display Option	LU
0.2	10/21/10	Updates and modifications added via Final Review	LU
1.0	06/02/11	Updates and modifications added relating to wireless function. Integrated different manuals due to different enclosure types into one manual that covers all enclosure types for the MCX-32. Removed “View Log Screen” section 5.4.8 and corrected register map Table 6.	LU
1.1	06/06/11	Modified Section 5.4 to remove “View Log” references.	LU
2.0	11/28/11	Updates and modifications added relating to software upgrade version 11.11.11. Removed wireless function.	LU
2.1	12/01/11	Added data logging feature, sections 5.0 and 6.3.12.	LU
2.2	04/23/12	Added note in Section 11.2 about Modbus slave port	LU
2.3	02/15/13	Added appendix for MCX-32 IP Address Documentation	LU
3.0	04/22/13	Extensive updates for addition of wireless support	LU
3.1	01/28/14	Added changes required for CE approval	LU
3.2	05/16/14	Add information to interface with Site Sentinel CX and CXT’s	LU

11.0 Appendix

11.1 MCX-32 IP Address Documentation

The MCX-32 has been configured for remote management through a built in web server. The web server interfaces to TCP/IP local networks with a DHCP Server.

Requirements: DHCP Server on the local network

Recommendations: General working knowledge of TCP/IP networking protocol for IP networks and/or consultation with an IT representative or consultant.

When a MCX-32 is plugged into the Local Area Network (LAN) with a DHCP Server, it will automatically be assigned an IP address. From the Main Menu on the local display of the MCX-32, you will be able to view the assigned IP Address.

Example:

DHCP Assigned IP Address: 192.168.0.120

The assignment and determination of the IP Address of the MCX-32 after it is plugged into the LAN will be dependent on the configuration and equipment of the DHCP server. Consult with an IT representative or consultant to ensure there is no disruption of service on your network.

On most business networks, a DHCP Server handles assigning the IP addresses of the devices that connect to it internally. This may be a router, firewall or a network server locally on the network. IP addresses are assigned dynamically as needed, ensuring that every device on the network has a unique address and allowing for addresses to be recycled and reused as devices come and go from the network.

One way to ensure that your MCX-32 will always be assigned the same IP address from the DHCP server is to configure a *IP Reservation* on the DHCP Server. An IP address reservation allows the DHCP server to assign a static (fixed) address to a device on a TCP/IP network based upon the MAC address of the device. The exact process for configuring a *DHCP Reservation* will be dependent on the manufacture and firmware version of the equipment hosting the DHCP service that is onsite at each specific location, but they all generally follow the same concept.

LAN ACCESS:

The interface can be then be accessed via any web browser (i.e. Internet Explorer, Google Chrome, Mozilla Firefox, etc.) by typing in the IP Address of the MCX-32:

Example:

DHCP Assigned IP Address: 192.168.0.120

Web Interface Example: <http://192.168.0.120>

REMOTE ACCESS:

To access the MCX-32 from outside of the local network, a VPN will need to be configured or Port Forwarding to allow web traffic to flow to the device. The exact instructions for configuring a VPN or Port Forwarding will be completely dependent upon the network type, equipment and security requirements for each customer and site. Consultation with an IT representative or consultant is recommended to ensure that security and service is not compromised for other devices on the local network.

WHAT IS DHCP?

The **Dynamic Host Configuration Protocol (DHCP)** is a network protocol that is used to configure network devices so that they can communicate on an IP network. A DHCP client uses the DHCP protocol to acquire configuration information, such as an IP address, a default route and one or more DNS server addresses from a DHCP server. The DHCP client then uses this information to configure its host. Once the configuration process is complete, the host is able to communicate on the internet.

The DHCP server maintains a database of available IP addresses and configuration information. When it receives a request from a client, the DHCP server determines the network to which the DHCP client is connected, and then allocates an IP address or prefix that is appropriate for the client, and sends configuration information appropriate for that client.

DHCP servers typically grant IP addresses to clients only for a limited interval. DHCP clients are responsible for renewing their IP address before that interval has expired, and must stop using the address once the interval has expired, if they have not been able to renew it.

Shipping Address: 4055 Technology Forest Blvd., The Woodlands Texas 77381
Mailing Address: P.O. Box 8067, The Woodlands Texas 77387-8067

Phone: 888.367.4286, 281.367.4100 • Fax: 281.292.2860 • www.detcon.com • sales@detcon.com