

Digital Controller SC4500

Applications

- Wastewater
- Drinking water
- Industrial water
- Other



Ready for Now. Ready for the Future.

Technologies are advancing rapidly, providing new levels of convenience, accuracy, and efficiency. Which is exactly why the SC4500 Controller from Hach® is designed to integrate easily into your current system while allowing you to upgrade as your capabilities advance, without having to replace inventory. With a wide range of analog and digital connectivity options and the availability of intelligent instrument and data management features, the SC4500 unlocks the future, today.

Easy Adoption

The familiar experience of a modern touchscreen, the ability to use your current Hach sensors, and the same footprint as the SC200, make installation and integration of the SC4500 Controller seamless.

No Time for Downtime

The SC4500's built-in predictive diagnostic software ensures measurement confidence and reduces the risk of unexpected equipment downtime by enabling proactive maintenance planning via MSM, including step-by-step instructions.

The Connectivity Options You Need

The Controller provides local communication to SCADA or a PLC, as well as remote access through a secure, cloud-based connectivity option to integrate with Claros, the Water Intelligence System from Hach. From analog and advanced digital protocols to Wi-Fi, cellular or LAN, the SC4500 gives you the flexibility to adapt in a rapidly changing world.

Technical Data*

Description	Microprocessor-controlled and menu-driven controller that operates the sensor
Dimensions	½ DIN - 144 x 144 x 192 mm (5.7 x 5.7 x 7.6 in.)
Weight	1.7 kg (controller only, w/o modules)
Display	3.5-inch TFT colour display with capacitive touchpad
Enclosure waterproof rating	UL50E type 4X, IEC/EN 60529-IP 66, NEMA 250 type 4X Metal enclosure with a corrosion-resistant finish
Operating temperature range	-20 to 60 °C (-4 to 140 °F) (8 W (AC)/9 W (DC) sensor load) -20 to 45 °C (-4 to 113 °F) (28 W (AC)/20 W (DC) sensor load) Linear derating between 45 and 60 °C (-1.33 W/°C)
Storage conditions	-20 to 70 °C, 0 - 95% relative humidity, non-condensing
Altitude	2000 m maximum
Installation category	Category II
Pollution degree	4
Protection class	I, connected to protective earth
Power requirements	AC controller: 100-240 VAC ±10%, 50/60 Hz; 1 A (28 W sensor load) DC controller: 24 VDC +15% -20%; 2.5 A (20 W sensor load)
Measurements	Two device digital SC connectors
Relays	Two relays (SPDT); Wire gauge: 0.75 to 1.5 mm ² (18 to 16 AWG) AC controller Maximum switching voltage: 100 - 240 VAC Maximum switching current: 5 A Resistive/1 A Pilot Duty Maximum switching power: 1200 VA Resistive/360 VA Pilot Duty DC controller Maximum switching voltage: 30 VAC or 42 VDC Maximum switching current: 4 A Resistive/1 A Pilot Duty Maximum switching power: 125 W Resistive/28 W Pilot Duty
Communication (optional)	Analog: Five 0-20 mA or 4-20 mA analog outputs on each analog output module Up to two analog Input modules (0-20 mA or 4-20 mA). Each input module replaces a digital sensor input. Digital: Profibus DPV1 module Modbus TCP Profinet IO module Ethernet IP module
Network connectivity	LAN: Two Ethernet connectors (10/100 Mbps) Cellular: External 4G Wi-Fi
USB Port	Used for data download and software upload. The controller records approximately 20,000 data points for each connected sensor.
Compliance certifications	CE, ETL certified to UL and CSA safety standards (with all sensor types), FCC, ISED, KC, RCM, EAC, UKCA, SABS, C (Morocco)
Warranty	24 months
Compatible network technologies	GSM 3G/4G (e.g. AT&T, T-Mobile, Rogers, Vodafone etc.) CDMA (e.g. Verizon)

*Subject to change without notice.

Compatible Instruments / Software Version (Release Year)

Amtax sc / V2.30 (2018) or higher
 A-ISE sc / V1.02 or higher
 AN-ISE sc / V1.08 (2013) or higher
 N-ISE sc / V1.02 or higher
 Nitratax clear sc, Nitratax eco sc,
 Nitratax plus sc / V3.13 (2013) or higher
 Phosphax sc / V2.30 (2018) or higher
 Phosphax sc LR/MR/HR / V1.01 (2018)
 or higher
 TSS sc / V41.73 (2013) or higher
 Solitax sc / V2.20 (2013) or higher

TU5300sc, TU5400sc / V1.34 (2017)
 or higher
 SS7 sc (in Bypass) / V1.06 (2006) or higher
 Ultraturb sc / V3.06 (2017) or higher
 1720E / V2.10 (2006) or higher
 Sonatax sc / V1.15 (2016) or higher
 CL17sc / V2.7 (2019) or higher
 CL10sc / V1.14 (2013) or higher
 9184sc, 9185sc, 9187sc* / V2.03 (2013)
 or higher
 Uvas plus sc / V3.01 (2017) or higher
 LDO 2 sc* / V1.22 (2013) or higher

3798sc* / V2.03 (2013) or higher
 3700sc + Inductive Conductive Digital
 Gateway 6120800 / V3.00 (2017) or higher
 3422sc, Analog 3400 + Contacting Cond.
 Digital Gateway 6120700 / V3.00 or higher
 pHD sc*, pHD-S sc / V3.10 (2016) or higher
 1200-S sc* / V2.04 (2013) or higher
 pHD analog + Digital Gateway 6120500 /
 V3.00 (2017) or higher
 RC and PC analog sensor + Digital Gateway
 for conventional analog pH and ORP
 sensors 6120600 / V3.00 (2017) or higher
 8362sc* / V3.00 (2017) or higher

**Hardware Version1 of instrument is not supported*

Dimensions

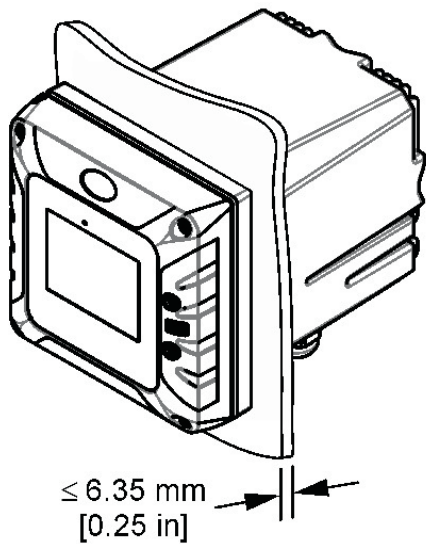

Panel mounting dimensions

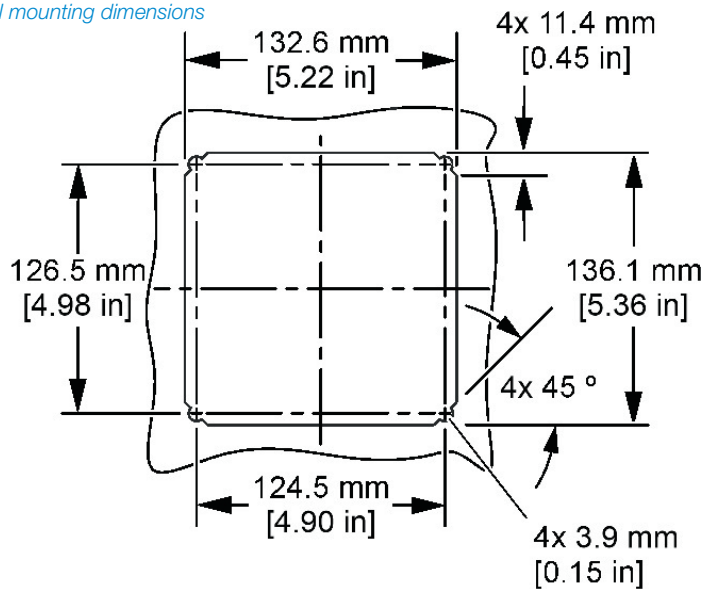

Top and bottom views

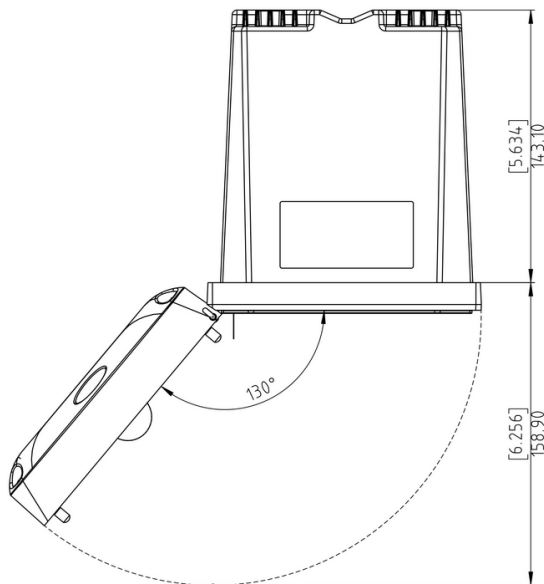

Door Opening Details

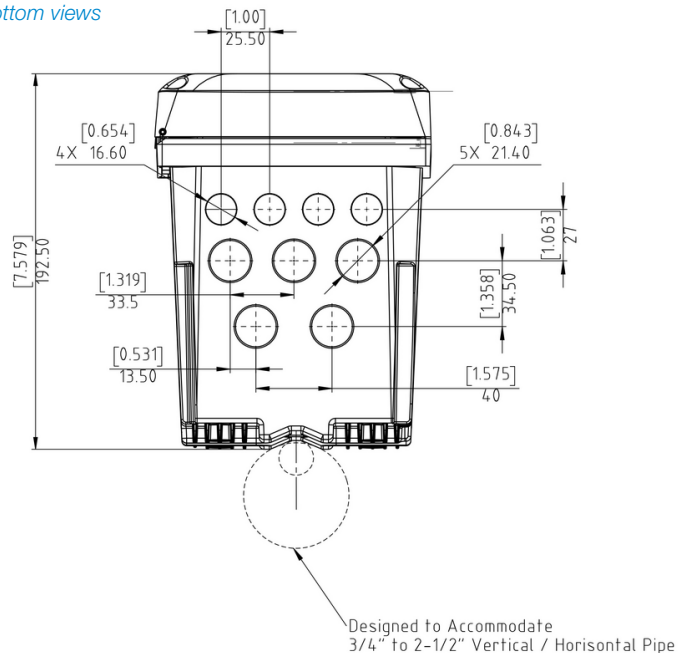

Order Information

Controller

LXV525.99A11551	SC4500 Controller, Prognosys, 5x mA Output, 2 digital Sensors, without plug
LXV525.99C11551	SC4500 Controller, Prognosys, 5x mA Output, 2 digital Sensors, EU plug
LXV525.99A11541	SC4500 Controller, Prognosys, 5x mA Output, 1 digital Sensor, 1 mA Input, without plug
LXV525.99C11541	SC4500 Controller, Prognosys, 5x mA Output, 1 digital Sensor, 1 mA Input, EU plug
LXV525.99AA1551	SC4500 Controller, Claros-enabled, 5x mA Output, 2 digital Sensors, without plug
LXV525.99CA1551	SC4500 Controller, Claros-enabled, 5x mA Output, 2 digital Sensors, EU plug
LXV525.99AA1541	SC4500 Controller, Claros-enabled, 5x mA Output, 1 digital Sensor, 1 mA Input, without plug
LXV525.99C11541	SC4500 Controller, Prognosys, 5x mA Output, 1 digital Sensor, 1 mA Input, EU plug

Additional configurations are available. Please contact Hach Technical Support or your Hach representative.

Accessories

LXZ525.99.D0001	SC4500 mA Input Module
LXZ525.99.D0002	SC4x00 mA Output Module (5 Outputs)
LXZ525.99.C0002	SC4500 Ethernet IP Upgrade Kit
LXZ525.99.C0003	SC4500 Modbus TCP/IP Upgrade Kit
LXZ525.99.00026	SC4500 Ethernet Cable M12 to M12 / C1D2, 10 m
LXZ525.99.00017	SC4500 USB Stick
LXZ524.99.00004	SC4x00 UV Protection Screen
LXZ524.99.00005	SC4x00 UV Protection Screen with Sunroof
LXZ524.99.00033	SC4x00 Sunroof Visor
LXZ524.99.00036	SC4x00 Mounting Hardware Sunroof with Visor
LXZ524.99.00037	SC4x00 Sunroof with Visor



This instrument connects to Claros, Hach's innovative Water Intelligence System. Claros allows you to seamlessly connect and manage instruments, data, and process – anywhere, anytime. The result is greater confidence in your data and improved efficiencies in your operations. To unlock the full potential of Claros, insist on Claros Enabled instruments.



With Hach Service, you have a global partner who understands your needs and cares about delivering timely, high-quality service you can trust. Our Service Team brings unique expertise to help you maximise instrument uptime, ensure data integrity, maintain operational stability, and reduce compliance risk.