

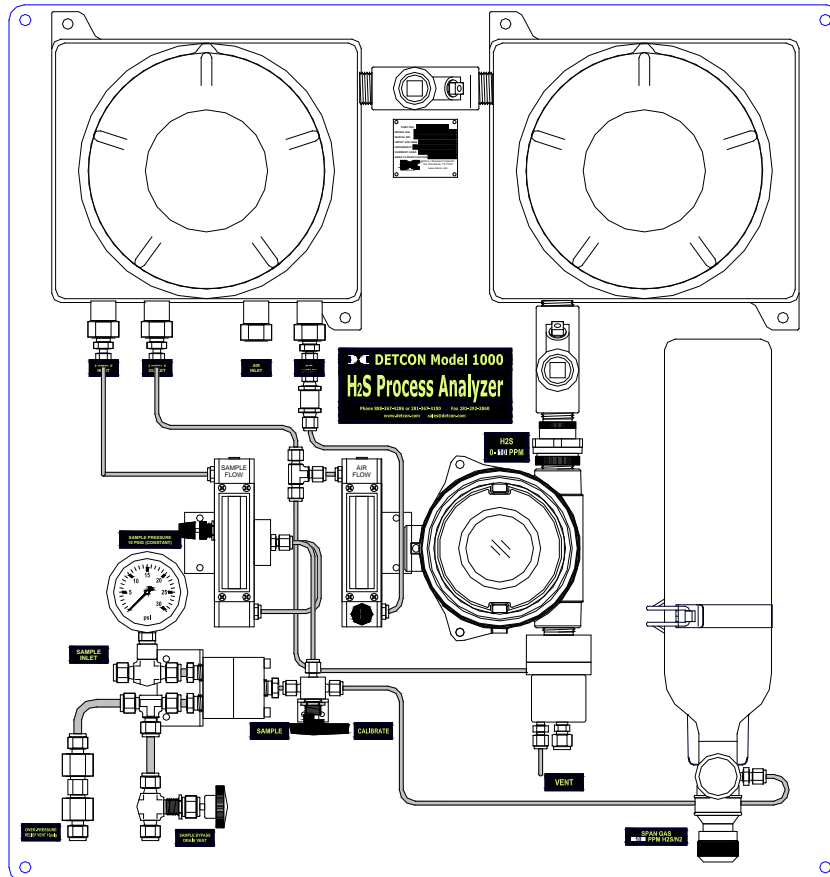

# Detcon Model 1000

H<sub>2</sub>S Process Analyzer - Electrochemical Sensor



## Operator's Installation and Instruction Manual

Detcon Model 1000 Series H<sub>2</sub>S Analyzer consists of two major assemblies:

1. The Model 1000 Series gas sample-conditioning assembly.
2. The Model DM-624 H<sub>2</sub>S gas sensor (using Alcohol Free - Electrochemical Sensor or Hi-Range Electrochemical Sensor)

◆ DETCON, Inc.  
4055 Technology Forest Blvd.,  
The Woodlands, Texas 77381  
Ph.281.367.4100 / Fax 281.298.2868  
[www.detcon.com](http://www.detcon.com)

This page left intentionally blank

# Table of Contents

<b>1.</b>	<b>Introduction.....</b>	<b>1</b>
1.1	DM-624 Sensor .....	1
1.2	Electrochemical Sensor .....	2
1.3	Microprocessor Control Circuit.....	2
1.4	Base Connector Board.....	3
1.5	Interference Data .....	4
1.6	Enclosures .....	4
<b>2.</b>	<b>Specifications.....</b>	<b>5</b>
<b>3.</b>	<b>Installation.....</b>	<b>6</b>
3.1	Mounting .....	6
3.2	Gas Connections and Sampling System Notes.....	6
3.3	Electrical Connections.....	9
3.4	Relays and RS-485 Setup .....	10
<b>4.</b>	<b>Start Up.....</b>	<b>12</b>
<b>5.</b>	<b>Operating Software .....</b>	<b>13</b>
5.1	Programming Magnet Operating Instructions .....	13
5.2	Operating Software.....	13
5.2.1	<i>Normal Operation</i> .....	13
5.2.2	<i>Calibration Mode</i> .....	14
5.2.3	<i>Program Mode</i> .....	14
5.2.4	<i>Software Flow Chart</i> .....	16
<b>6.</b>	<b>Calibration and Maintenance .....</b>	<b>16</b>
6.1.1	<i>Zero Calibration</i> .....	17
6.1.2	<i>Span Calibration</i> .....	17
<b>7.</b>	<b>Programming Alarms.....</b>	<b>19</b>
7.1	Alarm Reset.....	19
7.2	Other Alarm Functions .....	19
<b>8.</b>	<b>Programming Features.....</b>	<b>19</b>
<b>9.</b>	<b>RS-485 Protocol .....</b>	<b>20</b>
<b>10.</b>	<b>Display Contrast Adjustment .....</b>	<b>22</b>
<b>11.</b>	<b>Low Flow Fault Options.....</b>	<b>22</b>
<b>12.</b>	<b>Sensor Replacement.....</b>	<b>23</b>
<b>13.</b>	<b>Troubleshooting .....</b>	<b>23</b>
<b>14.</b>	<b>Spare Parts .....</b>	<b>24</b>
<b>15.</b>	<b>Warranty .....</b>	<b>26</b>
<b>16.</b>	<b>Flow Diagrams .....</b>	<b>27</b>
<b>17.</b>	<b>Wiring Diagram .....</b>	<b>29</b>
<b>Appendix C</b>	<b>.....</b>	<b>30</b>
	Revision Log .....	30

## Table of Figures

Figure 1 DM-624 Sensor.....	1
Figure 2 Construction of Electrochemical Sensor.....	2
Figure 3 Functional Block Diagram.....	3
Figure 4 DM-624 Control Circuit.....	3
Figure 5 Connector Board Terminals.....	3
Figure 6 Enclosures.....	4
Figure 7 Unit Dimensions.....	6
Figure 8 Port Identification.....	7
Figure 9 Optional Bubbler Bottle.....	8
Figure 10 Installation Wiring Connections.....	9
Figure 11 Alarm Jumpers.....	10
Figure 12 RS-485 Dip Switches.....	11
Figure 13 Programming Magnet.....	13
Figure 14 DM-624 Software Flow Chart.....	16
Figure 15 Analyzer Parts Identification.....	24
Figure 16 DM-624 Replacement Parts.....	25
Figure 17 Unit Flow Diagram.....	27
Figure 18 Pump Box Flow Diagram.....	28
Figure 19 Wiring Diagram.....	29

## List of Tables

Table 1 Hexadecimal Conversion.....	11
Table 2 Sample Flow Rate.....	12
Table 3 Sample Flow Rate.....	17

# 1. Introduction

The Detcon Model 1000 Series H<sub>2</sub>S Process Analyzer is a 110/220VAC or 24VDC powered analyzer that provides a select gas sample mixture to an on-board DM-624 H<sub>2</sub>S gas sensor assembly. The range of gas analysis can span from 0-10ppm up to 0-5% (see Table 2 **Sample Flow Rate**). The range of analysis is determined at time of order.

When located outdoors, the H<sub>2</sub>S Process Analyzer package should be appropriately covered from direct weather exposure. The Model 1000 Series H<sub>2</sub>S Process Analyzer can optionally be ordered with a full NEMA 4 enclosure.

The “Power Supply” enclosure on the upper right side of the unit houses a 24VDC power supply, a 24V DC-DC Converter, and a terminal PCB labeled for all input and output field wiring. The “Pump/Flow” enclosure located on the upper left houses an air dilution pump, an activated carbon scrubber, and optional air flow fault and sample flow fault alarm PCB’s.

The analyzer requires a constant, liquid-free, 10±2psig sample pressure, which is provided by the customer or may be supplied by Detcon as a separate gas sample handling system.

The on-board gas sample conditioning system includes a stainless steel pressure gauge (0-30psig), and a Genie membrane filter to provide the analyzer with absolute condensate liquid protection. On the bypass port of the Genie membrane filter, a 15 psig over-pressure relief valve and flow control valve are also provided. The flow control valve can be used as a continuous sample bypass and liquid exhaust vent. A dedicated air and sample mixture is maintained via 2 control valves and 2 rotameters. The Sample is then delivered to the Model DM-624 H<sub>2</sub>S gas sensor for analysis. An optional on-board span gas cylinder is provided for span calibration, and a selectable 3-way valve is provided for manually switching between sample monitoring and span calibrations. An optional Acetic Acid Bubbler apparatus is available to scrub the gas sample when it contains high concentrations of VOC’s as found in some injection spray H<sub>2</sub>S scavenger chemistries. An optional live heat tracing feature may be used to prevent condensation after the Genie Membrane Filter.

## 1.1 DM-624 Sensor



Figure 1 DM-624 Sensor

Detcon MicroSafe™ Model DM-624, toxic sensors are non-intrusive “Smart” sensors designed to detect and monitor for H<sub>2</sub>S gas in the ppm range. A primary feature of the sensor is its method of automatic calibration, which guides the user through each step via instructions displayed on the backlit LCD. The sensor features field adjustable, fully programmable alarms and provides relays for two alarms plus fault as standard. The sensor comes with two different outputs: analog 4-20mA, and serial RS-485. These outputs allow for greater flexibility in system integration and installation. The microprocessor-supervised electronics are packaged as a plug-in module that mates to a standard connector board. Both are housed in a conduit that includes a glass lens window that allows for the display of sensor readings as well as access to the sensor’s menu driven features via a hand-held programming magnet.

## 1.2 Electrochemical Sensor

The sensor is an electrochemical cell. Each cell consists of three electrodes embedded in an electrolyte solution all housed beneath a diffusion membrane. Sensitivity to specific target gases is achieved by varying composition of any combination of the sensor components. Good specificity is achieved in each sensor type. The cell is diffusion limited via small capillary barriers resulting in long service life of up to 3 or more years depending on the application.

---

**NOTE:** This particular sensor cell is unique in that it has no cross-sensitivity to alcohol vapors and thus is a good choice for measuring H<sub>2</sub>S in natural gas pipelines.

---

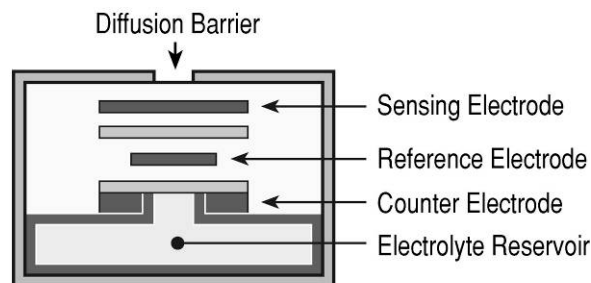

**Figure 2** Construction of Electrochemical Sensor

### DM-624 Electrochemical Sensor Principle of Operation

Method of detection is by an electrochemical reaction at the surface of an electrode called the sensing electrode. Air and gas diffuse through the stainless steel filter and the capillary diffusion barrier. The controlling circuit maintains a small external operating voltage between the sensing and counter electrodes of the proper bias and magnitude so that no current flows to or from the reference electrode while its potential is maintained at the correct fixed voltage — usually ground. The electrochemical reaction creates a change in current flow from the counter electrode to the sensing electrode. This change in current is proportional to the gas concentration and is reversible. The quick response of the sensor results in continuous monitoring of sample gas conditions.

## 1.3 Microprocessor Control Circuit

The control circuit is microprocessor based, and is packaged as a plug-in field replaceable module, facilitating easy replacement and minimum down time. Circuit functions include a basic sensor pre-amplifier, on-board power supplies, microprocessor, back lit alpha numeric display, alarm status LED indicators, magnetic programming switches, an RS-485 communication port, and a linear 4-20mA DC output.

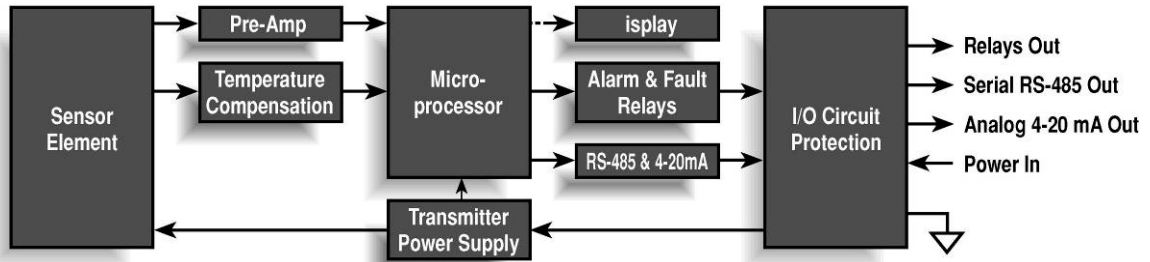

Figure 3 Functional Block Diagram

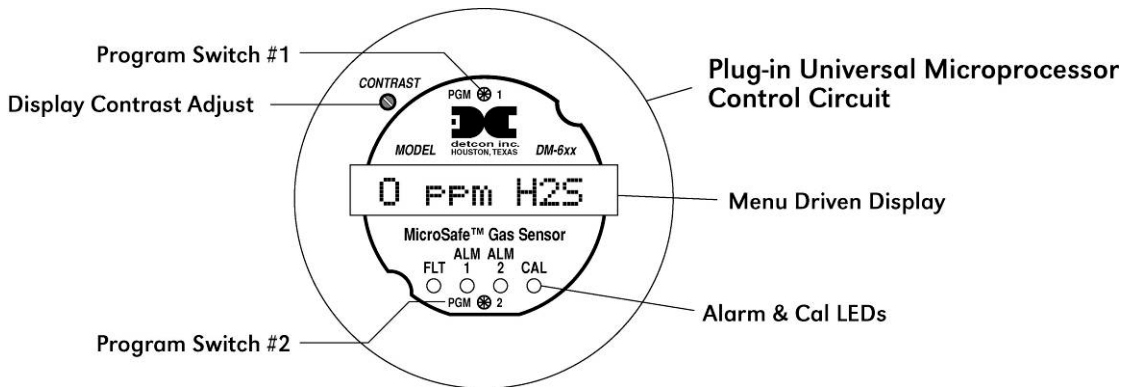

Figure 4 DM-624 Control Circuit

## 1.4 Base Connector Board

The base connector board is mounted in the enclosure and includes: the mating connector for the control circuit, reverse input and secondary transient suppression, input filter, alarm relays, lugless terminals for all field wiring, and a terminal strip for storing unused programming jumper tabs. The alarm relays are contact rated 5 amps @ 250VAC, 5 amps @ 30VDC and coil rated at 24VDC. Gold plated program jumpers are used to select either the normally open or normally closed relay contacts.

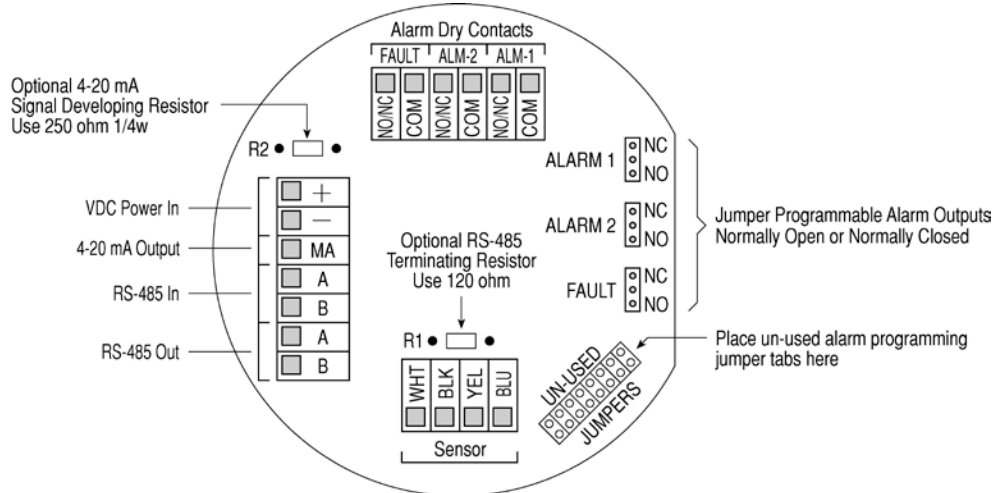

Figure 5 Connector Board Terminals

## 1.5 Interference Data

DM-624 series electrochemical H<sub>2</sub>S sensors are subject to interference from other gases. This interaction is shown in the following table as the relation between the amount of the interfering gas applied to the sensor, and the corresponding reading that will occur (in ppm).

Gas	Interference
Carbon monoxide	300ppm ≤ 1.5ppm
Chlorine	1ppm = -0.2ppm
Ethyl mercaptan	3ppm = 1ppm
Ethylene	100ppm = 0
Hydrogen	1% = < 5ppm
Hydrogen chloride	5ppm = 0
Hydrogen cyanide	10ppm = 0
Nitric oxide	35ppm < 2ppm
Nitrogen dioxide	5ppm = -0.5ppm
Sulfur dioxide	5ppm < 1ppm
Methyl mercaptan	2ppm = 1ppm

## 1.6 Enclosures

The sensor is packaged in a cast metal enclosure. The enclosure is fitted with a threaded cover that has a glass lens window. Magnetic program switches located behind the transmitter module faceplate are activated through the lens window via a hand-held magnetic programming tool allowing non-intrusive operator interface with the sensor. All calibration and alarm level adjustments can be accomplished without removing the cover.

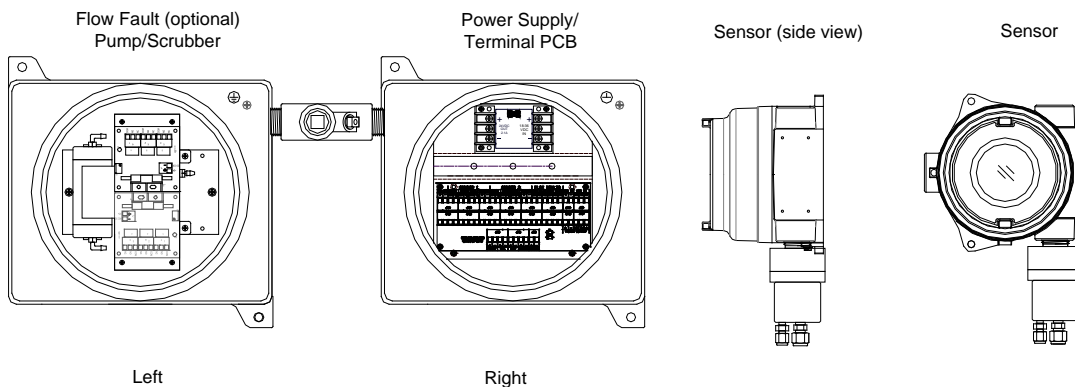

**Figure 6** Enclosures

A 24VDC power supply and termination PCB for the power, relay contacts, 4-20mA output, and/or RS485 signal are located in the upper right enclosure. The pump and optional low flow fault assemblies are located in the upper left enclosure.



## 2. Specifications

### Sensor Type

Electrochemical cell

### Measurement Range

0-10ppm H<sub>2</sub>S, up to 0-5 % H<sub>2</sub>S

### Accuracy/Repeatability

±10% of reading or ±0.5ppm, whichever is greater

### Response/Clearing Time

T80 < 1 minute

### Operating Temperature

-40°F to +122°F: -40°C to +50°C

### Outputs

Linear 4-20mA DC; RS-485 Modbus™; 3 relays (alarm 1, alarm 2, and fault), Contacts rated 5 amps

### Input Voltage

110~220VAC; 18~36VDC

### Power Consumption

700mA (16.8 watts)

### Electrical Classification

Non Hazardous Area

### Sensor Life/Warranty

Sensor: 6 month conditional warranty; Transmitter: 2 year warranty

### Analyzer Weight

70 lbs.

### Dimensions

29" X 29" X 8"

### 3. Installation

#### 3.1 Mounting

Securely mount the Model 1000 analyzer panel or NEMA 4 enclosure (optional) in accordance with Figure 7.

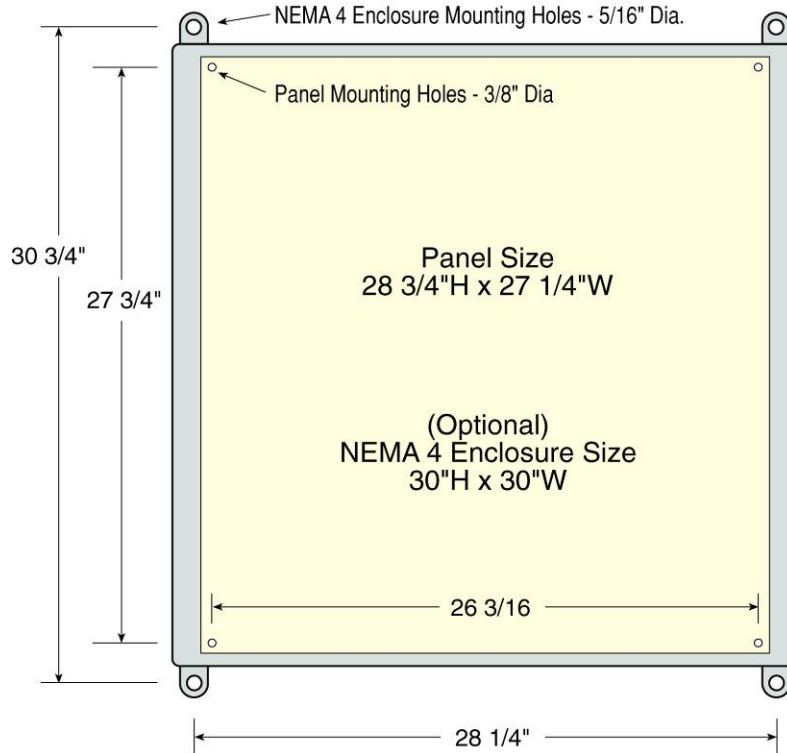
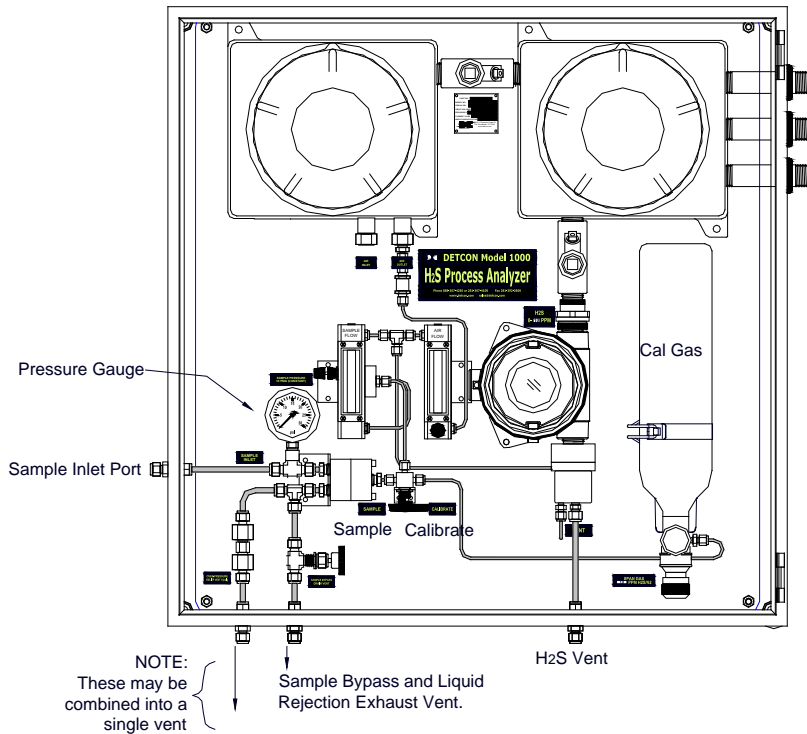

Figure 7 Unit Dimensions

#### 3.2 Gas Connections and Sampling System Notes

1. Install a length of tubing from the desired sample point to the sample input port (as shown in Figure 8). Sample draw tubing should be 316 stainless steel of 1/4" O.D.

**NOTE:** A constant pressure of 10±2psig should be provided to the analyzer for proper operation. In applications where line pressure varies significantly, two-stage pressure regulation is recommended to hold the constant pressure. Ideally, the pressure drop from the source to 10psig for analyzer should be taken as close to the pipeline as possible. This speeds up response time to actual gas concentration changes. An insertion probe membrane device is advisable to use for pipeline sources with high levels of condensates, mist, and contamination.



**Figure 8** Port Identification

2. Whenever possible, the Sample Bypass flow control valve of the Genie membrane filter should be used to minimize the sample lag time between the sample tap and the analyzer location. It can also be used as a means to exhaust condensed liquids in the sample line away from the Genie filter and prevent a “loss of flow” condition. Set a flow of 100-200cc/min. and vent to a safe area using ¼” O.D. tubing.
3. Connect to the Over-pressure Relief valve and vent to a safe area. The pressure relief valve is set at Detcon to open at 15-20psig. *For convenience sake, the sample bypass and over-pressure relief can be vented together.*
4. Install a length of ¼” OD stainless steel tubing from the vent port to an area deemed safe for venting as shown below. Venting pressure should be in the range of 0±1psig and ambient pressure is highly preferred.
5. When the optional Acetic Acid Bubbler apparatus is used, prior to applying power and applying gas flow the bubbler should be filled to the maximum fill level with a 5% acetic acid solution. (Standard white vinegar is also acceptable).

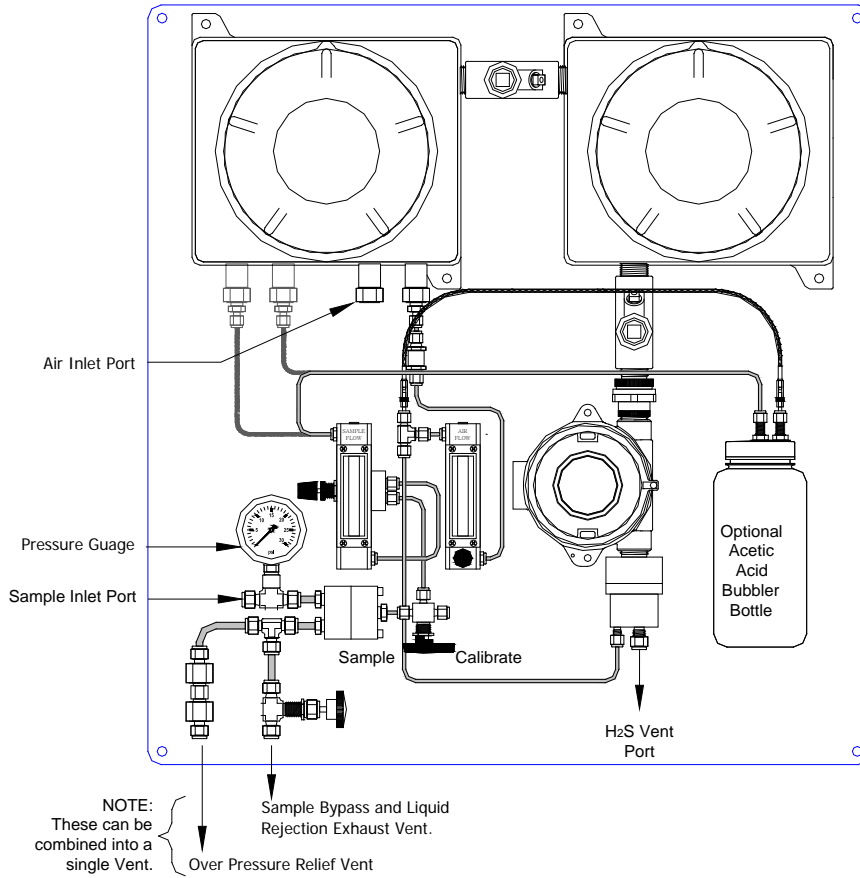

**Figure 9** Optional Bubbler Bottle

### 3.3 Electrical Connections

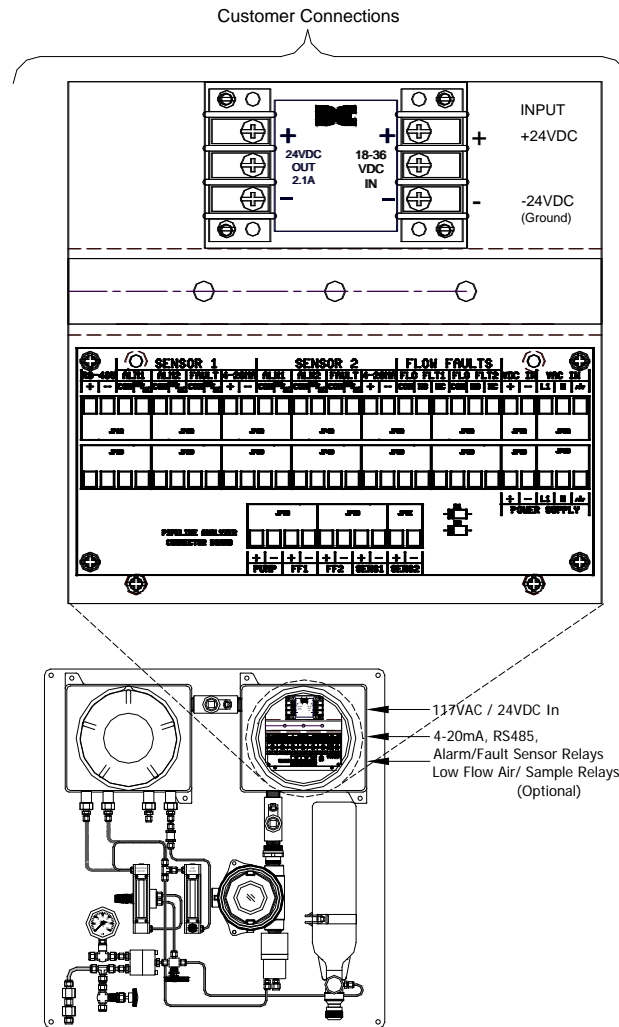
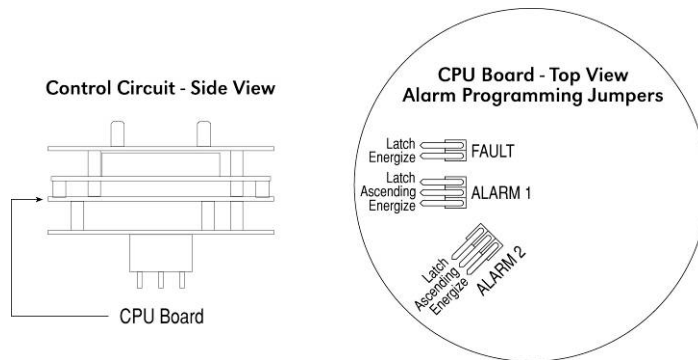

**Figure 10** Installation Wiring Connections

1. For AC powered unit connect 117/220VAC to the terminal connector labeled “VAC IN” (JP8A) inside the enclosure on the upper right. If applicable, connect 24VDC to the Terminal Connector Board labeled “VDC IN” (JP7A) (See Figure 10.)
2. The 4-20mA and/or RS-485 signal outputs should be wired from the terminal PCB and then out the right side of the “Power Supply” enclosure (Figure 10).
3. Discrete alarm relay contacts are provided for three alarms: Fault, Low and High. The contacts consist of common and choice of normally open or normally closed. Contact output selections are jumper programmable on the sensor connector board. See DM-624 wiring diagram for details. These connections also should be wired out of the right side of the “Power Supply” enclosure. (Figure 10).
4. Optional Low Flow Fault alarms for Sample gas and Air are available. They provide a form “C” relay contact (common, normally open and normally closed) rated 1 amp at 30VDC/0.24 amp at 125VAC. Relay contacts are pre-wired to the I/O connector PCB located in the “Power Supply” enclosure and are labeled “FLO FLT1” and “FLO FLT2” respectively (Figure 10).

### 3.4 Relays and RS-485 Setup

Program the alarms via the gold plated jumper tab positions located on the CPU board (Figure 11). Alarm 1 and Alarm 2 have three jumper programmable functions: latching/non-latching relays, normally energized/normally de-energized relays, and ascending/descending alarm set points. The fault alarm has two jumper programmable functions: latching/non-latching relay, and normally energized/normally de-energized relay. The default settings of the alarms (jumpers removed) are normally de-energized relays, non-latching relays, and alarm points that activate during descending gas conditions.



**Figure 11** Alarm Jumpers

If a jumper tab is installed in the latch position that alarm relay will be in the latching mode. The latching mode will latch the alarm after alarm conditions have cleared until the alarm reset function is activated. The non-latching mode (jumper removed) will allow alarms to de-activate automatically once alarm conditions have cleared.

If a jumper tab is installed in the energize position, that alarm relay will be in the energized mode. The energized mode will energize or activate the alarm relay when there is no alarm condition and de-energize or de-activate the alarm relay when there is an alarm condition. The de-energized mode (jumper removed) will energize or activate the alarm relay during an alarm condition and de-energize or de-activate the alarm relay when there is no alarm condition.

If a jumper tab is installed in the ascending position that alarm relay will be in the ascending mode. The ascending mode will cause an alarm to fire when the gas concentration detected is greater than or equal to the alarm set point. The descending mode (jumper removed) will cause an alarm to fire when the gas concentration detected is lesser than or equal to the alarm set point. Except in special applications, H<sub>2</sub>S monitoring will require alarms to fire in “ASCENDING” gas conditions.

Any unused jumper tabs should be stored on the connector board on the terminal strip labeled “Unused Jumpers”.

If applicable, set the RS-485 ID number via the two rotary dip switches located on the preamp board (see Figure 12). There are 256 different ID numbers available, which are based on the hexadecimal numbering system. If RS-485 communications are used, each sensor must have its own unique ID number. Use a jeweler’s screwdriver to set the rotary dipswitches according to Table 1 Hexadecimal Conversion. If RS-485 communications are not used, leave the dipswitches in the default position, which is zero/zero (0)-(0).

Replace the plug-in control circuit and replace the junction box cover.

**Table 1** Hexadecimal Conversion

ID#	SW1	SW2	ID#	SW1	SW2	ID#	SW1	SW2	ID#	SW1	SW2	ID#	SW1	SW2	ID#	SW1	SW2
none	0	0	43	2	B	86	5	6	129	8	1	172	A	C	215	D	7
1	0	1	44	2	C	87	5	7	130	8	2	173	A	D	216	D	8
2	0	2	45	2	D	88	5	8	131	8	3	174	A	E	217	D	9
3	0	3	46	2	E	89	5	9	132	8	4	175	A	F	218	D	A
4	0	4	47	2	F	90	5	A	133	8	5	176	B	0	219	D	B
5	0	5	48	3	0	91	5	B	134	8	6	177	B	1	220	D	C
6	0	6	49	3	1	92	5	C	135	8	7	178	B	2	221	D	D
7	0	7	50	3	2	93	5	D	136	8	8	179	B	3	222	D	E
8	0	8	51	3	3	94	5	E	137	8	9	180	B	4	223	E	F
9	0	9	52	3	4	95	5	F	138	8	A	181	B	5	224	E	0
10	0	A	53	3	5	96	6	0	139	8	B	182	B	6	225	E	1
11	0	B	54	3	6	97	6	1	140	8	C	183	B	7	226	E	2
12	0	C	55	3	7	98	6	2	141	8	D	184	B	8	227	E	3
13	0	D	56	3	8	99	6	3	142	8	E	185	B	9	228	E	4
14	0	E	57	3	9	100	6	4	143	8	F	186	B	A	229	E	5
15	0	F	58	3	A	101	6	5	144	9	0	187	B	B	230	E	6
16	1	0	59	3	B	102	6	6	145	9	1	188	B	C	231	E	7
17	1	1	60	3	C	103	6	7	146	9	2	189	B	D	232	E	8
18	1	2	61	3	D	104	6	8	147	9	3	190	B	E	233	E	9
19	1	3	62	3	E	105	6	9	148	9	4	191	B	F	234	E	A
20	1	4	63	3	F	106	6	A	149	9	5	192	C	0	235	E	B
21	1	5	64	4	0	107	6	B	150	9	6	193	C	1	236	E	C
22	1	6	65	4	1	108	6	C	151	9	7	194	C	2	237	E	D
23	1	7	66	4	2	109	6	D	152	9	8	195	C	3	238	E	E
24	1	8	67	4	3	110	6	E	153	9	9	196	C	4	239	F	F
25	1	9	68	4	4	111	6	F	154	9	A	197	C	5	240	F	0
26	1	A	69	4	5	112	7	0	155	9	B	198	C	6	241	F	1
27	1	B	70	4	6	113	7	1	156	9	C	199	C	7	242	F	2
28	1	C	71	4	7	114	7	2	157	9	D	200	C	8	243	F	3
29	1	D	72	4	8	115	7	3	158	9	E	201	C	9	244	F	4
30	1	E	73	4	9	116	7	4	159	9	F	202	C	A	245	F	5
31	1	F	74	4	A	117	7	5	160	A	0	203	C	B	246	F	6
32	2	0	75	4	B	118	7	6	161	A	1	204	C	C	247	F	7
33	2	1	76	4	C	119	7	7	162	A	2	205	C	D	248	F	8
34	2	2	77	4	D	120	7	8	163	A	3	206	C	E	249	F	9
35	2	3	78	4	E	121	7	9	164	A	4	207	C	F	250	F	A
36	2	4	79	4	F	122	7	A	165	A	5	208	D	0	251	F	B
37	2	5	80	5	0	123	7	B	166	A	6	209	D	1	252	F	C
38	2	6	81	5	1	124	7	C	167	A	7	210	D	2	253	F	D
39	2	7	82	5	2	125	7	D	168	A	8	211	D	3	254	F	E
40	2	8	83	5	3	126	7	E	169	A	9	212	D	4	255	F	F
41	2	9	84	5	4	127	7	F	170	A	A	213	D	5			
42	2	A	85	5	5	128	8	0	171	A	B	214	D	6			

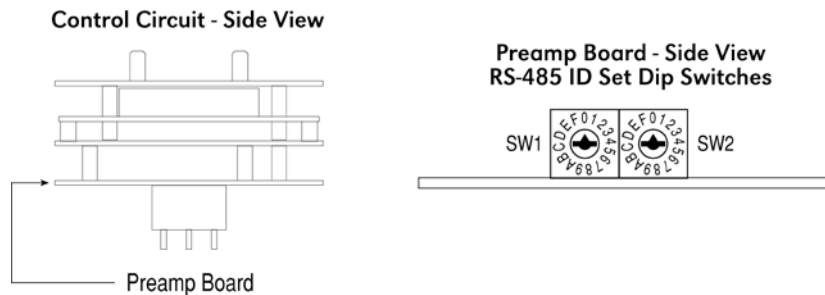

**Figure 12** RS-485 Dip Switches

## 4. Start Up

Upon completion of all tubing connections and field wiring the Model 1000 Series Process Analyzer is ready for startup. Note that after power is applied, varying readings may occur during sensor warm-up. Allow at least 1 hour for stabilization (24 hours is best). With sample gas and air flowing, apply system power and observe the following normal conditions:

- a) DM-624 “Fault” LED’s are off.
- b) A reading close to the anticipated H<sub>2</sub>S level should be indicated upon conclusion of a 1-minute “warming up” cycle.

---

**NOTE:** All alarms will be disabled for 1 minute after power up. In the event of power failure, the alarm disable period will begin again once power has been restored.

---

1. If applicable make sure the optional Acetic Acid Bubbler is filled with the proper solution. (5% acetic acid solution or standard white vinegar.)
2. Set the sample pressure to 10psig and verify the proper set point at the pressure gauge
3. Set the airflow through the Air sample rotameter. Adjust the rotameter flow valve to 250cc/min and in alignment with the “→” mark on the rotameter.

---

**NOTE:** Sample flow rates must be actual rotameter set-point flow rates, after properly accounting for rotameter gas density effects, see Table 2.

---

**Table 2** Sample Flow Rate

DM-624 Range (ppm)	Sample Flow (cc/min)	Air Flow (cc/min)	Span Gas Flow (cc/min)	H <sub>2</sub> S Cal Gas (ppm)
0-10	200 Labeled “S→”	500	250 Labeled “C→”	10
0-20	200 Labeled “S→”	500	250 Labeled “C→”	10
0-25	200 Labeled “S→”	500	250 Labeled “C→”	10
0-50	200 Labeled “S→”	500	250 Labeled “C→”	10 or 25
0-100	200 Labeled “S→”	500	250 Labeled “C→”	25 or 50
0-150	200 Labeled “S→”	500	250 Labeled “C→”	25 or 50
0-500	80 Labeled “S→”	1000	100 Labeled “C→”	100
0-1000	200 Labeled “S→”	500	250 Labeled “C→”	100 or 250
0-5000	200 Labeled “S→”	800	250 Labeled “C→”	1,000 or 2,500
0-10,000	80 Labeled “S→”	800	100 Labeled “C→”	2,500 or 5,000
0-5%	200 Labeled “S→”	1000	250 Labeled “C→”	1% or 2.5%

4. Adjust the sample mass flow controller valve per table above to meet the designated sample flow target mark labeled as “S→”. The “C→” indicator on the rotameter shows what Flow rate to calibrate at if the cal gas is N<sub>2</sub>. If the cal gas is in methane, then span gas flow should be set to “S→”.

---

**NOTE:** A displayed methane (typical natural gas) sample flow of 200cc/min. is actually equal to 250cc/min. of nitrogen when accounting for the 20% gas density affect on the rotameter. A displayed methane flow of 80cc/min. is actually 100cc/min. when accounting for the density effect.

---

5. Set the airflow rotameter per the Air Flow value in Table 2 that corresponds to the DM-624 Sensor Range.
6. Proceed with calibration per Section 6 Calibration and Maintenance.



## 5. Operating Software

### 5.1 Programming Magnet Operating Instructions

Operator interface to MicroSafe™ gas detection products is via magnetic switches located behind the transmitter faceplate. **DO NOT** remove the glass lens cover to calibrate or change programming parameters. Two switches labeled “PGM 1” and “PGM 2” allow for complete calibration and alarm level programming without removing the enclosure cover, thereby eliminating the need for area de-classification or the use of hot permits.



Figure 13 Programming Magnet

A magnetic programming tool (Figure 13) is used to operate the switches. Switch action is defined as momentary contact, 3-second hold, and 30-second hold. In momentary contact use, the programming magnet is waved over a switch location. In 3-second hold, the programming magnet is held in place over a switch location for 3 or more seconds. In 30-second hold, the programming magnet is held in place over a switch location for 30 or more seconds. Three and 30-second hold is used to enter or exit calibration and program menus while momentary contact is used to make adjustments. The location of “PGM 1” and “PGM 2” are shown in section 1.3.

---

**NOTE:** If, after entering the calibration or program menus, there is no interaction with the menu items for more than 30 seconds, the sensor will return to its normal operating condition.

---

### 5.2 Operating Software

Operating software is menu listed with operator interface via the two magnetic program switches located under the faceplate. The two switches are referred to as “PGM 1” and “PGM 2”. The menu list consists of 3 items which include submenus as indicated below.

01. Normal Operation
  - a) Current Status
02. Calibration Mode
  - a) Zero
  - b) Span
03. Program Menu
  - a) Program Status
  - b) Alarm 1 Level
  - c) Alarm 2 Level
  - d) Calibration Level

#### 5.2.1 Normal Operation

In normal operation, the display tracks the status of the sensor and gas concentration and appears as: “##.## PPM H2S”. The milliamp current output corresponds to the monitoring level and range of the sensor, where Full Scale is 20mA.

## 5.2.2 Calibration Mode

Calibration mode allows for sensor zero and span adjustments. It uses an “**AUTO SPAN**” sequence with built in diagnostics to ensure adequate sensor response and signal stability “**1-ZERO 2-SPAN**”.

### Zero Adjustment

Zero is set with no H<sub>2</sub>S target gases present. “**AUTO ZERO**”

### Span Adjustment

Span adjustment is performed with a target gas concentration of 10 ppm H<sub>2</sub>S in nitrogen. Span gas concentrations other than 10 ppm may be used “**AUTO SPAN**”. See Table 3 **Sample Flow Rate**.

## 5.2.3 Program Mode

Program Mode provides a program status menu (View Program Status) to check operational parameters. Program Mode also allows for the adjustment of alarm set point levels, the calibration gas level setting,

### View Program Status

View Program Status is a listing that allows the operator to view the gas, range, and software version number of the program, as well as the current alarm settings, calibration gas level setting, offset value, RS-485 ID number, heater voltage, and estimated remaining sensor life.

The following procedure is used to view the programming status of the sensor:

- a) Enter the programming menu by holding the programming magnet stationary over “PGM 2” for 15 seconds. When the display changes to “**VIEW PROG STATUS**”, withdraw the magnet. Scroll through the programming menu by momentarily waving the programming magnet over either “PGM 1” or “PGM 2”. The menu options are: View Program Status, Set Alarm 1 Level, Set Alarm 2 Level, and Set Cal Level.
- b) Scroll to the “**VIEW PROG STATUS**” listing and hold the programming magnet over “PGM 1” for 3 seconds. The display will automatically scroll, at five second intervals, through the following information before returning back to the “**VIEW PROG STATUS**” listing.
  - Gas type and software version number.
  - Alarm set point level of alarm 1. The menu item appears as: “**ALM1 SET @ ##PPM**”
  - Alarm firing direction of alarm 1. The menu item appears as: “**ALM1 ASCENDING**” or descending.
  - Alarm relay latch mode of alarm 1. The menu item appears as: “**ALM1 NONLATCHING**” or latching.
  - Alarm relay energize state of alarm 1. The menu item appears as: “**ALM1 DE-ENERGIZED**” or energized.
  - Alarm set point level of alarm 2. The menu item appears as: “**ALM2 SET @ ##PPM**”
  - Alarm firing direction of alarm 2. The menu item appears as: “**ALM2 ASCENDING**” or descending.
  - Alarm relay latch mode of alarm 2. The menu item appears as: “**ALM2 LATCHING**” or non-latching.
  - Alarm relay energize state of alarm 2. The menu item appears as: “**ALM2 DE-ENERGIZED**” or energized.
  - Alarm relay latch mode of the fault alarm. The menu item appears as: “**FLT NONLATCHING**” or latching.
  - Alarm relay energize state of the fault alarm. The menu item appears as: “**FLT ENERGIZED**” or de-energized.
  - Calibration gas level setting. The menu item appears as: “**CalLevel @ ##PPM**”
  - Identification of the RS-485 ID number setting. The menu item appears as: “**485 ID SET @ ##**”
  - Estimated remaining sensor life. The menu item appears as: “**SENSOR LIFE 100%**”

- c) Exit back to normal operations by holding the programming magnet over “PGM 2” for 3 seconds, or, the sensor will automatically return to normal operation in 30 seconds.

### **Alarm 1 Level Adjustment**

The alarm 1 level is adjustable over the range 10% to 90% of range. For hydrogen sulfide gas sensors, the level is factory set at 20% F.S. The menu item appears as: “**SET ALM1 @ ### PPM**”.

### **Alarm 2 Level Adjustment**

The alarm 2 level is also adjustable over the range 10% to 90% of range. For hydrogen sulfide gas sensors, the level is factory set at 60 % Full Scale. The menu item appears as: “**SET ALM2 @ ### PPM**”

### **Calibration Level Adjustment**

The Calibration level is adjustable from 10% to 90% of range. The menu item appears as: “**CAL LEVEL @ ## PPM**”

### 5.2.4 Software Flow Chart

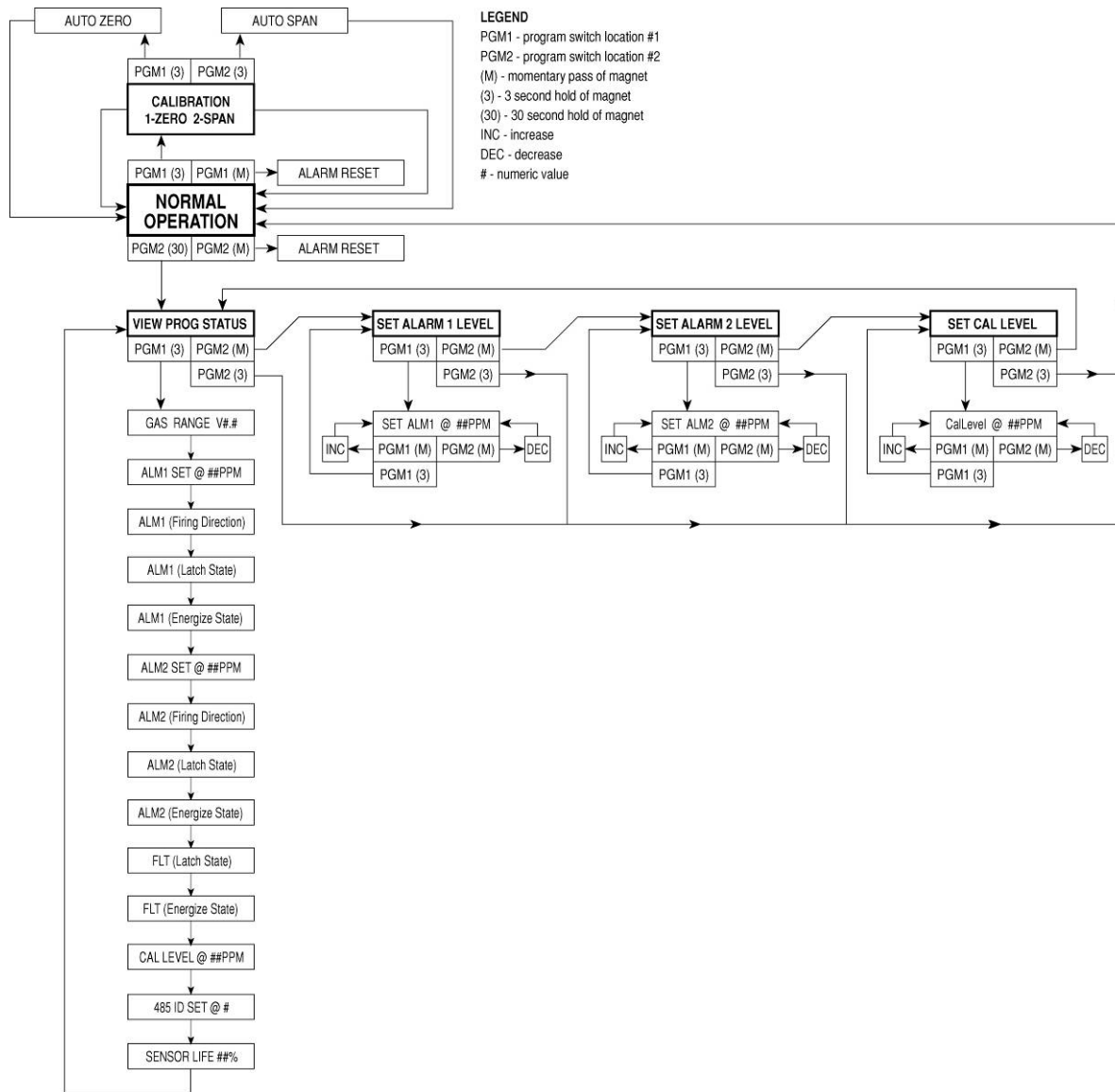

Figure 14 DM-624 Software Flow Chart

## 6. Calibration and Maintenance

The Model 1000 Series H<sub>2</sub>S Process Analyzer is calibrated prior to shipment. Only minimal adjustment should be required at time of commissioning. However, it is highly recommended that a zero and span calibration be performed twice in the first week of operation to assure optimum system performance. After that, a recalibration interval of every month is recommended.

### Maintenance

When the Acetic Acid Bubbler option is used, the 5% acetic acid solution (or white vinegar) should be kept near the Max fill mark on the bottle. The level should be checked monthly and the entire solution contents should be changed every 6 months.

## Material Requirements

- ✓ Detcon Part Number 327-000000-000 MicroSafe™ Programming Magnet.
- ✓ Detcon Part Number 942-001123-000 Zero Air cal gas. (Ambient air can be used, if it can be verified that no target gas is present).
- ✓ Span gas cylinder containing H<sub>2</sub>S gas in background N<sub>2</sub> (nitrogen) as per the following range table. If available, span gas cylinders in background Methane (natural gas) or air can also be used.

### 6.1.1 Zero Calibration

Zero Calibration should be performed quarterly in the field. The AutoZero function is used to zero the sensor. The dilution airflow (with sample turned off) can be used to zero calibrate the sensor. Alternately, a zero air or N<sub>2</sub> cylinder connected to the calibration port can be used.

- 1) Turn the sample flow mass control off, leaving only the airflow to provide the zero gas. Allow the unit 5 minutes to stabilize.
- 2) Enter the calibration menu by holding the programming magnet stationary over “PGM 1” (see above) for 3 seconds until the display reads “1-ZERO 2-SPAN”, and remove the magnet. Note that the “CAL” LED comes on.
- 3) Enter the zero menu by holding the magnet stationary over “PGM 1” for 3 seconds until the display reads: “AUTOZERO”, and remove the magnet. The sensor will enter the auto zero mode. When complete the sensor will display “ZERO COMPLETE” for 5 seconds and then return to the normal operation menu, “0.00PPM H2S”.
- 4) Re-open the sample flow mass control and re-establish the target sample flow rate per the arrow indicator on the H<sub>2</sub>S sample rotameter.

### 6.1.2 Span Calibration

Table 3 Sample Flow Rate

DM-624 Range (ppm)	Sample Flow (cc/min)	Air Flow (cc/min)	Span Gas Flow (cc/min)	H <sub>2</sub> S Cal Gas (ppm)
0-10	200 Labeled “S→”	500	250 Labeled “C→”	10
0-20	200 Labeled “S→”	500	250 Labeled “C→”	10
0-25	200 Labeled “S→”	500	250 Labeled “C→”	10
0-50	200 Labeled “S→”	500	250 Labeled “C→”	10 or 25
0-100	200 Labeled “S→”	500	250 Labeled “C→”	25 or 50
0-150	200 Labeled “S→”	500	250 Labeled “C→”	25 or 50
0-500	80 Labeled “S→”	1000	100 Labeled “C→”	100
0-5000	200 Labeled “S→”	800	250 Labeled “C→”	1000 or 2500
0-10,000	80 Labeled “S→”	800	100 Labeled “C→”	2,500 or 5,000
0-5%	200 Labeled “S→”	1000	250 Labeled “C→”	1% or 2.5%



**CAUTION:** Verification of the correct calibration gas level setting and calibration span gas concentration is required before “span” calibration. These two numbers must be equal.

Span Calibration consists of entering the calibration function and following the menu-displayed instructions. The display will ask for the application of span gas in a specific concentration. The concentration must be equal to the calibration gas level setting. See Table 3 Sample Flow Rate above for recommended cal gas concentrations. Other concentrations may be used as long as they fall between 10% and 90% of range. However, any alternate span gas concentration value must be programmed via the calibration gas level menu before proceeding with span calibration. Follow the instructions below for span calibration.

- 1) Verify that the current calibration gas level is equal to the calibration span gas concentration. (Refer to Section 5.2.3 Program Mode, “**View Sensor Status**”. The item appears as “**CAL LEVEL @ ### PPM**”.)
- 2) If the calibration gas level setting is equal to the calibration span gas concentration, proceed to item “3)”. If the calibration gas level setting is not equal to the calibration span gas concentration, adjust the calibration gas level setting so that it is equal to the calibration span gas concentration.
  - a) Enter the programming menu by holding the programming magnet stationary over “PGM 2” for 30 seconds. When the display reads “**VIEW PROG STATUS**”, withdraw the magnet. Scroll through the programming menu by momentarily waving the programming magnet over “PGM 1” or “PGM 2”. The menu options are: View Program Status, Set Alarm 1 Level, Set Alarm 2 Level, Set Heater Level, and Linearize Sensor.
  - b) From the programming menu scroll to the calibration level listing. The menu item appears as: “**SET CAL LEVEL**”. Enter the menu by holding the programming magnet stationary over “PGM 1” for 3 seconds until the display reads “**CAL LEVEL @ ### PPM**”, and withdraw the magnet. Use the programming magnet to increase (PGM 1) or decrease (PGM 2) the display reading until the reading is equal to the desired calibration span gas concentration.
  - c) Exit to the programming menu by holding the programming magnet over “PGM1” for 3 seconds.
  - d) Exit back to normal operation by holding the programming magnet over “PGM 2” for 3 seconds, or, the sensor will automatically return to normal operation in 30 seconds.
- 3) Enter the calibration span menu by holding the programming magnet stationary over “PGM 1” for 3 seconds. The display will read “**1-SPAN 2-EXIT**”. Hold programming magnet stationary over “PGM 1” for 3 seconds to proceed with span. “**APPLY ## PPM**” will appear in the display for 10 seconds.
- 4) Turn the H<sub>2</sub>S 3-way valve so that the arrow is pointing toward the cal gas source. The sample is now being drawn from the H<sub>2</sub>S Calibration Port.
- 5) Turn the fixed flow regulator on the Cal Gas Bottle to the “ON” position, and set the sample rotameter mass flow valve so the flow is set to “C” on the rotameter. The airflow should be set per the Air Flow table. (See Table 3 for these values).
- 6) As the sensor signal changes, the display will change to “**AUTOSPAN ###**”. Where “###” indicates the actual gas reading. The reading will increase/decrease until the sensor stabilizes. When the sensor signal is stable, the sensor will auto span to the requested concentration and the display will change to “**SPAN COMPLETE**” for two seconds and then “**REMOVE GAS**” for 3 seconds. The analyzer will then return to normal operation. The Auto Span sequence takes approximately 5 minutes.
- 7) Turn the fixed flow regulator on the Cal Gas Bottle to the “OFF” position and remove the gas.

---

**NOTE:** If the circuitry is unable to adjust the span to the proper setting the sensor will enter into the calibration fault mode which will cause the display to alternate between the sensor’s current status reading and the calibration fault display: “**CAL FAULT**”.

---

- 8) Turn the 3-way valve so that the arrow is pointing toward the sample source. Establish the target sample gas flow through the sample rotameter adjusting the flow rate to the “S” reading. Set the air rotameter per Table 3 (Air Flow column) and the appropriate H<sub>2</sub>S gas range for the analyzer.

Span calibration is complete. The total time for span calibration is approximately 10 minutes.

### **Additional Notes**

- a) Upon entering the calibration menu, the 4-20mA signal drops to 2mA and is held at this level until the sensor returns to normal operation.
- b) If during calibration the sensor circuitry is unable to attain the proper adjustment for span, the sensor will enter into the calibration fault mode which will activate fault alarm functions and cause the display to alternate between the sensor’s current status reading and the calibration fault screen which appears as: “**CAL FAULT**”. If this occurs, attempt to recalibrate by re-entering the calibration menu. If the sensor fails again, refer to Section 13, Troubleshooting.

- c) After span calibration, the alarm relays remain inactive until the sample gas concentration falls below both set alarm levels. The alarms will then become active again.

## 7. Programming Alarms

Both alarm 1 and alarm 2 levels are factory set prior to shipment. Alarm 1 is set at 20% of full-scale range; alarm 2 at 40% of full-scale range. Both alarms can be set from 10 to 90% of full-scale range. The following procedure is used to change alarm set points:

- a) Enter the programming menu by holding the programming magnet stationary over “PGM 2” for 30 seconds until the display reads “**VIEW PROG STATUS**”, and withdraw the magnet. Scroll through the programming menu by momentarily waving the programming magnet over “PGM 1” or “PGM 2”. The menu options are: View Program Status, Set Alarm 1 Level, Set Alarm 2 Level, and Set Cal Level.
- b) ALARM 1 LEVEL: From the programming menu scroll to the alarm 1 level listing. The menu item appears as: “**SET ALARM 1 LEVEL**”. Enter the menu by holding the programming magnet stationary over “PGM 1” for 3 seconds until the display reads “**SET ALM1 @ ###PPM**”, and withdraw the magnet. Use the programming magnet to adjust the display reading using “PGM 1” to increase or “PGM 2” to decrease the reading until the desired alarm set point is reached. Exit to the programming menu by holding the programming magnet over “PGM1” for 3 seconds.
- c) ALARM 2 LEVEL: From the programming menu scroll to the alarm 2 level listing. The menu item appears as: “**SET ALARM 2 LEVEL**”. Enter the menu by holding the programming magnet stationary over “PGM 1” for 3 seconds until the display reads “**SET ALM2 @ ###PPM**”, and withdraw the magnet. Use the programming magnet to adjust the display reading using “PGM 1” to increase or “PGM 2” to decrease the reading until the desired alarm set point is reached. Exit to the programming menu by holding the programming magnet over “PGM1” for 3 seconds.
- d) Exit back to normal operations by holding the programming magnet over “PGM 2” for 3 seconds, or, the sensor will automatically return to normal operation in 30 seconds.

### 7.1 Alarm Reset

An alarm condition will cause the applicable alarm to activate its corresponding relay and LED. If alarm 1, alarm 2, or fault alarms have been programmed for latching relays, an alarm-reset function must be activated to reset the alarms after an alarm condition has cleared. To reset the alarms, simply wave the programming magnet over either “PGM 1” or “PGM 2”, momentarily, while in normal operations mode and note that the corresponding alarm LED(s) turn off.

### 7.2 Other Alarm Functions

Alarms are factory programmed to be non-latching, de-energized; and to fire under ascending gas conditions. The fault alarm relay is programmed as normally energized which is useful for detecting a 24VDC power source failure. All alarm functions are programmable via jumper tabs. Changing alarm functions requires the sensor housing to be opened, thus declassification of the area is required.

## 8. Programming Features

Detcon MicroSafe™ H<sub>2</sub>S gas sensors incorporate a comprehensive program to accommodate easy operator interface and fail-safe operation. Program features are detailed in this section. Each sensor is factory tested, programmed, and calibrated prior to shipment.

## Over Range

When the sensor detects gas greater than 100% of its range, it will cause the display to flash the highest reading of its range on and off.

## Under Range Faults

If the sensor should drift below the zero baseline by approximately 10% of range, the display will indicate a fault: “**ZERO FAULT**”. If the sensor drifts below the normal zero baseline by approximately -30% of range, the display will indicate a “**SIGNAL FAULT**”.

## Calibration Fault

If during calibration the sensor circuitry is unable to attain the proper adjustment for zero or span, the sensor will enter into the calibration fault mode and cause the display to alternate between the sensor’s current status reading and the calibration fault screen which appears as: “**CAL FAULT**”.

## Fail-Safe/Fault Supervision

Detcon MicroSafe™ sensors are programmed for fail-safe operation. Either fault condition will activate the fault relay, illuminate the fault LED, and cause the display to read its corresponding fault condition: “**SIGNAL FAULT**”, or “**CAL FAULT**”. A “**SIGNAL FAULT**” will also cause the mA output to drop to zero (0) mA.

## Sensor Life

The sensor life feature is a reference based on signal output from the sensor cell. When a sensor life of 25% or less remains the sensor cell should be replaced within a reasonable maintenance schedule.

# 9. RS-485 Protocol

Detcon MicroSafe™ sensors feature Modbus™ compatible communications protocol and are addressable via rotary dip switches for multi-point communications. Other protocols are available. Contact the Detcon factory for specific protocol requirements. Communication is two wire, half duplex 485, 9600 baud, 8 data bits, 1 stop bit, no parity, with the sensor set up as a slave device. A master controller up to 4000 feet away can theoretically poll up to 256 different sensors. This number may not be realistic in harsh environments where noise and/or wiring conditions would make it impractical to place so many devices on the same pair of wires. If a multi-point system is being utilized, each sensor should be set for a different address. Typical address settings are: 01, 02, 03, 04, 05, 06, 07, 08, 09, 0A, 0B, 0C, 0D, 0E, 0F, 10, 11, etc.

In most instances, RS-485 ID numbers are factory set or set during installation before commissioning. If required, the RS-485 ID number can be set via rotary dip switches located on the preamp circuit board. However, any change to the RS-485 ID number would require the sensor housing to be opened, thus declassification of the area would be required. See section 3.5.4-f for details on changing the RS-485 ID number.

The following section explains the details of the Modbus™ protocol that the Detcon MicroSafe™ sensor supports.

**Code 03** - Read Holding Registers is the only code supported by the transmitter. Each transmitter contains 6 holding registers which reflect its current status.

Register #	High Byte	Low Byte
40000	Gas type	Sensor Life

Gas type is one of the following:

01=CO, 02= H<sub>2</sub>S, 03=SO<sub>2</sub>, 04=H<sub>2</sub>, 05=HCN, 06=CL<sub>2</sub>, 07=NO<sub>2</sub>, 08=NO, 09=HCL, 10=NH<sub>3</sub>, 11=LEL, 12=O<sub>2</sub>



Sensor life is an estimated remaining use of the sensor head, between 0% and 100%

Example: 85=85% sensor life

Register #	High Byte	Low Byte
40001	Detectable	Range

i.e. 100 for 0-100 ppm, 50 for 0-50% LEL, etc

Register #	High Byte	Low Byte
40002	Current Gas Reading	

The current gas reading as a whole number: If the reading is displayed as 23.5 on the display, this register would contain the number 235.

Register #	High Byte	Low Byte
40003	Alarm 1 Set point	

This is the trip point for the first alarm.

Register #	High Byte	Low Byte
40004	Alarm 2 Set point	

This is the trip point for the second alarm.

Register #	High Byte	Low Byte
40005	Status Bits	Status Bits

High Byte

Bit 7	Not used, always 0
Bit 6	Not used, always 0
Bit 5	Not used, always 0
Bit 4	Not used, always 0
Bit 3	1-Unit is in calibration 0-Normal operation
Bit 2	1-Alarm 2 is ascending 0-Alarm 2 is descending
Bit 1	1-Alarm 2 is normally energized 0-Alarm 2 is normally de-energized
Bit 0	1-Alarm 2 is latching 0-Alarm 2 is non-latching

Low Byte

Bit 7	1-Alarm 2 Relay is energized 0-Alarm 2 Relay is not energized
Bit 6	1-Alarm 1 is ascending 0-Alarm 1 is descending
Bit 5	1-Alarm 1 is normally energized 0-Alarm 1 is normally de-energized
Bit 4	1-Alarm 1 is latching 0-Alarm 1 is non-latching
Bit 3	1-Alarm 1 Relay is energized 0-Alarm 1 Relay is not energized
Bit 2	1-Fault is normally energized 0-Fault is normally de-energized
Bit 1	1-Fault is latching 0-Fault is non-latching
Bit 0	1-Fault Relay is energized 0-Fault Relay is not energized

The following is a typical Master Query for device # 8:

Field Name	HEX	DEC	RTU
Slave Address	08	8	0000 1000
Function	03	3	0000 0011
Start Address Hi	00	0	0000 0000

```

Start Address Lo      00    0    0000 0000
No. of Registers Hi  00    0    0000 0000
No. of Registers Lo  06    6    0000 0110
CRC ## ##### #####
CRC ## ##### #####

```

The following is a typical Slave Response from device # 8:

Field Name	HEX	DEC	RTU
Slave Address	08	8	0000 1000
Function	03	3	0000 0011
Byte Count	0C	12	0000 1100
Reg40000 Data Hi	02	2	0000 0010
Reg40000 Data Lo	64	100	0110 0100
Reg40001 Data Hi	00	0	0000 0000
Reg40001 Data Lo	64	100	0110 0100
Reg40002 Data Hi	00	0	0000 0000
Reg40002 Data Lo	07	7	0000 0111
Reg40003 Data Hi	00	0	0000 0000
Reg40003 Data Lo	0A	10	0000 1010
Reg40004 Data Hi	00	0	0000 0000
Reg40004 Data Lo	14	20	0001 0100
Reg40005 Data Hi	05	5	0000 0101
Reg40005 Data Lo	50	80	0101 0000
CRC ## ##### #####			
CRC ## ##### #####			

**Additional Notes:**

The calibration LED will light when the transmitter is sending a response to a Master Query. Communications are 9600 baud, 8 data bits, 1 stop bit, No parity, and half duplex 485.

## 10. Display Contrast Adjustment

Detcon MicroSafe™ sensors feature a 16 character backlit liquid crystal display. Like most LCDs, character contrast can be affected by viewing angle and temperature. Temperature compensation circuitry included in the MicroSafe™ design will compensate for this characteristic; however temperature extremes may still cause a shift in the contrast. Display contrast can be adjusted by the user if necessary. However, changing the contrast requires that the sensor housing be opened, thus declassification of the area is required.

To adjust the display contrast, remove the enclosure cover and use a jeweler’s screwdriver to turn the contrast adjust screw located beneath the metallic face plate. The adjustment location is marked “**CONTRAST**”.

## 11. Low Flow Fault Options

Model 1000 Analyzers offer two low flow fault option PCB’s. One monitors for low sample gas flow, and the second monitors for low airflow dilution. The Low Flow Fault option for sample gas flow is usually set for the relay contacts to fire at flow rates ≤ 100cc/min. The Flow Fault option for air dilution is usually set for the relay contacts to fire at flow rates ≤ 300cc/min. These set points are factory set. Should it become necessary to adjust the flow fault set points in the field, adjust the flow to the set point target (100 or 300cc/min.) at rotameter(s) and adjust the potentiometer on the corresponding Low Flow Fault PCB until the fault LED toggles between “ON” and “OFF”.

## 12. Sensor Replacement

Should the electrochemical H<sub>2</sub>S plug-in sensor (part number 370-323200-000 or 370-3H3H00-000) require replacement, use the following procedure:

- 1 - (A) If the sensor is mounted in a classified area, system power to the transmitter must first be removed before proceeding further.  
(B) If in an unclassified area, remove front enclosure cover and unplug transmitter module.
- 2 - Remove gas flow adapter and tubing connections to expose sensor housing.
- 3 - Unscrew the three screws of the sensor head bottom.
- 4 - Pull the sensor head bottom down and off.
- 5 - Grasp the electrochemical sensor cell and unplug by pulling down.
- 6 - Plug in the new sensor. Replace the sensor head bottom and screw in place.
- 7 - Re-attach gas inlet adapter and tubing connections.
- 8 - Restore system power (if classified) or plug in transmitter module and replace enclosure cover (if unclassified).
- 9 - Perform a new zero and span calibration after 1-2 hours of warm-up time.

## 13. Troubleshooting

Reading higher or lower than anticipated

Probable cause: Incorrect sample flow or air flow, degraded cal gas, or needs to be zero and span calibrated.

1. Check for correct sample flow “S→” marking 200cc/min.
2. Check for correct air flow “→” marking 500cc/min.
3. Check span gas is same as programmed AutoSpan value.
4. Check Span Calibration gas for valid concentration in nitrogen gas using H<sub>2</sub>S pull tube.
5. Re-calibrate sensors with known good span gas.
6. Re-zero sensor per instruction manual.

### “Span Fault” Error

1. Check for correct calibration gas flow “C→” marking, 250cc/min.
2. Check for correct air flow “→” marking, 500cc/min.
3. Check Span Calibration gas for valid concentration in nitrogen gas using H<sub>2</sub>S pull tube.
4. Re-calibrate with known good span gas.
5. Consider electrochemical sensor replacement if reported Sensor Life is <50%.

Slow sensor response during Span Calibration

Probable cause: Incorrect sample flow or airflow, or bad span gas, or slow response sensor.

1. Check for correct calibration gas flow “C→” marking, 250cc/min.
2. Check for correct air flow “→” marking, 500cc/min.
3. Check Span Calibration gas for valid concentration in nitrogen gas.
4. Re-calibrate with known good span gas.
5. If problem persists, the sensor may need to be replaced. Contact factory.

Sample gas and/or air flow reduced, Flow Fault lights activated (optional)

Probable cause: Incorrect sample gas inlet pressure or the sample gas or airflow has been obstructed by, blocked Genie membrane filter, failed air pump, vent lines blocked, rotameters accidentally turned down.

1. Check for liquid in the sample flow inlet line.
2. Check for adequate sample gas inlet pressure (10 ±2psig).
3. Check for obstruction in the air-inlet pump.
4. Open the Sample by-pass liquid rejection port to release any liquid trapped in the Genie Membrane filter. Leave sample by-pass open to allow ~100-200cc/min of gas out.
5. Replace Genie membrane if permanently blocked.

# 14. Spare Parts

Part#	Description
327-000000-000	Programming Magnet
351-152021-400	24 VDC Pump Assembly
360-2424AS-030	24V DC-DC Converter
943-200000-000	Activated Carbon Scrubber
360-205421-024	24 VDC Power Supply
943-010013-505	500 CC Fixed Flow Regulator
823-101085-882	Genie Membrane Filter
350-300000-000	0.5Lpm Rotameter no valve
348-900000-000	1Lpm Rotameter with valve
350-523081-02K	Mass flow controller
955-004229-000	Bubbler Bottle Assembly

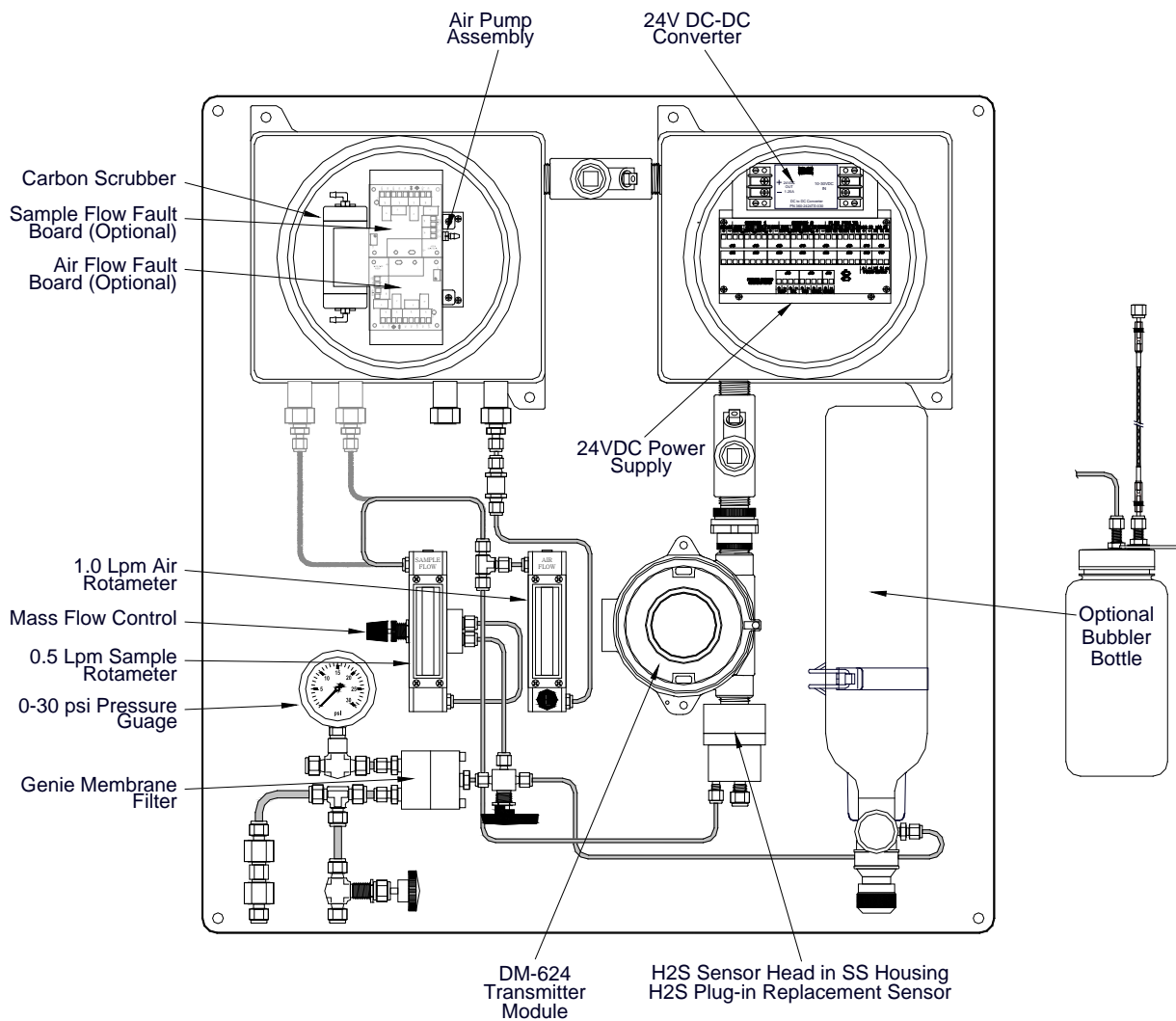

**Figure 15** Analyzer Parts Identification

### Spare Parts DM-624 H<sub>2</sub>S Sensor

Part#	Description
942-010212-XXX	Calibration Span Gas (XXXppm H <sub>2</sub> S, balance nitrogen) (Where XXX denotes the gas level – 010 = 10ppm, 025 = 25ppm, 050 = 50ppm)
942-010213-XXX	Calibration Span Gas (XXX% H <sub>2</sub> S, balance nitrogen) (Where XXX denotes the gas level – 001 = 1%, 1X5 = 1.5%, 2X5 = 2.5%)
926-245502-XXX	Transmitter Module XXXppm Range (for H <sub>2</sub> S Alcohol Free gas sensor) (Where XXX denotes the Range – i.e.: 005 = 0-5ppm, 010 = 0-10ppm, 020 = 0-20ppm, etc)
4040-H2S32-NXX	Sensor Housing Assembly (Where XX denotes Range – i.e.: N05 = 0-5ppm, N10 = 0-10ppm, N20 = 0-20ppm, etc.)
404-0H2S3H-NXX	Sensor Housing Assembly for High Range (Where XX denotes Range – i.e.: N1K = 0-1000ppm, N5K = 0-5000ppm, N1P = 0-1%, etc.)
017-501500-574	O-Ring 1.5”ID X 1.6”OD X 0.05”W
017-26530H-000	O-Ring 1 3/16”ID X 1 3/8”OD X 0.103”W
370-323200-000	Alcohol Free Replacement H <sub>2</sub> S Cell (used for ranges <1000ppm)
370-3H3H00-000	High Range H <sub>2</sub> S Cell (Used for ranges ≥1000ppm)

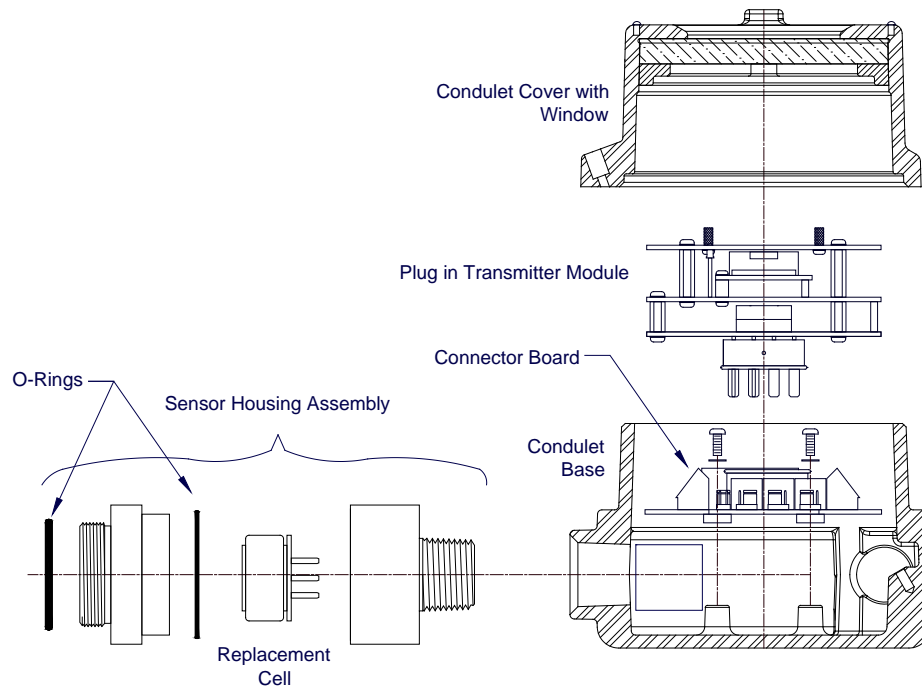

**Figure 16** DM-624 Replacement Parts

## 15. Warranty

Detcon Inc., as manufacturer, warrants under intended normal use each new Model 1000 Series H<sub>2</sub>S Process Analyzer gas detection system to be free from defects in material and workmanship for a period of one year from the date of shipment to the original purchaser. All warranties and service policies are FOB the Detcon Inc. facility located in The Woodlands, Texas.

### Sensor Transmitter

Detcon, Inc., as manufacturer, warrants under intended normal use each new MicroSafe™ plug-in control circuit to be free from defects in material and workmanship for a period of two years from the date of shipment to the original purchaser.

Detcon, Inc., further provides for a five year fixed fee service policy wherein any failed transmitter shall be repaired or replaced as is deemed necessary by Detcon, Inc., for a fixed fee of \$65.00. The fixed fee service policy shall affect any factory repair for the period following the two-year warranty and shall end five years after expiration of the warranty. All warranties and service policies are FOB the Detcon facility located in The Woodlands, Texas.

### DM-624 Electrochemical H<sub>2</sub>S Sensor Element Warranty

Detcon, Inc., as manufacturer, warrants each hydrogen sulfide sensor cell (part no. 370-323200-000), for a 6-month period under the conditions described as follows: The warranty period begins on the date of shipment to the original purchaser and ends six months thereafter. The sensor cell is warranted free from defects in material and workmanship. Should any sensor cell fail to perform in accordance with published specifications within the warranty period, return the defective part to Detcon, Inc.

- ❖ The original serial number must be legible on each sensor element base.
- ❖ Shipping point is FOB the Detcon Factory.
- ❖ Net payment is due within 30 days of invoice.
- ❖ Detcon, Inc. reserves the right to refund the original purchase price in lieu of sensor replacement.

### Terms & Conditions

- ❖ The original serial number must be legible on each sensor element base.
- ❖ Shipping point is FOB the Detcon factory.
- ❖ Net payment is due within 30 days of invoice.
- ❖ Detcon, Inc. reserves the right to refund the original purchase price in lieu of sensor replacement.

# 16. Flow Diagrams

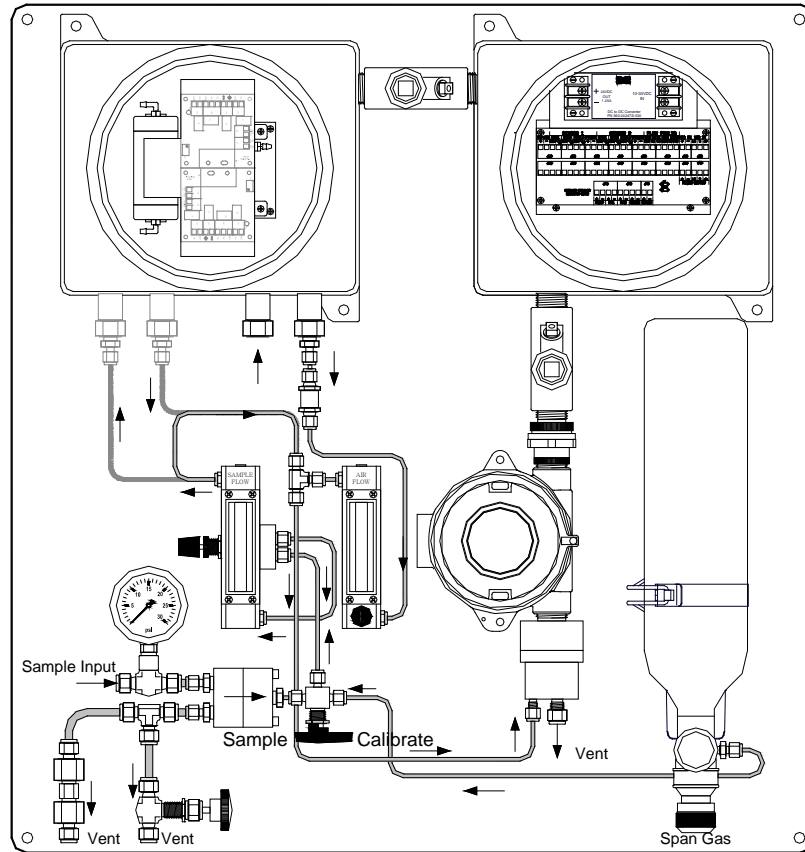
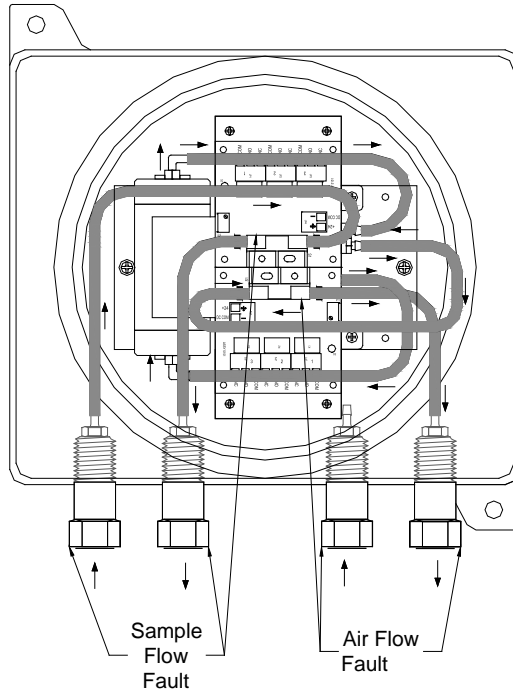

Figure 17 Unit Flow Diagram



**Figure 18** Pump Box Flow Diagram



# 17. Wiring Diagram

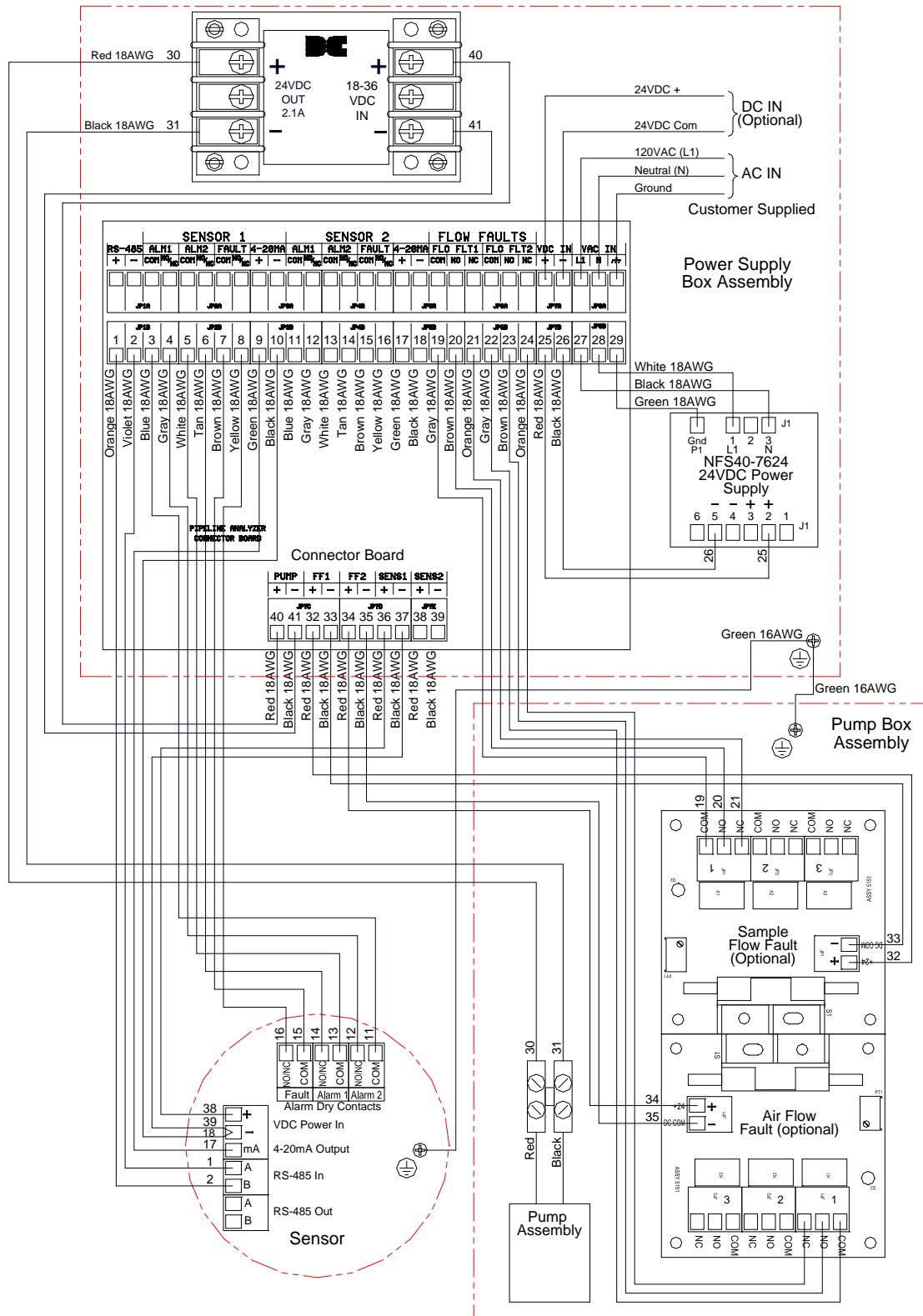

Figure 19 Wiring Diagram

# Appendix C

## Revision Log

Revision	Date	Changes made	Approval
2.3	02/12/09	Previous Revision	
2.4	09/04/09	Update Spare Parts	
2.5	07/06/10	Update Spare parts to reflect High Range sensor , Added new range (0-5%) to Sample Flow Rate tables	BM
2.6	06/02/11	Updated drawings and Spare Parts List to show Detcon Aluminum conduit	LU
2.7	09/19/11	Updated notation for VDC input in section 3.3 to match wiring diagram	LU
2.8	06/06/12	Added new range 0-1000ppm	BM
2.9	05/03/18	Classifications Updated	MM