

INSTRUCTION MANUAL

Sensepoint XCL

Fixed Point Gas Detector



Honeywell

About This Manual

This manual describes how to install and use the Sensepoint XCL gas detector and should be read by anyone who installs, operates, or maintains these products.

Read and understand this manual in full before you install the product.

While every effort has been made to ensure the accuracy of this document, Honeywell can assume no responsibility for any errors or omissions or their consequences. Honeywell would greatly appreciate being informed of any errors or omissions that may be found in the content of this document. For information not covered in this document, or to send comments or corrections, please contact Honeywell using the contact details given on the back page.

Honeywell reserves the right to change or revise the information supplied in this document without notice and without obligation to notify any person or organization of such revision or change.

REVISION HISTORY

ISSUE	ECO Number	DATE
4	HAA190009	May 2019
5	ECN-00210050	March 2021
6	ECN-00230030	May 2023

Contents

About This Manual	2
Contents	3
1 Introduction	6
1.1 Features.....	6
1.2 Appearance.....	7
1.3 Accessories.....	7
1.4 Detectable Gases.....	8
1.5 Detector Versions	8
Analog (mA) Output Versions	8
Modbus Output Versions	9
1.6 Relay Output.....	9
1.7 Specifications.....	10
Dimensions and Weight.....	10
Power Supply.....	10
Outputs.....	11
Maximum Power Consumption.....	11
Operating Environment.....	12
Recommended Wall-Mounting Screws.....	12
Cable Gland.....	12
Gas Test Tubing.....	12
Gas.....	13
2 Installation	14
2.1 Safety Information	14
2.2 Installation Layout.....	15
2.3 Power Cable Specification	15
2.4 Detector Module	17
2.5 Wiring of mA Output Versions	17
Power Connection.....	17
Inhibit Level Selection.....	18

Current Source/Sink Selection	18
2.6 Wiring of Modbus Output Versions.....	20
Modbus Connection.....	20
Cable Specification for Modbus Connection	21
Terminal Resistor.....	21
2.7 Securing the Back Box to a Wall.....	22
2.8 Cable Connections.....	22
2.9 Ground Connections.....	24
2.10 Securing the Detector Module to the Back Box	25
2.11 Remote Gassing Connection	26
3 Commissioning	28
3.1 Commissioning the Detector.....	28
3.2 Status Indicator.....	30
3.3 Target Gas Selection (flammable catalytic versions only).....	32
4 Maintenance	33
4.1 Using the Control Buttons	33
4.2 Maintenance Status Indicator.....	34
4.3 Calibration Cap.....	35
4.4 Calibration.....	37
4.5 Bump Test.....	39
4.6 Replacing the Sensor.....	40
4.7 Resetting Alarms and Faults.....	41
5 Mobile App	42
6 Security Guide	43
A Detector Parameters	44
B Troubleshooting	48
B.1 Warning.....	48
B.2 Fault.....	48
C Ordering Information	49
C.1 Detectors.....	49
C.2 Accessories.....	52
C.3 Consumables	52
C.4 Spares.....	52
D Warranty	53
E Safety Information for Wireless Devices	54
E.1 FCC Compliance	54

E.2 IC Compliance.....	55
E.3 RED Compliance.....	55
F Certification	56
G Modbus Registers	57
H Contact Information	62

Chapter 1

Introduction

1.1 Features

Sensepoint XCL is a single-sensor fixed gas detector, which supports the following interfaces dependent on the model:

Analog output: Sensepoint XCL features current loop output, supporting signals in the range 0 to 22 mA. Typically this interface is referred to as 4 to 20 mA.

Digital output: Sensepoint XCL supports Modbus RTU digital communications.

Relay output: Sensepoint XCL provides two change-over relays for signaling to external control systems or controlling external alarming devices, for example audible and visual alarm indicators.

Mobile app: A mobile app is available to commission and maintain the Sensepoint XCL gas detector.

Sensepoint XCL can be used either indoor or outdoors. If used outdoors, a sheltered location should be chosen, which is protected from direct sunlight and rain.

1.2 Appearance

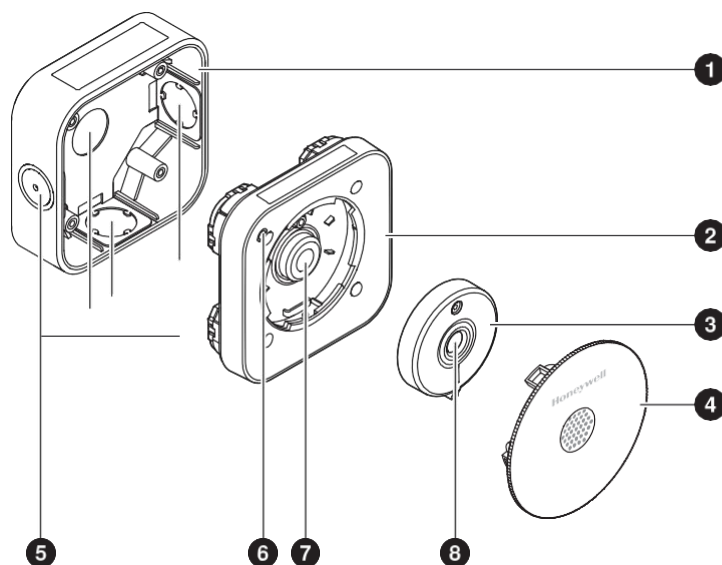

- | | |
|------------------|-----------------------------|
| 1) Back box | 2) Gas detector module |
| 3) Sensor cover | 4) Front cover |
| 5) Cable entries | 6) Status indicator |
| 7) Gas sensor | 8) Dust protection membrane |

1.3 Accessories

Part number	Description
SPXCLCAL	Sensepoint XCL Calibration/Flow Cap
SPXCLDMK	Sensepoint XCL Duct Mount Kit
SPXCLRGP	Sensepoint Fixed Remote Gassing Port
SPXCLGLD	Sensepoint XCL M20 Cable Glands, Black (10 pieces each pack)
SPXCLGLW	Sensepoint XCL M20 Cable Glands, White (10 pieces each pack)

1.4 Detectable Gases

Sensepoint XCL is available for the detection of the following gases:

- Oxygen (O₂)
- Toxic gases
 - Ammonia (NH₃)
 - Carbon monoxide (CO)
 - Hydrogen (H₂)
 - Hydrogen sulfide (H₂S)
 - Nitrogen dioxide (NO₂)
 - Carbon Dioxide (CO₂)
- Combustible gases
 - Methane (CH₄)

For additional combustible gas availability, contact Honeywell Analytics.

1.5 Detector Versions

The 4-way terminal block(s) provide connection for both the gas detector output and the power supply. Assignment of the terminals and additional terminal blocks will vary dependent on the version.

Analog (mA) Output Versions

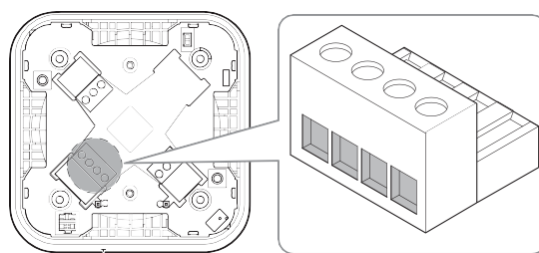

1) +24 V DC or 24 V AC
3) 4 to 20 mA

2) 0V or 24V AC
4) Common

For details on wiring for the analog output version, see **Wiring of mA Output Versions** on page 17 and also **Current Source/Sink Selection** on page 18.

Modbus Output Versions

NOTE

Use of the mobile app is required to change the configuration settings of the Modbus RTU interface.

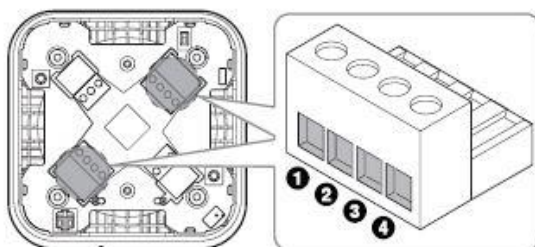

1) +24 V DC or 24 V AC

2) 0 V or 24 V AC

3) A

4) B

1.6 Relay Output

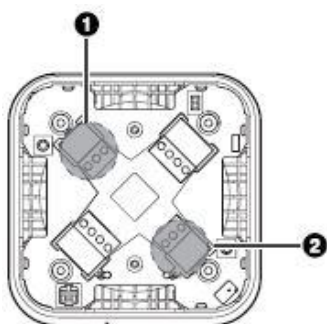

1) Relay No. 1

2) Relay No. 2

Where fitted, there are two configurable relays which can be used to control or signal to external devices, such as audible and visual alarms and other control systems.

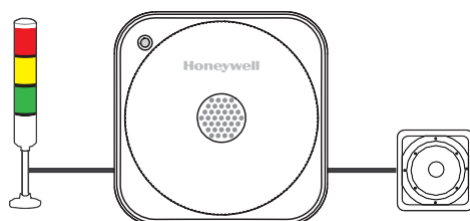

Connection to these relays are made through the two 3-way terminal blocks.

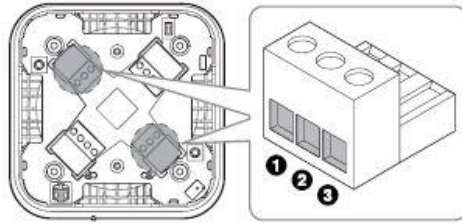

- | | |
|-------------------------|-----------|
| 1) Normally closed (NC) | 2) Common |
| 3) Normally open (NO) | |

1.7 Specifications

Dimensions and Weight

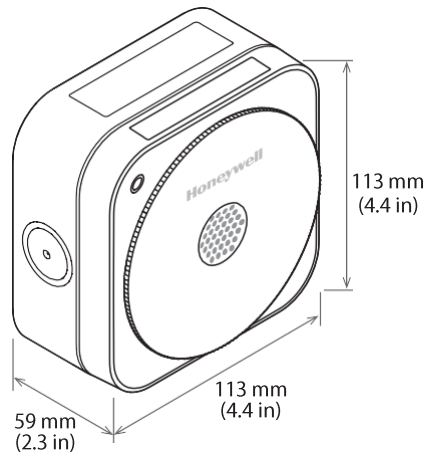

Length	113 mm (4.4 in)
Width	113 mm (4.4 in)
height	59 mm (2.3 in)
Weight	500 g (1.1 lb)

Power Supply

Sensepoint XCL requires an isolated power supply unit that is certified by a national or international standard, such as UL.

Nominal DC input voltage	24 V DC [†]
Nominal AC input voltage	24 V AC [‡] , 50/60 Hz
Inrush current	Less than 850 mA

[†]mA versions: 11 to 32 V DC, Modbus versions: 9 to 32 V DC
[‡]20 to 27 V AC

Outputs

Analog output	0 to 22 mA sink or source (configurable)
Digital output	Modbus RTU
Relay output	5 A, 250 V AC, 24 V DC

The two relays can be used for fault signalling (normally energized) or for alarm signalling. The relay assignments and operations are configurable using the mobile app.

Modbus RTU Default Communication Setting

Baudrate	9600 bps
Parity	None
Data bits	8
Stop bits	2
Flow control	None

Refer to Appendix G for details on the Modbus registers.

Adjustable Modbus setting:

- Slave ID: 1 to 255
- Baud rate: 9600, 19200 bps
- Parity: None, Even, Odd

Relay Default Setting

Relay 1	Any faults and initial state is energized.
Relay 2	Gas alarm 1 and initial state is de-energized.

Maximum Power Consumption

The power consumption varies, depending on output version and sensor type. The additional maximum power consumption for the relay output version is 0.6 W.

Analog Output Version

	In normal state	During an alarm
Electrochemical-cell-type sensors	0.5 W	1.2 W
Catalytic-type sensors	1.0 W	1.7 W
Infrared-type sensors	1.0 W	1.7 W

Digital Output Version

	In normal state	During an alarm
Electrochemical-cell-type sensors	0.3 W	0.7 W
Catalytic-type sensors	0.8 W	1.2 W
Infrared-type sensors	0.8 W	1.2 W

Operating Environment

Operating temperature	-20 to 50 °C (-4 to 122 °F)
Storage temperature	0 to 30 °C (32 to 86 °F)
Humidity	0 to 99% (non-condensing) [†]
Atmospheric pressure	90 to 110 kPa
Installation category	II (UL/CSA/IEC/EN 61010-1)
Pollution degree [‡]	2 (UL/CSA/IEC/EN 61010-1)

[†]Flammable catalytic versions: 10 to 90% RH. Operating the detector outside of this range may result in increased drift and a reduction in detector accuracy.

[‡]Sensepoint XCL conforms to IP65, Type 4 (in accordance with NEMA 250) making it suitable for use in Pollution Degree 3 environments.

NOTE

Install Sensepoint XCL in a sheltered location away from direct UV light and rain.

Recommended Wall-Mounting Screws

Type	Countersunk, pan head
Size	4 mm (No. 8) diameter × 25 mm (1 in) min.

Cable Gland

Inner knockout	M20 or ½ NPT
Outer knockout	M25 or ¾ NPT

Gas Test Tubing

For a bump test, use urethane tubing with one of the below dimensions. Select tubing appropriate for the gas being detected and length of tubing. See Remote Gassing Connection on page 26.

Inner diameter	Outer diameter
4 mm (0.16 in)	6 mm (0.24 in)
6 mm (0.24 in)	8 mm (0.31 in)

Gas

See Detector Parameters on page 42 for a full list of detectable gases, ranges and other information.

Chapter 2

Installation

2.1 Safety Information

 CAUTION

Failure to observe the precautions described in this section can cause injury to persons or damage to property.

Observe these precautions:

- To minimize the risk of electrostatic charge, provision shall be made for adequate grounding and equipment shall be installed in such a manner so that accidental discharge shall not occur.
- When Sensepoint XCL reaches the end of its life, it should be disposed of in accordance with local regulations.
- Do not use cleaning solvents or abrasives to clean the gas detector.
- Do not attempt to modify the product in any way from the manufacturer's design or specification. Warranty will be void and malfunction of the gas detector may result.
- Use only genuine spare parts and accessories with Sensepoint XCL. Malfunction may result if non-standard parts are used.

Sensepoint XCL is suitable for ordinary locations only and must not be installed in hazardous locations. Installation must be in accordance with the recognized standards of the appropriate authority in the country concerned. For Europe, see EN60079-14, EN60079-29-2, and EN61241-14. For installations in North America, the National Electrical Code (NFPA 70) should be strictly observed. All the appropriate local and national regulations should be observed.

2.2 Installation Layout

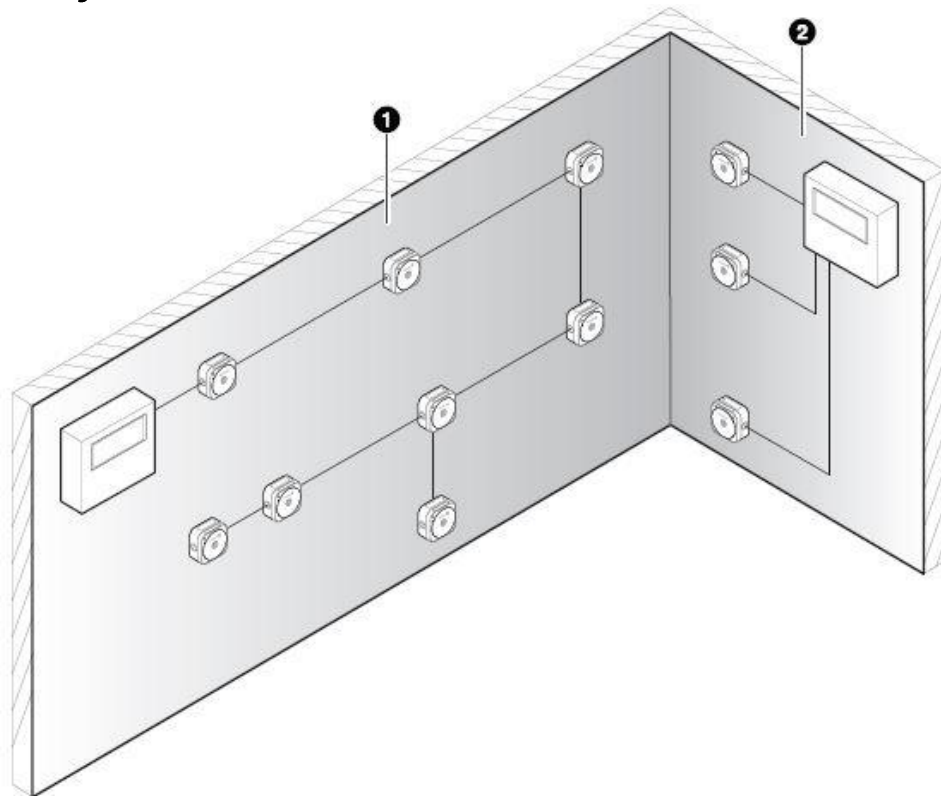

- 1) A gas detection system using Modbus RTU. Detectors are wired in a daisy chain on a single cable run.
- 2) A gas detector system using analog current loop principle. Each detector is individually wired to the controller on its own cable.

Final positioning of gas detectors should be indicated by the characteristics of the gas being detected and other environmental factors. Seek advice from experts where necessary.

2.3 Power Cable Specification

Sensepoint XCL requires a power supply from the controller of specified supply voltage range in Section 1.7. Ensure that a minimum supply voltage is measured at the Sensepoint XCL, taking into account voltage drops due to cable resistance.

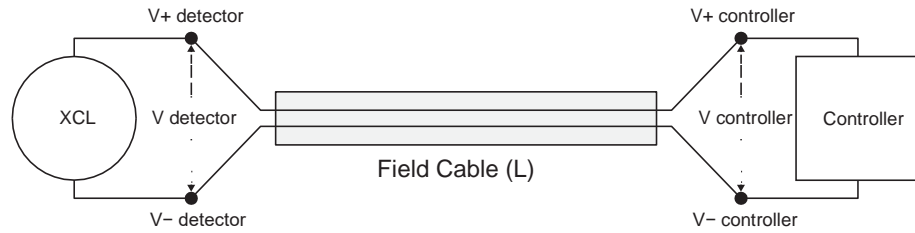

The maximum loop resistance ($R_{loop\ max}$) in the field cable is calculated as follows:

$$R_{loop\ max} = (V_{controller} - V_{detector\ min}) \div I_{detector\ max}$$

$$I_{detector\ max} = W_{detector\ max} \div V_{detector\ min}$$

Example

The controller is supplying a nominal 24 V DC ($V_{controller}$), and the minimum allowable voltage of XCL is 11 V DC ($V_{detector\ min}$). Therefore the maximum allowable voltage drop across the cable between the controller and detector is $V_{controller} - V_{detector\ min} = 13\ V\ DC$. Power consumption of the detector is maximum 2.3 W ($W_{detector\ max}$). The maximum current required to drive the XCL at the minimum voltage is $2.3\ W \div 11\ V\ DC = 209.1\ mA$ ($I_{detector\ max}$). So the maximum field cable loop resistance ($R_{loop\ max}$) is $13\ V\ DC \div 0.2091 = 62\ \Omega$. Therefore, the maximum cable length for any given cable type can be found by dividing the maximum allowable cable resistance per core by the cable resistance provided by the cable manufacturer.

The following table shows the typical maximum cable distances for our example.

Cable size (crosssectional area)	Typical cable resistance	Maximum cable length (L)
0.5 mm ² (20 AWG ¹)	36.8 Ω/km	842 m
1.0 mm ² (17 AWG ¹)	19.5 Ω/km	1589 m
1.5 mm ² (16 AWG ¹)	12.7 Ω/km	2440 m
2.0 mm ² (14 AWG ¹)	10.1 Ω/km	3069 m
2.5 mm ² (13 AWG ¹)	8.0 Ω/km	3875 m

¹nearest equivalent

2.4 Detector Module

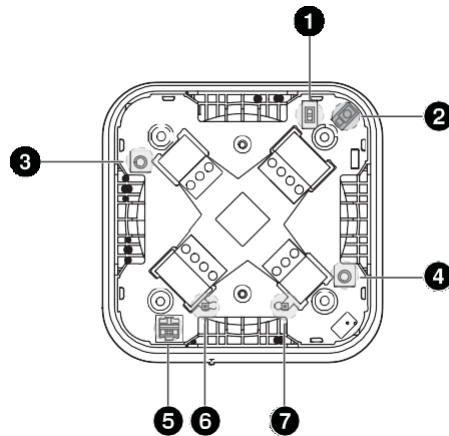

- 1) Inhibit switch
- 2) Status indicator
- 3) UP button
- 4) DOWN button
- 5) Current sink/source selection switch
- 6) Negative voltage output
- 7) Positive voltage output

2.5 Wiring of mA Output Versions

⚠ CAUTION

Ensure that the wiring of the detector is correct and the Current Source/Sink selection switch is correctly set BEFORE applying power. Failure to do so may result in damage to the Sensepoint XCL detector.

Power Connection

When connecting to DC power, make sure that the polarity is correct.

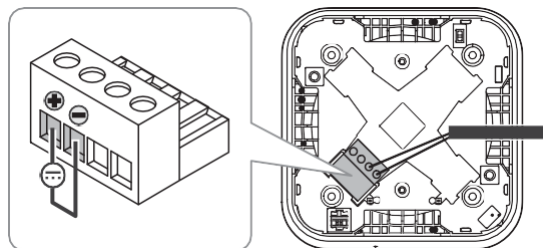

If an external power source is used, ensure that terminal 4 “Common” is used to connect the power and controller grounds together.

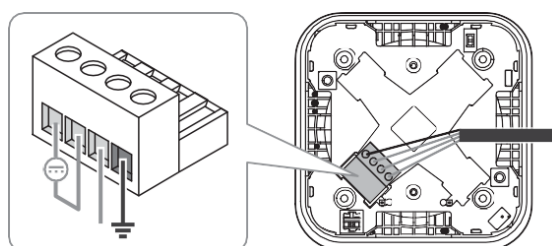

Inhibit Level Selection

Use the inhibit switch to set the level of current which is required when inhibit is active.

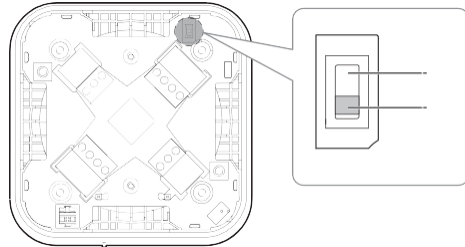

- 1) With this switch in the upper position, a current of 4 mA is output in inhibit mode. In the case of oxygen versions only, 17.4 mA is used.
- 2) With this switch in the lower position, a current of 2 mA is output in inhibit mode on all versions.

Current Source/Sink Selection

⚠ CAUTION

Always disconnect power before changing the position of this switch. Failure to do so may result in damage to the Sensepoint XCL detector.

Use the current source/sink switch to choose between source mode and sink mode.

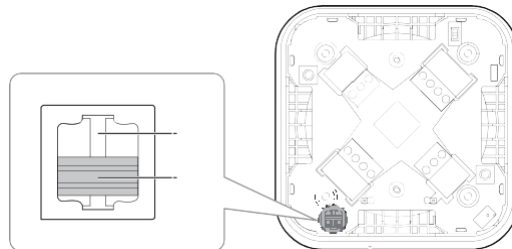

- 1) Detector sink mode: With this switch in the upper position, the analog output drives current through the controller sensing circuit.
- 2) Detector source mode: With this switch in the lower position, the analog output draws current through the controller sensing circuit.

NOTE

The load resistance of the controller must be between 33 Ω and 250 Ω . When the mA output is not being used, a 33 Ω , 0.125 W load resistor should be connected between terminal 3 (4–20 mA) and terminal 2 (0 V) for source mode or terminal 1 (+24 V DC) for sink mode. Failure to do so will cause the unit to enter a fault condition.

NOTE

When operating the detector from an AC power supply, the current loop (mA) wiring should be connected between terminals 3 (4-20 mA) and 4 (COM).

Detector Source Mode with DC Power

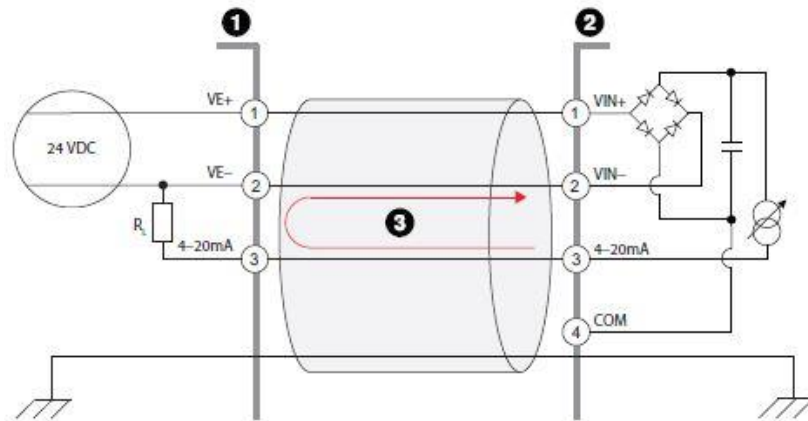

- 1) System controller
- 3) Current flow

- 2) Sensepoint XCL detector

Detector Sink Mode with DC Power

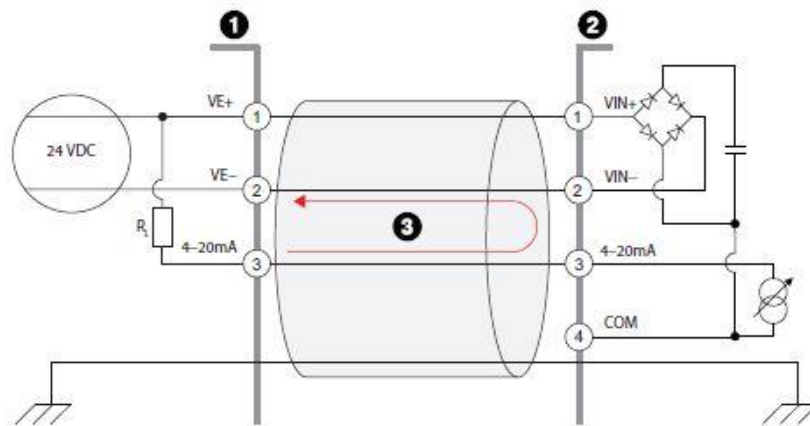

- 1) System controller
- 3) Current flow

- 2) Sensepoint XCL detector

Detector Source Mode with AC Power

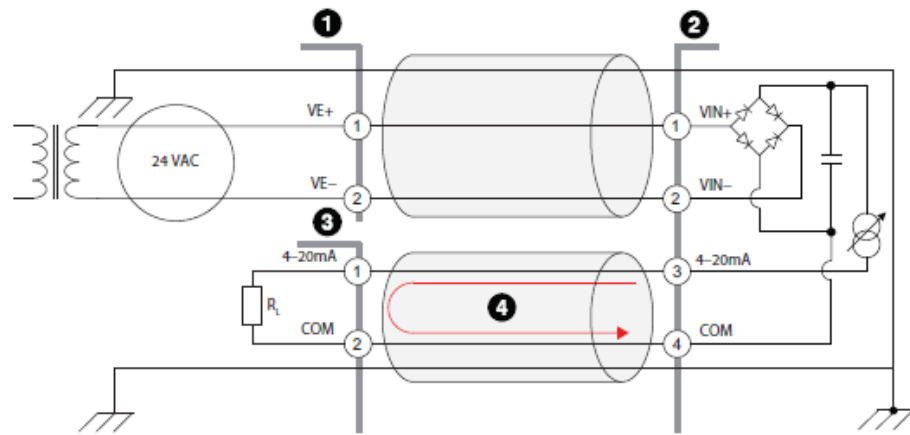

- | | |
|--------------------------|----------------------------|
| 1) External power supply | 2) Sensepoint XCL detector |
| 3) System controller | 4) Current flow |

Detector Sink Mode with AC Power

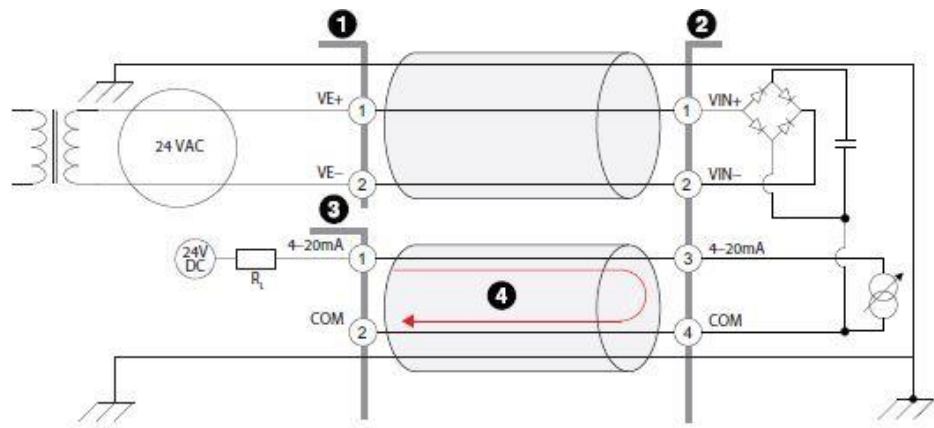

- | | |
|--------------------------|----------------------------|
| 1) External power supply | 2) Sensepoint XCL detector |
| 3) System controller | 4) Current flow |

2.6 Wiring of Modbus Output Versions

Modbus Connection

For Modbus versions, up to 32 Sensepoint XCL detectors can be connected in a daisy chain arrangement as shown in the diagram below.

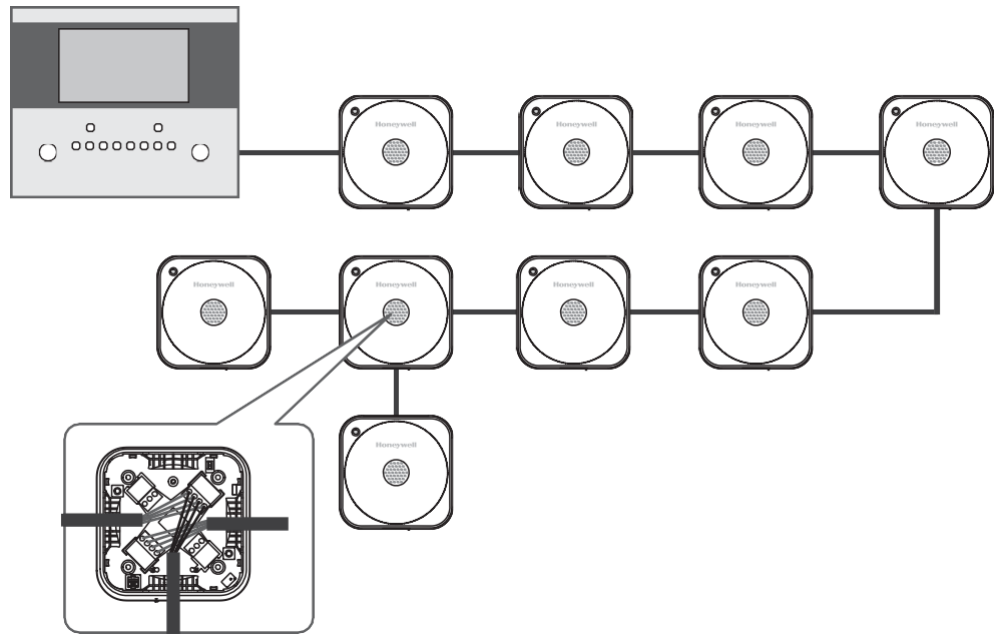

NOTE

Where possible, spur or ‘T’ connections should be avoided. Always keep the spur connection as short as possible.

Cable Specification for Modbus Connection

Type	Cable Spec	Max Length
Modbus	0.5 mm ² to 2.5 mm ² twist pair shield cable	1000 m

Terminal Resistor

Connect a 120Ω, 0.25 W terminal resistor between the A and B terminals at the end of the line.

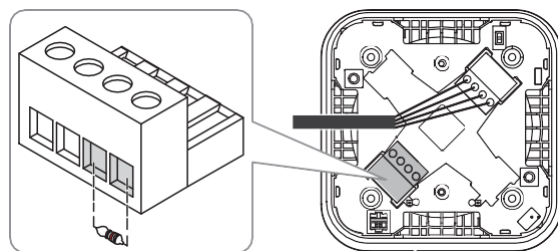

2.7 Securing the Back Box to a Wall

⚠ CAUTION

Before starting installation, make sure that the system controller or external power source is switched off

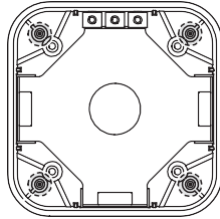

1. There are four screw positions in the rear of the back box for mounting purposes. Punch the required screw positions or drill using a 4 mm drill.

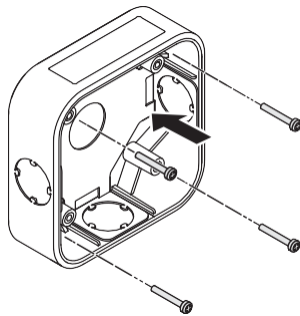

2. Secure the back box in its mounting position with suitable fixings appropriate to the mounting surface. Do not over-tighten.

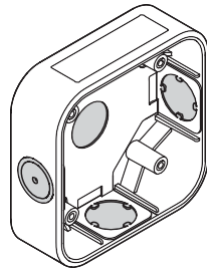

3. There are four cable entry knock-outs on three sides of and on the rear face of the back box. Drill or punch the entries as required.

2.8 Cable Connections

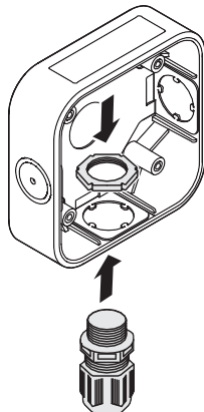

1. Fit suitable cable glands appropriate to the application and type of cable being utilized to the opened cable entries.

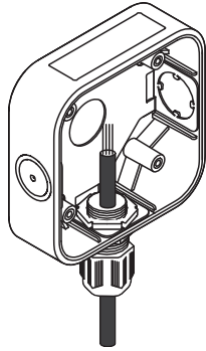

2. Feed the cable through the cable gland.

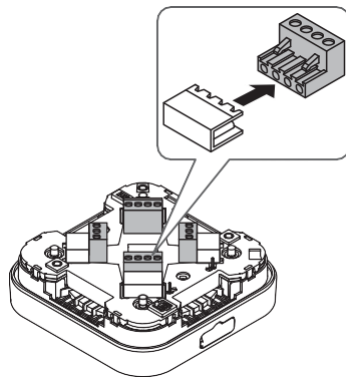

3. Turn over the detector module and locate the terminal blocks on the back. Remove the terminal blocks by pulling them toward the center of the module.

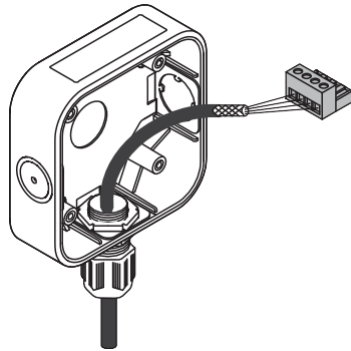

4. Connect the cable to the appropriate terminal block, referring to the relevant wiring diagram. Strip and insert the end of each wire into the corresponding terminal hole. Using a flat-blade terminal screwdriver, tighten the terminal screw until the wire is secured. Use a ferrule on the wire where necessary.

⚠ CAUTION

Do not over-tighten the terminal screw.

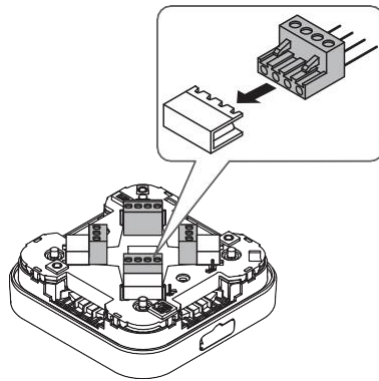

5. Replace the terminal blocks in their correct positions.

2.9 Ground Connections

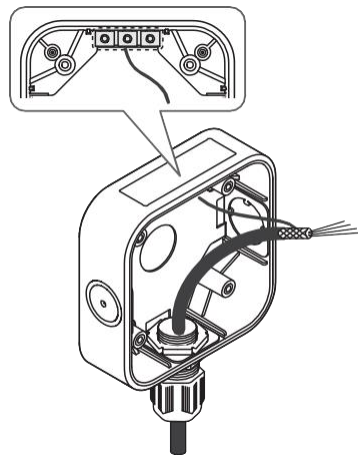

Effective grounding is crucial to ensure stable Modbus communications and to limit the effects of radio frequency interference. Ground points are provided inside the back box. In order to prevent false readings or alarms as a result of ground loops, ensure that the shield of all cables are grounded at a single point, preferably at the controller. Consideration should also be given to how conduit, glands and the internal earth plate are also grounded.

NOTE

Any earth regime must avoid earth loops.

2.10 Securing the Detector Module to the Back Box

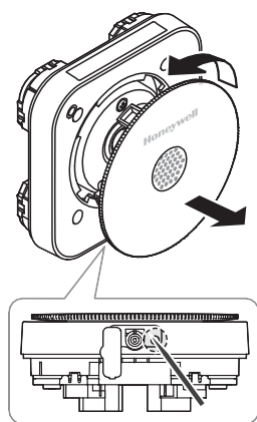

1. Remove the front cover from the detector module to expose the four retaining screws as follows:
 - a) Pull the flap on the bottom side to expose the remote gassing port and front cover locking feature.
 - b) To unlock the front cover, insert a thin, straight tool, such as a small screwdriver, into the hole to the right of the remote gassing port.
 - c) Apply slight pressure to the tool and at the same time turn the cover counterclockwise until it stops. Lift the front cover clear of the module.

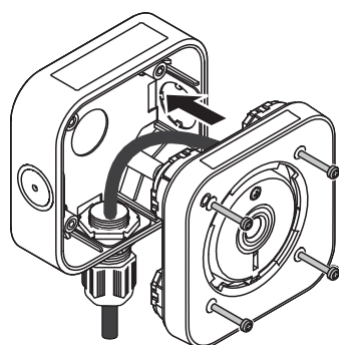

2. Position the detector module onto the back box ensuring that the status indicator is in the top left-hand corner when viewed from the front. Tighten the four retaining screws using a No. 2 Phillips screwdriver to secure.

CAUTION

Do not over-tighten the screws. If required, the current sink/source selection switch can be set at this point.

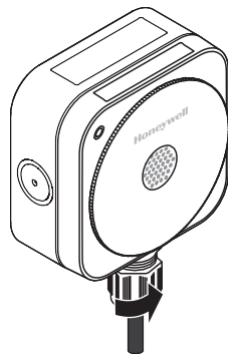

3. Where used, tighten the sealing nut of the cable gland to secure the cable.

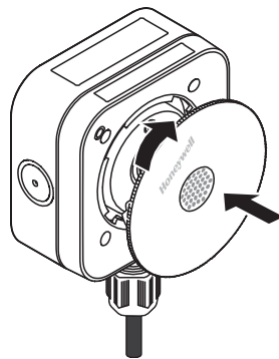

4. Replace the front cover. Place the front cover into the detector module in the position shown and rotate it clockwise until it locks into position.

2.11 Remote Gassing Connection

NOTE

Use the remote gassing connection for bump test only. Perform calibrations using the calibration cap accessory.

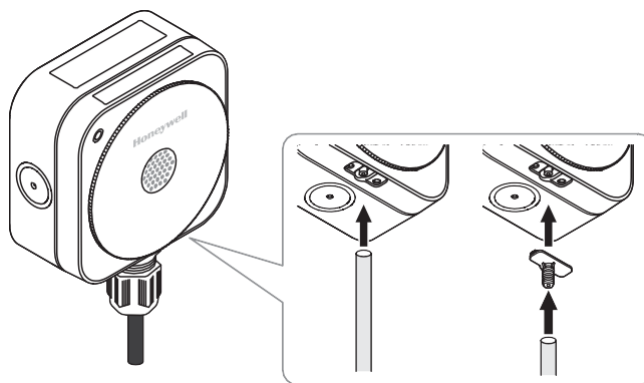

If the gas detector is installed in a difficult-to-access location, such as overhead on a ceiling, the remote gassing connection can be used to apply a test gas from a convenient location. Connect a tube appropriate for the type of gas being detected to the gas detector for bump test.

- For a temporary connection, open the flap on the bottom side and

connect suitable tubing to the remote gassing port.

- For a permanent connection, remove the flap, clip in the tube connector accessory to the remote gassing port, and then connect a tube to the tube connector. Secure the tube using a cable tie or small jubilee clip, taking care not to over-tighten it.

Chapter 3

Commissioning

NOTE

The Sensepoint XCL gas detector is supplied from the factory pre-calibrated. However, it is strongly recommended that the detector response is checked and if necessary, re-calibrated before placing it into service. Refer to Calibration on page 36 for details on the correct calibration procedure.

3.1 Commissioning the Detector

The following procedure should be followed carefully and only be performed by suitably-trained personnel.

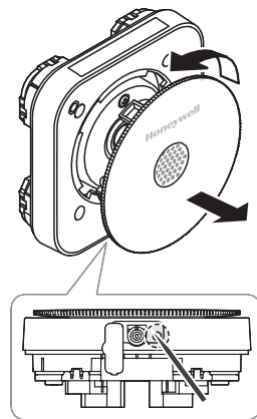

1. Remove the front cover.
 - a) Pull the flap on the bottom side to open it.
 - b) Insert a thin, straight tool, such as a small screwdriver, into the hole to the right of the remote gassing port.
 - c) Apply slight pressure to the tool, turn the cover counterclockwise until it stops. Lift the cover clear of the electronics module.

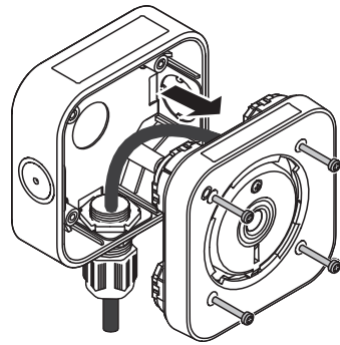

2. Remove the detector module of Sensepoint XCL.

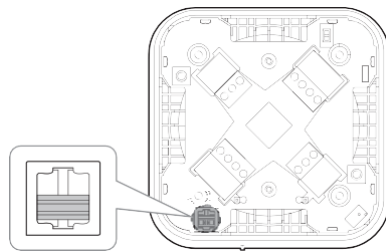

3. Configure the sink/source mode of the detector. Refer to Current Source/Sink Selection on page 18 on details of how to do this.

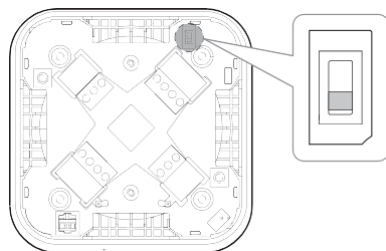

4. Configure the required inhibit level of the detector. Refer to section Inhibit Level Selection on page 18 on details of how to do this.
5. Check that all electrical connections are terminated correctly according to the connector terminal assignments shown on 8 and 9.

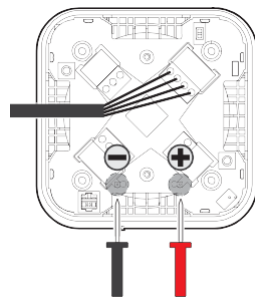

6. Switch on the power supply to the Sensepoint XCL.
 - a) For DC operation, use a voltmeter set to measure DC voltage at the detector. Check that the power supply voltage between terminals 1 (+V) and 2 (0 V) is between 9 V DC and 32 V DC for Modbus versions and 11 V DC and 32 V DC for analog versions.
 - b) For AC operation, use a voltmeter set to measure AC voltage to check that the power supply voltage between terminals 1 and 2 is between 20 V AC and 27 V AC.

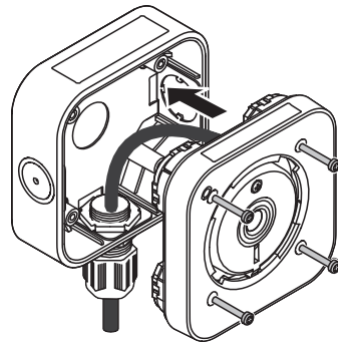

7. Remove power and refit the detector module to the back box.

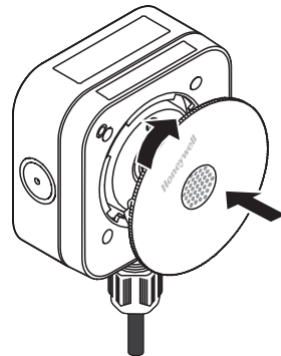

8. Refit the front cover.
9. Apply power. The Sensepoint XCL will enter a warm-up mode during which time the status indicator will be steady yellow and the output (mA version) will be held in an inhibited state.
10. After the warm-up has been completed, the Sensepoint XCL will enter its normal operating state.

3.2 Status Indicator







There is a status indicator on the face of the gas detector. The operating state of the detector is indicated by one of four colors, either steady or flashing.



- **Normal:** The indicator is on steady green when the concentration of the target gas is within normal range.

NOTE

Using the mobile Sensepoint app, you can change how the green indicator behaves during normal operation. Select between steady green (default setting), confidence flash every 20 seconds or off.

-  **Warning:** The indicator alternatively flashes green and yellow when the gas detector is in a warning state.
-  **Fault:** The indicator flashes yellow when the gas detector is in a fault state.
-  **Inhibited:** The indicator is on steady yellow when the user has placed the detector into the inhibit state for maintenance or repair.
-  **Alarm:** The indicator flashes red when the gas concentration is beyond the alarm-level threshold.
-  **Out-of-range alarm:** The indicator rapidly flashes red when the gas concentration is beyond the full scale deflection of the detector.
-  **Bluetooth pairing:** The indicator flashes blue when Bluetooth pairing between the gas detector and an Android device is in progress.
-  **Bluetooth connected:** The indicator is on steady blue when a Bluetooth connection is established and the detector is in a normal condition.

3.3 Target Gas Selection (flammable catalytic versions only)

The target flammable gas of the Sensepoint XCL can be changed using the Sensepoint App and the user can select from a range of flammable gases. Please refer to the Sensepoint App manual for full details on how to do this.

NOTE

Before changing the target gas a zero calibration should be performed in clean air.

The Sensepoint XCL gas detector operates on a Star Rating system where gases are grouped depending on the response of the sensor to them. The higher the star rating, the more responsive the sensor is to the gas. The table below shows the Star Ratings for a range of gases.

Gas	Equivalent Star Rating
Acetone	3*
Ammonia	7*
Benzene	3*
Butanone	3*
Butane	4*
Butyl acetate	1*
Butyl acrylate	1*
Cyclohexane	2*
Cyclohexanone	<1*
Diethyl ether	3*
Ethane	5*
Ethanol	4*
Ethyl acetate	3*
Ethylene	5*
Heptane	3*
Hexane	3*
Hydrogen	7*
Methane	6*
Methanol	5*
MIBK	3*
Octane	3*
Pentane	3*
Propane	4*
Propan-2-ol	3*
Styrene	2*
Tetrahydrofuran	4*
Toluene	3*
Triethylamine	3*
Xylene	2*

For maximum accuracy, the Sensepoint XCL catalytic sensor should be calibrated using a known calibration gas (with an air balance) equal to 50% of the actual target gas intended to be monitored.

Chapter 4

Maintenance

4.1 Using the Control Buttons

It is possible to perform basic maintenance functions on the Sensepoint XCL gas detector without the use of the mobile app. This is achieved through the use of two control buttons inside the detector. Familiarize yourself fully on the operation of these buttons before attempting to use them.

NOTE

Make sure that the inhibit level is set to the desired level. See Inhibit Level Selection on page 18.

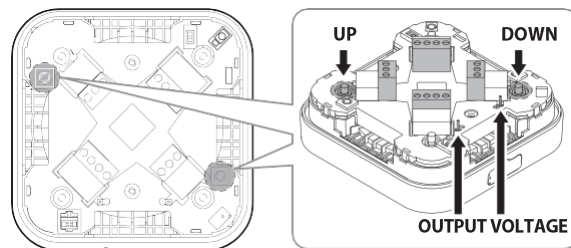

To inhibit the detector output: Press and hold the UP button for 2 seconds.

To increase the output voltage: Briefly press the UP button. Pressing once increases by 0.01 V. To increase by 0.1 V, press and hold the button.

To decrease the output voltage: Briefly press the DOWN button. Pressing once decreases by 0.01 V. To decrease by 0.1 V, press and hold the button.

To move to the next stage: Press and hold the UP button for 2 seconds. If a change has been made, it is saved automatically before proceeding to the next stage.

To escape and discard all changes: This escape function can be used at any time during the procedures detailed in the following sections. Press and hold the DOWN button for 5 seconds.

4.2 Maintenance Status Indicator

There is another indicator on the rear of the detector module for easier maintenance. When performing maintenance, such as calibration or sensor replacement, using the control buttons, refer to the indicator to determine the status of the detector.

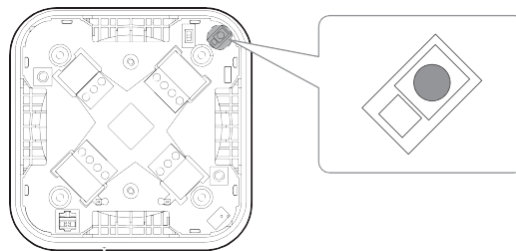

Inhibit mode

While in inhibit mode, the indicator is on steady yellow ●.

Sensor replacement mode

While in sensor replacement mode, the indicator slowly flashes yellow ☀. When in warm-up, the indicator is on steady yellow ●.

Zero calibration

During zero calibration, the indicator flashes long yellow ☀ followed by two short yellow flashes ☀. First short yellow flash indicates zero status and second flash indicates span status. The indicator flashes long yellow ☀ followed by short green flash 🌿 and short yellow flash ☀ when the zero calibration is successfully completed, but flashes long yellow ☀ followed by short red flash 🌶 and short yellow flash ☀ if it fails.

Span calibration

During span calibration, the indicator flashes yellow ☀. The indicator flashes green 🌿 with two short pauses when the span calibration is successfully completed, but flashes red 🌶 with two short pauses if it fails.

Calibration gas purge

While the calibration gas is purged, the indicator is on steady yellow ● .

Cancel

When a task is cancelled, the indicator flashes yellow ☀ with three short pauses.

4.3 Calibration Cap

The following table shows the recommended flow rate and stabilization time for each of the gas types.

Gas Type	Recommended Flow Rate	Recommended Stabilization Time
CO	300 cc/min	3 min
H ₂ S	300 cc/min	3 min
O ₂	300 cc/min	3 min
CH ₄	300 cc/min	3 min
NO ₂	300 cc/min	5 min
H ₂	300 cc/min	5 min
NH ₃	300 cc/min	5 min
CO ₂ (ppm, %vol)	500cc/min	3 min

NOTE

Always use a flow regulator, tubing and fittings appropriate for the type of gas being applied.

Use remote gassing connection for bump test only. Perform calibrations using the calibration cap accessory.

A calibration cap accessory is available for the application of reference gas for the purpose of calibration. To fit the calibration cap, follow the steps below.

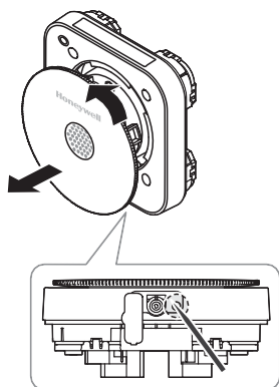

1. Remove the front cover.
 - a) Pull the flap on the bottom side to open it.
 - b) Insert a thin, straight tool, such as a small screwdriver, into the hole to the right of the remote gassing port.
 - c) Apply slight pressure to the tool, turn the cover counterclockwise until it stops. Lift the cover clear of the electronics module.

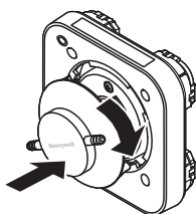

2. Attach the calibration cap to the detector. Insert the calibration cap into the front of the detector as shown, and turn it clockwise until it locks into place.

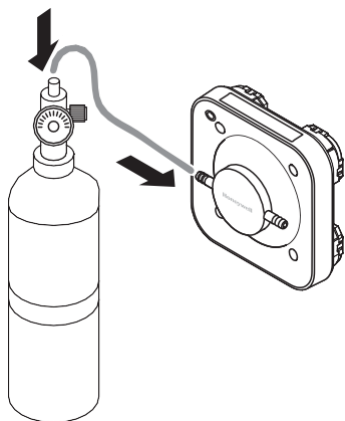

3. Connect a tube from a cylinder of calibration gas to either of the cap's gassing ports.

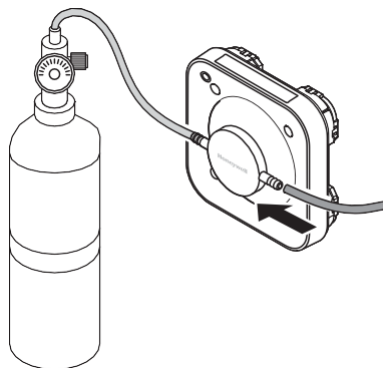

4. Connect another tube to the other gassing port, and place the end of this tube in a position so that gas can exhaust safely away from the work area and other personnel.

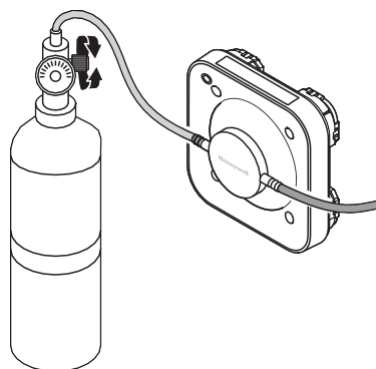

5. Refer to the regulator manufacturer for instructions on how to start and stop the gas flow from the cylinder.

⚠ CAUTION

Always use a gas cylinder that is within its expiration date.

4.4 Calibration

NOTE

On versions that feature the Bluetooth® link, it is preferential to use a smartphone running the app to perform maintenance tasks.

This section describes how to perform a calibration using the control buttons and the internal maintenance status indicator. Before starting calibration, make sure that the gas detector is powered on.

1. Activate inhibit mode by pressing and holding the UP button for 2 seconds. Make sure that the yellow indicator is on.
2. Connect the positive probe of a voltmeter to the positive terminal, and connect the negative probe to the negative terminal of the output voltage monitor.

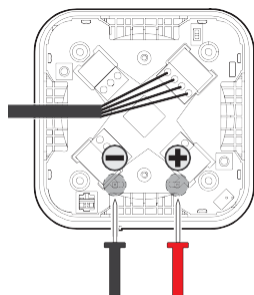

3. Move to the next stage perform a zero calibration.
 - a) Move to the next step by holding the UP button for 2 seconds.
 - b) If there is any doubt of the quality of the atmosphere, connect a cylinder of fresh air to the detector using the installed tube or

the calibration cap. For details about how to use a calibration cap, see Calibration Cap on page 34.

- c) Apply fresh air to the detector, and wait for a few minutes until the reading is stable.
 - d) Using the UP and DOWN buttons, adjust the output voltage so that the voltmeter is reading slightly above zero, and then decrease the reading slowly so that it reads zero.
 - e) When the output voltage is adjusted close to zero, accept the zero calibration by holding UP button for 2 seconds.
4. If a span calibration is required, after successful zero calibration it will move to span calibration automatically. If a span calibration is not required, exit from calibration by holding DOWN button for 5 seconds. This will cancel a span calibration while zero calibration result sustains.
- a) Move to the next step by holding the UP button for 2 seconds.
 - b) Connect a cylinder of span gas to the detector. Where the greatest accuracy is required, the cylinder concentration should be usually around the alarm set point or 50% of the range of the detector.
 - c) Apply the span gas to the detector, and wait for a few minutes until the reading is stable.
 - d) Using the UP and DOWN buttons, adjust the output voltage until it reaches the target value. Use the formula below to calculate what the correct voltage should be.
- $$V_{\text{out}} = \text{Gas concentration} \div \text{detector range}$$
- For example, if you are applying 45% LEL gas with a 100% LEL detector range, you would need to adjust the voltage output so that the reading on the voltmeter shows:
- $$45 \div 100 = 0.45 \text{ V}$$
- e) When the output voltage is adjusted close to target gas concentration, accept the span calibration by holding UP button for 2 seconds.
5. Purge the gas sensor.
- a) Move to the next step by holding the UP button for 2 seconds.
 - b) Remove the span gas from the detector.

- c) Make sure that the reading voltage out returns to zero. If there is any doubt that the detector is not in fresh air, apply cylinder air. Otherwise, an alarm may occur.
6. Use the cancel function to return to normal monitoring mode.

If repeated calibration attempts continue to fail, replace the gas sensor with a new one, and then try again. See **Replacing the Sensor** on page 39.

4.5 Bump Test

This section describes how to perform a bump test. For details about the mobile app, see **Mobile App** on page 41.

Bump testing is the process of exposing the gas sensor to a known concentration of reference gas that is greater than the low alarm threshold in order to verify the proper operation of the gas detector.

1. Connect your smartphone with the target gas detector via Bluetooth.
2. Place the detector in inhibit mode by using the inhibit control on the mobile app.
3. Connect a cylinder of reference gas to the target detector using a suitable tube connected to the gassing port or the calibration cap. For details about how to use a calibration cap, see **Calibration Cap** on page 34.
4. Connect your smartphone with the target detector via Bluetooth.
5. Apply the bump test gas to the detector.

NOTE

For CO versions operating in UL 2075 alarm mode, apply 100 ppm of carbon monoxide at a flow rate of 300 mL/min for 3 minutes.

6. If the detector fails the bump test, check and if necessary, calibrate the detector.

NOTE

Perform a bump test at least twice a year.

4.6 Replacing the Sensor

WARNING

Use only genuine replacement sensors specifically for use with Sensepoint XCL. Attempting to use non-genuine sensors could result in malfunction of the product.

CAUTION

Do not replace the sensor without first a) removing power to the Sensepoint XCL or b) placing the sensor into the sensor maintenance mode.

Connect your smartphone to the Sensepoint XCL via Bluetooth. Tap the Maintenance button and select Change Sensor. Follow the on-screen instructions.

In cases where a smartphone running the mobile app is not available, follow the steps below:

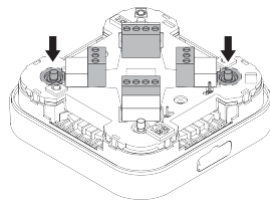

1. Press and hold the UP button for 10 seconds to switch to sensor replacement mode. In this mode, the detector output is inhibited and the sensor circuits are internally isolated.

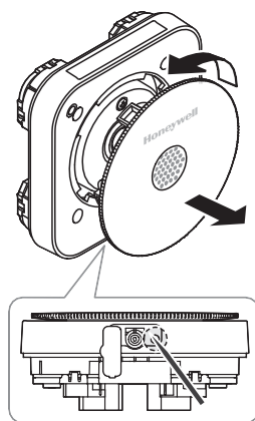

2. Remove the front cover to expose the sensor cover.
 - a) Pull the flap on the bottom side to open it.
 - b) To unlock the front cover, insert a thin, straight tool, such as a small screwdriver, into the hole beside the remote gassing port.
 - c) Apply slight pressure to the tool, turn the cover counterclockwise until it stops. Lift the front cover free from the sensor module.

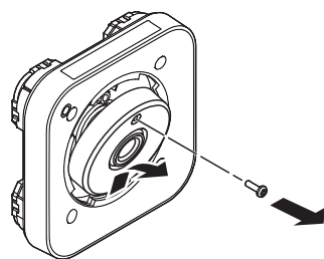

3. Remove the sensor cover.
 - a) Loosen the screw on the top of the sensor cover.
 - b) Holding the screw, tilt it downwards from the upper edge of the cover.

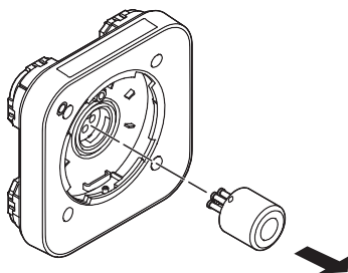

4. Pull out the gas sensor to remove it.
5. Ensuring that the sensor pins are correctly aligned, insert a new sensor into the sensor socket.

⚠ CAUTION

Do not force the sensor into the socket, otherwise it may be damaged.

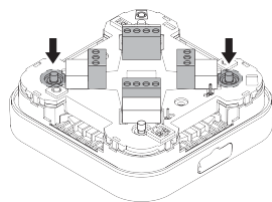

6. Press and hold the UP button for 2 seconds to activate warm-up mode. In this mode, the output continues to be held in its inhibit state.

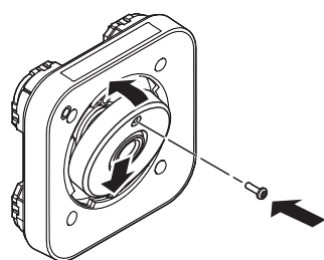

7. Replace the sensor cover and secure with the screw, taking care not to over-tighten it.
8. Switch to normal monitoring mode by holding the DOWN button for 5 seconds.
9. Perform a calibration in accordance with Calibration on page 36.

4.7 Resetting Alarms and Faults

When there is latched gas alarm or faults, reset them by pressing the UP or DOWN button shortly. This will reset latched alarms and faults, and initiate a self diagnostics to make sure there is no warning or fault in the detector.

Chapter 5

Mobile App

Use the Sensepoint app to allow your smart device to connect to Sensepoint XCL. This mobile app makes it much easier to configure and maintain Sensepoint XCL detectors. The general procedure of using the mobile app is as follows:

1. Download **Sensepoint App** from Google Play Store. Install and launch the app.
2. Create and register a user account, and log on with the created account information.
3. To associate with one or more gas detectors, scan the QR code on the sheet included in the box or enter its Activation Key and Device Serial Number.
4. Complete the installation of the detectors.
5. On the app's home screen, tap **DETECTORS** to scan for available detectors.
6. Select a detector from the detector list to pair with.
7. Look for the detector whose Status Indicator is flashing blue.
8. Tap **Confirm Detector** to pair with that detector. Otherwise, tap **Return to list** to select one of the others.
9. To connect to detectors that are not added to your user account, you will need registration sheet containing the device QR code. This can also be found on a label on the rear of the electronics module.

When a Bluetooth connection is established, the detector's reading is displayed on the app interface with the gas type.

For details how to use the mobile app, refer to the Sensepoint app manual.

Chapter 6

Security Guide

Adhere to the following points:

1. Keep the device's "Registration sheet", "QR-CODE" and "Activation-key" safely to prevent any unauthorized access;
2. Make sure that only authorized reliable people who get the appropriate training can assess to the device;
3. The confidential information can be revealed by the 3rd party's keyboard intentionally. Honeywell does NOT recommend using the 3rd party's keyboard;
4. Set the password of user account as the followings:
 - Use (Set) the strong password that is a combination of numbers, characters, and a special character;
 - Do not use the same character more than 4 times in the password;
 - Do not use the password that has been used before;
 - Set the new password within 90 days;
 - Do not use the passwords such as consecutive numbers/characters, birthday, phone number, simple word and name that everyone can figure out easily.

Appendix A

Detector Parameters

Non-Bluetooth Versions (not available in all countries)

Gas	Detector Type	User Selectable Range	Default Range	User Selectable Cal Gas Range	Default Cal Point	Response Time t90 (s)	Resolution	Accuracy (Reading or % of applied gas which is the greater)
Oxygen	SPLLO1...	Fixed, 25.0% vol	25.0% vol	N/A	N/A	< 30	N/A	<±0.5 %vol
Flammable(CAT)	SPLLF6...	Fixed, 100% LEL	100% LEL	N/A	N/A	< 30	N/A	< ±3%LEL
Carbon Monoxide (low range)	SPLLC1...	Fixed, 100 ppm	100 ppm	N/A	N/A	< 30	N/A	< ±2 ppm or ±10%
Carbon Monoxide (high range)	SPLLC2...	Fixed, 300 ppm	300 ppm	N/A	N/A	< 30	N/A	< ±2 ppm or ±10%
Hydrogen Sulfide (low range)	SPL LH1...	Fixed, 50.0 ppm	50.0 ppm	N/A	N/A	< 30	N/A	< ±0.3 ppm or ±10%
Hydrogen Sulfide (high range)	SPL LH2...	Fixed, 100 ppm	100 ppm	N/A	N/A	< 30	N/A	< ±5 ppm or ±10%
Hydrogen	SPL LG1...	Fixed, 1000 ppm	1000 ppm	N/A	N/A	< 90	N/A	< ±15 ppm or ±20%
Nitrogen Dioxide	SPL LN1...	Fixed, 20.0 ppm	20.0 ppm	N/A	N/A	< 30	N/A	< ±0.2 ppm or ±20%
Carbon Dioxide (ppm)	SPL LB3...	Fixed, 5000 ppm	5000 ppm	N/A	N/A	< 30	N/A	< ±30 ppm or ±20%
Carbon Dioxide (%vol)	SPL LB4...	Fixed, 5.0% vol	5.0% vol	N/A	N/A	< 30	N/A	< ±0.2 %vol or ±20%
Ammonia	SPL LA1...	Fixed, 100 ppm	100 ppm	N/A	N/A	< 180	N/A	< ±4 ppm ±20%

Gas	Sensor Operating Temperature		Default Alarm Points & Types						LAL	LDL
	Min	Max	A1	Default A1 Type	A1 Options	A2	Default A2 Type	A2 Options		
Oxygen	-20 °C	50 °C	23.5% vol	Rising	N/A	19.5% vol	Falling	N/A	N/A	20.6 to 21.2% vol 0 to 3.0% vol
Flammable(CAT)	-20 °C	50 °C	20% LEL	Rising	N/A	50% LEL	Rising	N/A	N/A	6% LEL
Carbon Monoxide (low range)	-20 °C	50 °C	25 ppm	Rising	N/A	40 ppm	Rising	N/A	N/A	10 ppm
Carbon Monoxide (high range)	-20 °C	50 °C	30 ppm	Rising	N/A	100 ppm	Rising	N/A	N/A	10 ppm
Hydrogen Sulfide (low range)	-20 °C	50 °C	10 ppm	Rising	N/A	20 ppm	Rising	N/A	N/A	0.8 ppm
Hydrogen Sulfide (high range)	-20 °C	50 °C	10 ppm	Rising	N/A	20 ppm	Rising	N/A	N/A	1 ppm
Hydrogen	-20 °C	50 °C	200 ppm	Rising	N/A	400 ppm	Rising	N/A	N/A	30 ppm
Nitrogen Dioxide	-20 °C	50 °C	2.0 ppm	Rising	N/A	5.0 ppm	Rising	N/A	N/A	0.3 ppm
Carbon Dioxide (ppm)	-20 °C	50 °C	1500 ppm	Rising	N/A	3000 ppm	Rising	N/A	N/A	300 ppm
Carbon Dioxide (%vol)	-20 °C	50 °C	0.4% vol	Rising	N/A	0.8% vol	Rising	N/A	N/A	0.1% vol
Ammonia	-20 °C	40 °C	25 ppm	Rising	N/A	50 ppm	Rising	N/A	N/A	6 ppm

Bluetooth Versions

Gas	Detector Type	User Selectable Range	Default Range	User Selectable Cal Gas Range	Default Cal Point	Response Time		Accuracy (Reading or % of applied gas which is the greater)
						t90 (s)	Resolution	
Oxygen	SPLCO1...	Fixed, 25.0%vol	25.0% vol		20.9% vol	< 30	0.1% vol	< ±0.5 %vol
Flammable (CAT)	SPLCF6...	20 to 100% LEL	100% LEL		50% LEL	< 30	1% LEL	< ±3 %LEL or ±10%
Carbon Monoxide	SPLCC1...	50 to 1000 ppm	300 ppm	20 to 70% of selected fullscale	100 ppm	< 30	1 ppm	< ±2 ppm or ±10%
Hydrogen Sulfide (low range)	SPLCH1...	10.0 to 50.0 ppm	50.0 ppm	range (except oxygen)	25 ppm	< 30	0.1 ppm	< ±0.3 ppm or ±10%
Hydrogen Sulfide (high range)	SPLCH2...	50 to 200 ppm	100 ppm		25 ppm	< 30	1 ppm	< ±5 ppm or ±10%
Hydrogen	SPLCG1...	1000 ppm only	1000 ppm		500 ppm	< 90	1 ppm	< ±15 ppm or ±20%
Nitrogen Dioxide	SPLCN1...	5.0 to 50.0 ppm	20.0 ppm		5 ppm	< 30	0.1 ppm	< ±0.2 ppm or ±20%
Ammonia	SPLCA1...	50 to 200 ppm	100 ppm		50 ppm	< 180	1 ppm	< ±4 ppm ±20%
Carbon Dioxide (ppm)	SPLCB3...	1000 to 5000 ppm	5000 ppm		2500 ppm	< 30	10 ppm	< ± 30 ppm or ± 20%
Carbon Dioxide (%vol)	SPLCB4...	1.0 to 5.0% vol	5.0% vol		2.5% vol	< 30	0.1% vol	< ± 0.2 %vol or ± 20%

Gas	Sensor Operating Temperature		Default Alarm Points & Types						LAL	LDL
	Min	Max	A1	Default A1 Type	A1 Options	A2	Default A2 Type	A2 Options		
Oxygen	-20°C	50°C	23.5%vol	Rising	Rising/Disabled	19.5%vol	Falling	Falling/Disabled	5.0% vol	20.6 to 21.2% vol 0 to 3.0% vol
Flammable (CAT)	-20°C	50°C	20% LEL	Rising	Rising/Disabled	50% LEL	Rising	Rising/Disabled	10% LEL	6% LEL
Carbon Monoxide	-20°C	50°C	30 ppm	Rising	Rising/Disabled	100 ppm	Rising	Rising/Disabled	15 ppm	10 ppm
Hydrogen Sulfide (low range)	-20°C	50°C	10 ppm	Rising	Rising/Disabled	20 ppm	Rising	Rising/Disabled	1.0 ppm	0.8 ppm
Hydrogen Sulfide (high range)	-20°C	50°C	10 ppm	Rising	Rising/Disabled	20 ppm	Rising	Rising/Disabled	5 ppm	1 ppm
Hydrogen	-20°C	50°C	200 ppm	Rising	Rising/Disabled	400 ppm	Rising	Rising/Disabled	100 ppm	30 ppm
Nitrogen Dioxide	-20°C	50°C	0.7 ppm	Rising	Rising/Disabled	2.0 ppm	Rising	Rising/Disabled	0.6 ppm	0.3 ppm
Ammonia	-20°C	°40°C	20 ppm	Rising	Rising/Disabled	50 ppm	Rising	Rising/Disabled	20 ppm	6 ppm
Carbon Dioxide (ppm)	-20°C	50°C	1500 ppm	Rising	Rising/Disabled	3000 ppm	Rising	Rising/Disabled	500 ppm	300 ppm
Carbon Dioxide (%vol)	-20°C	50°C	0.4% vol	Rising	Rising/Disabled	0.8% vol	Rising	Rising/Disabled	0.2% vol	0.1% vol

NOTE

Performance figures are based on the following:

- The humidity of the test gas is 50% RH. The performance values given are valid between 10% and 90% RH.
- Are measured using test units calibrated at 50% of full scale,
- Measurements are based on gas being applied using the calibration adapter at a rate of 300 ml/min for a period of 3 minutes (oxygen, flammable (CAT), carbon monoxide, hydrogen sulfide) and 5 minutes (hydrogen, nitrogen dioxide and ammonia), at a rate of 500ml/min for a period of 3 minutes (carbon dioxide).
- Response time (T90) may increase when operating in lower temperature conditions.
- With the exception of oxygen and flammable (CAT), the accuracy for all sensors is $\pm 30\%$. The accuracy of oxygen versions over is $\pm 0.9\%$ vol. The accuracy of the flammable (CAT) versions is $\pm 5\%$ LEL. All figures are valid over the temperature range $-20\text{ }^{\circ}\text{C}$ to $50\text{ }^{\circ}\text{C}$.
- Operating flammable CAT and O_2 , zero drift may be experienced in high humidity environments. Recalibrate the unit in the environment in which it is going to be used.
- Maximum accuracy of the flammable CAT version will be achieved after the unit has been operating for 48 hours.
- For H_2 version, it is recommended to recalibrate the detector when used in low temperature environments ($< -10\text{ }^{\circ}\text{C}$).

Appendix B

Troubleshooting

B.1 Warning

Description	Troubleshooting
Warning 1 Calibration Overdue	Calibrate the unit
Warning 3 BLE failure (BLE version only)	Power-cycle the unit. If same warning occurs again, contact manufacturer
Warning 4 Time/date not set (RTC not set) / RTC reset abnormally	Configure unit time. If same warning occurs again, contact manufacturer
Warning 5 Log memory corrupted (CRC not matched)	Power-cycle the unit. Event log might be lost.
Warning 6 Certificate is corrupted or missing certificate	Contact manufacturer
Warning 7 Over-range warning	Calibrate the unit.
Warning 8 Under-range warning	Calibrate the unit.

B.2 Fault

Description	Troubleshooting
Fault 1 Internal communication failure	Power-cycle the unit. If same fault occurs again, contact manufacturer
Fault 2 Cell failure	Check the sensor connection. If same fault occurs again, replace sensor
Fault 3 Cell is producing a negative reading	Calibrate the unit
Fault 4 EEPROM is corrupted	Reconfigure the unit by using mobile app. If same fault occurs again, contact manufacturer
Fault 5 MCU operating voltage failure	Power-cycle the unit. If same fault occurs again, contact manufacturer
Fault 6 RAM read/write fault	Power-cycle the unit. If same fault occurs again, contact manufacturer
Fault 7 Flash memory corrupted	Reconfigure the unit by using mobile app
Fault 8 Code memory failure	Power-cycle the unit. If same fault occurs again, contact manufacturer
Fault 9 mA output failure (mA output version only)	Check whether loopback resistor is connected correctly
Fault 10 Supplied voltage failure	Power-cycle the unit. If same fault occurs again, contact manufacturer
Fault 11 Internal HW Fault	Power-cycle the unit. If same fault occurs again, contact manufacturer
Fault 12 Internal SW Fault	Power-cycle the unit. If same fault occurs again, contact manufacturer
Fault 13 Calibration Overdue	Calibrate the unit.

Appendix C

Ordering Information

C.1 Detectors

Part number	Description
SPLLO1XAXCXNZZ	Sensepoint XCL Transmitter, Compliance, Safe Area, IP65, O ₂ , 4–20 mA, Charcoal
SPLLF6XAXCXNZZ	Sensepoint XCL Transmitter, Compliance, Safe Area, IP65, CH ₄ (CAT), 4–20 mA, Charcoal
SPLLC1XAXCXNZZ	Sensepoint XCL Transmitter, Compliance, Safe Area, IP65, CO (L), 4–20 mA, Charcoal
SPLLC2XAXCXNZZ	Sensepoint XCL Transmitter, Compliance, Safe Area, IP65, CO (H), 4–20 mA, Charcoal
SPL LH1XAXCXNZZ	Sensepoint XCL Transmitter, Compliance, Safe Area, IP65, H ₂ S (L), 4–20 mA, Charcoal
SPL LH2XAXCXNZZ	Sensepoint XCL Transmitter, Compliance, Safe Area, IP65, H ₂ S (H), 4–20 mA, Charcoal
SPLLG1XAXCXNZZ	Sensepoint XCL Transmitter, Compliance, Safe Area, IP65, H ₂ , 4–20 mA, Charcoal
SPLLN1XAXCXNZZ	Sensepoint XCL Transmitter, Compliance, Safe Area, IP65, NO ₂ , 4–20 mA, Charcoal
SPLLA1XAXCXNZZ	Sensepoint XCL Transmitter, Compliance, Safe Area, IP65, NH ₃ (L), 4–20 mA, Charcoal
SPLLB3XAXCXNZZ	Sensepoint XCL Transmitter, Compliance, Safe Area, IP65, CO ₂ , 4~20 mA, Charcoal, ppm
SPLLB4XAXCXNZZ	Sensepoint XCL Transmitter, Compliance, Safe Area, IP65, CO ₂ , 4~20 mA, Charcoal, vol
SPLLO1XAXWXNZZ	Sensepoint XCL Transmitter, Compliance, Safe Area, IP65, O ₂ , 4–20 mA, White
SPLLF6XAXWXNZZ	Sensepoint XCL Transmitter, Compliance, Safe Area, IP65, CH ₄ (CAT), 4–20 mA, White
SPLLC1XAXWXNZZ	Sensepoint XCL Transmitter, Compliance, Safe Area, IP65, CO (L), 4–20 mA, White
SPLLC2XAXWXNZZ	Sensepoint XCL Transmitter, Compliance, Safe Area, IP65, CO (H), 4–20 mA, White
SPL LH1XAXWXNZZ	Sensepoint XCL Transmitter, Compliance, Safe Area, IP65, H ₂ S (L), 4–20 mA, White
SPL LH2XAXWXNZZ	Sensepoint XCL Transmitter, Compliance, Safe Area, IP65, H ₂ S (H), 4–20 mA, White
SPLLG1XAXWXNZZ	Sensepoint XCL Transmitter, Compliance, Safe Area, IP65, H ₂ , 4–20 mA, White
SPLLN1XAXWXNZZ	Sensepoint XCL Transmitter, Compliance, Safe Area, IP65, NO ₂ , 4–20 mA, White
SPLLA1XAXWXNZZ	Sensepoint XCL Transmitter, Compliance, Safe Area, IP65, NH ₃ (L), 4–20 mA, White
SPLLB3XAXWXNZZ	Sensepoint XCL Transmitter, Compliance, Safe Area, IP65, CO ₂ (ppm), 4~20 mA, White
SPLLB4XAXWXNZZ	Sensepoint XCL Transmitter, Compliance, Safe Area, IP65, CO ₂ (%vol), 4~20 mA, White

Part number	Description
SPLCO1BAXCXNZZ	Sensepoint XCL Transmitter, Safe Area, IP65, O ₂ , 4–20 mA, Charcoal
SPLCO1BARCXNZZ	Sensepoint XCL Transmitter, Safe Area, IP65, O ₂ , 4–20 mA, Relay, Charcoal
SPLCO1BAXWXNZZ	Sensepoint XCL Transmitter, Safe Area, IP65, O ₂ , 4–20 mA, White
SPLCO1BARWXNZZ	Sensepoint XCL Transmitter, Safe Area, IP65, O ₂ , 4–20 mA, Relay, White
SPLCO1BMXCXNZZ	Sensepoint XCL Transmitter, Safe Area, IP65, O ₂ , Modbus, Charcoal
SPLCO1BMRCXNZZ	Sensepoint XCL Transmitter, Safe Area, IP65, O ₂ , Modbus, Relay, Charcoal
SPLCO1BMXWXNZZ	Sensepoint XCL Transmitter, Safe Area, IP65, O ₂ , Modbus, White
SPLCO1BMRWXNZZ	Sensepoint XCL Transmitter, Safe Area, IP65, O ₂ , Modbus, Relay, White
SPLCC1BAXCXNZZ	Sensepoint XCL Transmitter, Safe Area, IP65, CO, 4–20 mA, Charcoal
SPLCC1BARCXNZZ	Sensepoint XCL Transmitter, Safe Area, IP65, CO, 4–20 mA, Relay, Charcoal
SPLCC1BAXWXNZZ	Sensepoint XCL Transmitter, Safe Area, IP65, CO, 4–20 mA, White
SPLCC1BARWXNZZ	Sensepoint XCL Transmitter, Safe Area, IP65, CO, 4–20 mA, Relay, White
SPLCC1BMXCXNZZ	Sensepoint XCL Transmitter, Safe Area, IP65, CO, Modbus, Charcoal
SPLCC1BMRCXNZZ	Sensepoint XCL Transmitter, Safe Area, IP65, CO, Modbus, Relay, Charcoal
SPLCC1BMXWXNZZ	Sensepoint XCL Transmitter, Safe Area, IP65, CO, Modbus, White
SPLCC1BMRWXNZZ	Sensepoint XCL Transmitter, Safe Area, IP65, CO, Modbus, Relay, White
SPLCH1BAXCXNZZ	Sensepoint XCL Transmitter, Safe Area, IP65, H ₂ S (L), 4–20 mA, Charcoal
SPLCH1BARCXNZZ	Sensepoint XCL Transmitter, Safe Area, IP65, H ₂ S (L), 4–20 mA, Relay, Charcoal
SPLCH1BAXWXNZZ	Sensepoint XCL Transmitter, Safe Area, IP65, H ₂ S (L), 4–20 mA, White
SPLCH1BARWXNZZ	Sensepoint XCL Transmitter, Safe Area, IP65, H ₂ S (L), 4–20 mA, Relay, White
SPLCH1BMXCXNZZ	Sensepoint XCL Transmitter, Safe Area, IP65, H ₂ S (L), Modbus, Charcoal
SPLCH1BMRCXNZZ	Sensepoint XCL Transmitter, Safe Area, IP65, H ₂ S (L), Modbus, Relay, Charcoal
SPLCH1BMXWXNZZ	Sensepoint XCL Transmitter, Safe Area, IP65, H ₂ S (L), Modbus, White
SPLCH1BMRWXNZZ	Sensepoint XCL Transmitter, Safe Area, IP65, H ₂ S (L), Modbus, Relay, White
SPLCH2BAXCXNZZ	Sensepoint XCL Transmitter, Safe Area, IP65, H ₂ S (H), 4–20 mA, Charcoal
SPLCH2BARCXNZZ	Sensepoint XCL Transmitter, Safe Area, IP65, H ₂ S (H), 4–20 mA, Relay, Charcoal
SPLCH2BAXWXNZZ	Sensepoint XCL Transmitter, Safe Area, IP65, H ₂ S (H), 4–20 mA, White
SPLCH2BARWXNZZ	Sensepoint XCL Transmitter, Safe Area, IP65, H ₂ S (H), 4–20 mA, Relay, White
SPLCH2BMXCXNZZ	Sensepoint XCL Transmitter, Safe Area, IP65, H ₂ S (H), Modbus, Charcoal
SPLCH2BMRCXNZZ	Sensepoint XCL Transmitter, Safe Area, IP65, H ₂ S (H), Modbus, Relay, Charcoal
SPLCH2BMXWXNZZ	Sensepoint XCL Transmitter, Safe Area, IP65, H ₂ S (H), Modbus, White
SPLCH2BMRWXNZZ	Sensepoint XCL Transmitter, Safe Area, IP65, H ₂ S (H), Modbus, Relay, White
SPLCG1BAXCXNZZ	Sensepoint XCL Transmitter, Safe Area, IP65, H ₂ , 4–20 mA, Charcoal
SPLCG1BARCXNZZ	Sensepoint XCL Transmitter, Safe Area, IP65, H ₂ , 4–20 mA, Relay, Charcoal
SPLCG1BAXWXNZZ	Sensepoint XCL Transmitter, Safe Area, IP65, H ₂ , 4–20 mA, White
SPLCG1BARWXNZZ	Sensepoint XCL Transmitter, Safe Area, IP65, H ₂ , 4–20 mA, Relay, White
SPLCG1BMXCXNZZ	Sensepoint XCL Transmitter, Safe Area, IP65, H ₂ , Modbus, Charcoal
SPLCG1BMRCXNZZ	Sensepoint XCL Transmitter, Safe Area, IP65, H ₂ , Modbus, Relay, Charcoal
SPLCG1BMXWXNZZ	Sensepoint XCL Transmitter, Safe Area, IP65, H ₂ , Modbus, White
SPLCG1BMRWXNZZ	Sensepoint XCL Transmitter, Safe Area, IP65, H ₂ , Modbus, Relay, White

Ordering Information

Part number	Description
SPLCN1BAXCXNZZ	Sensepoint XCL Transmitter, Safe Area, IP65, NO ₂ , 4~20mA, Charcoal
SPLCN1BARCXNZZ	Sensepoint XCL Transmitter, Safe Area, IP65, NO ₂ , 4~20mA, Relay, Charcoal
SPLCN1BAXWXNZZ	Sensepoint XCL Transmitter, Safe Area, IP65, NO ₂ , 4~20mA, White
SPLCN1BARWXNZZ	Sensepoint XCL Transmitter, Safe Area, IP65, NO ₂ , 4~20mA, Relay, White
SPLCN1BMXXCNZZ	Sensepoint XCL Transmitter, Safe Area, IP65, NO ₂ , Modbus, Charcoal
SPLCN1BMRCXNZZ	Sensepoint XCL Transmitter, Safe Area, IP65, NO ₂ , Modbus, Relay, Charcoal
SPLCN1BMXXWNZZ	Sensepoint XCL Transmitter, Safe Area, IP65, NO ₂ , Modbus, White
SPLCN1BMRWXNZZ	Sensepoint XCL Transmitter, Safe Area, IP65, NO ₂ , Modbus, Relay, White
SPLCA1BAXCXNZZ	Sensepoint XCL Transmitter, Safe Area, IP65, NH ₃ (L), 4~20mA, Charcoal
SPLCA1BARCXNZZ	Sensepoint XCL Transmitter, Safe Area, IP65, NH ₃ (L), 4~20mA, Relay, Charcoal
SPLCA1BAXWXNZZ	Sensepoint XCL Transmitter, Safe Area, IP65, NH ₃ (L), 4~20mA, White
SPLCA1BARWXNZZ	Sensepoint XCL Transmitter, Safe Area, IP65, NH ₃ (L), 4~20mA, Relay, White
SPLCA1BMXXCNZZ	Sensepoint XCL Transmitter, Safe Area, IP65, NH ₃ (L), Modbus, Charcoal
SPLCA1BMRCXNZZ	Sensepoint XCL Transmitter, Safe Area, IP65, NH ₃ (L), Modbus, Relay, Charcoal
SPLCA1BMXXWNZZ	Sensepoint XCL Transmitter, Safe Area, IP65, NH ₃ (L), Modbus, White
SPLCA1BMRWXNZZ	Sensepoint XCL Transmitter, Safe Area, IP65, NH ₃ (L), Modbus, Relay, White
SPLCF6BAXCXNZZ	Sensepoint XCL Transmitter, Safe Area, IP65, CH ₄ (CAT), 4~20mA, Charcoal
SPLCF6BARCXNZZ	Sensepoint XCL Transmitter, Safe Area, IP65, CH ₄ (CAT), 4~20mA, Relay, Charcoal
SPLCF6BAXWXNZZ	Sensepoint XCL Transmitter, Safe Area, IP65, CH ₄ (CAT), 4~20mA, White
SPLCF6BARWXNZZ	Sensepoint XCL Transmitter, Safe Area, IP65, CH ₄ (CAT), 4~20mA, Relay, White
SPLCF6BMXXCNZZ	Sensepoint XCL Transmitter, Safe Area, IP65, CH ₄ (CAT), Modbus, Charcoal
SPLCF6BMRCXNZZ	Sensepoint XCL Transmitter, Safe Area, IP65, CH ₄ (CAT), Modbus, Relay, Charcoal
SPLCF6BMXXWNZZ	Sensepoint XCL Transmitter, Safe Area, IP65, CH ₄ (CAT), Modbus, White
SPLCF6BMRWXNZZ	Sensepoint XCL Transmitter, Safe Area, IP65, CH ₄ (CAT), Modbus, Relay, White
SPLCB3BAXCXNZZ	Sensepoint XCL Transmitter, Safe Area, IP65, CO ₂ (ppm), 4~20 mA, Charcoal
SPLCB3BARCXNZZ	Sensepoint XCL Transmitter, Safe Area, IP65, CO ₂ (ppm), 4~20 mA, Relay, Charcoal
SPLCB3BAXWXNZZ	Sensepoint XCL Transmitter, Safe Area, IP65, CO ₂ (ppm), 4~20 mA, White
SPLCB3BARWXNZZ	Sensepoint XCL Transmitter, Safe Area, IP65, CO ₂ (ppm), 4~20 mA, Relay, White
SPLCB3BMXXCNZZ	Sensepoint XCL Transmitter, Safe Area, IP65, CO ₂ (ppm), Modbus, Charcoal
SPLCB3BMRCXNZZ	Sensepoint XCL Transmitter, Safe Area, IP65, CO ₂ (ppm), Modbus, Relay, Charcoal
SPLCB3BMXXWNZZ	Sensepoint XCL Transmitter, Safe Area, IP65, CO ₂ (ppm), Modbus, White
SPLCB3BMRWXNZZ	Sensepoint XCL Transmitter, Safe Area, IP65, CO ₂ (ppm), Modbus, Relay, White
SPLCB4BAXCXNZZ	Sensepoint XCL Transmitter, Safe Area, IP65, CO ₂ (%vol), 4~20 mA, Charcoal
SPLCB4BARCXNZZ	Sensepoint XCL Transmitter, Safe Area, IP65, CO ₂ (%vol), 4~20 mA, Relay, Charcoal
SPLCB4BAXWXNZZ	Sensepoint XCL Transmitter, Safe Area, IP65, CO ₂ (%vol), 4~20 mA, White
SPLCB4BARWXNZZ	Sensepoint XCL Transmitter, Safe Area, IP65, CO ₂ (%vol), 4~20 mA, Relay, White
SPLCB4BMXXCNZZ	Sensepoint XCL Transmitter, Safe Area, IP65, CO ₂ (%vol), Modbus, Charcoal
SPLCB4BMRCXNZZ	Sensepoint XCL Transmitter, Safe Area, IP65, CO ₂ (%vol), Modbus, Relay, Charcoal
SPLCB4BMXXWNZZ	Sensepoint XCL Transmitter, Safe Area, IP65, CO ₂ (%vol), Modbus, White
SPLCB4BMRWXNZZ	Sensepoint XCL Transmitter, Safe Area, IP65, CO ₂ (%vol), Modbus, Relay, White
SPLCC1BAXCXLZZ	Sensepoint XCL Transmitter, Safe Area, IP65, CO, 4~20mA, Charcoal, CoLA
SPLCC1BARCXLZZ	Sensepoint XCL Transmitter, Safe Area, IP65, CO, 4~20mA, Relay, Charcoal, CoLA

C.2 Accessories

Part number	Description
SPXCLCAL	Sensepoint XCL Calibration/Flow Cap
SPXCLDMK	Sensepoint XCL Duct Mount Kit
SPXCLRGP	Sensepoint Fixed Remote Gassing Port
SPXCLGLD	Sensepoint XCL M20 Cable Glands, Black (10 pieces each pack)
SPXCLGLW	Sensepoint XCL M20 Cable Glands, White (10 pieces each pack)

C.3 Consumables

Part number	Description
SPXCLZZ01SS	Sensepoint XCL Replacement Sensor, O ₂
SPXCLZZF6SS	Sensepoint XCL Replacement Sensor, Flam CAT
SPXCLRLC1SS	Sensepoint XCL/XRL Replacement Sensor, CO
SPXCLRLH1SS	Sensepoint XCL/XRL Replacement Sensor, H ₂ S (suitable for both Low and High Range)
SPXCLRLG1SS	Sensepoint XCL/XRL Replacement Sensor, H ₂
SPXCLRLN1SS	Sensepoint XCL/XRL Replacement Sensor, NO ₂
SPXCLRLA1SS	Sensepoint XCL Replacement Sensor, NH ₃
SPXCLRLB3SS	Sensepoint XCL Replacement Sensor - CO ₂ (ppm)
SPXCLRLB4SS	Sensepoint XCL Replacement Sensor - CO ₂ (%vol)
SPXCLFLT	Sensepoint XCL Replacement Sensor Filter (10 pieces each pack)

C.4 Spares

Part number	Description
SPXCLSK1	Sensepoint XCL Service Kit
SPXCLSCC	Sensepoint XCL Sensor Cover, Charcoal
SPXCLSCW	Sensepoint XCL Sensor Cover, White
SPXCLDCC	Sensepoint XCL Decal Cover, Charcoal
SPXCLDCW	Sensepoint XCL Decal Cover, White

Appendix D

Warranty

Honeywell Analytics warrants the Sensepoint XCL gas detector against defective parts and workmanship.

This warranty does not cover consumable, batteries, fuses, normal wear and tear, or damage caused by accident, abuse, improper installation, unauthorized use, modification or repair, ambient environment, poisons, contaminants or abnormal operating conditions.

This warranty does not apply to sensors or components that are covered under separate warranties, or to any 3rd-party cables and components.

In no event shall Honeywell Analytics be liable for any damages or injury of any nature or kind, no matter how caused, that arise from incorrect handling or use of this equipment.

In no event shall Honeywell Analytics be liable for any equipment malfunction or damages whatsoever, including (without limitation) incidental, direct, indirect, special, and consequential damages, damages for loss of business profits, business interruption, loss of business information, or other pecuniary loss, resulting from the incorrect installation or use of this equipment.

Any claim under the Honeywell Analytics Product Warranty must be made within the warranty period and as soon as reasonably practicable after a defect is discovered. Please contact your local Honeywell Analytics Service representative to register your claim.

This is a summary. For full warranty terms please refer to the Honeywell Analytics' *General Statement of Limited Product Warranty*, which is available on request.

Appendix E

Safety Information for Wireless Devices

E.1 FCC Compliance

This device complies with part 15 of the FCC Rules. Operation is subject to the following two conditions: (1) This device may not cause harmful interference, and (2) this device must accept any interference received, including interference that may cause undesired operation.

This transmitter must not be co-located or operated in conjunction with any other antenna or transmitter. This equipment complies with FCC radiation exposure limits set forth for an uncontrolled environment. End users must follow the specific operating instructions for satisfying RF exposure compliance.

NOTE

This equipment has been tested and found to comply with the limits for a Class A digital device, pursuant to part 15 of the FCC Rules. These limits are designed to provide reasonable protection against harmful interference when the equipment is operated in a commercial environment. This equipment generates, uses, and can radiate radio frequency energy and, if not installed and used in accordance with the instruction manual, may cause harmful interference to radio communications. Operation of this equipment in a residential area is likely to cause harmful interference in which case the user will be required to correct the interference at his own expense.

 **CAUTION**

Changes or modifications not expressly approved by the manufacturer responsible for compliance could void the user's authority to operate the equipment.

This device complies with FCC radiation exposure limits set forth for an uncontrolled environment and meets the FCC radio frequency (RF) Exposure Guidelines. This device has very low levels of RF energy that it is deemed to comply without maximum permissive exposure evaluation (MPE). But it is desirable that it should be installed and operated keeping the radiator at least 20 cm or more away from person's body.

E.2 IC Compliance

This device complies with Industry Canada's license-exempt RSSs. Operation is subject to the following two conditions:

- 1) This device may not cause interference.
- 2) This device must accept any interference, including interference that may cause undesired operation of the device

E.3 RED Compliance

Honeywell Analytics Asia Pacific Co., Ltd. hereby declares that this gas detector, Sensepoint XCL, is in compliance with the essential requirements and other relevant provisions of Directive 2014/53/EU.

Appendix F

Certification

Electrical Safety

- UL 61010-1
- CSA C22.2 No. 61010-1
- IEC/EN 61010-1

Electromagnetic Compatibility

- EN 50270:2015

Radio

- RED
- FCC
- BT SIG

Enclosure Protection

- IP65
- Type 4 in accordance with NEMA 250

Gas Performance

- UL 2075 (CH₄ and CO)

Appendix G

Modbus Registers

The Modbus version of Sensepoint XCL allows interaction with the gas detector using Modbus/RTU over an RS-485 physical layer. The Modbus interface provides a means to monitor and interrogate the detector with the addition of being able to reset alarms remotely. The Modbus registers for Sensepoint XCL are given in the following table.

NOTE

Functions associated with the relays (if fitted) is limited to the viewing of their associated parameters. It is not possible to set or control the relays over the Modbus interface.

Modbus Register Address	Information	R/W	Type	Size	Description	Notes
30001	Main SW Version of Instrument	R	u16	1		Upper Byte: Major version Lower Byte: Minor version
30002	EEP Version of Instrument	R	u8	1		
30004 to 3009	Location String	R	string[12]	6		Not used in Sensepoint XCL/XRL
30010	Modbus Slave ID	R	u8	1		
30011	Monitor Status	R	u16	1		1 : Normal 2 : Warm Up after power on 3 : in Inhibit 12 : Calibration
30012	Inhibit Current (mA)	R	u8	1		Not used in Sensepoint XCL/XRL
30013	Reserved	R	u16	1		
30014	Active Alarm	R	u32	2		bit 0 Alarm 1 is active bit 1 Alarm 2 is active bit 1 Alarm 3 is active (not used)
30016 to 30017	Latched Alarm	R	u32	2		bit 0 Alarm 1 is latched bit 1 Alarm 2 is latched bit 2 Alarm 3 is latched (not used)
30018 to 30019	Active Fault	R	u32	2		Upper Two Bytes: fault Lower Two Bytes: warning Bit 0 to Bit 15: warning Bit 16 to Bit 31: fault
30020 to 30021	Latched Fault	R	u32	2		Not used
30022 to 30034	Location Tag	R	string[26]	13		Location tag for BLE scanning
40101	System ID Code	R	u16	1	MSB always 0x26 to facilitate automatic identification. LSB repeat of Modbus address.	Upper Byte: Type Code: 0x26 Lower Byte: My Address
40102	System ID Code	R	u16	1	Identical to 40101	Upper Byte: Type Code: 0x26 Lower Byte: My Address: Dummy Spacer
40103 to 40104	Gas Reading	R	f32	2	The reported gas concentration in current measurement units. For example, methane at 50% LEL would be reported as 50.0 here. This concentration is forced to last reading before switching into inhibit mode during inhibit mode.	
40105	Fault and Warning	R	u16	1	This is the integer representation of the fault status. If any fault exists this will take a value in the range 1200 to 1999. Otherwise, if any warning exists, this will take a value in the range 1 to 999. Normally, this has the value zero.	Fault = 1200 + Number Warning = Number as is

Modbus Register Address	Information	R/W	Type	Size	Description	Notes
40106	Alarm, Fault and Warning State	R	u8	1	This register contains 4 meaningful bits regarding the presence of alarms or faults. The bit assignments are as follows: Bit 0: AL1 active Bit 1: AL2 active Bit 4: Warning active Bit 6: Fault Active All others: For future expansion	bit 0 Alarm 1 is active bit 1 Alarm 2 is active bit 2,3 for future expansion bit 4 Warning is active bit 5 Fault is active bit 6,7 for future expansion Note: Latching relay setting latches Modbus values in register 40006.
40107	Monitor State Monitoring	R	u8	1		1 : Normal 2 : Warm Up after power on 3 : in Inhibit 12 : Calibration
40108	Heart Beat	R	u16	1	This Heartbeat is provided to facilitate detection of communications problems in programming environments where the transport layer communication error information is unavailable. This increments approximately every 5 seconds. It is the responsibility of the system integrator to notify plant personnel if a Modbus master fails to communicate with the Sensepoint XCL/XRL. This register can facilitate this notification	
40109 to 40110	Calibration Due	R	f32	2	This indicates the time remaining before the ECC sensor must be calibrated or replaced. Calibration interval – DaysPassedSinceLastSuccessfulCal	
40111	Measuring Unit	R	u8	1	iMeasurementUnits	0x00 : blank (no measurement unit) 0x01 : 0x02 : mA 0x03 : mg/m ³ 0x04 : g/m ³ 0x05 : 0x06 : ppm 0x07 : kppm 0x08 : LEL·m 0x09 : A 0x0A : dB 0x0B : dBA 0x0C : ppm·m
40112 to 40113	Peak Reading	R	f32	2		Peak Reading
40114	Relay Fitted	R	u16	1		0x00: Relay not fitted, 0x01: Relay fitted
40115	BLE Fitted	R	u16	1		0x00: BLE not fitted, 0x01: BLE fitted

Modbus Register Address	Information	R/W	Type	Size	Description	Notes
40116	Reserved	R	u16	1		
40117	Temperature (Degrees C)	R	s16	1	Transmitter temperature	
40118 to 40122	Reserved					
40123 to 40131	Date and Time	R	string[18]	9	Format is "mm/dd/yy hh:mm:ss"	
40132	Sensor Type	R	u8	1	0x00: ECC 0x01: FL CAT 0x02: IR 0x03: PID 0x04: MOS	
40133 to 40136	Reserved					
40137 to 40138	Microcontroller Operating Voltage	R	f32	2		
40139 to 40140	Microcontroller Reference Voltage	R	f32	2		
40141	BLE Connection Status	R	u8	1		0x00: Not connected, 0x01: Connected
40142 to 40145	Reserved					
40146 to 40152	Gas Name String	R	string[14]	7		
40153	Temperature (Degrees C)	R	s16	1	Transmitter temperature, duplicate	
40154	Temperature (Degrees F)	R	s16	1		
40155	Calibration Due	R	u16	1	Calibration interval - DaysPassedSinceLastSuccessfulCal	
40156	Relay Status	R	u8	1		High nibble : Relay 2 status Low nibble : Relay 1 status 1 : Energized, 0 : De-energized
40157	Supply Voltage	R	f32	2	The voltage supplied to the Sensepoint XCL/XRL at the nominal 24.0 volt input, in millivolts.	
40158	Reserved					
40159	Calibration Interval	R	u16	1		
40160	Alarm Type	R	u8	1		High nibble : Alarm 2 Type Low nibble : Alarm 1 Type 0: Disable, 1: Rising, 2: Falling
40161	Inhibit Timeout	R	u16	1		Not used in Sensepoint XCL/XRL
40162	Relay Configuration	R	u8	1	1011	Bit: 0 to 1: Relay Type 1 (0: Fault, 1: Alarm1, 2: Alarm2) Bit: 2 to 3: Relay Type 2 (0: Fault, 1: Alarm1, 2: Alarm2) Bit: 4 : Initial Relay Status 1 (0: De-energized, 1: Energized) Bit: 5 : Initial Relay Status 2 (0: De-energized, 1: Energized)

Modbus Register Address	Information	R/W	Type	Size	Description	Notes
40163	Relay On Delay Time	R	u16	1		
40164	Relay Off Delay Time	R	u16	1		
40165 to 40166	User configured full scale range	R	f32	2		Display Range (Full Scale)
40167 to 40168	Alarm Threshold 1	R	f32	2		
40169 to 40170	Alarm Threshold 2	R	f32	2		
40171 to 40172	Target Calibration Gas Concentration	R	f32	2		
40173	Gas Type	R	u16	1		0x00: Flammable 0x01: Toxic 0x02: O2 0x03: VOC
40174 to 40175	Voltage Output	R	f32	2		
40176 to 40183	Device Serial Number	R	string[16]	8		
40184 to 40188	BLE FW Version	R	string[10]	5	BLE FW Version	
40189 to 40200	Reserved					
40201	Reset Alarms & Faults	W	u16	1		
40202 to 40207	Reserved					
40208 to 40213	Raw A/D Counts	R	u16[6]	6		

Appendix H

Contact Information

For more contact information, visit www.sps.honeywell.com.

Americas

Honeywell Analytics Inc.
405 Barclay Blvd. Lincolnshire, IL 60069, USA
Tel: +1 847 955 8200
Toll-free: +1 800 538 0363
Fax: +1 847 955 8210
detectgas@honeywell.com

Europe, Middle East, Africa

Life Safety Distribution GmbH
Javastrasse 2, 8604 Hegnau, Switzerland
Tel: +41 (0)44 943 4300
Fax: +41 (0)44 943 4398
gasdetection@honeywell.com

Asia Pacific, India

Honeywell Co., Ltd.
5F Sangam IT Tower, 434 World Cup Buk-ro, Mapo-gu, Seoul 03922,
Republic of Korea
Tel: +82 (0)2 6909 0300
India Tel: +91 124 4752700
analytics.ap@honeywell.com

Honeywell

Keep this manual for later use.

3017M5002_6 ECN-00230030
© 2023 Honeywell Co., Ltd.