

# GM16 GM64 GM128

## Addressable Controller Range

Multiple channel capacity  
options (16 / 64 / 128)

Customisable controller  
configuration

Addressable capability

Full functionality and  
remote visibility of controller  
via internet browser



# Addressable Controllers

## 3 Addressable Digital and 4-20ma Analog Controller Introductions

- GM16 – 16 channel addressable controller
- GM64 – 64 channel addressable controller
- GM128 – 128 channel (2 x GM64 addressable controllers paired together)



Crowcon's new range of addressable digital and 4-20ma analog controllers are modular, flexible, easy to configure and user friendly.

Simultaneous channel and alarm display via colour LCD screen for complete visibility and control over all live channels in system setup directly from non-intrusive controller display panel or remotely with direct to webpage live feed communication functionality on any device with internet access.



### Features

#### Modular design build

Select how controller is configured  
Choose the configuration for your application:  
Select how many channel inputs are required  
Channel input communication type (MA, MV or Addressable):  
Select how many relay outputs are required  
Reduce complexity and cost by only including what is required for your application

#### Multiple display options

Display all active channels on the same screen  
Ability to combine channels into zones and view up to 8 zones simultaneously on one screen  
Trends screens allows view of last 24 hours or last 30-minute gas readings (current, max, min and average)

#### Multiple communications

4-20mA analog, RS-485 MODBUS and HART enabled communications as standard

## Small enclosure

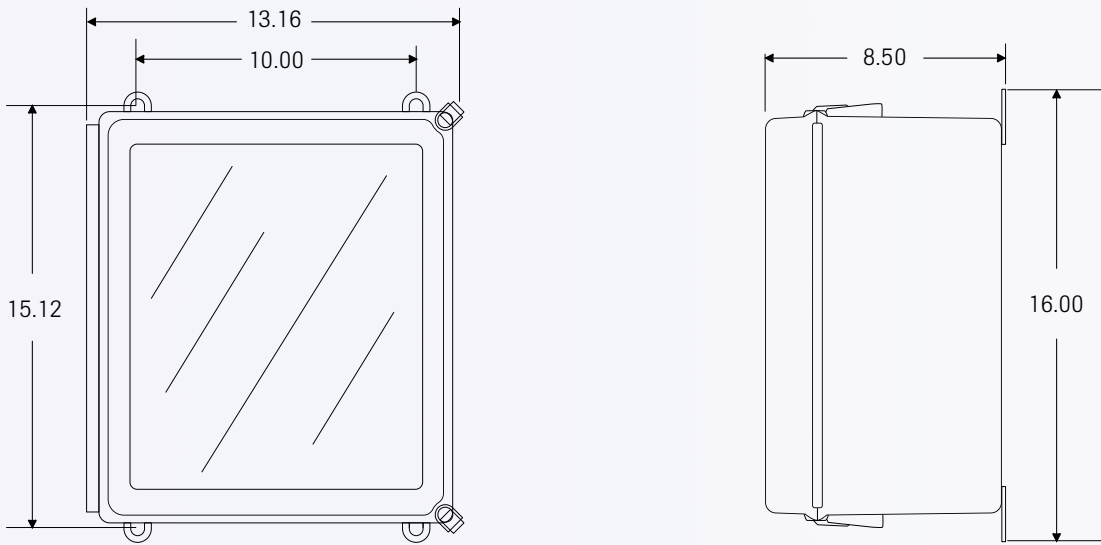

## Large enclosure

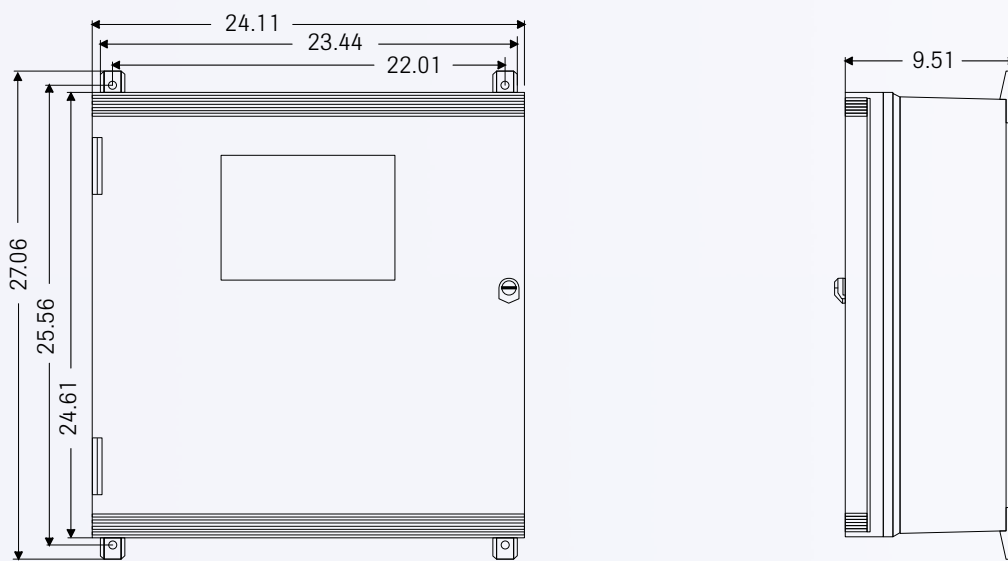

## Rack mounting

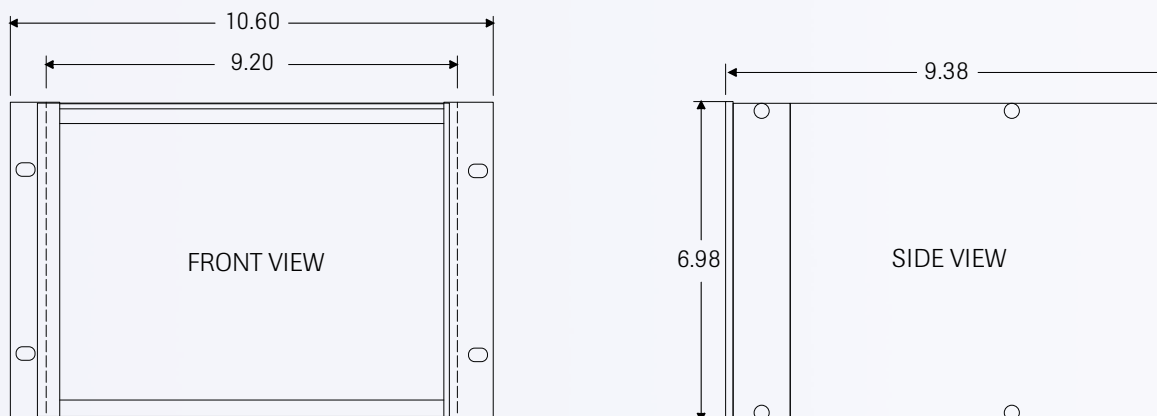

\*All dimensions are in inches

## Be in control of your controller

System configuration	Ability to name the controller Create up to eight zones which can be named Choose how many channels are displayed simultaneously
Channel configurations	Choose alarm setpoints Select data each channel displays
Relay configurations	Set value for high and lows trips for each relay Choose colour for set trip value Set delays to each relay option
Copy channel	Copy and Paste an already configured channel to a new channel to save time for multiple identical channel configurations
Configuration upload / download	Set up configuration remotely via device and download onto SD card Inserting SD card into controller will automatically upload saved configuration

## Specification

Small enclosure	Enclosure material	Fibreglass
	Dimensions	406.4 x 334.3 x 215.9mm (16.00 x 13.16 x 8.50 ins)
	Weight	7.7 Kg (17 lbs)
	Ingress Protection	NEMA 4X
Large enclosure	Enclosure material	Fibreglass
	Dimensions	612.4 x 687.3 x 241.6mm (24.11 x 27.06 x 9.51 ins)
	Weight	25 Kg (55lbs)
	Ingress Protection	NEMA 4X
Rack	19 inch rack mount option also available	
Power	Typical power use without detector heads is 20 to 50 Watts	
Electrical output	4-20mA 2 wire current sink 4-20mA 3 wire current source RS-485 Modbus RTU Relays 5 Amp 30 Volt RJ45 network connection	
Operating temperature	-20°C to + 50°C	
Humidity	0 to 90% non-condensing	
Repeatability and drift	Digital channels – no controller variability Analog channels – <1% FSD change over a 1 year period	
Approvals	May be used in a non-hazardous area as part of an intrinsically safe system	
EMC compliance	CE marked	

### Disclaimer

Every effort has been made to ensure the accuracy of this document at the time of printing. In accordance with the company's policy of continued product improvement Crowcon Detection Instruments Limited reserves the right to make product changes without notice. The products are routinely subject to a programme of testing which may result in some changes in the characteristics quoted. Technical information contained in this document or otherwise provided by Crowcon are based upon records, tests, or experience that the company believes to be reliable, but the accuracy, completeness, and representative nature of such information is not guaranteed.

Many factors beyond Crowcon Detection Instruments' control and uniquely within user's knowledge and control can affect the use and performance of a Crowcon product in a particular application.

As the products may be used by the client in circumstances beyond the knowledge and control of Crowcon Detection Instruments Limited, we cannot determine the relevance of these to an individual customer's application. It is the clients' sole responsibility to carry out the necessary tests to evaluate the usefulness of the products and review all applicable regulations and standards to ensure their safety of operation in a particular application.