

SPECIFICATION

- Gases Detected**  
Combustible gases in the LEL range with the sensitivity dependent on gas type.
- Range**  
0 - 100% LEL Methane. Other gas ranges may vary.
- Operating Temperature Range**  
-40°C to +80°C (See Certification)
- Operating Humidity Range**  
20% to 90% RH continuous.  
10% to 99% intermittent - non condensing.
- Operating Pressure Range**  
90 to 110kPa.
- Warm-up Time**  
10 minutes
- Voltage Range**  
2.9V to 3.5V bridge (at 200mA drive current).
- Power Consumption**  
700mW.
- Signal Output**  
mV bridge.
- Sample Flow Rate**  
Recommended 1 to 1.5 litres/minute.
- Poisoning**  
The sensing elements may become inactive after extensive exposure to silicones, halogenated hydrocarbons, heavy metals or sulphur compounds.
- Expected Operating Life**  
5 years.
- IP Rating**  
IP65 standard; IP67 with Weather Protection.
- Dimensions**  
56mm diameter x 74mm long (maximum)
- Weight**  
190g.

Operating Instructions



Sensepoint LEL Combustible Sensor

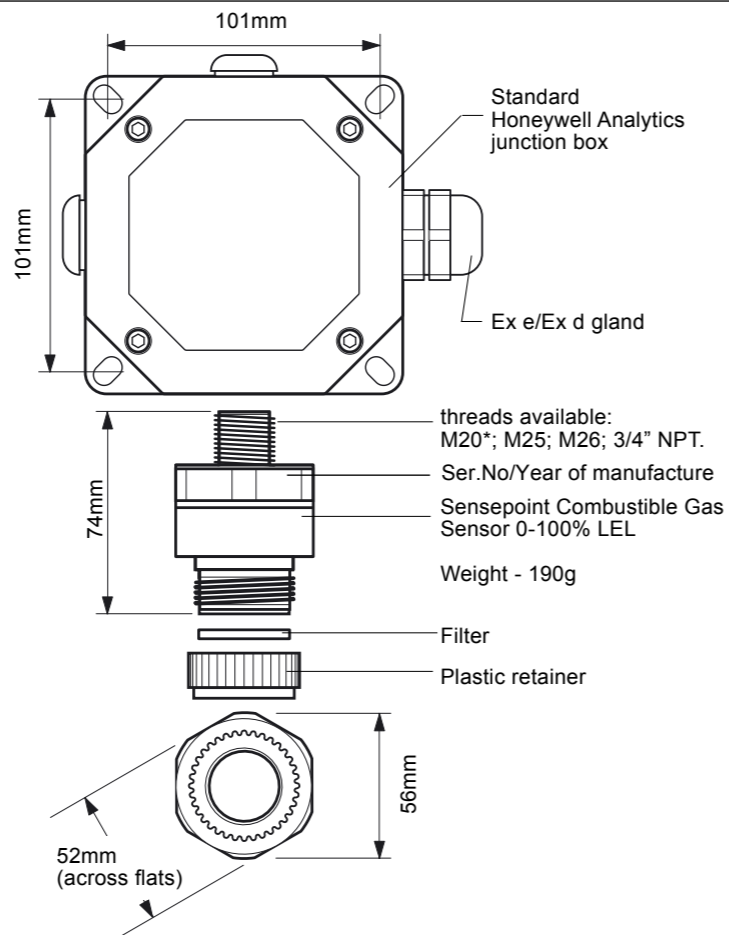

SAFETY



WARNINGS

- This apparatus is not suitable for use in oxygen enriched atmospheres (>21%v/v). Oxygen deficient atmospheres (<10%v/v) may suppress sensor output.
- Refer to local or national regulations relative to installation at the site.
- Operators should be fully aware of the action to be taken if the gas concentration exceeds an alarm level.
- Installation should consider not only the best placing for gas leakage related to potential leak points, gas characteristics and ventilation, but also where the potential of mechanical damage is minimized or avoided.
- Electrostatic risk - Do not rub or clean with solvents. Clean with a damp cloth. High velocity airflows and dusty environments can cause hazardous electrostatic charges

CAUTIONS

- Atmospheres above 100% LEL may suppress the sensor reading.
- Do not modify or alter the sensor construction as essential safety requirements may be invalidated.
- Install using certified Ex e or Ex d junction box, connectors and glanding.
- Dispose of in accordance with local disposal regulations. Materials used -Fortron® (PPS-Polyphenylene Sulphide)
- This equipment is designed and constructed as to prevent ignition sources arising, even in the event of frequent disturbances or equipment operating faults.
- The purchaser should make the manufacturer aware of any External effects or Aggressive substances that the equipment may be exposed to.

NOTE: The control card must have a suitably rated fuse.

SPARE PARTS

- Sensor.....2106B1200 (M20)
- Sensor.....2106B1201 (M25)
- Sensor.....2106B1202 (M26)
- Sensor.....2106B1204 (3/4NPT)
- Weather protection.....02000-A-1640
- Sensor filter.....00780-F-0018
- Flow housing.....02000-A-1645
- Collecting cone.....02000-A-1642
- Junction box (std).....00780-A-0100
- High temperature junction box.....2052D0001
- High temperature weather protection.....00780-A-0076

To reorder a complete new sensor, see the label on the product leads, or contact Honeywell Analytics.

CERTIFICATION LABEL

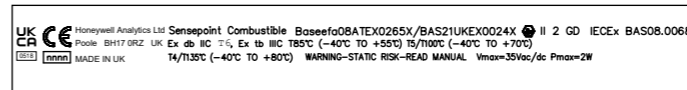

CHINA ROHS

部件名称	有害物质					
	铅 (Pb)	汞 (Hg)	镉 (Cd)	六价铬 (Cr(VI))	多溴联苯 (PBB)	多溴二苯醚 (PBDE)
PCB板	X	0	0	0	0	0
气体传感器	X	0	0	0	0	0

本表格中未列出的所有部件和配件包含的有害物质都没有超过 GB/T 26572 所要求的限制。  
本表格依据 SJ/T 11364 的规定编制  
0 : 表示该有害物质在该部件所有均质材料中的含量均在 GB/T 26572 规定的限量要求以下。  
X : 表示该有害物质至少在该部件的某一均质材料中的含量超出 GB/T 26572 规定的限量要求。

2004Y2003C\_1\_A04826 China RoHS Declaration 03 (Pb,PCB,Pb Sensor) 16 May 2016

1. INTRODUCTION & 2. ASSOCIATED DOCUMENTATION

ATEX SPECIAL CONDITIONS FOR SAFE USE

The detector must be protected from impact. The integral supply cables must be protected from impact and terminated in a suitable terminal facility. The detector is considered to present a potential electrostatic risk and must not be located in high air flows or rubbed.

1. INTRODUCTION

Sensepoint is a sealed disposable sensor for the detection of flammable gases and is designed for use with an approved junction box.

It employs a catalytic pellistor sensor device which is used as part of a bridge measuring circuit.

Sensepoint is certified for hazardous areas to EN60079 and is protected against water and dust ingress to IP67. The installation must be consistent with the certification approval.

The sensor is available in M20, M25, M26 or 3/4 NPT thread versions. The sensors can be fitted with accessories such as Weather Protection, Flow Housings (for use when calibrating the sensor and in sampling systems), and a Collecting Cone for the detection of gases which are lighter than air

2. ASSOCIATED DOCUMENTATION

2106M0502 Sensepoint Technical Handbook.

Refer to the relevant control system manual for connection information.



Find out more  
[www.sps.honeywell.com](http://www.sps.honeywell.com)

Contact Honeywell Analytics:

**Europe, Middle East, Africa**  
Life Safety Distribution GmbH  
Tel: 00800 333 222 44 (Freephone no.)  
Tel: +41 (0)44 943 4380 (Alternative no.)  
Middle East Tel: +971 4 450 5800 (Fixed Gas Detection)  
Middle East Tel: +971 4 450 5852 (Portable Gas Detection)  
[gasdetection@honeywell.com](mailto:gasdetection@honeywell.com)

**Americas**  
Honeywell Analytics Inc.  
Tel: +1 847 955 8200  
Toll free: +1 800 538 0363  
[detectgas@honeywell.com](mailto:detectgas@honeywell.com)

**Asia Pacific**  
Honeywell Co., Ltd.  
Tel: +82 (0) 2 6909 0300  
India Tel: +91 124 4752700  
China Tel: +86 10 5885 8788-3000  
[analytics.ap@honeywell.com](mailto:analytics.ap@honeywell.com)

**Technical Services**  
EMEA: [HAexpert@honeywell.com](mailto:HAexpert@honeywell.com)  
US: [ha.us.service@honeywell.com](mailto:ha.us.service@honeywell.com)  
AP: [ha.ap.service@honeywell.com](mailto:ha.ap.service@honeywell.com)  
[www.sps.honeywell.com](http://www.sps.honeywell.com)

**Please Note:**  
While every effort has been made to ensure accuracy in this publication, no responsibility can be accepted for errors or omissions. Data may change, as well as legislation, and you are strongly advised to obtain copies of the most recently issued regulations, standards, and guidelines. This publication is not intended to form the basis of a contract.

3. INSTALLATION

Installation and service must be performed by a qualified installation engineer with the power to the sensor disconnected.

The Sensepoint must be fitted into a suitably approved Ex e or Ex d junction box fitted with a suitably approved cable gland. This should be correctly installed before use.

The sensor should be installed in a location free from direct heat sources. For optimum protection against water ingress ensure that the sensor is installed facing downwards.

See the Sensepoint Gas Sensors Technical Handbook for installation in a duct or in forced air conditions.

Remove the sensor's protective disc before use by unscrewing the filter housing, removing the filter and then the disc. Discard the protective disc. Refit the filter into the filter housing and replace the filter housing on the sensor.

The field connections should be three-core multi-strand cable with a maximum conductor size of 2.5mm<sup>2</sup> (14AWG). A screened cable is recommended for optimum performance.

The sensor should be fitted into a threaded hole within the junction box and locked in place with a lock nut. Ensure that junction box thread is compatible with sensor thread.

Connect the field and Sensepoint wiring to the junction box connector block as shown in the following diagram. The unit requires 200mA current with a nominal 3V supply.

4. CALIBRATION

4.2 CROSS CALIBRATION

**Caution:** Where the user calibrates any sensor using a different gas, responsibility for identifying and recording calibration rests with the user. Refer to the local regulations where appropriate.

When the Sensepoint Combustible LEL sensor is to be calibrated with a gas which is different to the gas or vapour to be detected, it is necessary to calculate the effective concentration of the calibration gas as follows:

**Note:** Table 1 lists the gases according to the reaction they produce at a given detector. An eight star (8\*) gas produces the highest output, while a one star (1\*) gas produces the lowest output.

- Obtain the star rating for the calibration gas and the gas to be detected from table 1.
- Using table 2, look up the correction factor.
- Multiply the Calibration Gas concentration (in %LEL) by the correction factor to get the effective concentration.
- Use the effective concentration when setting up the control card during the calibration procedure.

Table 1 – Star Rating of gases

Gas	CAS Number	LEL (%v/v)	Star Rating
Acetone	67-64-1	2.5	5
Ammonia	7664-41-7	15.0	7
Benzene	71-43-2	1.2	3

Wiring connections are:-

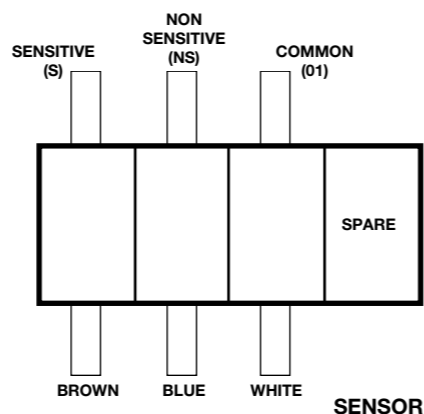

Following installation the sensor must be calibrated.

4. SENSOR CALIBRATION

**Caution:** Calibration procedures should only be carried out by qualified personnel.

**Note:** Sensors should be calibrated at concentrations representative of those to be measured. It is always recommended that the Sensepoint sensor is calibrated with the target gas it is to detect. If this is not possible, cross calibration should be performed.

Since combustible sensors require oxygen for correct operation, a mixture of gas in air should be used for calibration purposes.

4. CALIBRATION

Butane	106-97-8	1.4	4
Butanone	78-93-3	1.8	4
Butyl Acetate	123-86-4	1.3	2
Butyl Acrylate	141-32-2	1.2	2
Cyclohexane	110-82-7	1.2	4
DiEthyl Ether	60-29-7	1.7	4
Ethane	74-84-0	2.5	5
Ethanol	64-17-5	3.1	5
Ethyl Acetate	141-78-6	2.2	4
Ethylene	74-85-1	2.3	5
Heptane	142-82-5	1.1	3
Hexane	110-54-3	1.0	3
Hydrogen	1333-74-0	4.0	6
Methane	74-82-8	4.4	6
Methanol	67-56-1	5.5	5
MIBK	108-10-1	1.2	3
Octane	111-65-9	0.8	2
Pentane	109-66-0	1.4	3
Propan-2-ol	67-63-0	2.0	3
Propane	74-98-6	1.7	4
Propylene	115-07-1	2.0	5
Styrene	100-42-5	1.1	2
TetraHydroFuran	109-99-9	1.5	3
Toluene	108-88-3	1.1	3
TriEthylAmine	121-44-8	1.2	4
Xylene	1330-20-7	1.0	2

4.1 CALIBRATION PROCEDURE

The calibration adjustments are carried out at the control card and gassing is performed at the sensor.

- Apply power and allow the sensor to warm up for 10 minutes.
- First ensure there is no gas present on the sensor. If combustible gas is suspected to be in the vicinity of the Sensepoint sensor, fit a Flow Housing accessory and flow clean air over the sensor.
- Set the zero reading on the control system.
- Remove the filter housing or accessory and replace it with a Flow Housing accessory, if not already fitted.
- Connect the Flow Housing input to a regulated cylinder, containing a known concentration of target gas at approximately the sensor alarm point (e.g. 50% LEL Methane in air), using nylon or PTFE tubing.

**Caution:** As some test gases may be hazardous, the Flow Housing outlet should exhaust to a safe area.

- Pass the gas through the Flow Housing at a flow rate of approximately 1 to 1.5 litres per minute. Allow the sensor two to three minutes to stabilise.
- Adjust the control card to indicate the concentration of the target gas being applied

**Note:** It is useful to record the mV output of the sensor, via the control card, throughout the life of the sensor to ensure that there are no poisoning effects that will reduce the sensor performance. This would be indicated by a reduction in the mV output for the same gas concentration. It is recommended that the sensor is replaced when 60% loss has occurred.

For calibration using the Weather Protection in high flow applications refer to the technical handbook.

4. CALIBRATION

Table 2 – Correction Factor

Star Rating of Calibration Gas	Star Rating of Gas to be Detected							
	8*	7*	6*	5*	4*	3*	2*	1*
8*	1.00	1.24	1.52	1.89	2.37	2.98	3.78	4.83
7*	0.81	1.00	1.23	1.53	1.92	2.40	3.05	3.90
6*	0.66	0.81	1.00	1.24	1.56	1.96	2.49	3.17
5*	0.53	0.66	0.80	1.00	1.25	1.58	2.00	2.55
4*	0.42	0.52	0.64	0.80	1.00	1.26	1.60	2.03
3*	0.34	0.42	0.51	0.64	0.80	1.00	1.27	1.62
2*	0.26	0.33	0.40	0.50	0.63	0.79	1.00	1.28
1*	0.21	0.26	0.32	0.39	0.49	0.62	0.78	1.00

IMPORTANT

Assuming an average sensor performance, the sensitivity information in tables 1 and 2 is normally accurate to ± 20%.

Example

- Target gas to be detected is Butane. The calibration gas available is 46%LEL Methane.
- The star rating of Methane is 6 and Butane is 4.
- From Table 2, the correction factor is 1.56.
- The control card should therefore be told the concentration is (46.0 x 1.56) = 72%LEL in order to give an accurate reading for Butane using Methane as a calibration gas.

Routine Maintenance Schedule

Frequency	Maintenance Action	Equipment Required
6 monthly	Check the zero and span	Test Gas, Regulator, Flow Housing
On gas alarm	Check the zero and span Replace the sensor if necessary	Test Gas, Regulator, Flow Housing
3 monthly	Check the filters for cleanliness	
5 yearly	Replace the sensor if required	

Changing the Filter

- Unscrew and remove the filter housing/retainer or accessory from the sensor body.
- Remove the old filter and replace with a fresh filter.
- Replace the filter housing/retainer or accessory.

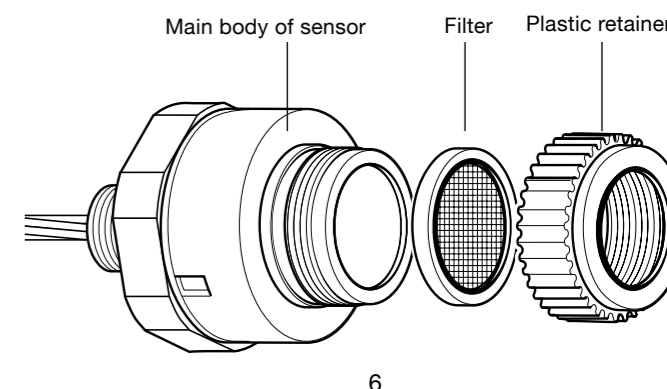

6. FAULT FINDING

6. FAULT FINDING

**Caution:** There are no user serviceable parts within the Sensepoint and attempted changes may invalidate the certification requirements.

Sensor reads non zero all the time:

- Gas could be present, ensure there is no target gas in the atmosphere.

Sensor reads non zero when no gas is present:

- Adjust the control system zero.

Sensor reads low when gas is applied:

- Adjust the control system span.

Sensor reads high when gas is applied:

- Adjust the control system span.

Sensor reads zero when gas is applied:

- Check the wiring.
- Check the dust protection disc is removed from the filter housing.
- Check the sensor is not obstructed.
- Check the sinter and filters are not obstructed.
- Replace the sensor if failure is suspected.