

**Sensepoint XCD RFD
(Remote Flammable Detector)**

1 Safety

Ensure that this Operating Manual is read and understood BEFORE installing / operating / maintaining the equipment. Pay particular attention to Warnings and Cautions. All document Warnings are listed here and repeated where appropriate at the start of the relevant chapter(s) of this Operating Manual. Cautions appear in the sections/sub-sections of the document where they apply

WARNINGS

Sensepoint XCD RFD is designed for installation and use in Zone 1 or 2 hazardous areas in many countries including Europe, and for Class I, Division 1, Groups B, C & D Hazardous Areas in the Americas.

Installation must be in accordance with the recognized standards of the appropriate authority in the country concerned.

Access to the interior of the detector, when carrying out any work, must only be conducted by trained personnel.

Before carrying out any work ensure local regulations and site procedures are followed. Appropriate standards must be followed to maintain the overall certification of the detector.

If using an anti-seize compound, the threads should be thinly coated with an approved silicone free compound e.g. petroleum jelly

To reduce the risk of ignition of hazardous atmosphere, de-classify the area or disconnect the equipment from the supply circuit before opening the detector enclosure. Keep assembly tightly closed during operation.

Never attempt to open a junction box/enclosure or replace/reit the sensor in potentially hazardous atmospheres while power is still applied to the transmitter.

The detector must be earthed/grounded for electrical safety and to limit the effects of radio frequency interference. Earth/ground points are provided inside and outside the unit. The internal grounding shall be used as the primary equipment ground. The external terminal is only a supplemental bonding connection where local authorities permit or require such a connection.

Ensure that all screens/instrument earth/clean earth wiring is earthed/grounded at a single point (either at the controller or detector - BUT NOT BOTH) to prevent false readings or alarms that may occur due to potential earth/ground loops.

Take care when handling sensors as they may contain corrosive solutions.

Do not tamper with or in any way disassemble the sensor.

Do not expose to temperatures outside the recommended ranges.

Do not expose sensors under storage conditions to organic solvents or lammable liquids.

Refer to the local or national regulations relative to the installation at the site. For Europe see EN60079-29-2, EN60079-14 and EN61241-14.

Only assessed for ATEX for ignition hazards.

This equipment is designed and constructed as to prevent ignition sources arising, even in the event of frequent disturbances or equipment operating faults. Note: The control card must have a suitably rated fuse.

The sensor head must be fitted with the supplied weather protection, and mounted so that the sinter is pointing downward to provide ingress protection IPX6.

The weather protection is a potential electrostatic charging hazard. The manufacturer's instructions should be observed.

For Safety reasons, this equipment must be operated and serviced by qualified personnel only

(Pour des raisons de securite, Cet equipment doit etre utilise, Entretenu et repare uniquement par un personnel qualifie)

EMI signal may cause incorrect operations.

Any rapid upscale reading followed by a declining or erratic reading may indicate a gas concentration beyond the upper scale limit which may be hazardous.

2 Information

This manual is for use with the Sensepoint XCD RFD range transmitters only.

The Start-up/Surge/In rush current is dependant on the type of power supply used. The typical start-up current for Sensepoint XCD RFD is less than 800mA. Measure the start-up current using the specific power supply before installation to ensure suitability for your application.

Honeywell Analytics can take no responsibility for installation and/or use of its equipment if not done so in accordance with the appropriate issue and/or amendment of the Technical Manual.

The reader of this Operating Manual should ensure that it is appropriate in all details for the exact equipment to be installed and/or operated. If in doubt, contact Honeywell Analytics for advice.

The following types of notices are used throughout this Operating Manual:

WARNING

Identifies a hazardous or unsafe practice which could result in severe injury or death to personnel.

Caution: Identifies a hazardous or unsafe practice which could result in minor injury to personnel, or product or property damage.

Note: Identifies useful/additional information.

Every effort has been made to ensure the accuracy of this document; however, Honeywell Analytics can assume no responsibility for any errors or omissions in this document or their consequences.

Honeywell Analytics would greatly appreciate being informed of any errors or omissions that may be found in the content of this document.

For information not covered in this document, or if there is a requirement to send comments/corrections about this document, please contact Honeywell Analytics using the contact details given on the back page.

Honeywell Analytics reserve the right to change or revise the information supplied in this document without notice and without obligation to notify any person or organization of such revision or change. If information is required that does not appear in this document, contact the local distributor/agent or Honeywell Analytics.

3 Table of contents

1 Safety	2
2 Information	3
4 Introduction	6
4.1 Transmitter.....	7
4.2 Flammable Gas sensors.....	7
4.2.1 Sensepoint XCD flammable gas sensors.....	8
4.2.2 Sensepoint LEL Flammable gas sensors.....	8
4.2.3 705 LEL flammable gas sensors (UL approved).....	9
4.3 Accessories.....	9
4.4 Options.....	11
4.4.1 Modbus®.....	11
5 Installation	13
5.1 Mounting and location.....	14
5.2 Mounting the transmitter.....	14
5.3 Installing the sensor.....	15
6 Electrical connections	17
6.1 Transmitter Wiring.....	18
6.2 Terminal connections.....	19
6.3 Power.....	20
6.4 Cabling.....	21
6.5 Cable and Earth/Ground regimes.....	21
6.6 Ground Terminal Wiring.....	22
7 Default configuration	23
8 Normal Operation	24
8.1 Display Screen.....	24
8.2 System Status.....	25
8.3 Magnetic Wand Activation.....	26
8.4 Operation Mode Structure.....	26
9 First time switch on (Commissioning)	27
10 Response Check and Calibration	29
10.1 Zeroing and span calibration.....	29
11 General Maintenance	33
11.1 Operational Life.....	33
12 Servicing	34
12.1 Sensor replacement.....	34
12.2 Replacing Modules within the Transmitter.....	36
12.3 Faults and Warnings.....	37
13 Menu's and Advanced Configuration	38
13.1 Abort Function.....	38
13.2 Configuration Mode.....	38
13.3 Sensor / Gas Selection.....	44
13.4 Review Mode.....	46
14 General specification	49

15 Ordering information	50
16 Warranty statement	52
17 Installation Drawing	53
17.1 Mechanical Installation Drawing	53
17.2 Electronic Connection Drawing.....	54
17.3 Duct Mounting Drawing	56
17.4 Collecting Cone Drawing	57
17.5 Mounting Bolt Assy Drawing	58
17.6 Mounting Bracket Drawing.....	55
17.7 Sensepoint XCD RFD Sensor	59
17.8 Control Drawing	61
18 Certification	63
18.1 China GB Ex and PA.....	63
18.2 Korea KTL.....	66
18.3 European ATEX	67
18.4 International IEC	69
18.5 Sensepoint XCD ATEX Name Plate	71
18.6 Sensor Cartridges Label	72
19 Cross Interference and Cross Calibration	73
19.1 Cross Calibration Flammable Gas Detector	73
19.2 Meter Multiplication Factors for Sensepoint XCD-IR Propane.....	76
19.2 Meter Multiplication Factors for Sensepoint XCD-IR Propane.....	76
A.1 Modbus® and the XCD	77
A.2 Modbus® Registers	78

4 Introduction

The Sensepoint XCD RFD (“Exceed RFD”) transmitter allows the user to either directly or remotely mount a flammable gas sensor from the Sensepoint XCD , Sensepoint and 705 sensor ranges. The remote sensor can be located up to 30 meters (100 feet) from the transmitter. The transmitter features a display and three programmable relays for controlling external equipment e.g. alarms, sirens, valves or switches. The transmitter provides an industry standard 3-wire, 4-20mA source or sink output for connection to a dedicated gas detection control system or PLC.

The construction of Sensepoint XCD RFD allows it to be used in hazardous area locations; it may also be used in other areas not classified as hazardous. Sensepoint XCD RFD is suitable for use in Zone 1 or 2 hazardous areas (International).

Calibration and maintenance is carried out using a Magnetic Wand, this allows a single user to undertake routine maintenance without needing to access internal components.

Sensepoint XCD RFD comprises of the main parts as shown below.

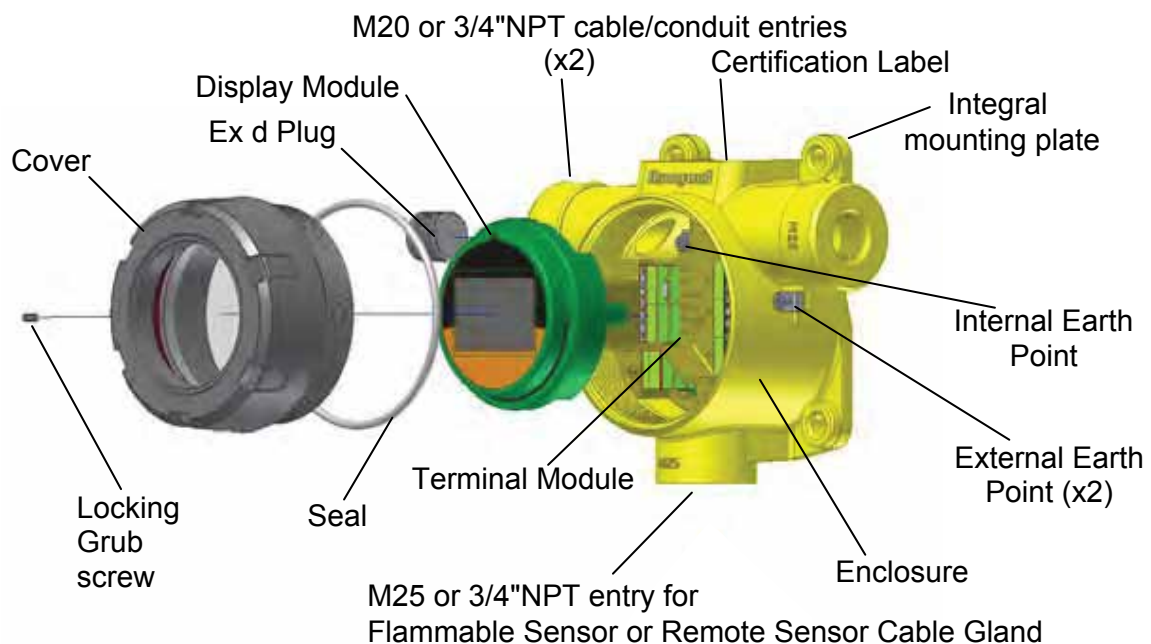


Diagram 1. – Exploded View

4.1 Transmitter

The transmitter enclosure has three threaded entries. The two cable entries either side of the upper part of the transmitter housing are for connecting the power source, signal output and relay contacts to associated signalling equipment. The bottom entry allows local (direct) mounting of the appropriate sensor, or cable entry when using a remotely mounted sensor. These three entries are 3/4" NPT for the Americas. For Europe and most other regions of the world, the two cable entries are provided with an M20 thread and the bottom entry is M25 for the sensor.

A local LCD provides gas type, concentration, alarm and operating status. The display provides numerical, bar graph and icon information.

Diagnostic information may also be displayed when the transmitter is interrogated using a magnet. The transmitter cover has a glass window which allows use of the Magnetic Wand to activate the three user interface magnetic switches that are located on the front of the display module. The magnet also enables a non intrusive, one-man calibration and configuration facility for the Sensepoint XCD RFD.

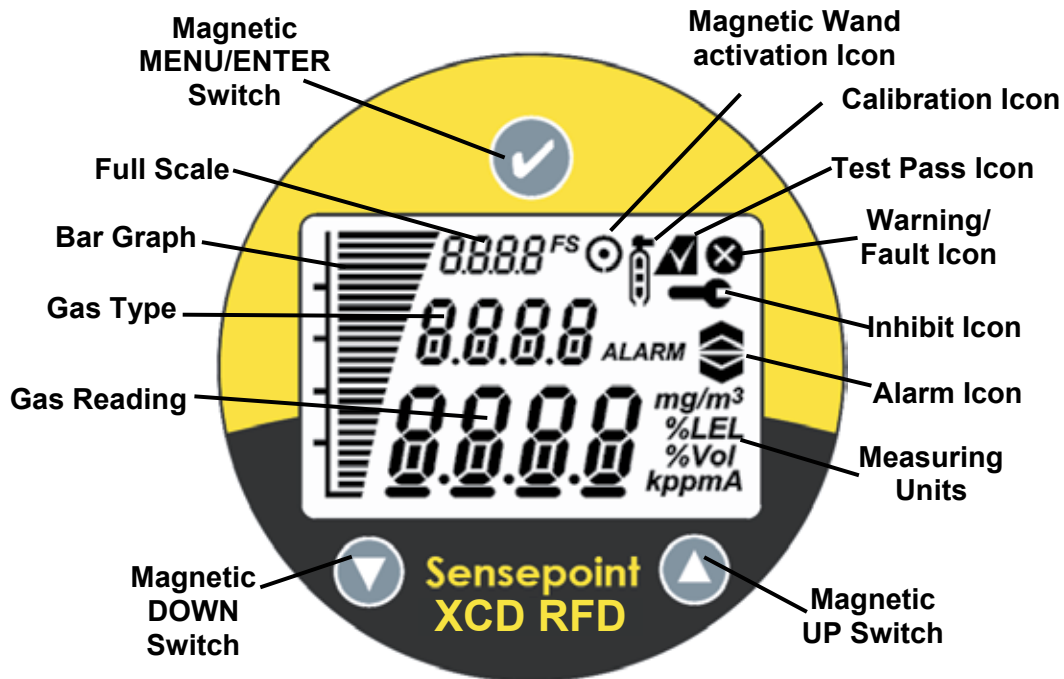


Diagram 2: Sensepoint XCD RFD Display and Magnetic Switches

4.2 Flammable Gas sensors

Sensepoint XCD RFD is designed to work with the flammable sensors from the Sensepoint XCD, 705 and Sensepoint sensor ranges. Sensepoint XCD sensors use NDIR infrared and electro-catalytic technologies. The Sensepoint XCD range is ATEX approved for use throughout Europe and many parts of the world.

Please refer to chapter 15 'Ordering information' for more detail information.

4.2.1 Sensepoint XCD flammable gas sensors

Sensepoint XCD flammable gas sensors are ATEX approved for use in Zone 1 or 2 hazardous areas. Two versions are available: IR and CAT versions. For more sensor specific details, refer to the Quick Start Guide of Sensepoint XCD Remote Flammable Sensor (PN: 3001M5022_1). These sensors are not approved for use in the Americas or Canada.

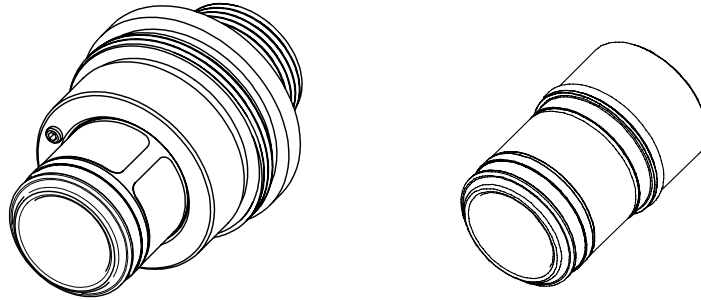


Diagram 3: Sensepoint XCD Flammable Sensor and Plug-in Cartridge

4.2.2 Sensepoint LEL Flammable gas sensors

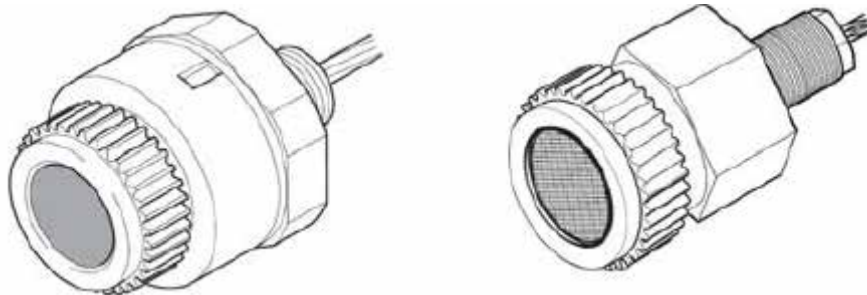
Standard LEL Version

The standard LEL sensor is available for use in temperatures up to 80°C (remote mounting only) and detects gas concentrations up to 100% LEL of a target gas with a resolution in the region of 1% LEL, depending on the gas being detected. The sensor is available with M25 thread. M20 or 3/4" NPT threads are options.

High temperature LEL Version

The high temperature version is available for use in temperatures up to 150°C (remote mounting only) and ranges of 0-20%LEL or 0-100%LEL depending on transmitter or controller. The sensor is available with M25 thread. M20 or 3/4" NPT threads are options.

Details of connecting these sensors with the Sensepoint XCD RFD transmitter are given in sections 5 and 6. For more sensor specific details, refer to the Technical Handbook Part No. 2106M0502 or their individual manuals (Sensepoint HT Sensor Quick Start Guide Part No: 2106M0523, Sensepoint LEL Operating Instructions Part No: 2106M0501). These sensor are not approved for use in the Americas or Canada.



Standard LEL version

High Temperature LEL version

Diagram 4: Sensepoint LEL flammable sensors

4.2.3. 705 LEL Flammable gas sensors (UL Approved)

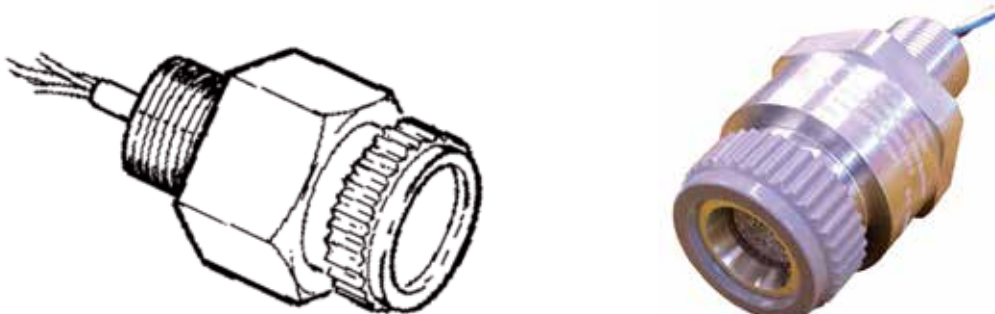
Standard LEL version

The standard LEL sensor is available for use in temperatures up to 80°C (remote mounting only) and detects gas concentrations up to 100% LEL of a target gas with a resolution in the region of 1% LEL, depending on the gas being detected. The sensor is available with ¾" NPT thread only.

High Temperature LEL version

The high temperature version is available for use in temperatures up to 150°C (remote mounting only) and detects gas concentrations up to 100% LEL of a target gas with a resolution in the region of 1% LEL, depending on the gas being detected. The sensor is available with ¾" NPT thread only.

Details of connecting these sensors with the Sensepoint XCD RFD transmitter are given in sections 5 and 6. For more sensor specific details, refer to the 705 Combustible Gas Sensor Operating Instructions Part No: 00705M5002.



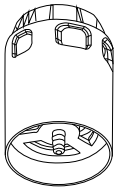
Standard LEL version

High Temperature LEL version

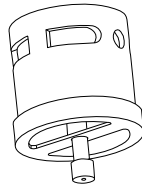
705 LEL flammable sensors

4.3 Accessories

A range of accessories are available to allow use of Sensepoint XCD RFD in a wide variety of applications. These include Pipe mounting bracket, Sunshade deluge cover, Sensor collecting cone, Sensor flow Housing and Remote sensor mounting junction boxes.



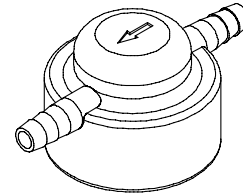
For Sensepoint XCD
(P/N: SPXCDWP)



For Sensepoint / 705
(P/N: 02000-A-1640/1635)

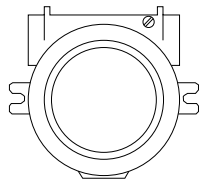
Standard Weather Protection

The Standard Weather Protection is designed to protect the sensor from changes in environmental conditions. This is recommended to be fitted to a Sensepoint XCD sensor and Sensepoint / 705 sensors.

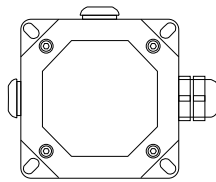


Calibration Cup

The Gassing Cap (P/N: S3KCAL) is an optional accessory that may be temporarily fitted to Sensepoint XCD flammable sensors for Gas Response checking during commissioning and routine maintenance.



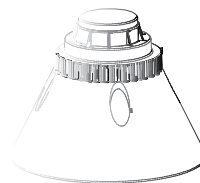
For UL/CSA Junction Box
(P/N: 2430-0021)



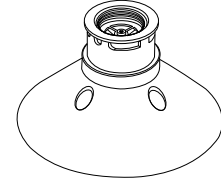
For ATEX Junction Box
(P/N: 00780-A-0100)

Remote Sensor Mounting

UL aluminum junction box, ATEX standard junction box and ATEX High temperature junction box (P/N: 2052D0001) are optional accessories that can be used for remote sensor mounting. Make the connection from the junction box to the transmitter using suitable cable and cable glands.



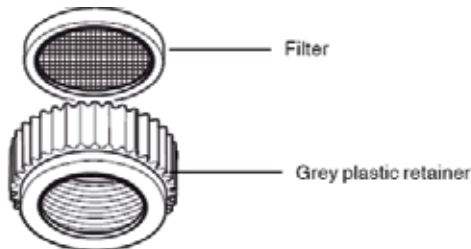
For Sensepoint XCD
(P/N: SPXCDCC)



For Sensepoint / 705
(P/N: 02000-A-1642)

Collecting Cone

The Collecting Cone is an optional accessory that may be fitted to the Weather Protection of XCD and Sensepoint / 705 sensors. The collecting cone is designed for use with gases that are lighter than air.



Sensepoint Filter and Filter Housing

Sensepoint Stainless steel filter (P/N: 00780-F-0018) and Filter Housing (P/N: 00780-C-0038) is an optional accessory can be used to offer additional protection to the Sinter in dry, and dusty applications.



Calibration Gas Flow Housing

The Calibration Gas Flow Housing (P/N: 02000-A-1645) may be used for either calibration of the Sensepoint / 705 sensor or if the Sensepoint / 705 sensor is to be used as part of a Aspirated Sampling System.

4.4 Options

4.4.1 Modbus®

One of the most common field buses in the industry, the optional Modbus® interface allows the XCD to connect to a bus of devices and transmit data to PLCs or controllers (see Appendix A). Connections to the XCD are made through a pluggable terminal block on the Modbus® interface circuit board. Modbus® RTU protocol uses ASCII/Hex protocols for communication. And allows all transmitter/sensor front panel functions to be transmitted using this industrial fieldbus.

Modbus® protocol is a Master-Slaves protocol. Only one master (at the same time) is connected to the bus and one or up to 32 slave nodes are also connected to the same serial bus. Modbus® communication is always initiated by the master. The slave nodes will never transmit data without receiving a request from the master node. The slave nodes will never communicate with each other. The master node initiates only one Modbus® transaction at the same time.

The MODBUS® may only be used for data collection or record keeping with regard to combustible gas detection and not for performance verification.

Modbus® option is available only for selected gases. Please refer to chapter 15 Ordering information.

To find out if a unit has the Modbus® option fitted, look at the part number on the product label. Units fitted with Modbus® have the letter “M” at the end of the part number.

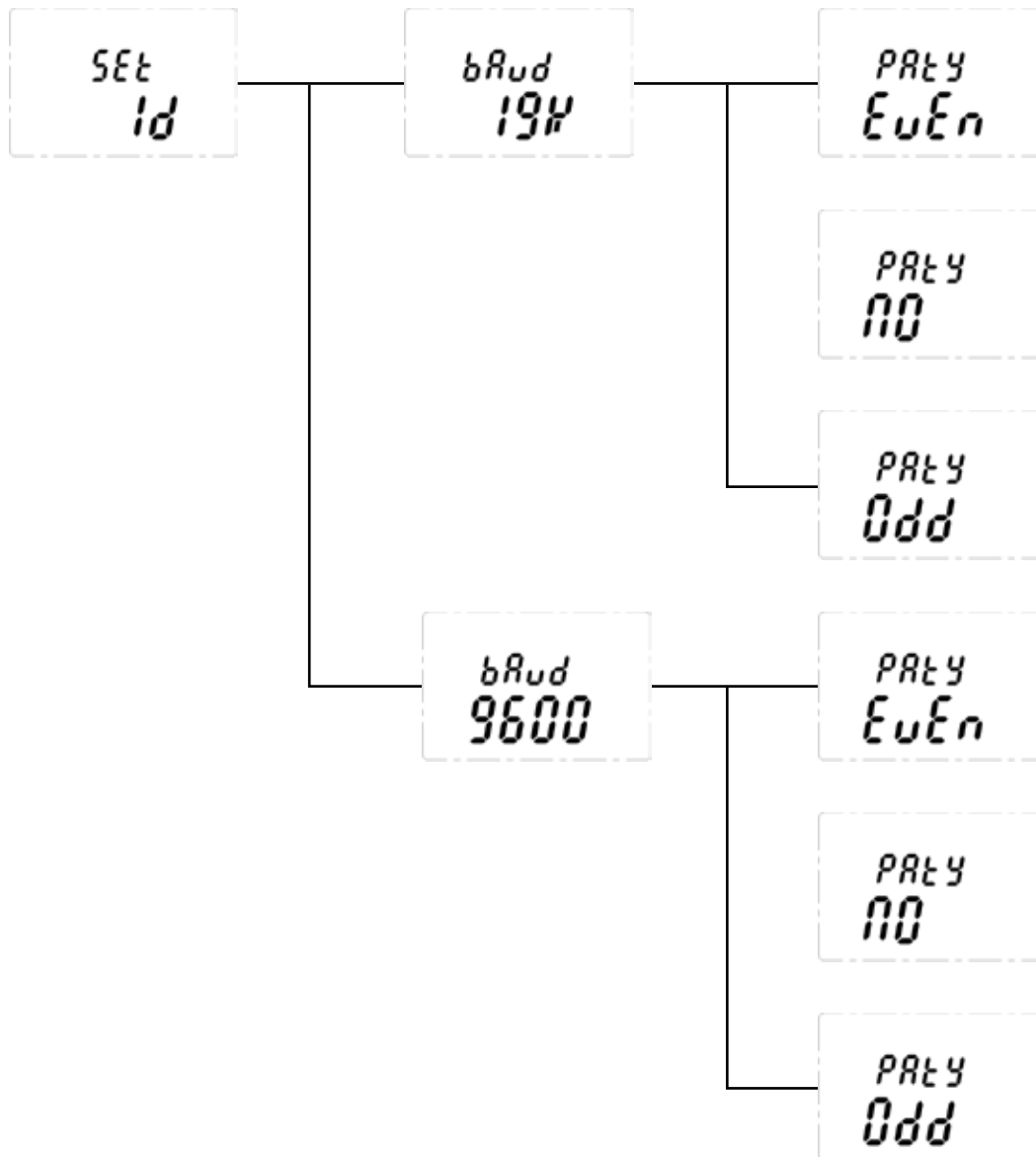
Note: MODBUS® is a registered trademark of Schneider Automation Inc.

(MODBUS ID SETTING)

Set id>>Set Modbus slave ID>>Set Baud rate>>Set Parity

- 1) Slave ID shall be set 1~247
- 2) Baud rate setting 9600 or 19200
- 3) Parity setting (No, Even, Odd)

From the Configuration Mode screen, select '✓'. To set the Modbus Slave ID, use the up-down '▲▼' switches to move to the desired position and use '✓' to select it. Again, using the '▲▼' switches, increment or decrement the value until the desired value appears, selects the value and moves to the next setting.



The communications baud rate and Parity Setting can also be set from this screen by using the '▲▼' switches to navigate to the baud rate display then selecting '✓'. Using the '▲▼' switches, highlight the proper baud rate or parity setting and select '✓'. Default is Slave ID 1, 19200bps and even parity.

Note: Set ID menu is available only for XCD equipped with Modbus® option.

5 Installation

Refer to the Sensepoint XCD RFD Control Drawing 3001EC091 for CSA applications shown in section 17.

WARNINGS

Sensepoint XCD RFD is designed for installation and use in Zone 1 or 2 hazardous areas in many countries including Europe, and for Class I, Division 1, Group B,C & D Hazardous Areas in the Americas.

Installation must be in accordance with the recognized standards of the appropriate authority in the country concerned.

Access to the interior of the detector, when carrying out any work, must only be conducted by trained personnel.

Before carrying out any work ensure local regulations and site procedures are followed. Appropriate standards must be followed to maintain the overall certification of the detector.

Care should be taken when removing and refitting the Sensepoint XCD plug-in Sensor to the Sensor Socket so that damage to the connection pins can be avoided.

If using an anti-seize compound, the threads should be thinly coated with an approved silicone free compound e.g. petroleum jelly

To reduce the risk of ignition of hazardous atmosphere, de-classify the area or disconnect the equipment from the supply circuit before opening the detector enclosure. Keep assembly tightly closed during operation.

Never attempt to open a junction box/enclosure or replace/refit the sensor in potentially hazardous atmospheres while power is still applied to the transmitter.

The detector must be earthed/grounded for electrical safety and to limit the effects of radio frequency interference. Earth/ground points are provided inside and outside the unit. Ensure that all screens/instrument earth/clean earth wiring is earthed/grounded at a single point (either at the controller or detector - BUT NOT BOTH) to prevent false alarms due to earth/ground loops.

Take care when handling sensors as they may contain corrosive solutions.

Do not tamper with or in any way disassemble the sensor.

Do not expose to temperatures outside the recommended ranges.

Do not expose sensors under storage conditions to organic solvents or flammable liquids.

Refer to the local or national regulations relative to the installation at the site. For Europe see EN60079-29-2, EN60079-14 and EN61241-14.

Only assessed for ATEX for ignition hazards.

This equipment is designed and constructed as to prevent ignition sources arising, even in the event of frequent disturbances or equipment operating faults. Note: The control card must have a suitably rated fuse.

The sensor head must be fitted with the supplied weather protection, and mounted so that the sinter is pointing downward to provide ingress protection IPX6.

The weather protection is a potential electrostatic charging hazard. The manufacturer's instructions should be observed.

The Sensepoint sensor is a possible Electrostatic risk - Do not rub or clean with solvents. Clean with a damp cloth. High velocity airflows and dusty environments can cause hazardous electrostatic charges.

5.1 Mounting and location

Caution: The location of gas detectors should be made in accordance with any relevant local and national legislation, standards or codes of practice. Always replace sensors with a sensor of the same type.

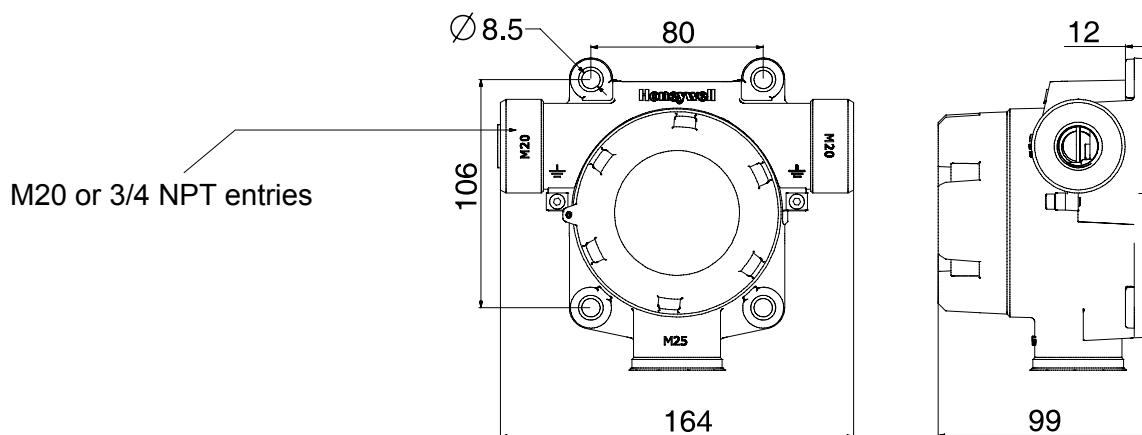
Gas detectors should be mounted where a potential hazard of gas is most likely to be present. The following points should be noted when locating gas sensors.

- When locating detectors consider the possible damage caused by natural events e.g. rain or flooding.
- Consider ease of access to the gas detector for functional testing and servicing.
- Consider how escaping gas may behave due to natural or forced air currents.

Note: The placement of gas detectors should be determined following the advice of experts having specialist knowledge of gas dispersion, experts having knowledge of the process plant system and equipment involved, safety and engineering personnel. The agreement reached on the location of detectors should be recorded.

5.2 Mounting the transmitter

The Sensepoint XCD RFD transmitter has an integral mounting plate consisting of four mounting holes on the transmitter body. The transmitter may be fixed directly to a surface mounting, or to a horizontal or vertical pipe/structure, 40.0-80.0mm (1.6 to 3.1 inches) in diameter/cross section. The Pipe Mounting Bracket accessory (optional accessory) may be used for this purpose.



All dimensions are shown in mm.

Diagram 5: Outline and mounting dimensions

5.3 Installing the sensor

WARNINGS

Care should be taken when removing and refitting the Sensepoint XCD plug-in Sensor to the Sensor Socket so that damage to the connection pins can be avoided.

*If using an anti-seize compound, the threads should be thinly coated with an approved silicone free compound e.g. petroleum jelly
Take care when handling old sensors as they may contain corrosive solutions.*

Take care when removing or replacing the Sensor Retainer as there may be sharp edges present on the adjoining threads.

The equipment is designed and constructed as to prevent ignition sources arising, even in the event of frequent disturbances or equipment operating faults.

Only assessed for ATEX for ignition hazards.

The sensor head must be fitted with the supplied weather protection, and mounted so that the sinter is pointing downward to provide ingress protection IPX6.

The weather protection is a potential electrostatic charging hazard. The manufacturer's instructions should be observed.

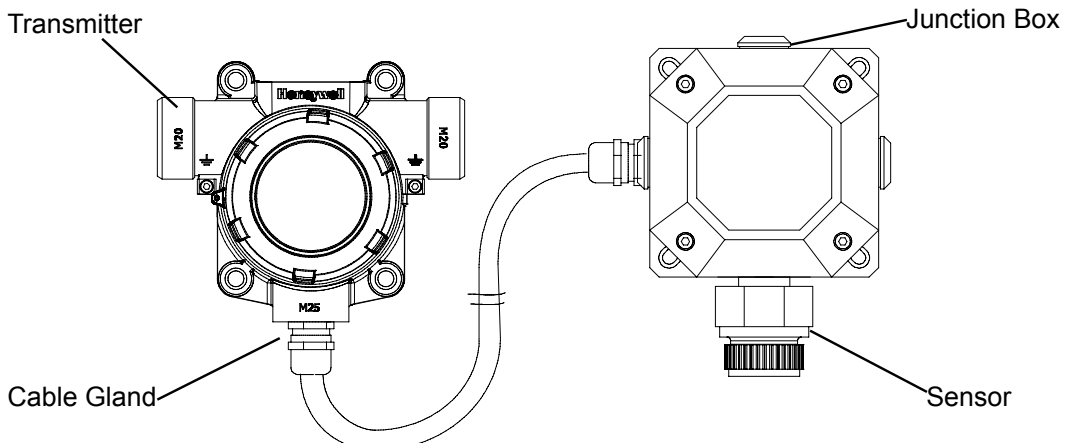
A remotely mounted sensor should be mounted using a suitable junction box . For further details regarding mounting sensors to suitable junction boxes refer to the relevant sensor manual.

1. Connect the remote sensor/junction box to the Sensepoint XCD RFD transmitter using suitable cable with wires of diameter 0.5 - 2.5mm² (20AWG - 13AWG).
2. Connect the cable to the transmitter enclosure via the bottom entry.
3. Cable (non conduit) based installations must use appropriately certified cable glands. Refer to the Sensepoint XCD RFD Control Drawing 3001EC091 shown in section 17 for conduit based installation in the Americas.

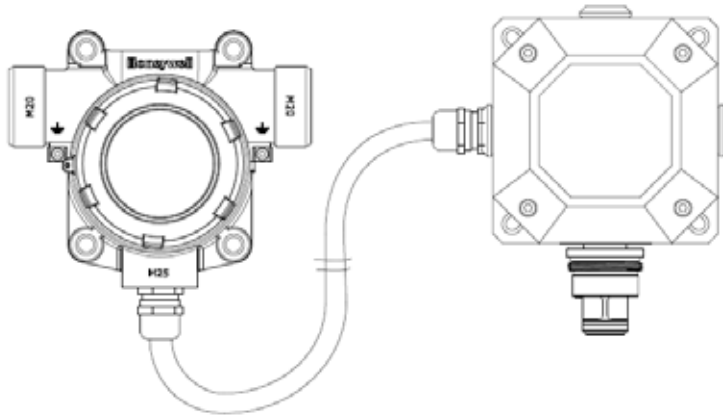
Note: The maximum cable length between the remotely mounted sensor and the Sensepoint XCD RFD transmitter is 30 meters (100 feet). The maximum loop resistance is 17 Ω.

4. Terminate the wires from the sensor in the transmitter as shown in chapter 6.2.
5. Select sensor type at configuration menu after remote sensor mounting. Refer to the chapter 12.1 Sensor Replacement and the chapter 13.3.1 Sensor Selection.

Sensepoint XCD RFD with Sensepoint Remote Sensor

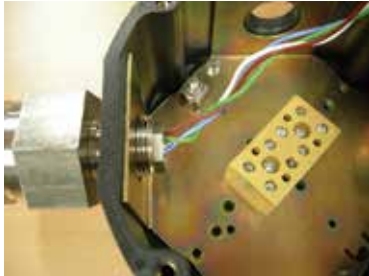


Sensepoint XCD RFD with Sensepoint XCD remote plug-in sensor



It is necessary to use a ferrite filter at the remote sensor to reduce electromagnetic interference. The ferrite filter (supplied) should be fitted as follows:

1. Screw the sensor into the remote junction box.
2. Open the ferrite filter.
3. Wind the sensor leads 2 turns round the ferrite filter.
4. Close the ferrite filter.
5. Follow instructions in the individual sensor manuals to complete installation.



6 Electrical connections

WARNINGS

Sensepoint XCD RFD is designed for installation and use in Zone 1 or 2 hazardous areas in many countries including Europe, and for Class I, Division 1, Group B,C & D Hazardous Areas in the Americas.

Installation must be in accordance with the recognized standards of the appropriate authority in the country concerned.

Access to the interior of the detector, when carrying out any work, must only be conducted by trained personnel.

Before carrying out any work ensure local regulations and site procedures are followed. Appropriate standards must be followed to maintain the overall certification of the detector.

Care should be taken when removing and refitting the Sensepoint XCD Sensor Cartridge to the Sensor Socket so that damage to the connection pins can be avoided.

If using an anti-seize compound, the threads should be thinly coated with an approved silicone free compound e.g. petroleum jelly

To reduce the risk of ignition of hazardous atmosphere, de-classify the area or disconnect the equipment from the supply circuit before opening the detector enclosure. Keep assembly tightly closed during operation.

Never attempt to open a junction box/enclosure or replace/refit the sensor in potentially hazardous atmospheres while power is still applied to the transmitter.

The detector must be earthed/grounded for electrical safety and to limit the effects of radio frequency interference. Earth/ground points are provided inside and outside the unit. Ensure that all screens/instrument earth/clean earth wiring is earthed/grounded at a single point (either at the controller or detector - BUT NOT BOTH) to prevent false alarms due to earth/ground loops.

Take care when handling sensors as they may contain corrosive solutions.

Do not tamper with or in any way disassemble the sensor.

Do not expose to temperatures outside the recommended ranges.

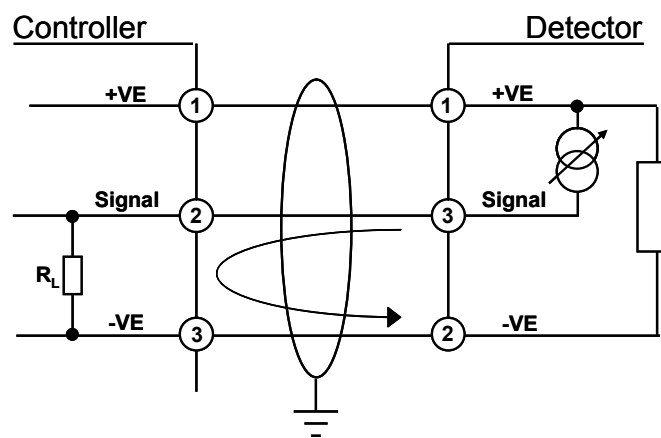
Do not expose sensors under storage conditions to organic solvents or flammable liquids.

Refer to the local or national regulations relative to the installation at the site. For Europe see EN60079-29-2, EN60079-14 and EN61241-14. For the Americas refer to the Sensepoint XCD RTD Control Drawing 3001EC091 shown in section 17.

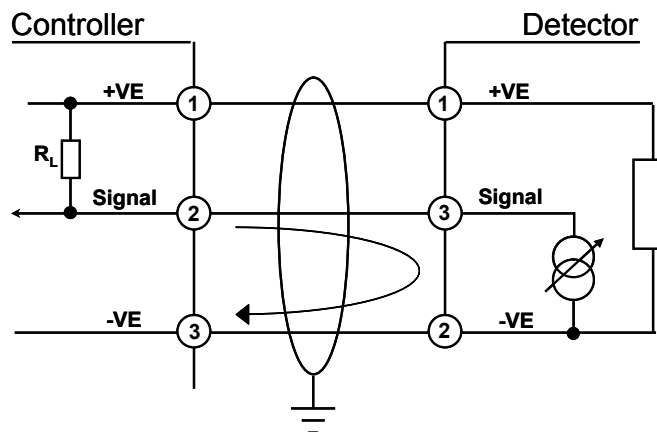
6.1 Transmitter Wiring

Caution: All electrical connections should be made in accordance with any relevant local or national legislation, standards or codes of practice.

The Sensepoint XCD RFD transmitter may be wired in either Current SOURCE or Current SINK configuration. These two options are offered to allow greater flexibility in the type of control system that it can be used with. SOURCE/SINK is selectable via the switch located on the back side of the display module; accessible by removing the display module during installation / commissioning (see section 9).



XCD Source 3 Wire 4-20mA (Source)



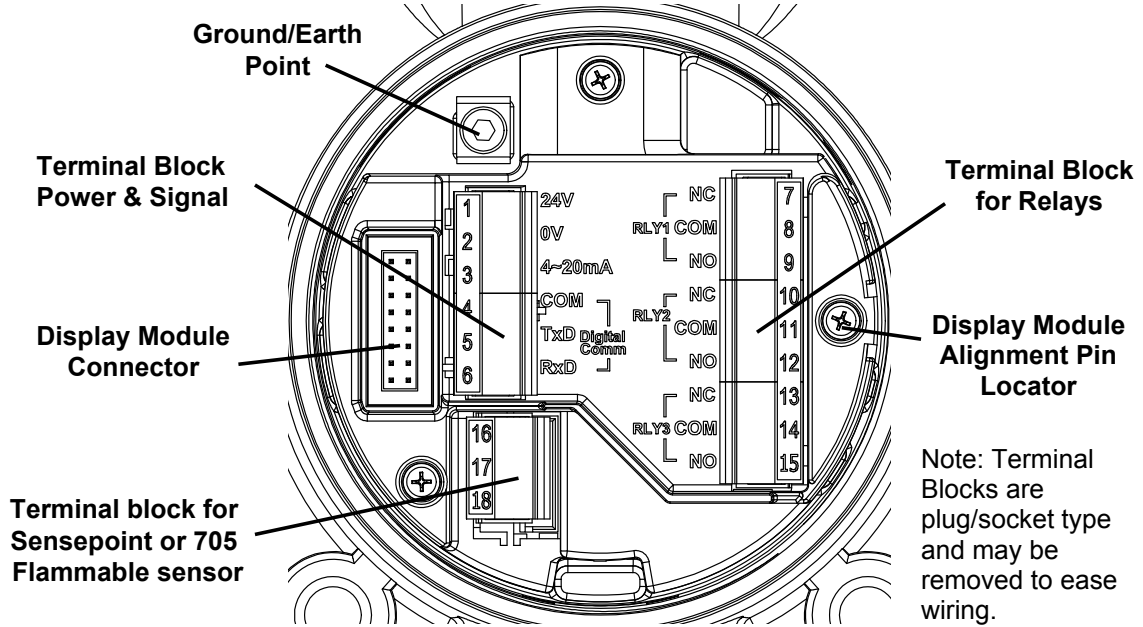
XCD Sink 3 Wire 4-20mA (Sink)

Note: Terminate cable screen at detector or controller, not both.

Caution: 250ohm load resistor (RL) is installed in the factory, In case of connection with controller, this resistor should be removed because controller has load resistor internally.

6.2 Terminal connections

Note: Ensure that none of the wires in the terminal area cause an obstruction when refitting the Display Module. Ensure that the socket on the Display Module is fully engaged in the Display Module Connector on the Terminal Module.



Note: Terminal Blocks are plug/socket type and may be removed to ease wiring.

Diagram 6: Sensepoint XCD RFD Terminal module

Terminal Module Connections			
Terminal Number	Marking	Connection	Description
1	24V	+VE Supply(12-32VDC)	Controller Connections
2	0V	-VE Supply(0VDC)	
3	4~20mA	Current Output Signal	
4	COM	Common	
5	TxD	MODBUS A(+)	MODBUS RTU. RS485 (Optional)
6	RxD	MODBUS A(-)	
7	RLY1/NC	Normally Closed	Programmable Relay 1 (Default A1)
8	RLY1/COM	Common	
9	RLY1/NO	Normally Open	
10	RLY2/NC	Normally Closed	Programmable Relay 2 (Default A2)
11	RLY2/COM	Common	
12	RLY2/NO	Normally Open	
13	RLY3/NC	Normally Closed	Programmable Relay 3 (Default Fault)
14	RLY3/COM	Common	
15	RLY3/NO	Normally Open	
16	+VE	Sensitive (Sensor Brown Wire)	RFD Sensor Connection
17	-VE	Non-Sensitive (Sensor Blue Wire)	
18	01	Signal (Sensor White Wire)	

Table 1: Transmitter terminal connections

Note: The Sensepoint HT sensor and 705 HT sensor (not covered by the CSA certification) must be earthed either at the remote junction box or at the transmitter as appropriate. Avoid earth loops.

6.3 Power for UL/CSA Version

The Sensepoint XCD transmitter(UL/CSA versions)requires a power supply from the controller of between 12Vdc and 32Vdc. Ensure that a minimum supply of 12Vdc is measured at the sensor, taking into account the voltage drop due to cable resistance.

The maximum loop resistance in the field cable is calculated as follows

$$R_{loop} = (V_{controller} - V_{detector\ min}) / I_{detector}$$

Example;

The controller is supplying a nominal 24Vdc ($V_{controller}$), the detector minimum allowable voltage is 12Vdc ($V_{detector\ min}$), therefore the maximum allowable voltage drop between the controller and detector is 12Vdc; this means a voltage drop of 6V in each core (+ve core and -ve core).

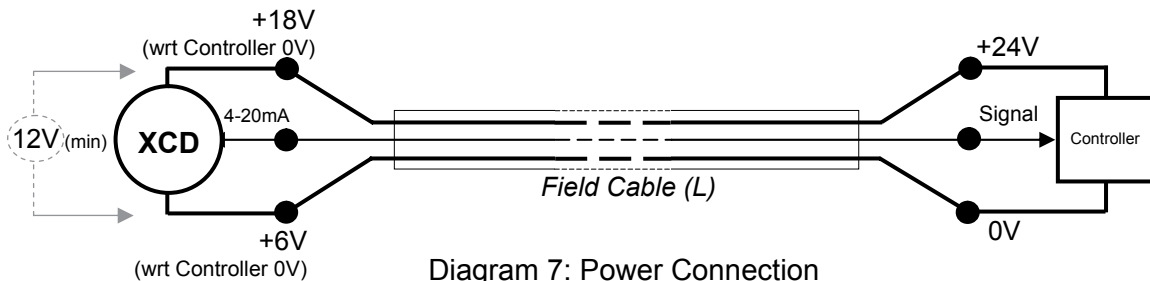


Diagram 7: Power Connection

Power consumption of the detector is 5.0W. The current required to drive the detector at the minimum voltage is ($I = P / V$), $5.0 / 12 = 416.7$ mA ($I_{detector}$).

So, the maximum ieldcable loop resistance (R_{loop}) = $12 / 0.42 = 28.8$ Ohms, or 14.4 Ohms per core, (allowing for component variations, losses, etc.).

The following tables show the maximum cable distances between the controller and transmitter assuming a voltage drop of 4V in each core and for different cable parameters. The tables are examples only and actual cable parameters and source power supply voltage for the application should be used to calculate the maximum cable distance allowed at the installation site.

Typical cable data		Maximum Cable length (L)	
Cable size (cross sectional area)	Cable resistance Ω /km (Ω /mi)	Meters	Feet
0.5mm ² (20AWG*)	36.8 (59.2)	353	1158
1.0mm ² (17AWG*)	19.5 (31.4)	666	2185
1.5mm ² (16AWG*)	12.7 (20.4)	1023	3356
2.0mm ² (14AWG*)	10.1 (16.3)	1287	4222
2.5mm ² (13AWG*)	8.0 (12.9)	1621	5318
*nearest equivalent	**example for 24Vdc supply voltage		

Table 2: Maximum cable distances

6.4 Cabling

The use of industrial grade, suitably armoured field cable is recommended.

For example, screened 3 cores (plus screen 90% coverage), suitably mechanically protected copper cable with a suitable M20 explosion-proof gland with 0.5 to 2.5 mm² (20 to 13 AWG) conductors. Ensure the cable gland is installed correctly and fully tightened. All unused cable entries must be sealed with a suitable certified sealing plug (one plug is supplied).

Remote Mounting Cable Details

Type	Cable Spec	Max Length
RFD Remote	AWM2464 AWG20~AWG14 Shield	30meters

Note: The Sensepoint HT sensor requires an earth core if the remote junction box does not have a suitable earth point.

6.5 Cable and Earth/Ground regimes

Effective Earth/Ground bonding is important to ensure good EMC and RFI immunity.

The following diagrams show examples of how to earth/ground bond the cable at enclosures. These bonding techniques provide good RFI/EMC performance. Earth/ground loops must be avoided to prevent the risk of false signal variation.

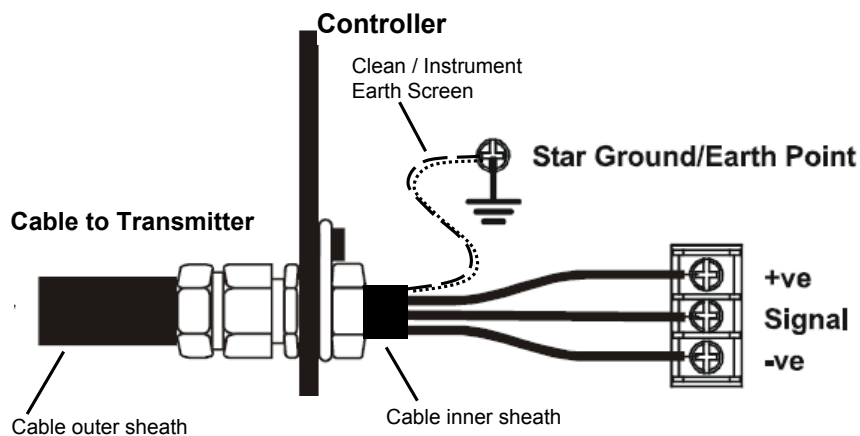


Diagram 8: Controller Grounding

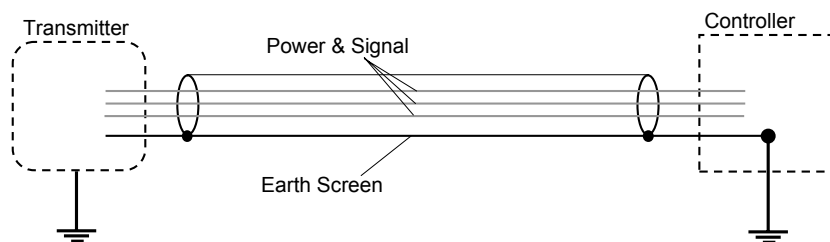
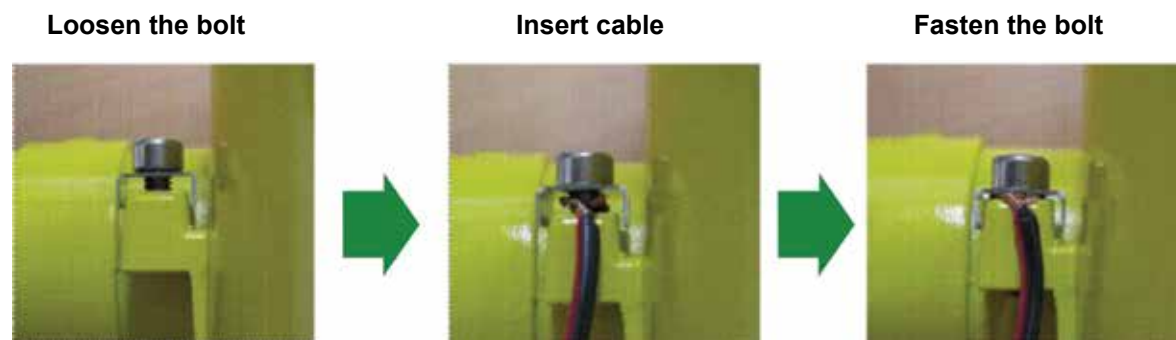


Diagram 9: System grounding

The Earth Screen of the field cable should be “tied to Earth” or connected to Ground at one point only. It is common practise to adopt a STAR EARTH connection regime where all instrumentation Screens are connected at one common point.

The Screen at the other end of the cable should be “parked” or terminated into a blank terminal.

The following diagrams show how to install the wire into the ground screw of the enclosure.



6.6 Ground Terminal Wiring

Internal Ground connection: Utilize the shield of the wiring cable recommended in the wiring instructions. For connection to this terminal. Twist the shield wire to avoid stray shield wires, Loosen the screw sufficiently and wrap the wire around the screw in a “U” shape. Raise the clamp and place the wire between the clamp and ground base, lower the clamp and tighten the screw to 6.9lb-in torque.

External Ground Connection: If required by local authority, Utilize a No 14 AWG copper, (Stranded or Solid), wire. Loosen the screw sufficiently to enable ‘wrapping the wire around the screw in a “U” shape. Raise the clamp and place the wire between the clamp and ground base, lower the clamp and tighten the screw to 10.4lb-in torque. A suitable Ring or Spade type insulated crimp terminal may also be used to accommodate the M4 size external earth screw.

7 Default configuration

The Sensepoint XCD RFD transmitter is supplied with the following default configuration.

Function	Value/Setting	Meaning
Sensor Type	Automatic for Sensepoint XCD RFD sensors. Must be set for Sensepoint and 705 sensors.	XCD RFD recognizes the XCD RFD sensor cartridge according to the gas type within its own sensor family i.e. mV. For a Sensepoint and 705 sensor the user must set the sensor type.
Signal output	≥0.0<1.0 mA	Fault (refer to table 9 section 12.3 for details)
	2.0 mA or 4.0 mA	Inhibit (during configuration/user settings)
	4.0 mA to 20.0 mA	Normal gas measurement
	22.0 mA	Maximum over range
Alarm Relay 1*	Value is sensor dependant	Lower alarm level
	De-energized	Energizes on alarm
	Contact Normally Open (NO)	Closes on alarm
Alarm Relay 2*	Value is sensor dependant	Higher alarm level
	De-energized	Energizes on alarm
	Contact Normally Open (NO)	Closes on alarm
Fault Relay	<1mA	Detector Fault
	Energized	De-energizes on alarm
	Contact Normally Open (NO)	Closes on alarm
Inhibit	2.0 mA (default)	Signal output inhibited during menu use If any relay is set to inhibit relay, then inhibit relay will be activated.
Timeout	Disabled	No inhibit timeout. The detector waits for a button press before returning to the previous state/setting Timeout period can be set in 'Configure Inhibit' menu in Configuration Mode.
Password	0000 (Disabled)	0000 (Password disabled). If changed then password is activated.
Location (Tag Number)	0000	Optional feature to identify the location or User's "Tag" number of the XCD
Temperature	°C	Option to have °C or °F
Modbus	ID, baud rates and Parity bit	ID : 1 Baud rates : 19,200 Parity bit : EVEN

* Alarm relays automatically reset when reading falls within alarm thresholds. If relay configured to LATCH, then relays must be reset using the Magnetic Wand.

Table 3: Default configuration

Gas Name	Default Range	Lower Alarm	Lower Alarm Type	Higher Alarm	Higher Alarm Type
Sensepoint Flammable	100%LEL	20%LEL	Rising	40%LEL	Rising
Sensepoint HT Flammable	100%LEL	20%LEL	Rising	40%LEL	Rising
Sensepoint HT Flammable	20%LEL	10%LEL	Rising	15%LEL	Rising
705 Flammable	100%LEL	20%LEL	Rising	40%LEL	Rising
705 HT Flammable	100%LEL	20%LEL	Rising	40%LEL	Rising
XCD Flammable CB*	100%LEL	20%LEL	Rising	40%LEL	Rising
XCD Methane IR	100%LEL	20%LEL	Rising	40%LEL	Rising
XCD Propane IR*	100%LEL	20%LEL	Rising	40%LEL	Rising
Carbon Dioxide*	2.00%Vol	0.40%Vol	Rising	0.80%Vol	Rising

*Contact Honeywell Analytics for availability

For details of how to change the configuration of the Sensepoint XCD please refer to section 13.

8 Normal Operation

Sensepoint XCD RFD is supplied configured and ready for use according to the “Default Settings” table shown above. However these setting may be tailored to a specific application requirement using the Sensepoint XCD RFD configuration menu system.

Access to the Sensepoint XCD RFD transmitter’s configuration menus system is via the Magnetic Activation Tool.

8.1 Display Screen

The Sensepoint XCD RFD display features an LCD with Numeric and bar-graph gas concentration data, alpha-numeric warning and status indication, a target for magnetic switch activation and the UP/DOWN/ESC/ENTER zones for remote configuration. The LCD is also backlit with hi-intensity multi-colour LED indicator to show NORMAL, ALARM and FAULT status.

During normal operation the instrument display shows a steady GREEN backlight.

During Low and High Gas Alarm it displays a flashing RED backlight

During Fault condition the instrument display shows a flashing YELLOW backlight.

The screen is visible through the window of the transmitter’s cover. The display shows the gas concentration (both graphically and numerically), range, units, alarm/ fault status, etc.

Note: The detector display may become sluggish in sub-zero temperatures and possibly unclear at temperatures below -40 °C, but the detector continues its gas monitoring function. The display is not damaged and recovers when the temperature increases.

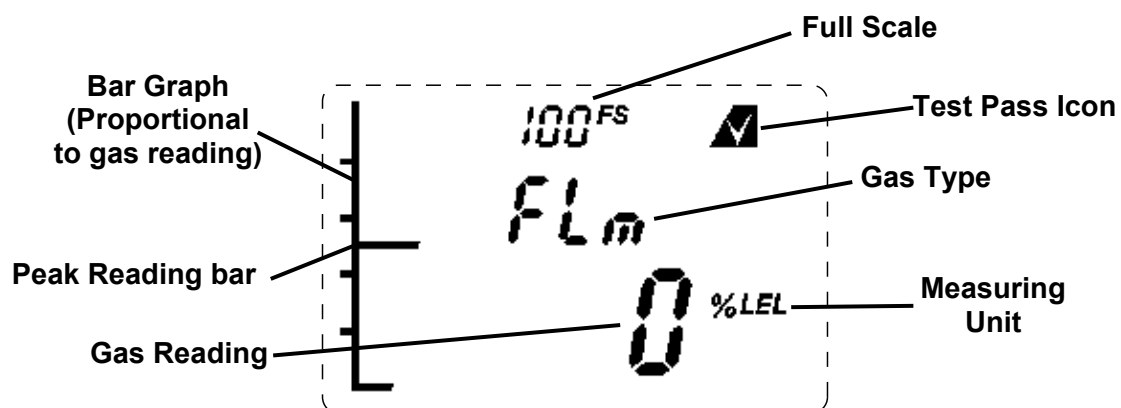


Diagram 10: Example of a Flammable Transmitter Display screen – Normal Operation

8.2 System Status

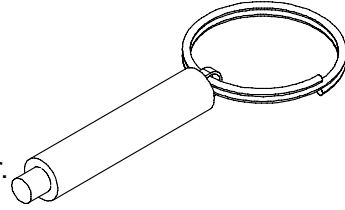
Display indications, current output and relay states for various operational conditions are shown in the following table. For further details of error messages and trouble shooting see section 12.3.

System Status						
Status	Display	Current Output	Relay			Back Light
			A1	A2	Fault	
Fault: Circuit or sensor error	F-XX fault number with fault icon blinking	0-1.0 mA			✓	Yellow, flashing
System Fault	N/A	0-0.15mA				
Note: In the event of processor failure the watchdog will automatically reset the system for recovery.						
Warning	W-XX warning number with fault icon blinking	Dependent on system status				Green Steady
Normal	0.0 Gas concentration	4-20 mA				Green Steady
Alarm 1	Gas concentration. 1 st alarm icon blinking	4-20 mA	✓			Red, flashing
Alarm 2	Gas concentration. 2 nd alarm icon blinking	4-20 mA	✓	✓		Red, flashing
Over-range	Full scale icon and reading blinking	22mA	✓	✓		Red, flashing
Inhibit	Inhibit icon dependent on Menu command. If any relay is set to inhibit relay, then inhibit relay will be activated.	2 or 4mA depending on configuration.				Green Steady

Table 4: System status

8.3 Magnetic Wand Activation

The magnetic wand is used as a tool to allow the user to communicate with the Sensepoint XCD RFD transmitter. Communication with the XCD RFD is achieved by positioning the Magnetic Wand at one of three different positions on the front glass window of the Sensepoint XCD RFD transmitter. Activation of the switches is verified by observing the Magnetic Wand Activation Icon on the LCD display



Hold the Magnetic Wand in position for up to 2 seconds = ●

Hold the Magnetic Wand in position for 3 seconds or more = ⊙



8.4 Operation Mode Structure

Sensepoint XCD RFD has 3 operating modes.

1. **Monitoring mode**, is the normal operating status while XCD RFD measures and displays gas concentration. The fault/warning status is periodically checked, relay contacts are activated according to the configuration.
2. **Configuration mode**, this mode allows parameters relating to the configuration of the Transmitter functions to be changed according to specific needs. This mode can be protected by a password mechanism to prevent unauthorised changes being made.
3. **Review mode**, allows the user to view the current configuration settings.

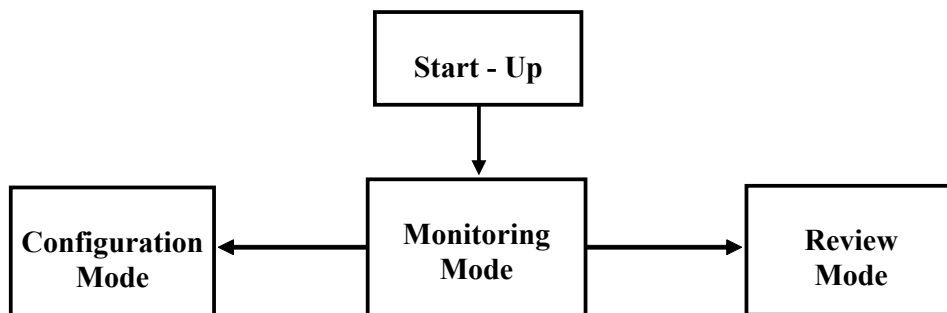


Diagram 11: Mode Structure

Further details of the information available and configuration options for the Sensepoint XCD RFD can be found in Section 13. of this manual.

9 First time switch on (Commissioning)

WARNING

The following procedure requires the Transmitter Cover to be removed while carrying out supply voltage checks. Therefore the appropriate permits to work should be sought in preparation.

Prior to carrying out any HOT WORK ensure local and site procedures are followed. Ensure that the associated control panel output actuation is inhibited so as to prevent false alarms.

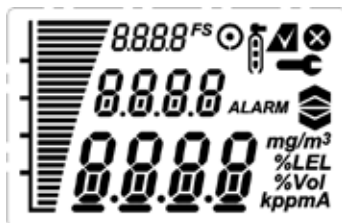
Caution: The following procedure should be followed carefully and only performed by suitably trained personnel

Note: Calibration is mandatory before the detector can be used for gas monitoring. Refer to Section 10.1 Calibration for the proper procedure.

1. Remove the transmitter housing cover and detach the display unit by lifting the semi-circular handle and pulling the assembly directly away from the termination module (without twisting it)
2. Configure the detector's analogue output signal configuration for Current SINK or Current SOURCE operation using the selector switch located on the back of the display module. The default setting is Current SOURCE.
3. Check that all electrical connections are terminated correctly as per section 6.
4. **Switch On** the external power supply to the transmitter at the safe area gas detection controller (or PLC).
5. Using a Digital Multi Meter (DMM), check the Supply Voltage at the terminals 1 (24V) and 2 (0V), this should be a minimum supply voltage of 12Vdc (Maximum supply voltage is 32V DC)
6. **Switch Off** the external power to the detector.
7. Refit the Display Module and Cover.

Note: Ensure that none of the wires in the terminal area cause an obstruction when refitting the Display Module. Ensure that the socket on the Display Module is fully engaged in the Display Module Connector on the Terminal Module.

8. **Switch On** external power to the detector.
9. All the display icons/text/numbers are displayed for 3 seconds.



10. A start up sequence will then be displayed, similar to the one shown in Diagram 15.

Note:

For a full description of each screen shown in Diagram 12, please refer to Section 13.3 “Review Mode” of this Manual.

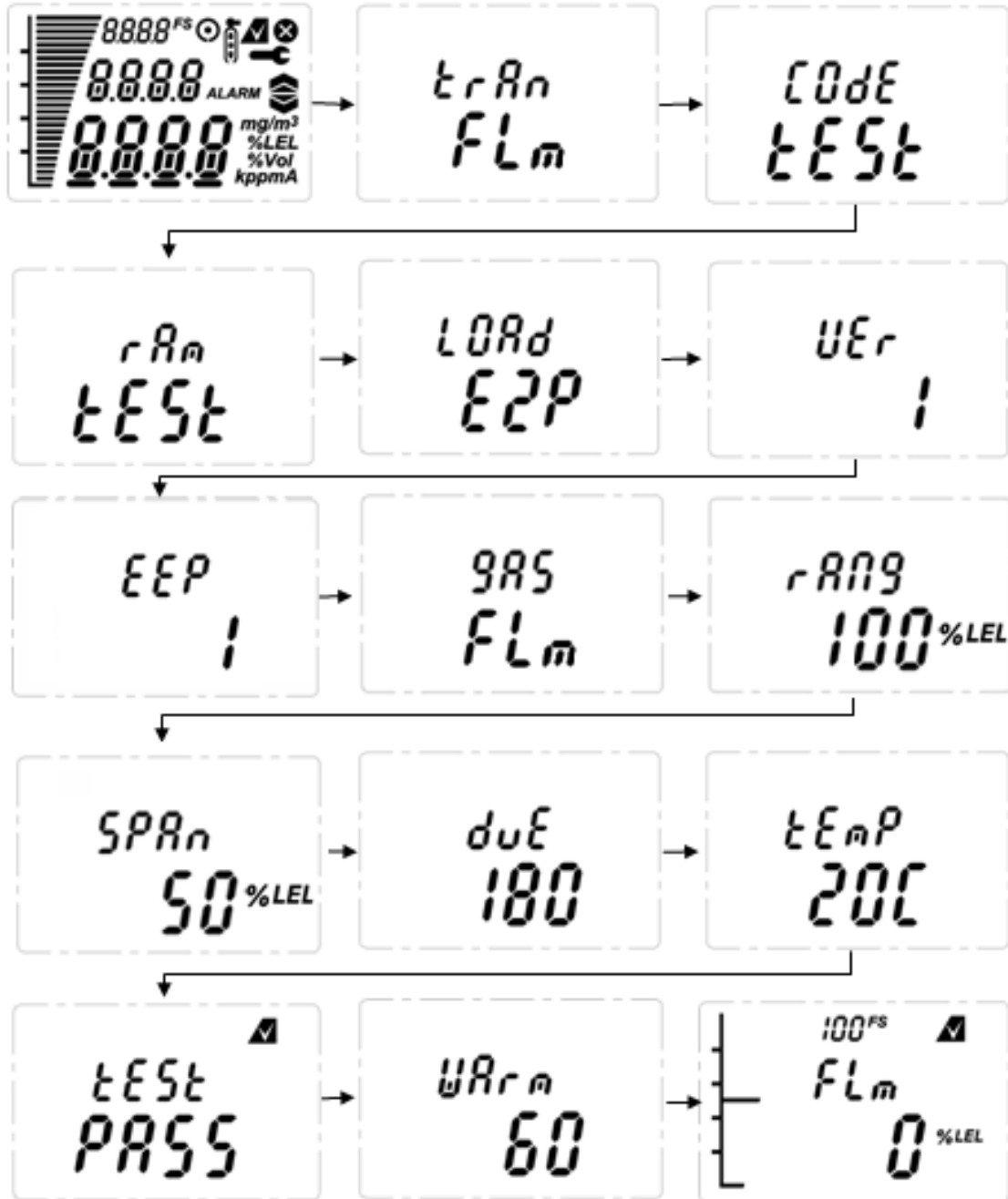


Diagram 12: Normal Start up procedure (For the Flammable sensor version)

11. The warm up countdown of 60 seconds (depending on the gas type) is then initiated.
12. Normal **Monitoring Mode** is then resumed.

10 Response Check and Calibration

CAUTION: Before each day's usage, sensitivity must be tested on a known concentration of methane equivalent to 25-50% of full scale concentration. Accuracy must be within 0-20% of actual. Accuracy may be corrected by calibrating the equipment.

It is recommended to periodically carry out a gas response check on the Sensepoint XCD RFD to ensure correct operation. This may be done in two ways;

1. A simple Response Check often referred to as a "BUMP TEST" is a test using calibration gas applied to the sensor via the nozzle of the Weather Protection or using the Sensepoint XCD RFD Gassing Cap.

If a BUMP TEST is done via the Weather Protection nozzle it may be necessary in windy conditions to increase the flow rate of the test gas by a further 1 LPM, OR, to shelter the weather protection from the wind.

2. A full gas calibration of the sensor as described in the following section, using ONLY the Sensepoint XCD Gassing Cap (Part No.: SPXCDDCAL) for the Sensepoint XCD sensor, or, using ONLY the Sensepoint Calibration Gas Flow Housing (P/N: 02000-A-1645) for the Sensepoint and 705 sensor.

10.1 Zeroing and span calibration

Caution: Before initial calibration allow the detector to stabilize for 30 minutes after applying power.

When in zeroing and span calibration mode the current output from the detector is inhibited (default 2mA) to avoid false alarms.

For Flammable gas calibration use a calibration gas concentration of 50%LEL +/-10% for Canada and US applications and between 25% and 95%LEL for other applications to ensure that the required accuracy can be attained.

HIGH OFF SCALE READINGS MAY INDICATE AN EXPLOSIVE CONCENTRATION.

To calibrate the detector, use an appropriate span gas cylinder, constant flow regulator AND the Sensepoint XCD Gassing Cap (see section 4.3). The flow rates used for calibration gas are as follows:

Gas Type	Flow rate (L / Min)
Flammable	1 to 1.5
Flammable IR	0.4 to 0.6

A compressed air cylinder (20.9%Vol oxygen) should be used to perform the zero calibration if the area where the detector is located contains any residual amount of the target gas. If no residual gas is present then the background air can be used to perform the zero calibration. Contact your Honeywell Analytics representative for details of suitable calibration kits.

To calibrate the detector follow the procedure below.

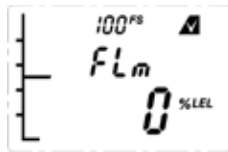
(ZERO CALIBRATION)**WARNING**

When calibrating the Sensepoint XCD Flammable IR or CO₂ IR sensors, it is essential that the zero calibration is always followed by a span calibration. The zero calibration must never be done alone.

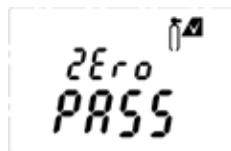
1. If the ambient air is NOT considered reliable to use to set the ZERO, then remove the weather protection and fit the Gassing Cap accessory (see Section 4.3) onto the sensor and apply a clean source of zero gas or compressed air.
2. To access the calibration menu, hold the end of the magnet over the switch located at the top center of the detector display (✓) for at least 3 seconds and then remove.
3. The display will indicate the first configuration mode menu 'SEt CAL'.



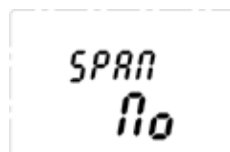
4. Put the magnet over the '✓' switch again and move to enter the Calibration menu.
5. The display will show the current gas reading, and the 'fl' icon flashes.



6. When the zero gas reading is stable use '✓' to confirm zero calibration.
7. If successful the display shows 'ZEro PASS' (if not successful, the display shows 'ZEro FAIL' and returns to configuration mode).



8. If using zero-air, turn it off. Zeroing is complete and saved.
9. The display shows 'SPAN' with 'YES' flashing.



10. If span calibration is required use '✓' proceed to the next step. If span calibration is not required, use '▲▼' to select 'No' and '✓' to return to configuration mode.

WARNING

When calibrating the Flammable IR or CO₂ IR sensors, it is essential that the span calibration is done after a zero calibration.

(SPAN CALIBRATION)

11. The display shows the current calibration span gas concentration while flashing the 'i' icon. Use '▲▼' to change the calibration span gas concentration, and '✓' when required span calibration level is set.



12. The display will show the current gas reading, and the 'i' icon flashes.

13. Connect the regulator to the span gas cylinder.

14. Apply the span gas to the sensor using the Sensepoint XCD Gassing Cap (see section 4.7 for description). The live gas reading is displayed. When the reading is stable, use '✓' to confirm span calibration.



15. If the sensor has been replaced the following display may be shown.



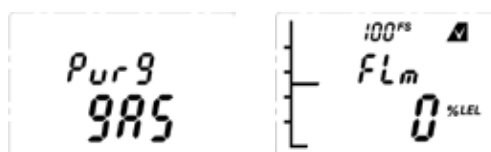
16. Use '▲▼' to select 'YES' if the sensor has been replaced or 'No' if it has not been replaced.

17. If the span calibration is successful the instrument will briefly display 'SPAN PASS' (if fails 'SPAN FAIL' displayed and returns to configuration mode).

Note: the calibration due warning counter is reset after a successful calibration. See section 12.3 for further details of setting a calibration due warning.

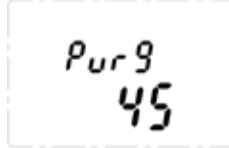


18. The display alternates between "Purg gAS" and the gas reading to indicate that the unit is expecting the span gas to be removed from the sensor.



19. Promptly switch off the calibration span gas and remove the Sensepoint XCD Gassing Cap from the sensor to allow the gas to disperse.

20. When the reading falls below 50% of the calibration gas level the display indicates a countdown .



21. When the countdown is finished, the calibration procedure is complete.

22. The instrument returns to the 'Set CAL' menu. Activate the '▲' or '▼' switch to select another menu or select 'Quit' to return to normal monitoring mode.



Note: Remember to always replace the Weather Protection and other accessories.

11 General Maintenance

WARNINGS

Access to the interior of the transmitter, when carrying out any work, must only be conducted by trained personnel.

Care should be taken when removing and refitting the Sensepoint XCD plug-in Sensor Cartridge to the Sensor Socket so that damage to the connection pins can be avoided.

Before carrying out any work ensure local regulations and site procedures are followed. Appropriate standards must be followed to maintain the overall certification of the sensor and transmitter.

To reduce the risk of ignition of hazardous atmosphere, de-classify the area or disconnect the equipment from the supply circuit before opening the transmitter enclosure. Keep assembly tightly closed during operation.

Never attempt to open a junction box/enclosure or replace/refit the sensor in potentially hazardous atmospheres.

Take care when handling sensors as they may contain corrosive solutions.

Do not tamper with or in any way disassemble the sensor.

Do not expose to temperatures outside the recommended ranges.

Do not expose sensors under storage conditions to organic solvents or flammable liquids.

The Sensepoint sensor is a possible Electrostatic risk - Do not rub or clean with solvents. Clean with a damp cloth. High velocity airflows and dusty environments can cause hazardous electrostatic charges.

For remote Flammable sensors used with the XCD RFD Transmitter, please refer to the individual sensor manual for specific recommended calibration periods.

11.1 Operational Life

The equipment should be checked following exposure to known contaminants, and recalibrated if necessary.

The pellistors used in the Catalytic flammable gas sensor can suffer from a loss of sensitivity when in the presence of poisons or inhibitors, e.g. silicones, sulphides, chlorine, lead or halogenated hydrocarbons. The pellistors are poison resistant to maximize the operational life of the Catalytic flammable sensor. A typical operating life, subject to the presence of poisons/inhibitors is 36 months.

The NDIR (infrared) flammable gas sensor is not affected by the above-mentioned poisons and therefore has a longer life span. A typical operating life is 5 years.

Refer to section 12 for sensor replacement procedures.

12 Servicing

WARNINGS

Take care when handling sensors as they may contain corrosive solutions. Do not tamper or in any way dis-assemble the sensor. Do not expose to temperatures outside the recommended range. Do not expose sensor to organic solvents or flammable liquids.

Care should be taken when removing and refitting the Sensepoint XCD plug-in Sensor Cartridge to the Sensor Socket so that damage to the connection pins can be avoided.

*Caution: The following procedure should be followed carefully and only performed by suitably trained personnel.
A fault condition will be signalled by the detector if the sensor is removed with the unit under power.*

12.1 Sensor replacement

The sensors that are used with the Sensepoint XCD RFD have no serviceable parts. When they have reached the end of their operational life, simply replace the sensor or the sensor cartridge.

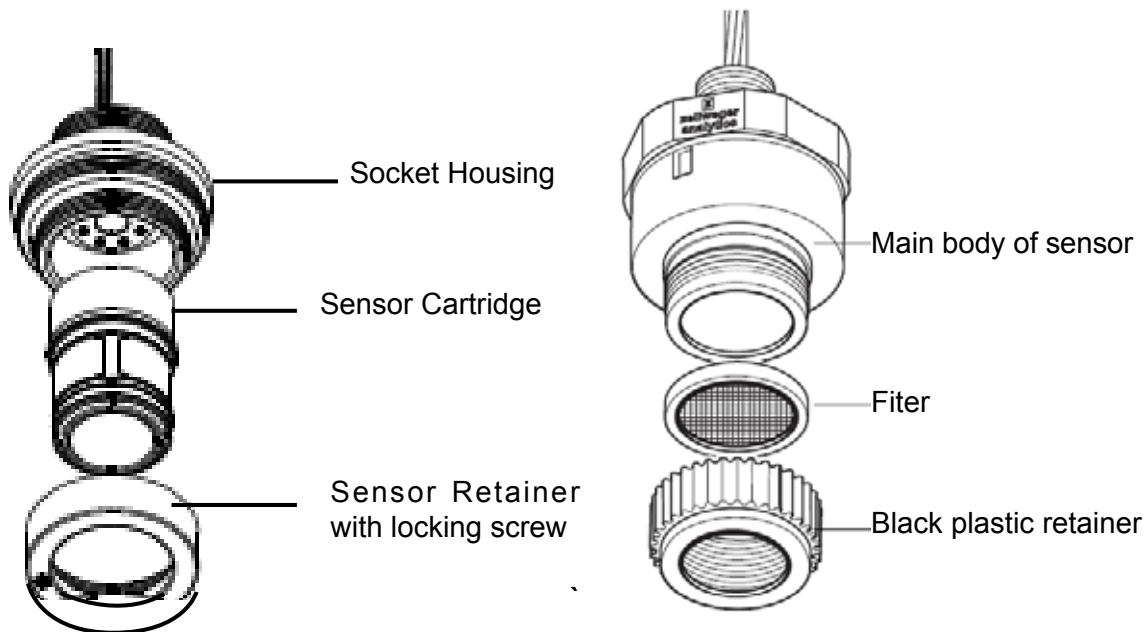


Diagram 13: Sensor Replacement

Only a qualified installation engineer should service the sensor. Ensure power is off before carrying out any maintenance procedures. The only maintenance required is sensor replacement and filter changing (if fitted to an accessory). To replace the complete sensor refer to the Quick Start Guide of Sensepoint XCD Remote Cartridge (PN: 3001M5022_1).

To replace remote sensor of a Sensepoint XCD Flammable Sensor Socket use the following procedure:

1. **Important:** Remove the Power from the Sensepoint XCD RFD Transmitter
2. Remove other accessories from the sensor socket thread.
3. Remove the Sensor Retainer with locking screw.
4. Remove the old Sensor Cartridge and replace with a fresh Sensor Cartridge.
5. Screw the accessory firmly onto the sensor until it seats against the sensor body hexagon.
6. After fitting the new sensor, reapply power to the XCD RFD transmitter.

Note: It is possible that an F04 fault message may show on the XCD RFD display if the new replacement sensor type does not exactly match with the original sensor it is replacing. In this case, select sensor type from the Configuration menu. Please refer to section 13.3.1 Sensor Selection. Remove the F04 fault message by entering review mode. Refer to section 13.4. Review mode.

7. Select sensor type at configuration menu after remote sensor mounting. Refer to the chapter 13.3.1 Sensor Selection.
8. And then remove fault message by entering review mode. Refer to the chapter 13.4. Review mode.

WARNING

Ensure that the same Gas Type and Range of Sensor is fitted in place of the old Sensor.

Care should be taken when removing and refitting the Sensepoint XCD plug-in Sensor Cartridge to the Sensor Socket so that damage to the connection pins can be avoided.

The sensor head must be fitted with the supplied weather protection, and mounted so that the sinter is pointing downward to provide ingress protection IPX6.

The weather protection is a potential electrostatic charging hazard. The manufacturer's instructions should be observed.

CAUTION

The 4-20mA analogue output signal will remain INHIBITED at 2mA (default setting) while the XCD RFD remains in Configuration Mode. However, the ALARM and FAULT RELAYS remain Active.

Changing the configuration of the Sensor Type or the Gas Star Rating for catalytic sensors may result in temporary activation of the ALARM or FAULT RELAYS. Should this occur, then recalibrating the sensor will return the XCD RFD to normal condition and reset the relays.

As a precaution, please take necessary action to manually inhibit any external actuator or alarm devices that are connected to the XCD RFD Alarm/Fault Relays to prevent unnecessary activation during commissioning or reconfiguration of the XCD RFD gas detector.

To replace the Sensepoint LEL sensor please refer to the Sensepoint Technical Handbook Part No. 2106M0502

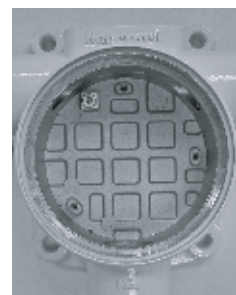
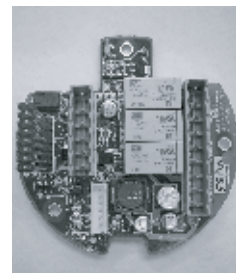
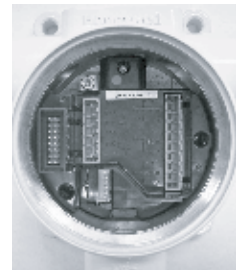
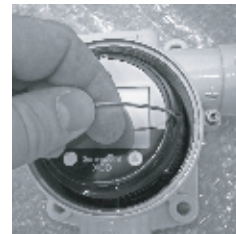
12.2 Replacing Modules within the Transmitter

Two replaceable module assemblies are located within the transmitter housing. The Display Module and the Terminal Module.

The Display Module is simply removed by unplugging it from the Terminal Module (this procedure is done during normal installation).

To replace the Terminal Module, use the following procedure:

1. Unscrew and remove the Transmitter Cover
2. Lift the handle and un-plug and remove the Display Module.
3. Unplug the connection terminals and lift them clear of the Terminal Module.
4. Unplug the connector for the XCD sensor.
5. Loosen and remove the three “cross-headed” screws that secure the Terminal Module to the Transmitter housing.
6. Carefully lift the Terminal Module from the transmitter housing.
7. Fit the new Terminal Module using the above procedure in reverse order.



12.3 Faults and Warnings

The table below provides details of possible error.

Message	Description	Action
W-01	Calibration needed	The unit has not been calibrated for the configured calibration interval Calibration is necessary due to change of sensor/gas type
W-02	Transmitter Temperature limits exceeded	Use '✓' to clear when within limits
W-03	Alarm setting needs to be configured	Re-configure alarm settings such that upper alarm should not exceed user configured scale
W-04*	Over-range warning	Use '✓' to clear when within limits
W-05*	The sensor is switched off to prevent it from being deteriorated	Make sure that there is no flammable gas in the air and use '✓' to clear when within limits
F-01	Internal I2C failure	Cycle power to detector. Replace detector
F-02	Cell failure	For Flammable/IR, cycle power to detector. Replace sensor
F-03	Significant zero drift	Re zero/calibrate
F-04	Unexpected sensor fitted	Replace sensor
F-05	EEPROM is corrupted	Reset transmitter. If fault still appear, replace transmitter
F-06	Low supply voltage	Reset transmitter. If fault still appear, replace transmitter
F-07	SRS processor failure	Reset transmitter. If fault still appear, replace transmitter
F-08	RAM read/write fault	Reset transmitter. If fault still appear, replace transmitter
F-09	Info. memory corrupted	Reset transmitter. If fault still appear, replace transmitter
F-10	Code Memory corrupted	Reset transmitter. If fault still appear, replace transmitter
F-11	DAC output failure	Check load resistor or sink/source mode switch was configured properly
F-12	Heater failure	Reset transmitter. If fault still appear, replace transmitter
F-13	Supplied voltage failure	Check supply voltage. Replace detector

*Note : W-04 and W-05 are only for flammable catalytic bead sensors. For other gases, gas reading will blink on the LCD instead of the over-range warning.

Table 9: Fault and Warning List

13 Menu's and Advanced Configuration

13.1 Abort Function

In Review Mode or Configuration Mode the user can escape one step back from the current position using the Abort Function. To do this the user must activate the Enter switch for more than 3 seconds with the Magnetic Wand. Switching between each pair of modes or between menus and sub menus are shown in the following table.

From	To	Example
Review Mode	Monitoring Mode	Activate Enter switch for more than 3 seconds while in Review Mode
Configuration Mode	Monitoring Mode	Activate Enter switch for more than 3 seconds while navigating menus in the Configuration Mode
Configuration Mode sub menu	Configuration Mode main menu	Activate Enter switch for more than 3 seconds while in a sub menu

Table 10: Transmitter menu switching

13.2 Configuration Mode

The table below shows the functions available via the configuration menu that can be displayed on the transmitter and accessed using the Magnetic Wand.












The instrument will show the main Menu when the “Enter” switch is activated with the Magnetic Wand and held for at least 3 seconds.

The Menu is password protected to prevent any unauthorized changes. The password is initially disabled and the default password is ‘0000’. If the default password is changed to other than ‘0000’, then the password is enabled automatically and requested when entering Configuration Mode.

With the Menu showing, the following functions can be performed: calibration, bump test, sensor selection and configuration of parameters such as measuring range, calibration gas level, calibration interval, inhibit current, inhibit timeout, alarm setting, relay setting, password change, location setting, temperature unit reading, force analogue output and alarm function checks.

While in Configuration mode, the output current of the transmitter is inhibited to prevent false alarms.

Names, displays and descriptions for each menu item in Configuration Mode are shown in the following table.

Menu	Display	Description
Set Calibration		Execute zero/span calibration Set calibration gas level After zero, the option exists to proceed with span calibration, or return to the Menu.
Select Sensor		Select the type of sensor from the sensor list. This menu is only available for flammable / IR sensor.
Select Gas		Select the type of gas from the list. This menu is only available for flammable / IR sensor.
Set Range		Set measuring range
Configure Inhibit		Select inhibit current Set timeout option (5 minute increments)
Set Password		Enable/disable password Set password Default – no password (Select '0000')
Set Calibration Interval		Set calibration interval, 30 to 365 days User configurable option to display warning
Bump Test		Execute a 'bump' test to check gas response of the sensor.
Force Current		Force analogue output to test functionality of GD control system during system commissioning.
Set Alarms		Set alarm 1, alarm 2 levels, functionality and operation (none/falling/rising)
Set Relays		Set relay 1,2,3 type (alarm 1, alarm 2, fault and inhibit) and action (energized/de-energized)





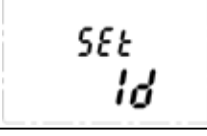
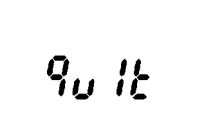
Relay Operation		Configure relay on delay time, relay off delay time and latch/non-latch
Set Location		Set location (or TAG number)
Set Temperature Unit		Change temperature display unit. °C (Celsius) or °F (Fahrenheit)
Check Alarm functions		Simulate alarm situation to check the alarm system without gas present at the sensor
Set ID		Change Modbus® slave ID, baud and parity bit setting (Modbus® version only)
Quit		Return to Monitoring mode

Table 11: Transmitter menu descriptions

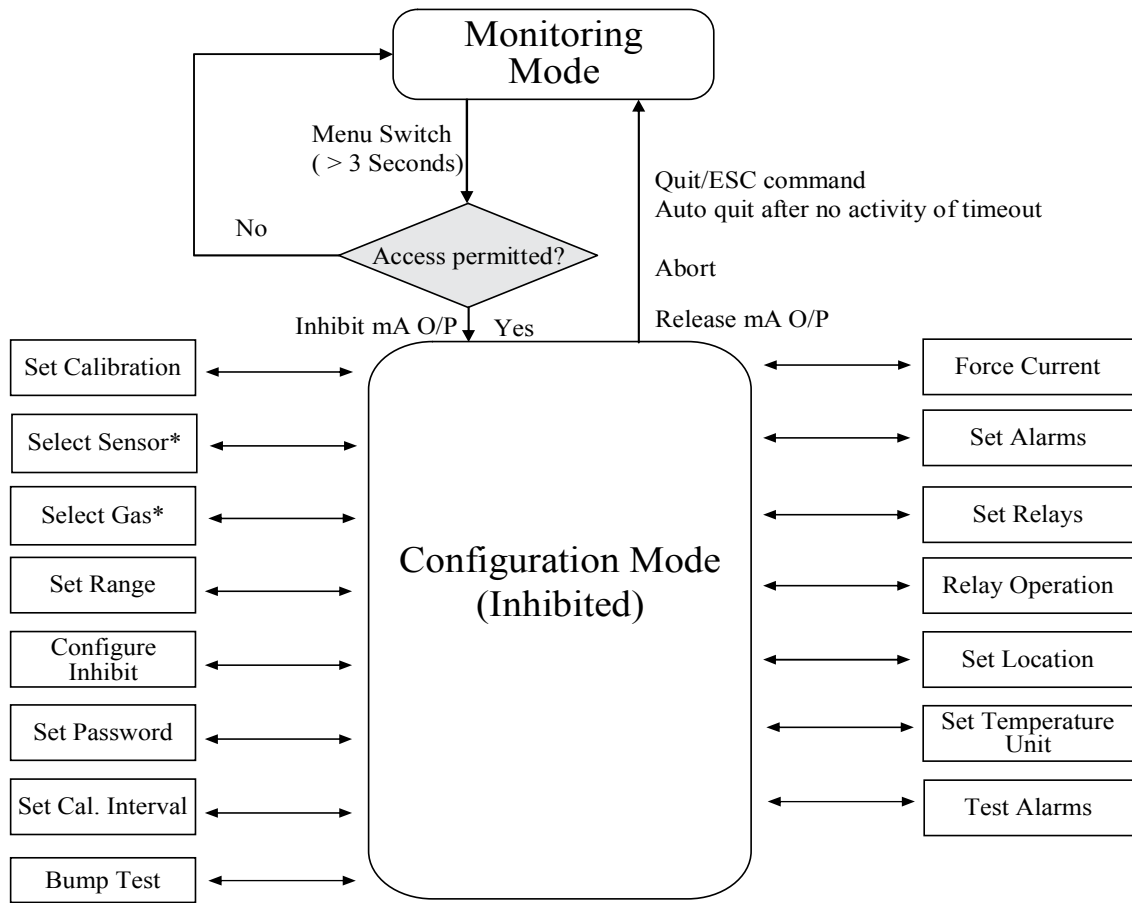


Diagram 14: Configuration Mode

13.2.1 Configuration mode operation table

Configuration mode allows the user to perform calibration and configure parameters such as full scale range, calibration gas level, calibration interval, inhibit current & timeout, alarm settings, relay settings, set a password, etc. To activate Configuration mode hold the magnet over the ENTER switch for at least 3 seconds and then remove. Configuration mode can be password protected to prevent unauthorized personnel from changing parameters. Initially the password is set to '0000' meaning it is disabled. While in Configuration mode, the output current of the detector is inhibited to prevent false alarms. Use the table below to help navigate the menus and make configuration changes. The menus are shown in the left hand column. Use ▲▼ to select the required menu and '✓' to enter. Follow the information and instructions in the table from left to right from the required menu.

▲▼	OK	▲▼	OK	▲▼	OK	▲▼	OK	▲▼
SEt CAL ¹	✓	GAS NAME, ZERO CONCENTRATION AND FLASHING '0' ICON DISPLAYED. APPLY ZERO GAS AND USE '✓' WHEN READING IS STABLE. 'ZEro PASS' DISPLAYED IF OK, 'ZEro FAIL' IF NOT.	⇒	'SPAN' DISPLAYED AND 'YES' FLASHING TO ASK IF YOU NOW WANT TO PERFORM SPAN CALIBRATION. USE '✓' TO PROCEED OR USE ▲▼ TO SELECT 'No' AND RETURN TO MENU MODE.	✓	'GAS' TARGET CONCENTRATION FLASHING AND '0' ICON DISPLAYED. USE ▲▼ TO CHANGE GAS CONCENTRATION AND '✓' TO START SPAN CALIBRATION.	✓	GAS NAME, CURRENT CONCENTRATION AND FLASHING '0' ICON DISPLAYED. APPLY SPAN GAS AND USE '✓' WHEN READING STABLE. IF OK 'PASS' & 'PurG' DISPLAYED (IF FAIL 'SPAN FAIL' DISPLAYED AND RETURNS TO MENU). REMOVE SPAN GAS. WHEN READING <50% OF SPAN POINT, COUNTDOWN BEGINS & UNIT RETURNS TO MENU MODE.
SEt rAn9	✓	BAR GRAPH INDICATING CURRENT RANGE. 'rAn9' DISPLAYED & CURRENT RANGE FLASHES. USE ▲▼ TO SELECT DIFFERENT RANGE	✓	IF RANGE IS CHANGED, 'CAL' DISPLAYED AND 'YES' FLASHING TO ASK IF YOU NOW WANT TO PERFORM CALIBRATION. USE '✓' TO PROCEED OR USE ▲▼ TO SELECT 'No'.	✓	IF RANGE IS CHANGED, 'ALrm' DISPLAYED AND 'YES' FLASHING TO ASK IF YOU NOW WANT TO MODIFY ALARM SETTINGS. USE '✓' TO PROCEED OR USE ▲▼ TO SELECT 'No' AND RETURN TO MENU MODE.	✓	UNIT RETURNS TO MENU MODE
ConF Inhb	✓	'Inhb' DISPLAYED WITH '0' ICON FLASHING. CURRENT INHIBIT mA VALUE FLASHES. USE ▲▼ TO SELECT NEW VALUE	✓	'tIme' DISPLAYED WITH '0' ICON. FLASHING CURRENT INHIBIT TIMEOUT PERIOD (MINUTES) FLASHES. USE ▲▼ TO SET NEW TIMEOUT. (IF SET TO 0 OUTPUT IS PERMANENTLY INHIBITED)	✓	UNIT RETURNS TO MENU MODE		
SEt PASS	✓	'PASS' DISPLAYED WITH FIRST DIGIT PLACE ICON OF THE PASSCODE FLASHING. USE ▲ TO SELECT 1 ST DIGIT OF CURRENT PASSWORD. USE ▼ TO MOVE TO NEXT DIGIT AND SET REST OF PASSCODE.	✓	UNIT RETURNS TO MENU MODE				
CAL Int3 ²	✓	'Int' DISPLAYED WITH CURRENT CALIBRATION INTERVAL FLASHING. USE ▲▼ TO CHANGE INTERVAL.	✓	'duE' DISPLAYED AND 'No', 'LCd' OR 'ALL' FLASHING. USE ▲▼ TO SELECT REQUIRED CAL DUE WARNING OUTPUT.	✓	UNIT RETURNS TO MENU MODE		

bumP tEst	✓	PEAK READING DISPLAYED WITH OUTPUT INHIBITED '🚫' ICON AND PEAK STRING FLASHING. APPLY BUMP TEST GAS AND CHECK PEAK READING ON DISPLAY.	✓	CURRENT GAS CONCENTRATION DISPLAYED WITH OUTPUT INHIBITED '🚫' ICON FLASHING.	✓	UNIT RETURNS TO MENU MODE	
Forc Curr	✓	'Forc' DISPLAYED WITH '🚫' ICON. DEFAULT FORCE CURRENT '4.00' FLASHES. USE ▲▼ TO CHANGE TO REQUIRED mA LEVEL.	✓	UNIT TRANSMITS THE CURRENT IF YOU WANT TO EXIT FROM THIS MENU, USE ABORT FUNCTION			
Set ALrm	✓	'AL1', ICON DISPLAYED AND CURRENT ALARM LEVEL 1 CONCENTRATION FLASHES. USE ▲▼ TO CHANGE TO REQUIRED CONCENTRATION LEVEL.	✓	'AL1' DISPLAYED WITH 'None', 'RISE' OR 'FALL' FLASHING. USE ▲▼ TO SELECT REQUIRED ALARM ACTION.	✓	'AL2', ICON DISPLAYED AND CURRENT ALARM LEVEL 2 CONCENTRATION FLASHES. USE ▲▼ TO CHANGE TO REQUIRED CONCENTRATION LEVEL.	'AL2' DISPLAYED WITH 'None', 'RISE' OR 'FALL' FLASHING. USE ▲▼ TO SELECT REQUIRED ALARM ACTION AND USE '✓' TO RETURN TO MENU MODE.
Set rLY	✓	'rL1' DISPLAYED AND 'AL1', 'AL2', 'Inht' or 'FLt' FLASHES. USE ▲▼ TO CHANGE TO REQUIRED RELAY TARGET.	✓	'rL1' DISPLAYED AND 'dEEn' or 'Enr9' FLASHES. USE ▲▼ TO CHANGE TO REQUIRED RELAY ACTION.	✓	'RI2' DISPLAYED AND 'AL1', 'AL2', 'Inht' or 'FLt' FLASHES. USE ▲▼ TO CHANGE TO REQUIRED RELAY TARGET.	'rL2' DISPLAYED AND 'dEEn' or 'Enr9' FLASHES. USE ▲▼ TO CHANGE TO REQUIRED RELAY ACTION.
	✓	'rL3' DISPLAYED AND 'AL1', 'AL2', 'Inht' or 'FLt' FLASHES. USE ▲▼ TO CHANGE TO REQUIRED RELAY TARGET.	✓	'rL3' DISPLAYED AND 'dEEn' or 'Enr9' FLASHES. USE ▲▼ TO CHANGE TO REQUIRED RELAY ACTION.	✓	UNIT RETURNS TO MENU MODE	
rLY OPr	✓	'rLY', 'ON' DISPLAYED AND CURRENT RELAY-ON TIME FLASHES. USE ▲▼ TO CHANGE TO REQUIRED RELAY-ON DELAY.	✓	'rLY', 'OFF' DISPLAYED AND CURRENT RELAY-OFF TIME FLASHES. USE ▲▼ TO CHANGE TO REQUIRED RELAY-OFF DELAY.	✓	'Ltch' DISPLAYED AND 'YES' or 'No' FLASHES. USE ▲▼ TO CHANGE TO REQUIRED LATCH OPTION.	UNIT RETURNS TO MENU MODE
Set Loc	✓	'Loc' DISPLAYED WITH FIRST 4 CHARACTERS OF THE LOCATION STRING. USE ▼ TO CHANGE THE 1ST CHARACTER OF CURRENT LOCATION STRING. USE ▲ TO MOVE TO NEXT CHARACTER AND SET REST OF STRING. MAXIMUM 12 CHARACTERS CAN BE SET.	✓	'Loc' DISPLAYED NEW LOCATION STRING. THE STRING MOVES RIGHT-TO-LEFT TO SHOW WHOLE CHARACTERS TWICE. THEN UNIT AUTOMATICALLY RETURNS TO MENU MODE.			
tEm PUnT	✓	'tEmP' DISPLAYED WITH '°C' OR '°F' FLASHING. USE ▲▼ TO CHANGE TO REQUIRED TEMPERATURE UNIT.	✓	UNIT RETURNS TO MENU MODE			
tES tALrm	✓	'Forc' DISPLAYED and 'AL1' FLASHING TO SELECT TEST-REQUIRED ALARM. USE '✓' TO FORCE ALARM1.	✓	GAS NAME, CURRENT GAS CONCENTRATION DISPLAYED AND '🚫' 'AL' ICON FLASHES.	✓	UNIT RETURNS TO MENU MODE	
9ult	✓	QUITS MENU MODE AND RETURNS TO MONITORING MODE					
▲▼	OK	▲▼	OK	▲▼	OK	▲▼	OK

¹ Refer to section 10.1 for detailed zero and span calibration procedures. Re-calibrate the detector if left un-powered for periods in excess of 24 hours.

² The calibration due warning counter is automatically reset after a successful calibration.

Table 12. Configuration Mode Operation

13.3 Sensor / Gas Selection

13.3.1 Sensor Selection

“Select Sensor” sets the identity of the type of mV sensor attached to the XCD RFD when it does not detect the sensor type automatically.

The available mV sensors:

Cb-2	Sensepoint HT 20%LEL remote
Cb-3	Sensepoint HT 100%LEL remote
Cb-4	Sensepoint 100%LEL remote
Cb-5*	Flammable CAT 0-100%LEL remote
Cb-6	705 100%LEL remote (CSA Certified)
Cb-7	705 HT 100%LEL remote
Ir-5*	Carbon Dioxide IR 0-2%VOL only remote
Ir-7	Methane IR 0-100%LEL remote
Ir-8*	Propane IR 0-100%LEL remote

Selecting ‘✓’ will move the operator to the Select Sensor screen. The first screen displays the currently configured sensor. To select a new mV sensor like remote type sensors (Ir-7, Cb-3 and Cb-4), use ‘▲▼’ to move through the list, and then use ‘✓’ to make the selection or discard the selection and return to menu mode by using abort function. If type of sensor is changed, calibration prompt will appear to ask if you want to perform calibration.

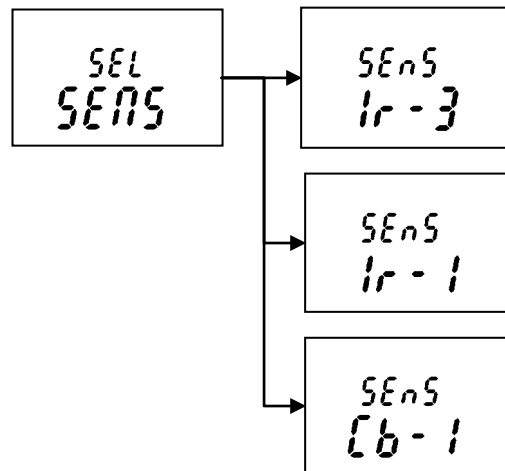


Diagram 15: Sensor Selection

13.3.2 Gas Selection

Use “SEL gAS” to set the target gas for sensors capable of detecting multiple gases. The available gases:

Sensor type	Gas type	Gas Name displayed
Cb-3	Str 1 to Str 8	FLM
Cb-4	Str 1 to Str 8	FLM
Cb-5*	Str 1 to Str 8	FLM
Cb-6	Str 1 to Str 8	FLM
Cb-7	Str 1 to Str 8	FLM

Ir-5*	CO2	CO2
Ir-7	Methane	mEt
Ir-8*	Propane	ProP

*Contact Honeywell Analytics for availability

Gas selection is dependent on the type of sensor attached to the XCD RFD. If Ir-7 sensor is attached, then a user can only select 'mEt' gas respectively. But when Cb-3/Cb-4 sensor is attached to the XCD RFD, a user can select the gas from Str1 (1*) to Str8 (8*). For more information on star rating, please refer to section 19.2.

The current configuration of the XCD RFD is displayed and by using the '✓' switch to enter "SEL gAS" menu. To select a flammable gas, use '▲▼' to move through the list, and then use '✓' to make the selection or abort function to discard the selection and return to menu mode.

If type of gas is changed, calibration prompt will appear to ask if you want to perform calibration.

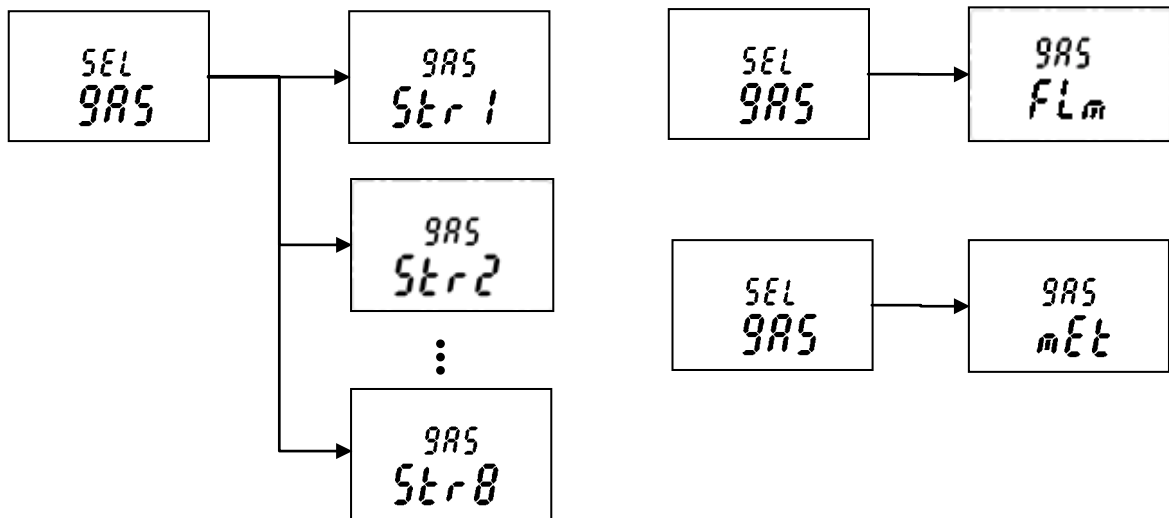


Diagram 16: Gas Selection

CAUTION

The 4-20mA analogue output signal will remain INHIBITED at 2mA (default setting) while the XCD RFD remains in Configuration Mode. However, the ALARM and FAULT RELAYS remain Active.

Changing the configuration of the Sensor Type or the Gas Star Rating for catalytic sensors may result in temporary activation of the ALARM or FAULT RELAYS. Should this occur, then recalibrating the sensor will return the XCD RFD to normal condition and reset the relays.

As a precaution, please take necessary action to manually inhibit any external actuator or alarm devices that are connected to the XCD RFD Alarm/Fault Relays to prevent unnecessary activation during commissioning or reconfiguration of the XCD RFD gas detector. For CSA Certified applications, use CB-6 calibrated only to Methane.

13.4 Review Mode

The instrument will enter **Review mode** when the “Enter” switch is activated with the Magnetic Wand and held for around one second.

Names, displays and descriptions for each review item in Review Mode are shown in the following table.

Item name	Display	Description
Software version		S/W version of transmitter
SRS version		S/W version of SRS (watch dog)
EEP version		EEPROM parameter version
Gas		Gas type
Measuring range		A user selected measuring range
Calibration level		Calibration gas level
Calibration due		Estimated time to next calibration
Alarm 1		Alarm settings for Alarm 1
Alarm 2		Alarm settings for Alarm 2






Location		Location in which the transmitter is installed
Power		Power voltage*
Temperature		Internal Transmitter temperature*
Peak conc.		Maximum concentration detected up to now
Test Result		There is no fault detected.

Table 13: Transmitter menu descriptions

Note:

**Power voltage and internal transmitter temperature may be different from actual value due to measuring accuracy and internal heating components.*

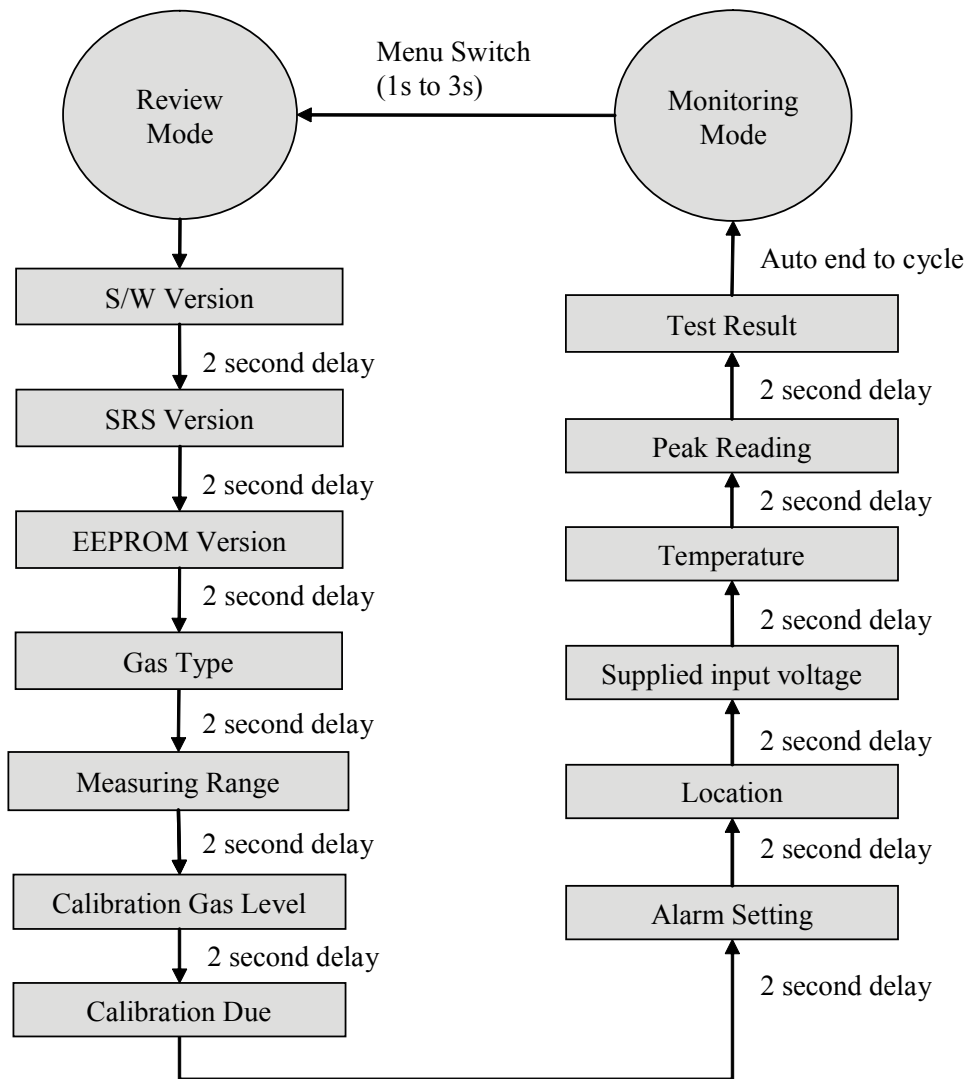


Diagram 17: Review Mode

14 General specification

Sensepoint XCD Transmitter												
Use	3-wire, 4-20mA, gas detector transmitter for use with remotely mounted flammable gas detectors.											
Electrical												
	Input Voltage Range:	12 to 32Vdc (24Vdc nominal)										
	Max Power Consumption:	Max 5 Watts. at 24Vdc (see section 2 regarding maximum in rush current)										
	Current output	4-20mA (Source or Sink)										
	≥0.0<1.0 mA	Fault (refer to table 5 section 12.3 for further details)										
	4.0 mA to 20.0 mA	Normal gas measurement										
	2.0 mA or 4.0 mA	Inhibit (during configuration/user settings)										
	22.0 mA	Maximum over range										
	Terminals	15 x screw terminals suitable for wire diameter 0.5mm ² to 2.5mm ² (20AWG to 13AWG).										
	Relays	3 x 5A@250VAC. Selectable normally open or normally closed (switch) and energized/de-energized (programmable).										
	Communication	RS485, Modbus RTU										
Construction												
Material	Epoxy painted aluminium alloy or 316 Stainless Steel											
Weight	Aluminium alloy: 1.7kg, 316 Stainless Steel: 3.7kg											
Mounting	Pole or wall mounting											
Cable Entries	2 x M20 (for ATEX/IECEX/AP Approval) , or 2 x 3/4"NPT (for cCSAus Approval)											
Sensor Entry	M25 (for ATEX/IECEX/AP Approval) or 3/4"NPT (for cCSAus Approval)											
Detectable Gases & Performance (See notes below)												
Gas	Selectable Full Scale Range	Default Range	Steps	Selectable Cal Gas Range	Default Cal Point	Response Time (T60) Secs	Response Time (T90) Secs	Accuracy	Operating Temperature		Default Alarm Points	
									Min	Max	A1	A2
Sensepoint Standard Temperature Sensor												
Flammable 1 to 8*	20 to 100%LEL	100%LEL	10%LEL	25 to 95% of selected full scale range	50%LEL	<25	<25	<+/- 1.5%LEL	-55°C / -67°F	80°C / 176°F	20%LEL▲	40%LEL▲
Sensepoint High Temperature Sensor												
Flammable 1 to 8*	20%LEL	20%LEL	n/a	30 to 70% of selected full scale range	10%LEL	<25	<25	<+/- 1.5%LEL	-55°C / -67°F	150°C / 302°F	10%LEL▲	15%LEL▲
Flammable 1 to 8*	20 to 100%LEL	100%LEL	10%LEL		50%LEL	<10	<10	<+/- 1.5%LEL	-55°C / -67°F	150°C / 302°F	20%LEL▲	40%LEL▲
Plug-in Sensepoint XCD Catalytic Bead Sensors												
Flammable 1 to 8*	20 to 100%LEL	100%LEL	10%LEL		50%LEL	<6	<25	<+/- 1.5%LEL	-20°C / -4°F	55°C / 131°F	20%LEL▲	40%LEL▲
Plug-in Sensepoint XCD Infrared Sensors												
Methane	20 to 100%LEL	100%LEL	10%LEL		50%LEL	<40	<40	<+/- 1.5%LEL	-20°C / -4°F	50°C / 122°F	20%LEL▲	40%LEL▲
Propane*	20 to 100%LEL	100%LEL	10%LEL		50%LEL	<40	<40	<+/- 1.5%LEL	-20°C / -4°F	50°C / 122°F	20%LEL▲	40%LEL▲
Carbon Dioxide*	2.00%Vol	2.00%Vol.	n/a		1.00%Vol.	<40	<40	<+/-0.04%Vol.	-20°C / -4°F	50°C / 122°F	0.40%V/V.▲	0.80%V/V.▲
*Contact Honeywell Analytics for availability												
▲ - Rising Alarm ▼ - Falling Alarm												
NOTES												
Performance figures are taken at 20-25°C:												
1. measured using a sample humidity of 50%RH, applicable between 10 and 90% of full scale,												
2. measured using test units calibrated at 50% of full scale,												
3. measured at 1000cc/min for Methane CAT, 500cc/min for Methane IR with calibration cup (S3KCAL).												
Response time (T90) may increase when operating in lower or higher temperature conditions or when gas is introduced with the Weather Protection accessory (SPXCDWP) fitted. Methane IR sensor is calibrated and linearised only for Methane. Should it be exposed to other HC then non linear response is expected. For linearised operation other than Methane contact HA for alternate parts.												
Methane IR is calibrated at the factory 50%LEL Methane (2.5%Vol). This calibration enables 100% functional test prior to dispatch. This calibration does not remove need for calibration & test as part of commissioning at site. For gases other than Methane the unit has to be calibrated at site using target gas.Data represents typical values, and system conditioning may be required to achieve stated result.												
Contact HA for details.												
* Extended operating temperature range of -40°C to +65°C (-40°F to +149°F) for all sensor except for IR, with an accuracy of +/- 30% of applied gas from -20°C to -40°C (-4°F to -40°F) and +55°C to +65°C (+131°F to +149°F). Long term operation at this range may cause decline in sensor performance.												
Contact Honeywell Analytics for any additional data or details.												
Certification												
China	GB Ex d IIC T4 GB3836.1&2 -2000, PA, CCCF											
Korea	KTL Ex d IIC T6 (-40°C to +65°C)											
European	ATEX Ex II 2 GD Ex d IIC Gb T6(Ta -40°C to +65°C) Ex tb IIIC T85°C Db IP66											
International	IEC Ex II 2 GD Ex d IIC Gb T6(Ta -40°C to +65°C) Ex tb IIIC T85°C Db IP66											
North America	cCSAus Class I, Division 1, Groups B, C & D/ Flammable Performance CSA C22.2 No.152 and ISA 60079-29-1(Only combustion gas detection portion of the instrument has been assessed)											
CE	EN50270:2015 EN6100-6-4:2007											
Environmental												
IP Rating	IP66 in accordance with EN60529:1992, NEMA 4X (Tested by third party laboratory)											
Operating Temperature	-40°C to +65°C/ -40°F to +149°F, (IR: -20°C to +50°C/ -4°F to +122°F) <i>Note: The detector display may become illegible at temperatures below -20°C, but the detector continues its gas monitoring function. The display is not damaged and recovers when the temperature rises back above -20 °C.</i>											
Operating Humidity	Continuous 20-90%RH (non condensing), Intermittent 10-99%RH (non condensing)											
Operating Pressure	90-110kPa											
Storage Conditions	-25°C to +65°C (-13°F to +149°F)											

15 Ordering information

Part number	Description
Sensepoint XCD RFD transmitter (LM25)	
SPXCDALMRFD	ATEX/IECEX/AP* approved SP XCD RFD Transmitter with LM25, M20 Entry, without MODBUS
SPXCDULNRFD	cCSAus approved SP XCD RFD Transmitter with LM25, 3/4"NPT Entry, without MODBUS
SPXCDALMRFDM	ATEX/IECEX/AP* approved SP XCD RFD Transmitter with LM25, M20 Entry, with MODBUS
SPXCDULNRFDM	cCSAus approved SP XCD RFD Transmitter with LM25, 3/4"NPT Entry, with MODBUS
Sensepoint XCD RFD transmitter (316SS)	
SPXCDASMRFD	ATEX/IECEX/AP* approved SP XCD RFD Transmitter with 316SS
SPXCDUSNRFD	cCSAus approved SP XCD RFD Transmitter with 316SS, 3/4"NPT Entry, without MODBUS
SPXCDASMRFDM	ATEX/IECEX/AP* approved SP XCD RFD Transmitter with 316SS, M20 Entry, with MODBUS
SPXCDUSNRFDM	cCSAus approved SP XCD RFD Transmitter with 316SS, 3/4"NPT Entry, with MODBUS
Replacement Sensepoint XCD sensor cartridge	
SPXCDXSFSS**	Flammable CAT 0-100%LEL (20,0 to 100.0%LEL)
SPXCDXSRSS	Methane IR 0-100%LEL (20,0 to 100.0%LEL)
SPXCDXSPSS**	Propane IR 0-100%LEL (20,0 to 100.0%LEL)
SPXCDXSB1SS**	Carbon Dioxide IR 0-2.00%VOL only
Remote Flammable Sensor (XCD Sensor Cartridge + Socket Housing)	
SPXCDXSRFXSS**	Flammable CAT 0-100%LEL (20,0 to 100.0%LEL)
SPXCDXSRXSS	Methane IR 0-100%LEL (20,0 to 100.0%LEL)
SPXCDXSRPXSS**	Propane IR 0-100%LEL (20,0 to 100.0%LEL)
SPXCDXSRBXSS**	Carbon Dioxide IR 0-2.00%VOL only
Replacement Sensepoint Sensor	
2106B1200	Standard LEL Version , -55°C to +80°C, M20 version, ATEX Certification
2106B1201	Standard LEL Version, -55°C to +80°C, M25 version, ATEX Certification
2106B1204	Standard LEL Version , -55°C to +80°C, 3/4 NPT version, ATEX Certification
00705-A-1733	Standard LEL Version, -55°C to +80°C, Aluminium, 3/4NPT Version, UL Certification
2106B2310	High temperature LEL Version, -40°C to +150°C, M20 version, ATEX Certification
2106B2311	High temperature LEL Version, -40°C to +150°C, M25 version, ATEX Certification
2106B2312	High temperature LEL Version, -40°C to +150°C, 3/4 NPT version, ATEX Certification
00705-A-1735	Standard LEL Version, -40°C to +150°C, Aluminium, 3/4NPT Version, UL Certification
Sensepoint XCD Accessories	
S3KCAL	Calibration cap
SPXCDWP	Weather Protection
SPXCDCC	Collecting cone for use with lighter than air gases
SPXCDDMK	Duct mounting kit
SPXCDMTBR	Pipe Mounting bracket (inc. fixings and hex wrench set)
SPXCSDP	Sunshade / Deluge Protection
SPXCDHMRFEEN	Hard Copy Manual in English
Sensepoint / 705 Accessories	
2430-0021	UL/CSA Aluminum 3 wire Junction Box Assembly
00780-A-0100	ATEX/IECEX Junction Box (3) M20, (1) M25 entries.
2052D0001	ATEX High Temperature Junction Box.
02000-A-1642	Collecting Cone
02000-A-1645	Calibration Gas Flow Housing for Sensepoint Sensors
00780-A-0035	Calibration Gas Flow Housing for 705 Sensors
00780-A-0076	Weather Protection Stainless Steel for high temps.

02000-A-1640	Nylon Weather Protection Housing for Sensepoint Combustible Sensors
02000-A-1635	Weather Protection Housing for 705 Sensors
1283-1047	Duct Mount Adaptor Assembly
Sensepoint XCD Spares	
SPXCDDMR	Replacement display module for RFD (4~20mA), without MODBUS
SPXCDTMR	Replacement terminal module for RFD (4~20mA)
SPXCDDMRM	Replacement display module for RFD (4~20mA), with MODBUS
SPXCDNPTP	3/4" NPT Plug
SPXCDM20P	M20 Plug
SPXCDMANCDRFD	Instruction manual CD
SPXCDMAG	Magnet
SPXCDSRLS	Sensor Retainer with locking screw
SPXCDAKS	Allen key for stopper
SPXCDHWES	Hex wrench for earth screw
SPXCDEBS	Earth Bracket and Screws
Sensepoint Spares	
00780-F-0018	Stainless steel filter, High temperature LEL Version, -40°C to +150°C
00780-C-0038	Filter Housing, High temperature LEL Version, -40°C to +150°C

* AP approvals include GB & PA for China and KTL for Korea.

**Contact Honeywell Analytics for availability.

16 Warranty statement

All products are designed and manufactured to the latest internationally recognized standards by Honeywell Analytics under a Quality Management system that is certified to ISO 9001. As such Honeywell Analytics warrants its products against defective parts and workmanship and will repair or (at its option) replace any instruments which are or may become defective under proper use within 12 months from date of commissioning by an approved Honeywell Analytics representative or 18 months from date of shipment from Honeywell Analytics, whichever is the sooner. This warranty does not cover disposable batteries or damage caused by accident, abuse, abnormal operating conditions or poisoning of sensor.

Defective goods must be returned to Honeywell Analytics premises accompanied by a detailed description of any issue. Where return of goods is not practicable Honeywell Analytics reserves the right to charge for any site attendance where any fault is not found with the equipment. Honeywell Analytics shall not be liable for any loss or damage whatsoever or howsoever occasioned which may be a direct or indirect result of the use or operation of the Contract Goods by the Buyer or any Party.

This warranty covers instrument and parts sold to the Buyer only by authorized distributors, dealers and representatives as appointed by Honeywell Analytics. The warranties set out in this clause are not pro rata, i.e. the initial warranty period is not extended by virtue of any works carried out there under.


In no event will Honeywell Analytics be liable for any incidental damages, consequential damages, special damages, punitive damages, statutory damages, indirect damages, loss of profits, loss of revenues, or loss of use, even if informed of the possibility of such damages. Honeywell Analytics's liability for any claims arising out of or related to this product will in no case exceed the order value. To the extent permitted by applicable law, these limitations and exclusions will apply regardless of whether liability arises from breach of contract, warranty, tort (including but not limited to negligence), by operation of law, or otherwise.

17 Installation Drawing

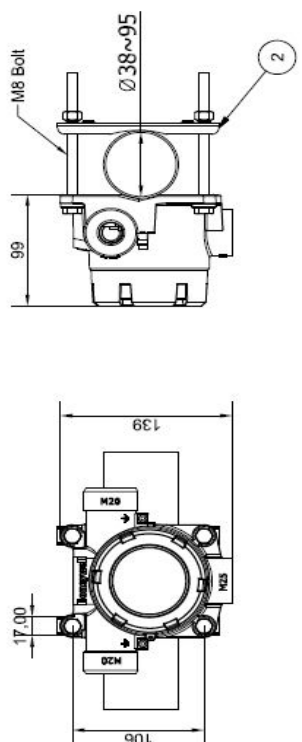
17.1 Mechanical Installation Drawing

3001G0453 SHT. 1

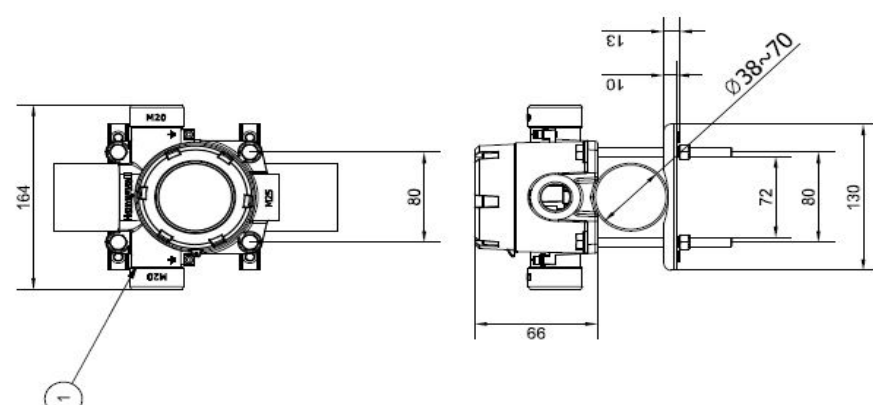
THIS DOCUMENT HAS BEEN GENERATED USING AutoCAD AND MUST ONLY BE UPDATED BY C.A.D.



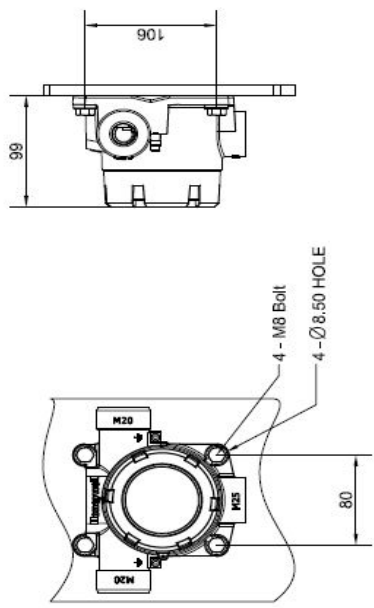
Horizontal Pipe Mounted



Vertical Pipe Mounted



Wall Mounted



I. SPECIFICATION

- SIZE: 164 X 217 X 99
- MATERIAL
 - TRANSMITTER: LM25 / 316SS
 - MOUNTING BRACKET: 316SS
- WEIGHT: 2kg / 4.5kg
 - TRANSMITTER(LM25): 1.8kg
 - TRANSMITTER(316SS): 4.3kg
 - MOUNING BRACKET: 0.2kg

II. HAZARDOUS CERTIFICATION

- ATEX
 - GD
 - Ex d IIC Gb T6(Ta -40 °C to +65 °C)
 - Ex tb IIC T85 °C Db IP66
 - Baseefa08ATEX0222
 - KTLL
 - Ex d IIC T6, 12~32Volts DC, Pmax=5W
 - Tamb, -40 °C to +65 °C
 - GB, PA

III. ITEM LIST

- XCD RFD TRANSMITTER
- PIPE MOUNTING BRACKET

THIS ITEM FORMS PART OF A CERTIFIED PRODUCT
NO MODIFICATION PERMITTED WITHOUT
REFERENCE TO CERTIFICATION DEPARTMENT

MATERIAL		SCALE		DRN		SA		TITLE	
		NTS		A		B		C	
		DATE		DATE		DATE		DATE	
F	28JUN16	07/JUN/10	04/MAY/10	07/APR/10	03/MAR/10	07/DEC/09			
	Changed Voltage Sheet	Add Sheet	Table Change Sheet	Text Modify	New Drawing				
	Jeffrey Lee	J.Y.JIN	J.Y.JIN	J.Y.JIN	J.Y.JIN	J.Y.JIN	J.Y.JIN	J.Y.JIN	J.Y.JIN

FINISH: ALL DIMENSIONS IN MILLIMETRES UNLESS OTHERWISE STATED. AND APPLY AFTER PLATING.

THIS DRAWING IS TO BS 8888

REMOVE ALL BURRS AND SHARP EDGES

SURFACE TEXTURE VALUES ARE IN μm Ra AND TO BS 1134

TOLERANCES TO BE AS SPECIFIED, BELOW UNLESS OTHERWISE STATED.	
Holes:	+ 0.08
	- 0.0
	+ 0.1
	- 0.0
	+ 0.12
	- 0.0

APPROVED: _____

DATE: _____

SCALE: _____

PROJECT: _____

REV: _____

DATE: _____

BY: _____

CHECKED: _____

DATE: _____

BY: _____

DATE: _____

3001G0453

Sensepoint XCD RFD Installation Drawing

SHT. 1 OF 5

AS

17.2 Electronic Connection Drawing

3001G0453

SHT. 2

Honeywell

THIS DOCUMENT HAS BEEN GENERATED USING AutoCAD AND MUST ONLY BE UPDATED BY C.A.D.

Controller & Transmitter

3 Wire 4~20mA (Source) with Relays

3 Wire 4~20mA (Sink) with Relays

Terminal Module Connections			Description
Terminal Number	Marking	Connection	
1	24V	+VE Supply(12-32VDC)	Controller Connections
2	0V	-VE Supply(0VDC)	
3	4~20mA	Current Output Signal	
4	COM	Common	MODBUS RTU, RS485(Pending)
5	TXD	MODBUS B (+)	
6	RXD	MODBUS A (-)	Programmable Relay 1 (Default A1)
7	RLY1/COM	Normally Closed	
8	RLY1/COM	Common	Programmable Relay 2 (Default A2)
9	RLY1/NO	Normally Open	
10	RLY2/NC	Normally Closed	Programmable Relay 3 (Default Fault)
11	RLY2/COM	Common	
12	RLY2/NO	Normally Open	RFD Sensor Connection
13	RLY3/NC	Normally Closed	
14	RLY3/COM	Common	
15	RLY3/NO	Normally Open	
16	+VE	Sensitive (Sensor Brown Wire)	
17	-VE	Non-Sensitive (Sensor Blue Wire)	
18	01	Signal (Sensor White Wire)	

NOTES:

- REFER TO INSTRUCTION MANUAL FOR TECHNICAL DETAILS.
- XCD OPERATING VOLTAGE 12~32Volts DC, 5W(Max)
- 4~20 mA LOOP RESISTANCE TO BE < 300 ohms
- POWER SUPPLY LOOP RESISTANCE TO BE < 12 ohm
- NO TWO 'EARTH POINTS' SHOULD BE CONNECTED VIA SCREEN AND/OR CONDUIT SO AS TO AVOID 'GROUND LOOPS'.
- MULTIPLE 'EARTH POINTS' ARE NOT ALLOWED.
- 'IG' POINTS' (CONTINUITY OF SCREEN) MAY BE ACHIEVED USING APPROPRIATE GLANDS/CABLE OR CONDUIT; INTERNAL AND EXTERNAL 'EARTH POINTS' IN THE TRANSMITTER ARE PROVIDED.

THIS ITEM FORMS PART OF A CERTIFIED PRODUCT NO MODIFICATION PERMITTED WITHOUT REFERENCE TO CERTIFICATION DEPARTMENT

MATERIAL		SCALE		DRN		SA	
		NTS		TITLE		2008-12-07	
F	28Jul16	07Jan10	04May10	07Apr10	03Mar10	07Dec08	
E	Changed Voltage	Add Sheet	Table Change	Add Sheet	Text Modify	New Drawing	
D	Jeffrey Lee	J.Y.JIN	J.Y.JIN	J.Y.JIN	J.Y.JIN	J.Y.JIN	
C							
B							
A							
<p style="font-size: large;">Sensepoint XCD</p> <p style="font-size: large;">RFD Installation</p> <p style="font-size: large;">Drawing</p>							<p style="font-size: large;">3001G0453</p>
							<p style="font-size: x-small;">SHT. 2 OF 5</p>

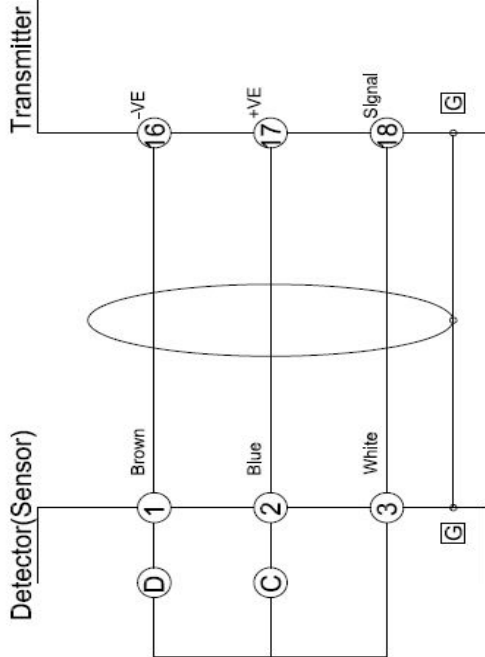


THIS DOCUMENT HAS BEEN GENERATED USING AutoCAD AND MUST ONLY BE UPDATED BY C.A.D.

3001G0453 SHT. 3

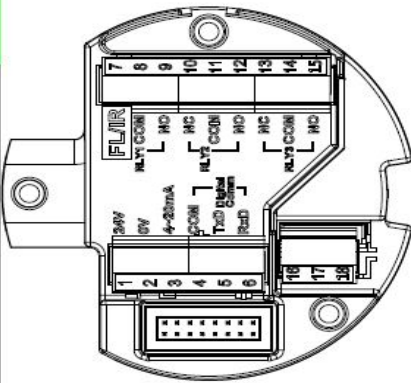
Transmitter & Detector (Sensor)

3 Wire Flammable / IR Sensor



NOTES:

- REFER TO INSTRUCTION MANUAL FOR TECHNICAL DETAILS.
- XCD OPERATING VOLTAGE 12-32Volts DC, 5W(Max)
- 4-20 mA LOOP RESISTANCE TO BE < 300 ohms
- POWER SUPPLY LOOP RESISTANCE TO BE < 12 ohm
- NO TWO 'EARTH POINTS' SHOULD BE CONNECTED VIA SCREEN AND/OR CONDUIT SO AS TO AVOID 'GROUND LOOPS'.
- MULTIPLE 'EARTH POINTS' ARE NOT ALLOWED.
- '[G] POINTS' (CONTINUITY OF SCREEN) MAY BE ACHIEVED USING APPROPRIATE GLANDS/CABLE OR CONDUIT; INTERNAL AND EXTERNAL 'EARTH POINTS' IN THE TRANSMITTER ARE PROVIDED.



Terminal Module Connections

Terminal Number	Marking	Connection	Description
1	24V	+VE Supply(12-32VDC)	Controller Connections
2	0V	-VE Supply(0VDC)	
3	4~20mA	Current Output Signal	MODBUS RTU. RS485(Pending)
4	COM	Common	
5	TxD	MODBUS B (+)	Programmable Relay 1 (Default A1)
6	RxD	MODBUS A (-)	
7	RLY1/NC	Normally Closed	Programmable Relay 2 (Default A2)
8	RLY1/COM	Common	
9	RLY1/NO	Normally Open	Programmable Relay 3 (Default Fault)
10	RLY2/NC	Normally Closed	
11	RLY2/COM	Common	RFD Sensor Connection
12	RLY2/NO	Normally Open	
13	RLY3/NC	Normally Closed	Sensitve (Sensor Brown Wire)
14	RLY3/COM	Common	
15	RLY3/NO	Normally Open	Non-Sensitve (Sensor Blue Wire)
16	+VE	Sensitve (Sensor Brown Wire)	
17	-VE	Non-Sensitve (Sensor Blue Wire)	Signal (Sensor White Wire)
18	01	Signal (Sensor White Wire)	

THIS ITEM FORMS PART OF A CERTIFIED PRODUCT NO MODIFICATION PERMITTED WITHOUT REFERENCE TO CERTIFICATION DEPARTMENT


FINISH		MATERIAL							SCALE	DRW#	SA									
ALL DIMENSIONS IN MILLIMETRES UNLESS OTHERWISE STATED. AND APPLY AFTER PLATING		<p>29/JUN/16 07/JUN/16 04/MAY/16 07/APR/16 03/MAR/16 07/DEC/09</p> <p>Changed Voltage Sheet Jeffrey J.Y.JIN</p> <p>Add Sheet J.Y.JIN</p> <p>Table Change J.Y.JIN</p> <p>Text Add J.Y.JIN</p> <p>Modfy Sheet J.Y.JIN</p> <p>New Drawing J.Y.JIN</p>							NTS	A	B	C	D	E	F	DATE	CHAR#	APP'D		
<p>TOLEANCES TO BE AS SPECIFIED BELOW UNLESS OTHERWISE STATED.</p> <p>DIMS. 2 DP ± 0.1 mm</p> <p>1 DP ± 0.25 mm</p> <p>NONE ± 0.4 mm</p> <p>ANGULAR ± 1/2°</p>		<p>HOLE. Ø 0 to 8 + 0.08</p> <p>Ø 8 to 14 + 0.1</p> <p>Ø 14 to 25 + 0.12</p> <p>- 0.0</p> <p>- 0.0</p> <p>- 0.0</p>							Issue											
<p>THIS DRAWING IS CONFIDENTIAL. IT IS THE PROPERTY OF HONEYWELL ANALYTICS LTD AND MUST NOT BE REPRODUCED EITHER WHOLLY OR PARTLY. ALL RIGHTS IN RESPECT OF PATENTS, DESIGNS AND COPYRIGHT ARE RESERVED.</p>		<p>REMOVE ALL BURRS AND SHARP EDGES</p> <p>SURFACE TEXTURE VALUES ARE IN µm Ra AND TO BS 1134</p>							3001G0453	2009-12-07										
<p>3001G0453</p> <p>Sensepoint XCD RFD Installation Drawing</p> <p>3001G0453</p>																				
											SPT.3	OF 5	A3							

17.3 Duct Mounting Drawing

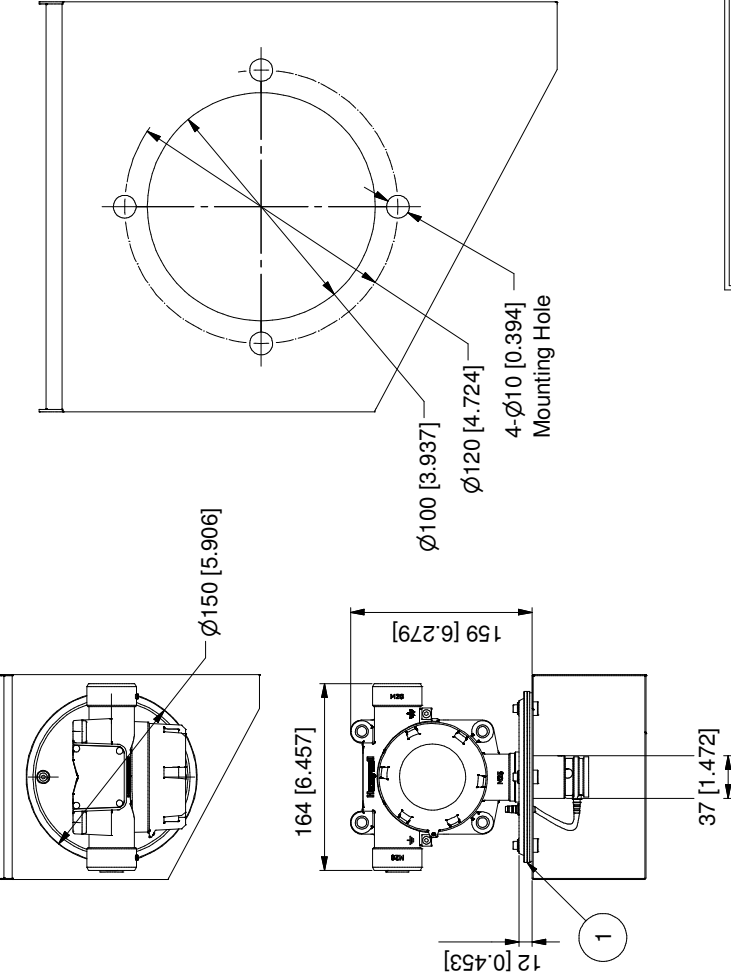
3001G0471 SHT. 3

I. ITEM LIST
1. DUCT MOUNTING PLATE

THIS DOCUMENT HAS BEEN GENERATED USING AutoCAD AND MUST ONLY BE UPDATED BY C.A.D.



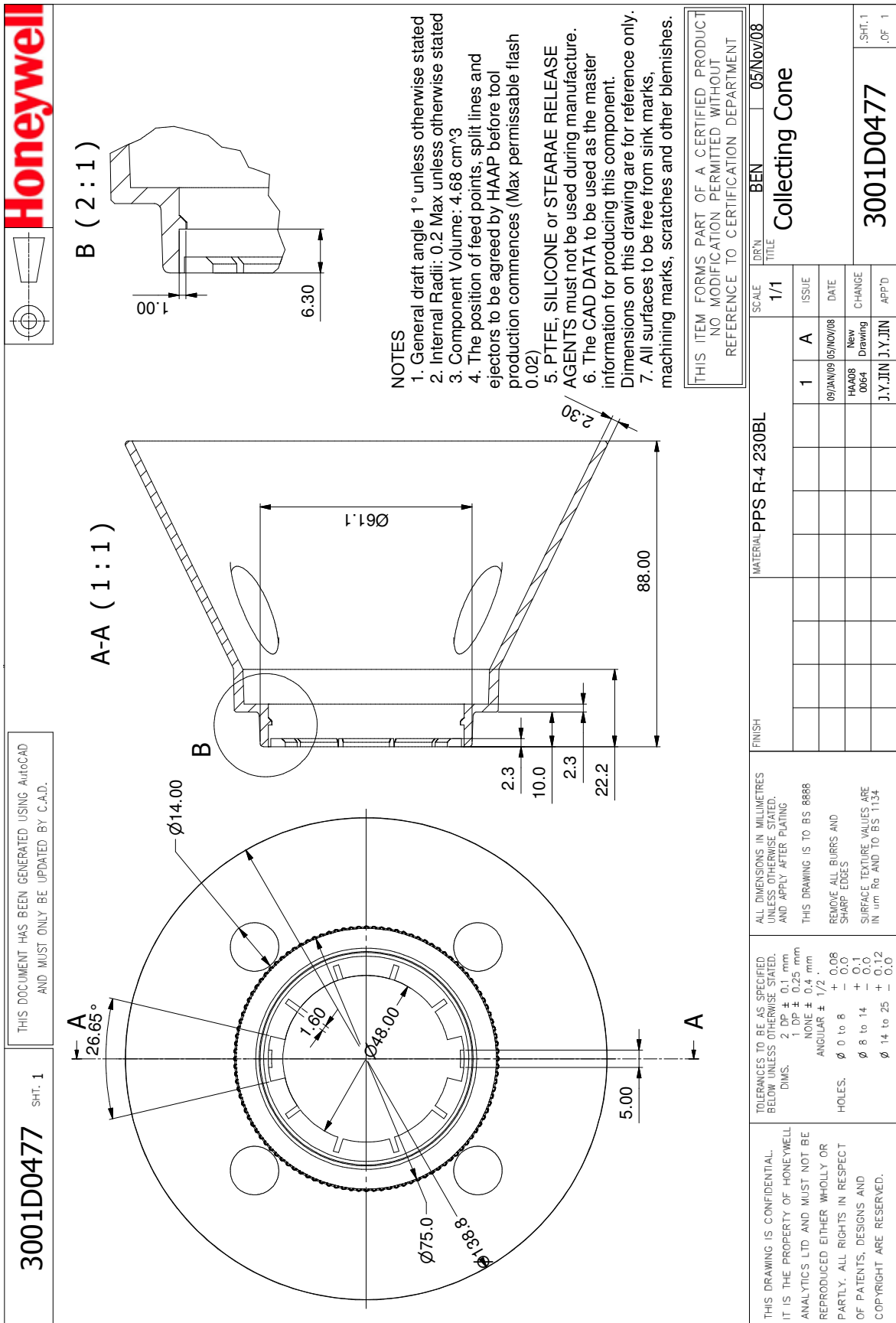
Duct Mounting Hole



THIS ITEM FORMS PART OF A CERTIFIED PRODUCT. NO MODIFICATION PERMITTED WITHOUT REFERENCE TO CERTIFICATION DEPARTMENT.

SCALE		DR'N		BEN		6/25/2008	
NTS		TITLE		Sensepoint XCD		Installation Drawing	
F	E	D	C	B	A	ISSUE	DATE
09/FEB/09	02/OCT/08	13/AUG/08	09/JUL/08	07/JUL/08	-	-	-
Add Terminal Label	Add Code	Change WP	Add Inch dims.	Add Sheet	New Drawing	CHANGE	APPD
J.Y.JIN	J.Y.JIN	J.Y.JIN	J.Y.JIN	J.Y.JIN	J.Y.JIN	J.Y.JIN	J.Y.JIN
FINISH		MATERIAL		SCALE		DR'N	
ALL DIMENSIONS IN MILLIMETRES UNLESS OTHERWISE STATED. AND APPLY AFTER PLATING.				NTS		BEN	
THIS DRAWING IS TO BS 8888 REMOVE ALL BURRS AND SHARP EDGES SURFACE TEXTURE VALUES ARE IN µm Ra AND TO BS 1134				Sensepoint XCD		Installation Drawing	
TOLERANCES TO BE AS SPECIFIED BELOW UNLESS OTHERWISE STATED.				3001G0471		-SHT.3	
DIMS. 2 DP ± 0.1 mm 1 DP ± 0.25 mm NONE ± 0.4 mm ANGULAR ± 1/2						.OF 3	
HOLES. Ø 0 to 8 + 0.08 - 0.0 Ø 8 to 14 + 0.1 - 0.0 Ø 14 to 25 + 0.2 - 0.0							
THIS DRAWING IS CONFIDENTIAL. IT IS THE PROPERTY OF HONEYWELL ANALYTICS LTD. AND MUST NOT BE REPRODUCED EITHER WHOLLY OR PARTLY. ALL RIGHTS IN RESPECT OF PATENTS, DESIGNS AND COPYRIGHT ARE RESERVED.							

17.4 Collecting Cone Drawing



17.5 Mounting Bolt Assy Drawing

3001A0416

SHT. 1

THIS DOCUMENT HAS BEEN GENERATED USING AutoCAD
AND MUST ONLY BE UPDATED BY C.A.D.

M8x1.25 - 6H

M8x1.25 - 6g

13

8

Ø8.0

120

5.30

Ø14.96

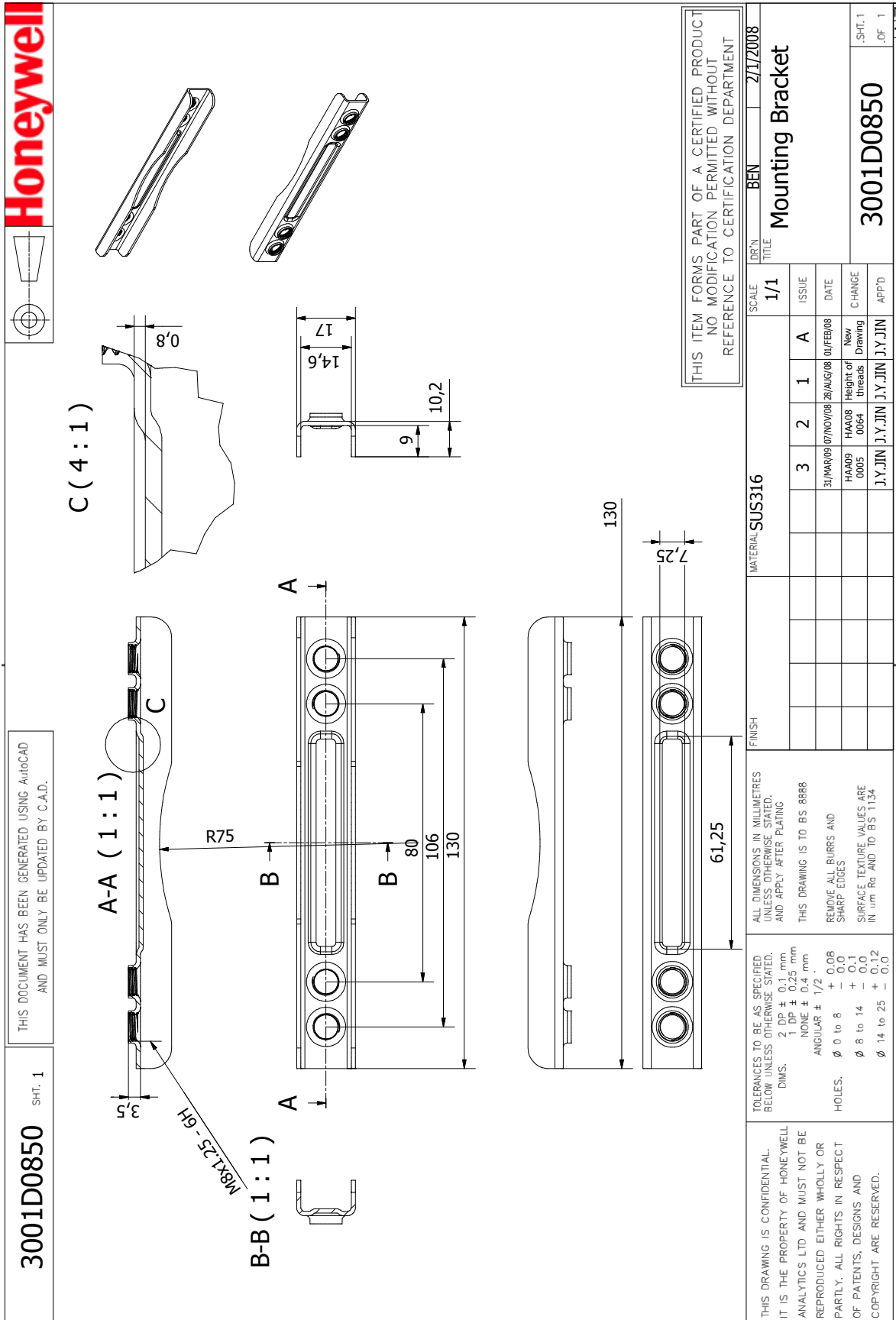
Ø8.36

1.98

THIS ITEM FORMS PART OF A CERTIFIED PRODUCT
NO MODIFICATION PERMITTED WITHOUT
REFERENCE TO CERTIFICATION DEPARTMENT

MATERIAL	316SS					FINISH					
SCALE	2/1					DRN	BEN				
TITLE	Mounting Bolt Assy					DATE	25/Oct/07				
ISSUE	A					CHANGE					
DATE	05/NOV/08					NEW					
CHANGE LENGTH	24/JUN/08					DRAWING					
WASHER DETAIL	07/JUL/08					J.Y.JIN					
DETAIL	06/4					J.Y.JIN					
APPD	J.Y.JIN					J.Y.JIN					
						3001A0416					
						SHT. 1 OF					

17.6 Mounting Bracket Drawing



17.7 Sensepoint XCD RFD Sensor

Sht. 1

THIS DOCUMENT HAS BEEN GENERATED USING AutoCAD AND MUST ONLY BE UPDATED BY C.A.D.

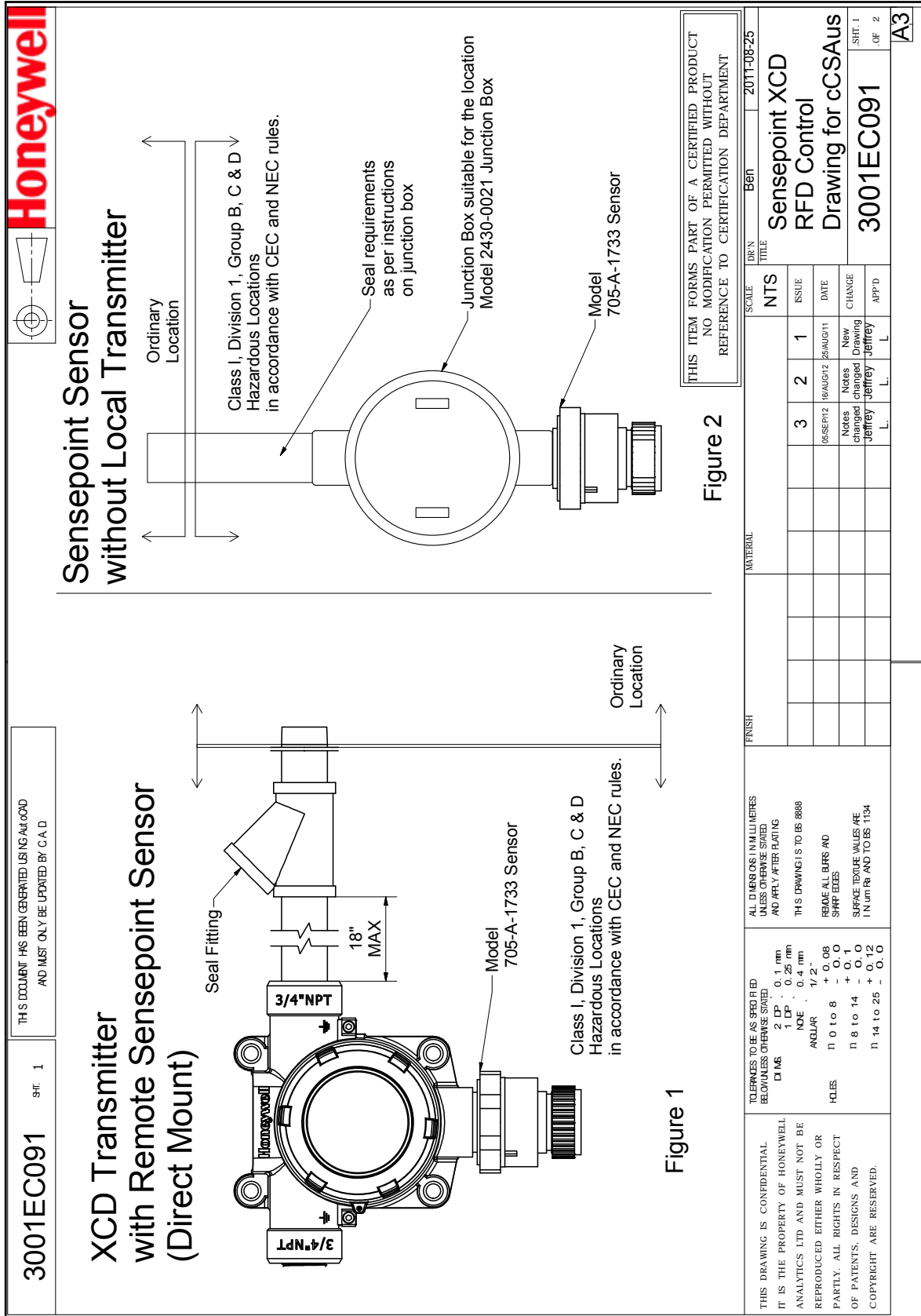
THIS ITEM FORMS PART OF A CERTIFIED PRODUCT
NO MODIFICATION PERMITTED WITHOUT
REFERENCE TO CERTIFICATION DEPARTMENT

SCALE: SA 2:1 DEC-09

TITLE: Sensepoint XCD Remote Sensor Assy Drawing

SCALE	TITLE	MATERIAL	FINISH	ALL DIMENSIONS IN MILLIMETRES UNLESS OTHERWISE STATED. AND APPLY AFTER PLATING	TOLERANCES TO BE AS SPECIFIED BELOW UNLESS OTHERWISE STATED.	THIS DRAWING IS CONFIDENTIAL IT IS THE PROPERTY OF HONEYWELL ANALYTICS LTD AND MUST NOT BE REPRODUCED EITHER WHOLLY OR PARTLY. ALL RIGHTS IN RESPECT OF PATENTS, DESIGNS AND COPYRIGHT ARE RESERVED.
NTS	A			THIS DRAWING IS TO BS 8888 REMOVE ALL DIMS AND SHARP EDGES SURFACE TEXTURE VALUES ARE IN um Ra AND TO BS 1134	DIMS: 2 DP ± 0.1 mm 1 DP ± 0.25 mm NONE ± 0.4 mm ANGULAR ± 1/2° HOLES: Ø 0 to 8 + 0.08 - 0.0 Ø 8 to 14 + 0.1 - 0.0 Ø 14 to 25 + 0.12 - 0.0	
ISSUE	210009					
DATE	NEW DRAWING					
CHANGE	J.Y. JIN					
APP'D						

17.8 Control Drawing





THIS DOCUMENT HAS BEEN GENERATED USING AUTOCAD AND MUST ONLY BE UPDATED BY C.A.D.

3001EC091 SHT. 2

XCD Transmitter and Sensepoint Sensor Remoted.

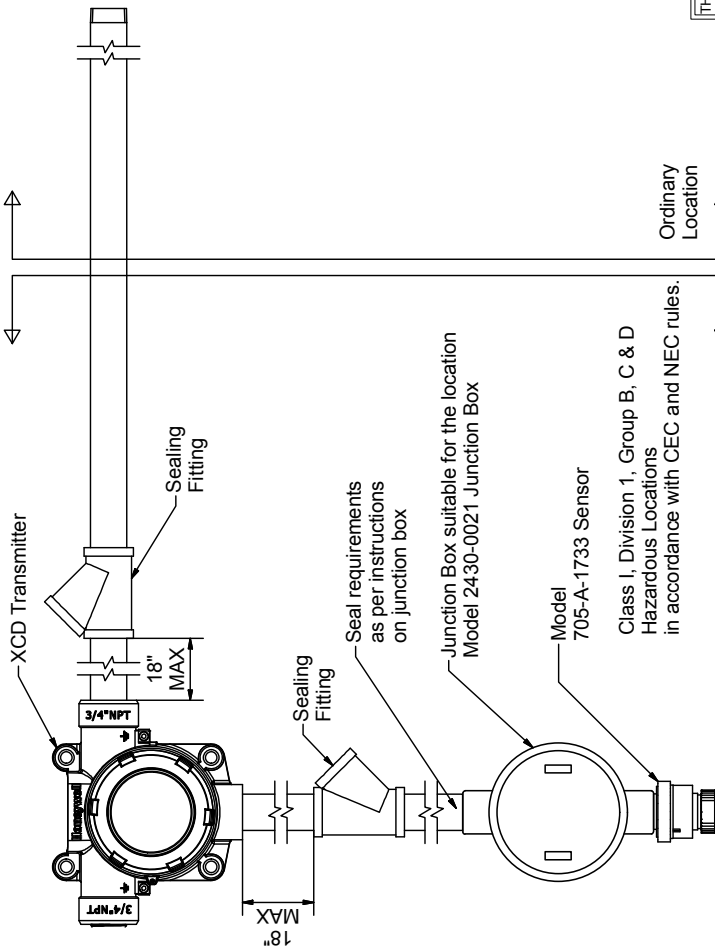


Figure 3


THIS ITEM FORMS PART OF A CERTIFIED PRODUCT
NO MODIFICATION PERMITTED WITHOUT
REFERENCE TO CERTIFICATION DEPARTMENT

THIS DRAWING IS CONFIDENTIAL. IT IS THE PROPERTY OF HONEYWELL ANALYTICS LTD AND MUST NOT BE REPRODUCED EITHER WHOLLY OR PARTLY. ALL RIGHTS IN RESPECT OF PATENTS, DESIGNS AND COPYRIGHT ARE RESERVED.		TO BRACKETS TO BE AS SPECIFIED BELOW UNLESS OTHERWISE SPECIFIED DIMS. 2 D.P. DIMS. 0.1 mm DIMS. 0.25 mm DIMS. 0.4 mm ANGULAR 1/2° HOLE 11.0 to 8 +0.08 HOLE 11.8 to 14 -0.1 HOLE 11.14 to 25 -0.12 HOLE 11.14 to 25 +0.0		ALL DIMENSIONS IN MILLIMETRES UNLESS OTHERWISE SPECIFIED AND APPLY AFTER FINISHING THIS DRAWING IS TO BS 8888 MAKE ALL DIMS AND SHIP BEES SURFACE FINISH VALUES ARE IN UNITS AND TO BS 1134		FINISH		MATERIAL		SCALE NTS		DRN B66		TITLE Sensepoint XCD RFD Control Drawing for cCSAus		2011-08-25	
								3 2 1		05SEP12 18AUG12 25AUG11		DATE		ISSUE			
										Notes changed Drawing Jeffrey Jeffrey Jeffrey		CHANGE		APP'D			
										SHT. 2 OF 2		3001EC091		A3			

18 Certification

18.1 China GB Ex and PA

China GB Ex (Chinese Version):



防 爆 合 格 证

证号: GYJ081072X

由 **霍尼韦尔探测器亚太有限公司** 制造的产品:
(地址: 508 Korea Science Valley(H 187-10 Guro-dong, Guro-Gu Seoul, 152-050, Korea)

名 称 **可燃气体探测器**

型号规格 **Sensepoint XCD**


防爆标志 **Ex d II CT4**

产品标准 **I**

图样编号 **3001EG026、3001EG027**

经图样及技术文件的审查和样品检验, 确认上述产品符合 **GB 3836.1-2000、GB 3836.2-2000** 标准, 特颁发此证。有效期自颁发日期起 **伍** 年内有效。

备注 产品使用安全注意事项见防爆合格证附件 I。

站长 


国家级仪器仪表防爆安全监督检验站

颁发日期 **二〇〇八** 年 **七** 月 **二十五** 日

本证书仅对与认可文件和样品一致的产品有效。

地址: 上海市漕宝路103号	网址: www.nepsi.org.cn	电话: 0086 21 64368180
邮编: 200233	Email: info@nepsi.org.cn	传真: 0086 21 64844580

China GB Ex (English Version):




EXPLOSION PROTECTION CERTIFICATE OF CONFORMITY

Cert No. GYJ081072X

This is to certify that the product
Gas Detector
manufactured by Honeywell Analytics AP
 (Address: 508 Kolon Science Valley(I) 187-10 Guro-dong,
 Guro-Gu Seoul, 152-050, Korea)
which model is Sensepoint XCD
Ex marking Ex d II CT4
product standard /
drawing number 3001EG026, 3001EG027

has been inspected and certified by NEPSI, and that it conforms
to GB3836.1-2000 GB3836.2-2000
This Approval shall remain in force until 2013.07.24
Remarks Special conditions for safe use specified in the attachment 1 to this certificate.


Director 

National Supervision and Inspection Centre for
 Explosion Protection and Safety of Instrumentation
 Issued Date 2008.07.25

This Certificate is valid for products compatible with the documents and samples approved by NEPSI.

103 Cao Bao Road Shanghai 200233, China	http://www.nepsi.org.cn Email: info@nepsi.org.cn	Tel:0086 21 64368180 Fax:0086 21 64844580
--	---	--

China PA Certification:



中 华 人 民 共 和 国

计 量 器 具 型 式 批 准 证 书

PATTERN APPROVAL CERTIFICATE OF THE MEASURING INSTRUMENTS OF THE PEOPLE'S REPUBLIC OF CHINA

韩国 Honeywell Analytics AP _____ :

根据《中华人民共和国计量法》及相关规定和技术要求,下列计量器具经定型鉴定合格,现予批准。

According to the Law on Metrology of the People's Republic of China and the relevant regulations, the pattern of measuring instruments applied for pattern approval have been approved.

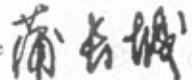
计量器具名称及型号:
Name and type of the measuring instruments:


气体检测仪 (Sensepoint XCD 型)
规格:CO (0-500) $\mu\text{L/L}$ CH₄ (0-100) %LEL
注:本次评价试验仪包含 CO, CH₄ 两种气体

计量器具的技术指标见型式注册表。
The technical specifications of the measuring instruments are described in the pattern registration list.

型式批准的标志与编号:
The mark and identification numbers of the pattern approval:

批准人
Approval signature






2008-C285



批准部门
Approval authority

批准日期 二〇〇八年十月八日
Approval date

批准时的附件:
1. 计量器具型式评价报告
2. 型式注册证
3. 型式评价大纲
(其他)



18.2 Korea KTL

제2013-019938-02호


안 전 인 증 서

한국하니웰(주) 천안공장
충청남도 천안시 서북구2공단2로 28 (성성동)

위 사업장에서 제조하는 아래의 품목이 「산업안전보건법」 제34조 및 같은 법 시행규칙 제58조의4제4항에 따른 안전인증 심사 결과 안전·보건기준에 적합하므로 안전인증표시의 사용을 인증합니다.

	품 목	
	설치용 가스탐지기	
	형식·모델(용량·등급) / 인증번호	
	Sensepoint XCD Transmitter (Ex d IIC T6/T4) / 13-KB2BO-0407	
	인 증 기 준	
	고용노동부고시 제2010-36호	
	인 증 조 건	
1. 제조공장	본 인증서는 '충청남도 천안시 서북구2공단2로 28 (성성동)'에서 생산하는 제품에 한함	
2. 제품개요	제품정격: 최대 32 V, 3.5 W 사용주위온도: $-40\text{ }^{\circ}\text{C} \leq T_a \leq +65\text{ }^{\circ}\text{C}$ (for T6) / $+75\text{ }^{\circ}\text{C}$ (for T4)	
3. 인증범위	본 인증서는 위의 형식에 한하여 유효함	
4. 안전한 사용을 위한 조건	없음	
5. 인증(변경)사항	없음	
6. 그 밖의 사항	없음	

2013 년 7 월 18 일



한국산업기술시험원장

FP251-8

152-718 서울특별시 구로구 구로동 222-13 <http://www.ktl.re.kr>

18.3 European ATEX

ATEX For Transmitter:

Certificate Number
Baseefa08ATEX0222



Issued 31 October 2008
Page 1 of 2

- 1 EC - TYPE EXAMINATION CERTIFICATE**
- 2 Equipment or Protective System Intended for use in Potentially Explosive Atmospheres
Directive 94/9/EC**
- 3 EC - Type Examination Certificate Number: Baseefa08ATEX0222**
- 4 Equipment or Protective System: A Type XCD Transmitter**
- 5 Manufacturer: Honeywell Analytics**
- 6 Address: 405 Barclay Boulevard, Lincolnshire, IL 60069, USA.**
- 7 This equipment or protective system and any acceptable variation thereto is specified in the schedule to this certificate and the documents therein referred to.**
- 8 Baseefa, Notified Body number 1180, in accordance with Article 9 of the Council Directive 94/9/EC of 23 March 1994, certifies that this equipment or protective system has been found to comply with the Essential Health and Safety Requirements relating to the design and construction of equipment and protective systems intended for use in potentially explosive atmospheres given in Annex II to the Directive.**
- The examination and test results are recorded in confidential Report No. **GB/BAS/ExTR08.0149/00**
- 9 Compliance with the Essential Health and Safety Requirements has been assured by compliance with:**
IEC60079-0: 2007 EN60079-1: 2007 EN 61241-1: 2006
- except in respect of those requirements listed at item 18 of the Schedule.
- 10 If the sign "X" is placed after the certificate number, it indicates that the equipment or protective system is subject to special conditions for safe use specified in the schedule to this certificate.**
- 11 This EC - TYPE EXAMINATION CERTIFICATE relates only to the design and construction of the specified equipment or protective system. Further requirements of the Directive apply to the manufacturing process and supply of this equipment or protective system. These are not covered by this certificate.**
- 12 The marking of the equipment or protective system shall include the following :**
⊕ II GD Ex d IIC Gb T6 (Ta -40°C to +65°C) Ex tb IIC T85°C Db IP66
- This certificate may only be reproduced in its entirety, without any change, schedule included.

Baseefa Customer Reference No. **5989**

Project File No. **08/0201**

This certificate is granted subject to the general terms and conditions of Baseefa. It does not necessarily indicate that the equipment may be used in particular industries or circumstances.

Baseefa
Rockhead Business Park, Staden Lane,
Buxton, Derbyshire SK17 9RZ
Telephone +44 (0) 1298 766600 Fax +44 (0) 1298 766601
e-mail info@baseefa.com web site www.baseefa.com
Baseefa is a trading name of Baseefa Ltd
Registered in England No. 4305578. Registered address as above.

DBewley
PP DBREARLES
R S SINCLAIR
DIRECTOR
On behalf of
Baseefa

ATEX for Sensor

Certificate Number
Baseefa08ATEX0316X



Issued 9 March 2009
Page 1 of 2

1 EC - TYPE EXAMINATION CERTIFICATE

2 Equipment or Protective System Intended for use in Potentially Explosive Atmospheres
Directive 94/9/EC

3 EC - Type Examination Certificate Number: **Baseefa08ATEX0316X**

4 Equipment or Protective System: **A Type XCD Gas Sensor Head**

5 Manufacturer: **Honeywell Analytics Inc.**

6 Address: **405 Barclay Boulevard, Lincolnshire, IL 60069, USA.**

7 This equipment or protective system and any acceptable variation thereto is specified in the schedule to this certificate and the documents therein referred to.

8 Baseefa, Notified Body number 1180, in accordance with Article 9 of the Council Directive 94/9/EC of 23 March 1994, certifies that this equipment or protective system has been found to comply with the Essential Health and Safety Requirements relating to the design and construction of equipment and protective systems intended for use in potentially explosive atmospheres given in Annex II to the Directive.

The examination and test results are recorded in confidential Report No. **GB/BAS/ExTR08.0220/00**

9 Compliance with the Essential Health and Safety Requirements has been assured by compliance with:

IEC 60079-0: 2007

EN 60079-1: 2007

EN 61241-1: 2004

except in respect of those requirements listed at item 18 of the Schedule.

10 If the sign "X" is placed after the certificate number, it indicates that the equipment or protective system is subject to special conditions for safe use specified in the schedule to this certificate.

11 This EC - TYPE EXAMINATION CERTIFICATE relates only to the design and construction of the specified equipment or protective system. Further requirements of the Directive apply to the manufacturing process and supply of this equipment or protective system. These are not covered by this certificate.

12 The marking of the equipment or protective system shall include the following :

Ex II 2 GD Ex d IIC T6 (Ta -40°C to +65°C) Gb Ex tb IIIC T85°C Db IP6X A21

This certificate may only be reproduced in its entirety, without any change, schedule included.

Baseefa Customer Reference No. **5989**

Project File No. **08/0261**

This certificate is granted subject to the general terms and conditions of Baseefa. It does not necessarily indicate that the equipment may be used in particular industries or circumstances.

R S SINCLAIR

DIRECTOR



On behalf of

Baseefa


Baseefa
Rockhead Business Park, Staden Lane,
Buxton, Derbyshire SK17 9RZ
Telephone +44 (0) 1298 766600 Fax +44 (0) 1298 766601
e-mail info@baseefa.com web site www.baseefa.com
Baseefa is a trading name of Baseefa Ltd
Registered in England No. 4305578. Registered address as above.

18.4 International IEC

IEC Ex for Transmitter

		<h1>IECEX Certificate of Conformity</h1>	
INTERNATIONAL ELECTROTECHNICAL COMMISSION IEC Certification Scheme for Explosive Atmospheres <small>for rules and details of the IECEx Scheme visit www.iecex.com</small>			
Certificate No.:	IECEX BAS 08.0072	issue No.:1	Certificate history: Issue No. 1 (2009-12-8) Issue No. 0 (2008-11-10)
Status:	Current		
Date of Issue:	2009-12-08	Page 1 of 4	
Applicant:	Honeywell Analytics 405 Barclay Boulevard Lincolnshire Illinois 60069 United States of America		
Electrical Apparatus: <i>Optional accessory:</i>	A Type XCD Transmitter		
Type of Protection:	Flameproof		
Marking:	Ex d IIC Gb T6 (Ta -40°C to +65°C) Ex tb IIC T85°C Db IP66		
Approved for issue on behalf of the IECEx Certification Body:	R S Sinclair		
Position:	Managing Director		
Signature: <i>(for printed version)</i>	_____		
Date:	_____		
1. This certificate and schedule may only be reproduced in full. 2. This certificate is not transferable and remains the property of the issuing body. 3. The Status and authenticity of this certificate may be verified by visiting the Official IECEx Website.			
Certificate issued by: <div style="display: flex; justify-content: space-between; align-items: center;"> <div style="text-align: center;"> <p>Baseefa Rockhead Business Park Staden Lane Buxton Derbyshire SK17 9RZ United Kingdom</p> </div> <div style="text-align: center;">  </div> </div>			

IEC Ex for Sensor

		<h1 style="text-align: center;">IECEX Certificate of Conformity</h1>	
INTERNATIONAL ELECTROTECHNICAL COMMISSION IEC Certification Scheme for Explosive Atmospheres <small>for rules and details of the IECEx Scheme visit www.iecex.com</small>			
Certificate No.:	IECEX BAS 08.0104X	Issue No.:	0
Status:	Current		
Date of Issue:	2009-03-09	Page 1 of 3	
Applicant:	Honeywell Analytics 405 Barclay Boulevard Lincolnshire Illinois 60069 United States of America		
Electrical Apparatus:	A Type XCD Gas Sensor Head		
Optional accessory:			
Type of Protection:	Flameproof and Dust		
Marking:	Ex d IIC T6 (Ta -40°C to +65°C) Gb Ex tb IIIC T85°C Db IP6X A21		
Approved for issue on behalf of the IECEx Certification Body:	R S Sinclair		
Position:	Managing Director		
Signature: (for printed version)			
Date:			
1. This certificate and schedule may only be reproduced in full. 2. This certificate is not transferable and remains the property of the issuing body. 3. The Status and authenticity of this certificate may be verified by visiting the Official IECEx Website .			
Certificate issued by:	Baseefa Rockhead Business Park Staden Lane Buxton Derbyshire SK17 9RZ United Kingdom		
			

18.5 Sensepoint XCD RFD cCSAus Name Plate

3001EC090 SHT. 1

THIS DOCUMENT HAS BEEN GENERATED USING
ACD/CBE ILLUSTRATOR AND MUST ONLY BE UPDATED BY A.I.

Honeywell Sensepoint XCD RFD

Honeywell Analytics Inc. Lincolnshire, IL, USA 60069

For use with integral or remote model 705-A-1733 sensor when installed per drawing No.3000EC091, Class I, Division 1, Groups B, C & D. Read Sensepoint XCD/ RFD manual prior to use.

Temp. Code T4, 12-32Volts DC, Pmax=5W,
Tamb: -40°C to +65 °C, C22.2 No. 152, ISA 12.13.01
Ex d IIIC T6 Gb Lire et comprendre le manuel.
Ex tb IIIC T85 °C Db **Segurança**
IP66 **ATENÇÃO - NÃO ABRA QUANDO ENERGIZADO**
Tamb: -40°C a +65 °C **WARNING** : To reduce the risk of Hazardous Atmospheres, Disconnect the equipment from supply circuit before opening. Keep tightly closed when in operation. Conduit runs must have a seal fitting within 18 inches of the enclosure.
GARDER Couvrir hermétiquement **Made in Korea**
fermé lors du fonctionnement

P/N : _____
S/N : _____

Honeywell Sensepoint XCD RFD

Honeywell Analytics Inc. Lincolnshire, IL, USA 60069

For use with integral or remote model 705-A-1733 sensor when installed per drawing No.3000EC091, Class I, Division 1, Groups B, C & D. Read Sensepoint XCD/ RFD manual prior to use.

Temp. Code T4, 12-32Volts DC, Pmax=5W,
Tamb: -40°C to +65 °C, C22.2 No. 152, ISA 12.13.01
Ex d IIIC T6 Gb Lire et comprendre le manuel.
Ex tb IIIC T85 °C Db **Segurança**
IP66 **ATENÇÃO - NÃO ABRA QUANDO ENERGIZADO**
Tamb: -40°C a +65 °C **WARNING** : To reduce the risk of Hazardous Atmospheres, Disconnect the equipment from supply circuit before opening. Keep tightly closed when in operation. Conduit runs must have a seal fitting within 18 inches of the enclosure.
GARDER Couvrir hermétiquement **Made in Korea**
fermé lors du fonctionnement

P/N : _____
S/N : _____

THIS ITEM FORMS PART OF A CERTIFIED PRODUCT
NO MODIFICATION PERMITTED WITHOUT
REFERENCE TO CERTIFICATION DEPARTMENT

SCALE		DR'N BEN		TITLE	
SCALE	DR'N BEN	TITLE	SCALE	DR'N BEN	TITLE
5	3001EC090	Changed Design	2	1	Sensepoint XCD RFD
4	1000016	Changed Design	3	1	cCSAus Name Plate
3	1000016	Changed Design	4	1	3001EC090
2	1000016	Changed Design	5	1	Sensepoint XCD RFD
1	1000016	Changed Design	6	1	cCSAus Name Plate
DATE		ISSUE	SHT. 1 OF 1		
10/03/12		25/AUG/11			
ACTIONED BY		Jeffrey L. Jeffrey			

18.6 Sensor Cartridges Label

3001EA053 SHT. 1

THIS DOCUMENT HAS BEEN GENERATED USING ADOBE ILLUSTRATOR AND MUST ONLY BE UPDATED BY A.I.

CE₀₃₄₄ Honeywell Analytics Inc.
Lincolnshire, IL, USA 60069
Sensepoint XCD Disposable Sensor
Rev.

P/N :
S/N : **SI PPPPPYY W WNNNN**

Revision Number

Gas Type

Ex

II 2 GD
Ex d IIC T6(Ta -40°C to +65°C) Gb
Ex tb IIC T85°C Db IP66 A21
BaseEx IIC T85°C Db IP66 A21
BaseEx IIC T85°C Db IP66 A21
IECEx BAS 08.0104X
Max. Rating: 4.0V, 250mA, 1W
WARNING: DO NOT SEPARATE WHEN ENERGISED

NOTE
1. LEGEND TO BE THERMALLY TRANSFER PRINTED IN BLACK ONTO BLANK LABEL.

SERIAL NUMBER EXAMPLE:
S/N: SI PPPPPYY W WNNNN

SUPPLIER CODE

— Week of MFG

— Sequence number

— Part Code

— Year of MFG

— Issue State

THIS ITEM FORMS PART OF A CERTIFIED PRODUCT
NO MODIFICATION PERMITTED WITHOUT REFERENCE TO CERTIFICATION DEPARTMENT

DRAWING TITLE		SCALE		DRAWING		BEN/HUR		12/SEP/08	
Sensor Cartridge Label Artwork Drawing		MTS	ISSUE	DATE	APPROVED BY				
		3	2	1	A	10/NOV/08	12/SEP/08		
		Change IP Grade	ADD NOTE	REVISED DRAWING	NEW DRAWING	J.Y.JIN	J.Y.JIN	J.Y.JIN	J.Y.JIN

Adhesive: Acrylic

MATERIAL: Matt metallized PET 50um

THIS DRAWING IS CONFIDENTIAL. IT IS THE PROPERTY OF HONEYWELL ANALYTICS LTD AND MUST NOT BE REPRODUCED EITHER WHOLLY OR PARTLY. ALL RIGHTS IN RESPECT OF PATENTS, DESIGNS AND COPYRIGHT ARE RESERVED.

3001EA053 SHT. 1
OF 1

19 Cross Interference and Cross Calibration

19.1 Cross Calibration Flammable Gas Detector

For greater accuracy, a catalytic gas detector should be calibrated using a certified gas/air mixture equal to 50% LEL of the actual target gas intended to be monitored.

However, it is not always practical to obtain every detectable type of hydrocarbon gas in a calibration-ready, certified and verifiable form. Therefore, it is possible to carry out a “cross calibration” using another hydrocarbon gas/air mixture.

When the Sensepoint XCD Combustible LEL sensor is to be calibrated with a gas which is different to the gas or vapour to be detected, the following cross calibration procedure may be followed:

Caution: Where the user calibrates any sensor using a different gas, responsibility for identifying and recording calibration rests with the user. Refer to the local regulations where appropriate.

Notes:

1. Table 14 lists a selection of hydrocarbon compounds and states a reference figure or “Star Rating” according to the reaction they produce in relation to other hydrocarbons.
2. An eight star (8*) gas produces the highest output, while a one star (1*) gas produces the lowest output.

No.	Gas	Star Rating
1	Acetone	4*
2	Ammonia	7*
3	Benzene	3*
4	Butanone	3*
5	Butane	4*
6	Butyl acetate	1*
7	Butyl acrylate	1*
8	Cyclohexane	3*
9	Cyclohexanone	<1*
10	Diethyl ether	4*
11	Ethane	6*
12	Ethanol	5*
13	Ethyl acetate	3*
14	Ethylene	5*
15	Heptane	3*
16	Hexane	3*
17	Hydrogen	6*
18	Methane	6*
19	Methanol	5*
20	MIBK	3*
21	Octane	3*

22	Pentane	3*
23	Propane	5*
24	Propan-2-ol	4*
25	Styrene	2*
26	Tetra hydrafuran	4*
27	Toluene	3*
28	Triethylamine	3*
29	Xylene	2*

Table 14 . Star Rating of Gases

To cross calibrate the Sensepoint XCD flammable gas detector:

- (1) Obtain the star rating for both the calibration test gas and the gas to be detected from Table 14
- (2) These values may then be used in Table 15 to obtain the required calibration span setting when a 50% LEL test gas is applied to the detector.

*Rating of Calibration Gas	*Rating of Gas to be Detected							
	8*	7*	6*	5*	4*	3*	2*	1*
8*	50	62	76	95	-	-	-	-
7*	40	50	61	76	-	-	-	-
6*	33	41	50	62	78	-	-	-
5*	26	33	40	50	63	79	-	-
4*	-	26	32	40	50	63	80	-
3*	-	-	26	32	40	50	64	81
2*	-	-	-	25	31	39	50	64
1*	-	-	-	-	25	31	39	50

Note: These settings must only be used with a calibration gas concentration of 50% LEL.

Table 15. Calibration span setting

- (3) If a sensor is to be used to detect a gas other than that for which it was calibrated and there is no intention to use an equivalent calibration gas to re-calibrate the sensor, then the required correction factor may be obtained from Table 16.

The reading shown on the gas detector controller or transmitter display should be multiplied by this number in order to obtain a more accurate gas concentration result.

Sensor calibrated to detect	Sensor used to detect							
	8*	7*	6*	5*	4*	3*	2*	1*
8*	1.00	1.24	1.52	1.89	2.37	2.98	3.78	4.83
7*	0.81	1.00	1.23	1.53	1.92	2.40	3.05	3.90
6*	0.66	0.81	1.00	1.24	1.56	1.96	2.49	3.17
5*	0.53	0.66	0.80	1.00	1.25	1.58	2.00	2.55
4*	0.42	0.52	0.54	0.80	1.00	1.26	1.60	2.03
3*	0.34	0.42	0.51	0.64	0.80	1.00	1.27	1.62
2*	0.26	0.33	0.40	0.50	0.63	0.79	1.00	1.28
1*	0.21	0.26	0.32	0.39	0.49	0.62	0.78	1.00

Table 16. Correction factors

Notes:

1. *Since catalytic sensors require oxygen for correct operation, a mixture of gas in air should always be used for calibration purposes.*
2. *Assuming average performance of the sensor, the sensitivity information in Tables 14 To 16 is normally accurate to + or - 30%.*

Working Example:

If the target gas to be detected is 0-100%LEL Ethylene and the only calibration gas available to re-calibrate the sensor is Methane (at 50% LEL concentration), the procedure is as follows:

- (1) Look up the star rating for each gas in Table 14:

Gas No. 14, Ethylene = 5*
Gas no. 18, Methane = 6*

- (2) Then, look up the span settings for a 50% LEL calibration gas in Table 15 by selecting the row of figures next to the 6* in the "calibration gas" column. Select the figure in the 5* column of the "gas to be detected" section. The figure is 62.

- (3) This means that during re-calibration, the span gas setting on the gas detector transmitter or controller should be set to 62% LEL to give an accurate measuring scale for 0-100%LEL Ethylene, when using 50% LEL Methane as the calibration gas.

Section 19.1 is used for Sensepoint XCD Catalytic Sensor only, please refer to Sensepoint Technical Manual for using Sensepoint flammable gas sensors.

Please contact your local Honeywell Analytics sales or service distributor, or regional office should further clarification or additional information be required.

19.2 Meter Multiplication Factors for Sensepoint XCD-IR Propane

It is possible to apply a linear cross reference factor to the output of a sensor characterized for propane and achieve the results shown in the graph below.

Reasonable accuracy is maintained to at least the 50% LEL equivalent values of the cross-referred gasses.

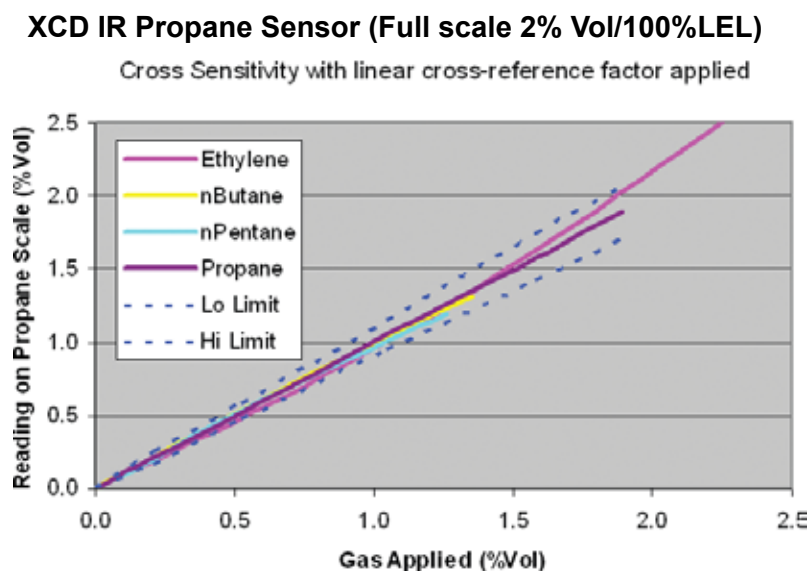


Diagram 18. Sensepoint XCD-IR (Propane) Sensor with linear cross-reference factor applied

Use the following multiplying factors to cross-refer to the propane reading:

Gas	Multiplication Factor
Ethylene	3.43
nButane	0.97
nPentane	0.89

Table 17. Multiplying Factors

Caution: These factors only apply to gas concentrations expressed in % Volume terms. When using a linear cross reference factor the temperature compensation is based upon propane, and there may be errors at temperatures away from the calibration temperature.

NOTE

Honeywell Analytics recommends that users verify the accuracy of their instruments using test gasses wherever possible. Cross-referred measurements should be used as a guide only, not as absolute values.

XCD Transmitter

Appendix A - Modbus® Protocol A-2

A.1 Modbus and the XCD

The XCD gas detector may be fitted with the optional Modbus board. Authoritative information on the MODBUS Upgrade Kit can be found at www.modbus.org. The XCD supports Modbus/RTU over an RS-485 physical layer. The interface is isolated and includes a switchable 120 Ohm termination resistor. Baud rates 9600 or 19,200 are supported with 19,200 as the default. Most of the operations that are possible with local user interfaces can also be performed using the Modbus interface. This includes configuration operations. However, this Appendix only describes how to monitor XCD status using Modbus.

See Section 4.1.1 for information on installing the optional Modbus hardware. See Section 4.1.1 Configure Menu – Set ID Settings for information on setting the Modbus baud rate and Parity using the local user interface.

A.2 Modbus Registers

ModBus Register Address	Information	R/W	Type	Size	Note
30001	Main SW Version of XCD	R	u8	1	
30002	EEP Version of XCD	R	u8	1	
30003	WatchDog s/w Version of XCD	R	u8	1	
30004	Location string	R	string[12]	6	
30010	ModBus slave ID	R	u8	1	
30011	Monitor Status	R	u16	1	Upper byte : Function Lower byte : Instrument Mode
30012	Inhibit current(mA)	R	u8	1	20 means 2.0mA
30013	Reserved	R	u16	1	
30014	Active Alarm	R	u32	2	bit 0 Alarm 1 is active bit 1 Alarm 2 is active
30016	Latched Alarm	R	u32	2	bit 0 Alarm 1 is active bit 1 Alarm 2 is active
30018	Active Fault	R	u32	2	Upper Byte: fault Lower Byte:warning Bit 0:W1~Bit 6:W6 Bit 7:F1~Bit 11:F5
30020	Latched Fault	R	u32	2	Upper Byte: fault Lower Byte:warning Bit 0:W1~Bit 6:W6 Bit 7:F1~Bit 11:F5
40001	System ID code	R	u16	1	Upper Byte : Type Code : 0x25 Lower Byte : My Address
40002	System ID code	R	u16	1	Upper Byte : Type Code : 0x25 Lower Byte : My Address : Dummy Spacer
40003	Gas reading	R	f32	2	
40005	Fault and Warning	R	u8	1	Fault = 1100 + Number Warning = Number as is
40006	Alarm, fault and warning state	R	u8	1	bit 0 Alarm 1 is active bit 1 Alarm 2 is active bit 2,3 for future expansion bit 4 Warning is active bit 5 Fault is active bit 6,7 for future expansion Note: Latching relay setting latches Modbus values in register 40006.
40007	Monitor state monitoring	R	u8	1	1 : Normal 2 : Warm Up after power on 3 : Inhibit 12 : Calibration
40008	Reserved	R	u16	1	
40009	Ca liberation Due	R	f32	2	
40011	Measuring Unit	R	u8	1	4 : PPM 3 : %Vol 5 : %LEL 1 : mg/m3
40012	Peak Reading	R	f32	2	Peak Reading
40014	Reserved	R	u16	3	
40017	Temperature (°C)	R	s16	1	
40018	Reserved	R	u16	28	
40046	Measuring Gas name string	R	string[14]	7	
40053	Reserved	R	s16	1	
40054	Temperature (°F)	R	s16	1	
40055	Reserved	R	u16	1	
40056	Relay Status	R	u8	1	1 : Energized, 0 : De-energized
40057	Power Supply	R	f32	2	
40059	Calibration Interval	R/W	u16	1	
40060	Alarm Type	R/W	u8	1	High nibble : Alarm 2 Type Low nibble : Alarm 1 Type 0: Disable, 1: Rising, 2:Falling
40061	Inhibit timeout	R/w	u16	1	
40062	Relay configuration	R/w	u8	1	Bit: 0 ~ 2: Relay Type1 ~ Relay Type3 Bit: 3~5 : Relay Sstatus1 ~ Relay Status 3 Bit: 6 : Relay Latch Status

