



**General Monitors**

by MSA

# MODEL S4100C

Hydrocarbon Smart Transmitter



The information and technical data disclosed in this document may be used and disseminated only for the purposes and to the extent specifically authorized in General Monitors in writing. Such information and technical data are proprietary to General Monitors and may not be used or disseminated except as provided in the foregoing sentence.

**Instruction Manual**

**01/18**

General Monitors reserves the right to change published specifications and designs without prior notice.

**Part No.**  
**Revision**

**MANS4100C-EU**  
**Q/01-18**



# DECLARATION OF CONFORMITY



We, at General Monitors Inc, hereby declare that the equipment described below, both in its basic design and construction, and in the version or versions marketed by us, conforms to the relevant safety and health related requirements of the appropriate EU Directives, only as follows:

**General Monitors Ireland**  
Ballybrit Business Park  
Galway, Ireland  
Telephone: +353-91-751175  
[www.MSAafety.com/detection](http://www.MSAafety.com/detection)

## MODEL S4100T

- a) Conform to the protection requirements of EMC Directive 2014/30/EU  
Report Numbers EM01006462. ITS Testing and Certification Ltd. ITS House, Cleeve Road, Leatherhead Surrey KT22 7SB, England  
Relevant Standards:  
EN 50270  
EN55011: ENV50204  
EN 61000-4-2: EN 61000-4-4: EN 61000-4-6  
EN 61000-4-3: EN 61000-4-5: EN 61000-4-8
- b) Sira Certification Service, notified body number 0518 in accordance with Directive 2014/34/EU, certifies that this equipment has been found to comply with the Essential Health and Safety Requirements relating to the design and construction of equipment intended for use in potentially explosive atmospheres given in Annex II to the Directive. Certificate No. 99ATEX3180.

Relevant standards:  
EN60079-0:2009  
EN60079-7:2007  
EN60079-18:2009

This declaration shall cease to be valid if modifications are made to the equipment without our approval.

### PRODUCT: S4100T Intelligent Sensor H<sub>2</sub>S Gas

It is ensured through internal measures and our ISO9001: 2008 certifications, and the requirement for compliance with QAN/QAR as issued by Sira, that series production units conform at all times to the requirements of these current EU Directives and relevant standards.

General Monitors Ireland Ltd. in order to comply with ATEX, will provide this Instruction Manual in a European Language required to operate the product upon request. Should this be necessary, General Monitors Ireland Ltd. should be notified of this request to allow adequate time to process the request.

### ATEX Certificate Markings.

 II 2 G      SIRA 99ATEX3180

 0518      Ex emd IIC T5 Gb      Ex emd IIC T4 Gb  
Ta -40°C to +55°C      Ta -40° C to +70°C

Responsible Person: \_\_\_\_\_ Date: 15-09-16

  
\_\_\_\_\_  
**Cecil Lenihan**  
Business Leader, Galway, Ireland

*The signatory acts on behalf of company management, and with full power of attorney*



## Warranty Statement

General Monitors warrants the Model S4100C to be free from defects in workmanship or material under normal use and service within two (2) years from the date of shipment. General Monitors will repair or replace without charge any equipment found to be defective during the warranty period. Full determination of the nature of, and responsibility for, defective or damaged equipment will be made by General Monitors' personnel. Defective or damaged equipment must be shipped prepaid to General Monitors' plant or the representative from which shipment was made. In all cases this warranty is limited to the cost of the equipment supplied by General Monitors. The customer will assume all liability for the misuse of this equipment by its employees or other personnel. All warranties are contingent upon proper use in the application for which the product was intended and do not cover products which have been modified or repaired without General Monitors' approval or which have been subjected to neglect, accident, improper installation or application, or on which the original identification marks have been removed or altered. Except for the express warranty stated above, General Monitors disclaims all warranties with regard to the products sold, including all implied warranties of merchantability and fitness and the express warranties stated herein are in lieu of all obligations or liabilities on the part of General Monitors for damages including, but not limited to, consequential damages arising out of/or in connection with the use or performance of the product.

## Warnings

High off scale readings may indicate an explosive concentration of gas at the sensor.

A subsequent fall in indicated gas concentration does not imply that safe working conditions have been restored.

Install and maintain all hazardous area equipment in accordance with the relevant regulations and practices of the country concerned. See Section 3 Installation and Section 5 Maintenance.

The S4100C must be protected by in-line 1A PC> 1500A Char "T" fuse (required if voltage at unit is between 10VDC and 35VDC) or a 500mA fuse (required if voltage at unit is between 18VDC and 35VDC) in the 24 VDC supply line. This is necessary to fully comply with approval requirements and good installation practices.

**NOTE:** General Monitors series of Trip Amplifiers have the 500mA fuse as standard. Where application requires 1A fuse, then this must be replaced at time of installation.

The S4100C must be protected by an in-line 63mA; PC> 1500A Char "F" fuse in the analogue output line. This is necessary to fully comply with approval requirements and good installation practices.



**WARNING** - Installation and Maintenance must be carried out by suitably skilled and competent personnel only.

# Table of Contents

	Page
<b>Warranty Statement</b>	<b>i</b>
<b>Warnings</b>	<b>i</b>
<b>Table of Contents</b>	<b>ii</b>
<b>1.0 Introduction</b>	<b>1</b>
1.1 General Description .....	1
<b>2.0 Specifications</b>	<b>2</b>
2.1 Approvals .....	2
2.2 Functional.....	2
2.3 Mechanical .....	3
2.4 Environmental .....	3
2.5 Electrical.....	3
2.6 Factory default settings.....	4
2.7 Sensor Material and Specifications when connected to S4100C .....	4
2.8 Outline Drawing.....	5
<b>3.0 Installation</b>	<b>5</b>
3.1 On Receipt of your Equipment.....	6
3.2 Smart Transmitter location Guidelines.....	6
3.3 Sensor Poisons .....	7
3.4 Interconnecting cable Guidelines.....	8
3.5 Installation of Sensor .....	8
3.6 Installation Instructions .....	9
3.6.1 Smart Transmitter Cable Termination.....	9
3.6.2 Cable Termination in Safe Area.....	9
3.6.3 Cable Termination Drawing.....	10
3.7 Interconnection Details .....	12
3.8 Power up Routine (see also Section 4.5 and 4.6) .....	12
3.9 If the instrument indicates differently from the above, refer to Section 6, Trouble Shooting. Stopping Plug Installation .....	12
<b>4.0 Operating Instructions</b> .....	<b>15</b>
4.1 Menu Operation and Display Codes .....	15
4.2 Tables .....	17
4.3 Calibration .....	19
4.4 New Sensor Calibration .....	20
4.5 Calibration Check.....	21
4.6 Power up Routine.....	21
4.7 Special Power up Routine.....	22
<b>5.0 Maintenance</b>	<b>23</b>

	5.1Maintenance.....	23
	5.2Storage.....	23
<b>6.0</b>	<b>Trouble Shooting .....</b>	<b>24</b>
	6.1Fault codes and Remedies .....	24
	6.2Alarms .....	25
	6.3Modbus RTU Serial Interface problems.....	25
<b>7.0</b>	<b>Ancillary Equipment .....</b>	<b>26</b>
	7.1Dust Guard Assembly (P/N 10110).....	26
	7.2Sintered Stainless Steel Dust Guard (P/N 1800822-1) .....	26
	7.3Splash Guard (P/N 10395-1) .....	26
	7.4Sensor Flow Chamber (P/N 10066).....	26
	7.5Duct Mounting Plate (P/N 10041 Dash-1 or -2) .....	27
	7.6Portable Purge Calibrator – Model 1400150 .....	27
	7.7Remote Test Gas Applicator – TGA-1 .....	29
	7.8Volatile Liquids and Solvents .....	30
<b>8.0</b>	<b>Modbus RTU Serial Interface .....</b>	<b>31</b>
	8.1General .....	31
	8.2Modbus Message Characteristics .....	31
	8.3Modbus Exception Codes .....	31
	8.4Modbus Read/Write - Commands.....	32
	8.5Modbus Register Configuration .....	33
	8.5.1 Register 3 .....	33
	8.5.2 Register 7 .....	34
	8.5.3 Register 9 .....	34
	8.5.4 Register 10 .....	34
<b>9.0</b>	<b>Appendix A 35</b>	
	9.1Maximum Sensor Cable Length.....	35
	9.2Maximum Smart Transmitter Cable Length .....	35
	<b>Customer Satisfaction Questionnaire.....</b>	<b>37</b>

# 1.0 Introduction

## 1.1 General Description

The General Monitors Model S4100C Smart Transmitter is a highly reliable, self contained, microprocessor controlled, Hydrocarbon gas monitor with integral 3-digit readout. The Transmitter is connected to the user's indicating and shut-down equipment by means of a screened and armoured cable.

The S4100C is designed to measure and display concentrations of combustible gases in the range of: 0-100% Lower Explosive Level (LEL), but will continue to display concentrations up to 120% LEL.

No user adjustments are required. The instrument will record the number of successful calibrations, compute the sensor output as a % of the new sensor reference output during calibration and store in non-volatile memory, along with calibration and setup parameters.

The entire electronics module is fully encapsulated in compliance with the relevant standards.

The Smart Transmitter's user interface is menu driven. In addition the instrument may be addressed via the Dual Modbus RTU serial interface.

The accuracy of the Smart Transmitter depends upon routine re-calibration which should be carried out at least every 90 days. This procedure is extremely simple and may be carried out by one person aided by prompts from the digital display. Calibration may be completed in less than 2 minutes. All calibration parameters are tested by advanced software routines before being accepted. Any errors detected will be shown on the digital display by means of an appropriate fault code.

General Monitors is recognised as a leader in the field of gas detection and a team of experts is always available to provide advice or service as required.



## 2.0 Specifications

### 2.1 Approvals

Hazardous Area Standards	EN 60079-0, EN 60079-7, EN 60079-18, EN 60079-29-1
Code of Protection	Ex emd IIC T5 Gb (Tamb -40°C +55°C) Ex emd IIC T4 Gb (Tamb -40°C +70°C) Cable insulation rated to at least 110°C
Application:	Combustible Gas Monitor

### 2.2 Functional

Measuring Range:	0-100% LEL
Measuring Resolution	1% LEL
Over-range Indication:	Display flashes for readings greater than 99% LEL, but continues to display gas concentration up to 120% LEL.
Calibration Level:	User selectable 25% - 90% LEL in 1% LEL increments
A1 Trip Level:	User selectable 10% - 60% LEL in 1% LEL increments
A1 Open Collector Output	User selectable Energised/De-energised and Latching/Non-latching
A2 Trip Level:	User Selectable 10% - 60% LEL in 1% LEL increments
A2 Open Collector Output	User selectable Energised/De-energised and Latching/Non-latching
Fault Open Collector Output	Normally Energised
Analogue Output during Calibration	User selectable 0.0 mA, 1.5 mA and 2.0 mA
Modbus Baud Rate	User selectable 2400, 4800, 9600 and 19200 Baud
Modbus Format	User selectable 1/2 stopbits, odd/even/no parity, 8 databits
Modbus Node Address	User selectable 1 – 255; Address 0 is recognised as broadcast mode
Repeatability, Short Term:	±5% LEL over 1 hour
Repeatability, Long Term:	±10% LEL over 3 months
Accuracy (Linearity)	±5% LEL
Temperature Variation	±10% LEL over Temperature Range (-50°C to +70°C)
Pressure Variation:	±10% LEL (950 mBar – 1100 mBar)
Humidity Variation:	±10% LEL (20% RH – 90% RH)
Power up Variation:	< 3% LEL after 5 minutes
Response Time (input step)	T50 < 10 seconds T90 < 23 seconds

## 2.3 Mechanical

Height excl. Sensor:	150mm (6")
Height incl. Sensor:	200mm (8")
Width:	150mm (6")
Depth:	95mm (3.75")
Weight including Sensor:	2.5kg (5.5lbs)
Mounting Holes:	4 x 7 mm (0.28") dia holes
Termination:	Ex e rated Terminal Block

## 2.4 Environmental

Operating temperature range (continuous) min/max	- 40°C to + 70°C
Storage temperature range min/max	- 50°C to + 85°C
Relative humidity min/max:	5% to 100%, non-condensing
Operating Altitude max:	8000 ft
Non-operating Altitude max:	16000 ft
EMI/RFI Susceptibility;	Meets EN 50270 EN55011: ENV50204 EN 61000-4-2: EN 61000-4-4: EN 61000-4-6 EN 61000-4-3: EN 61000-4-5: EN 61000-4-8
IP Rating:	IP66/67

## 2.5 Electrical

Supply voltage min/max:	10VDC/35VDC operating
Supply voltage abs min/max:	8VDC/40 VDC
Supply voltage ripple & noise max.	1Vpp
Supply current consumption, including sensor typ/max:	250mA/310mA @ 24 VDC 500mA/620mA @ 12 VDC
Supply fuse rating:     18VDC – 35VDC operation 10VDC – 35VDC operation	500mA Chart "T" PC ≥ 1500A 1A Chart "T" PC ≥ 1500A
Supply voltage low detection threshold min/max:	9.20VDC/10.32 VDC
Sensor Bias Current (Rsensor + Rcable = 6ohms –30ohms):	300mA ± 10mA
Sensor Bias Current (Rsensor + Rcable = zero ohms) max:	410mA
Sensor Cable Resistance per conductor max:	5 ohms
Analogue output Current Range:	0 – 22.0mA
Analogue Signal Startup	4mA ± 0.2mA
Analogue Signal 0-100% LEL	4-20mA
Analogue Output Current abs max:	22.1mA
Analogue Output Current Ripple and Noise max.	20uApp



Analogue output termination resistance min/max: (including total cable resistance)	0 – 750 ohms
Analogue output open-circuit detection current range min/max:	1.0mA – 22.0mA
Analogue output fuse rating:	63mA Char “F” PC ≥ 1500A
Remote calibration input Isink max	2.7mA
Remote calibration input Vin max:	24VDC
Open collector output Isink max Note: Inductive loads require an external clamp diode	100mA
Open collector output Vin max:	35VDC
Open collector output Vdrop-out @ 100mA max:	1VDC

## 2.6 Factory default settings

Calibration level:	50% LEL
A1 Trip Level	20% LEL
A1 Open Collector Output:	De-energised and non-latching
A2 Trip Level:	50% LEL
A2 Open Collector Output	De-energised and non-latching
Analogue output during calibration	1.5mA
Modbus Baud rate:	19200 Baud
Modbus Format:	1 stopbit, no parity, 8 data bits
Modbus Node address;	1

## 2.7 Sensor Material and Specifications when connected to S4100C

General Monitors Sensors (11159-X) are constructed from 316 Stainless Steel. The temperature and classification becomes

Ex emd IIC T5 Gb (Tamb -40°C to +55°C)

Ex emd IIC T4 Gb (Tamb -40°C to +70°C) when the sensors are fitted to the S4100C units only.

**2.8 Outline Drawing**

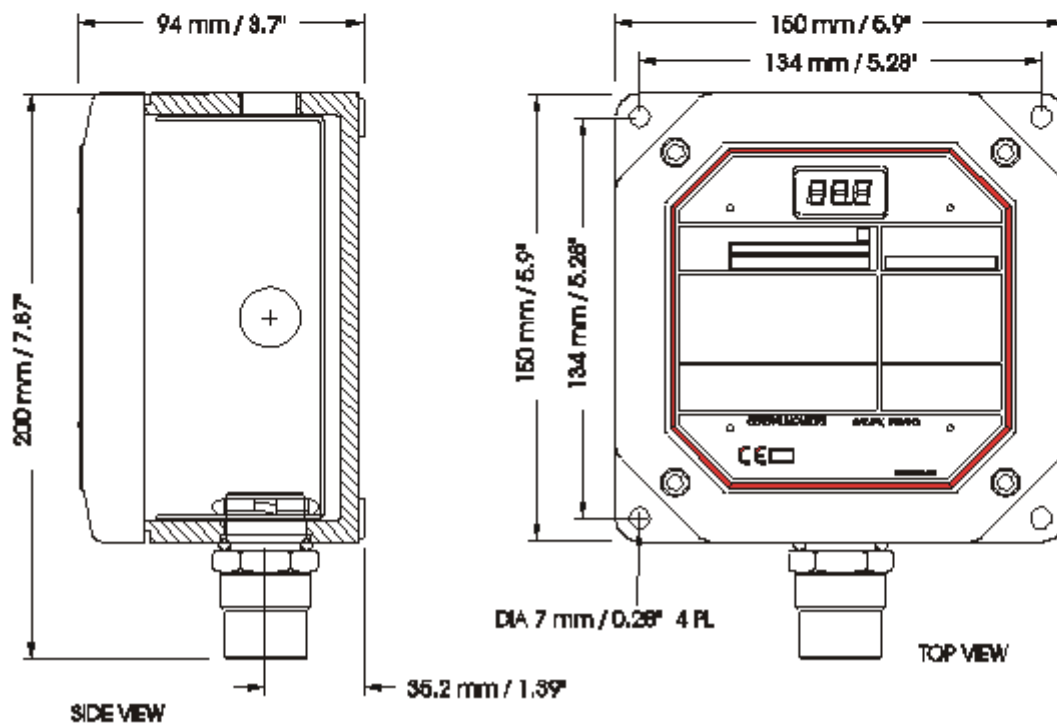
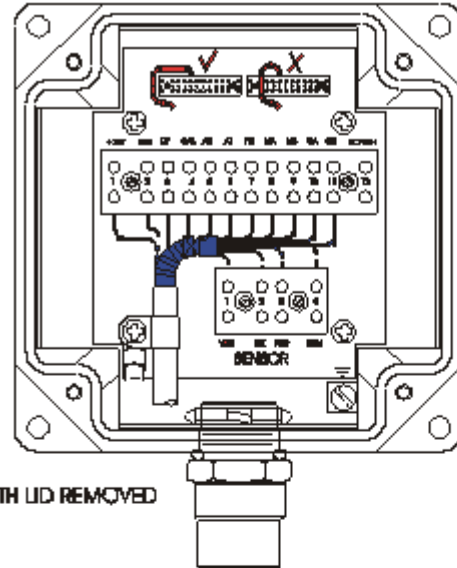

## 3.0 Installation



**WARNING** - Installation and Maintenance must be carried out by suitably skilled and competent personnel only.

### 3.1 On Receipt of your Equipment

All instruments shipped by General Monitors are pre-packed in stout containers and enclosed in a shock absorbing filling which affords a considerable degree of protection against physical damage. The contents should be carefully removed and checked against the enclosed packing slip.

All discrepancies between the contents and the packing slip must be reported to General Monitors within 10 days of receipt of equipment. General Monitors cannot be held responsible for shortages not reported within this period.

Damage to the contents of a shipment should be brought to the attention of the carrier immediately and a claim filed.

All subsequent correspondence with General Monitors must specify the equipment part numbers and serial numbers.

### 3.2 Smart Transmitter location Guidelines

The following guidelines should be observed with regard to the location in which to install a Smart Transmitter. Note that the vapour from a flammable liquid should, in general, be treated in the same manner as a gas, but refer to the additional precautions listed below:

- Consider how the leaking gas will disperse. Locate the Smart Transmitter where prevailing air currents are likely to contain the maximum amount of leaking gas, but sufficiently distant from minor leak sources so as to avoid spurious alarms.
- Consider the emission temperature and specific gravity of the gas to be detected. The Smart Transmitter should be located close to ground level (but out of the splash zone) for gases which are heavier than air, and close to the ceiling or roof for gases which are lighter than air. Liquids of low volatility may require the Smart Transmitter to be sited in the immediate vicinity of the potential leaking points.
- Site the Smart Transmitter so as to facilitate routine re-calibration; refer to the Ancillary Equipment Section of the manual for details. Ensure that the mounting allows for the replacement of a faulty sensor and that access to any accessories is not restricted. Check that the calibration instructions and display will be visible under all normal weather conditions whenever required. A combination of rain and sun guard is recommended for outdoor locations because it protects the Smart Transmitter against the heat of direct sunlight and the adverse effects of rain-borne grime whilst simultaneously improving display visibility under sunny conditions.

- Observe the ambient temperature limitations quoted in the specification. If a sampling preconditioning system is employed, take steps to ensure that vapours will not condense in the associated pipework.
- The mounting should be as free from shock and vibration as possible. Avoid mounting Smart Transmitters directly on structures or process equipment prone to high levels of vibration or shock.
- Select sensor accessories so as to protect the sensor against high wind velocities, rain, dust, hosing down and any other anticipated environmental hazards.
- Avoid locations where the Smart Transmitter will be subjected to strong electromagnetic interference (greater than 10V/m field strength) such as found in proximity to radio transmitters, welders, switched mode power supplies, inverters, battery chargers, ignition systems, generators, switch-gear, arc lights and other high frequency or high power switching process equipment. Walkie-talkie radios should not be operated at a distance less than 0.75m from the Smart Transmitter.

### 3.3 Sensor Poisons

HC Sensors may be adversely affected by prolonged exposure to certain atmospheres. These in the main are chemical poisons, although other substances such as silicones coat the sensor beads, thus rendering them insensitive to combustible gases.

Such loss of sensitivity may be gradual, if the poisons are present in very low concentrations, or rapid in the event of large concentrations of poisons being present.

The most important poisons are:

Halides: Compounds containing fluorine, chlorine, bromine and iodine  
Glycols  
Sulphur compounds  
Compounds that polymerise on the beads  
Heavy Metals: e.g. Tetraethyl lead

Silicones contained in grease or aerosols are the most common coating agents that are not true sensor poisons, but reduce sensor response.

Other materials that have a deleterious effect on HC Sensors include mineral acid vapours and caustic vapours that attack the sensor physically.

The presence of such poisons and damaging vapours does not imply that the General Monitors sensor may not be used in these locations. A careful analysis of ambient air conditions should be undertaken and the customer should be aware that sensor calibration might need to be repeated at shorter intervals.

### 3.4 Interconnecting cable Guidelines

- The Smart Transmitter requires an interconnecting cable with an overall screen (shield) and armour. Cables to BS5308 Part 2, Type 2 or equivalent are suitable.
- Interconnecting cables should be segregated from power and other “noisy” cables. Avoid proximity to cables associated with radio transmitters, welders, switched mode power supplies, inverters, battery chargers, ignition systems, generators, switch gear, arc lights and other high frequency or high power switching process equipment. In general, maintain a separation of at least 1m between instrument and other cables. Greater separation is required where long parallel cable runs are unavoidable. Avoid running instrument cable trenches close to lightning conductors earthing pits.
- Complete all cable insulation tests **before** connecting the cable at either end.
- General Monitors do not recommend the use of cable shoes or crimps on any junction box or housing wiring terminals. Poor crimping can cause bad connection when unit experiences temperature variations. We therefore recommend good practice is to just terminate cable or sensor wires as is, especially in remote sensor applications.

### 3.5 Installation of Sensor

General Monitors sensors are machined to a  $\frac{3}{4}$  NPT thread for fixing into the junction box, through a suitably machined entry. Each sensor requires a suitable O’Ring and Lock Nut to ensure correct assembly. To assemble the sensor into the junction box the wires should be placed through the O’Ring, over the  $\frac{3}{4}$  NPT thread until it rests at the end of the machined thread. The sensor is then placed through the entry of the junction box and held in place by fitting the  $\frac{3}{4}$  NPT Lock Nut. The sensor should be tightened sufficiently to ensure a good seal, but not over tightened to damage the O’Ring. The colour coded wires should then be connected into the corresponding locations of the connector which is installed and labelled in the junction box. Care should be taken not to tighten the connection on the insulation of the wires.

## 3.6 Installation Instructions

### 3.6.1 Smart Transmitter Cable Termination

- The Smart Transmitter should be installed in accordance with the certification documents and the relevant regulations of the country concerned.
- Ensure that the gas sensor, if used, points downwards so as to protect it from rain and the accumulation of deposits.
- Ensure that approved Exe cable glands are used and installed according to the manufacturer's instructions.
- The cable glands must be electrically connected to the continuity plate by means of a suitable nut. The cable armour must be terminated in the gland to ensure a positive electrical connection.
- The cable screens (drain wires) must all be terminated on the isolated terminal in the transmitter housing (and sensor junction box if the sensor is mounted remotely). The cable screens must not be connected electrically to the electronic circuitry of the Smart Transmitter or the sensor.
- Connect an external earth stud in accordance with local practice if required.
- Ensure no wires cross over the top of the connector blocks as they may become trapped between the blocks and the electronics module when the lid is fitted.
- When fitting the lid, ensure the fly-lead and earth strap from the electronics module fit freely into the box. Press the lid home and verify it fits snugly against the box, before tightening the screws.
- Ensure there is 1mm spacing between insulation of wire and end connector block. Ensure that insulation is not crimped.

### 3.6.2 Cable Termination in Safe Area

- The cable armour must be connected to Safety Earth.
- The cable screens (drain wire) and power supply return (OV) must be connected to Instrument Earth.
- The power supply or power distribution system employed should meet the requirements of EN5008 I- 1/2 and EN60101-1.
- **Power supply or GM Trip Amplifier Power and analogue output must be fused in accordance with the Smart Transmitter specification.**

### 3.6.3 Cable Termination Drawing

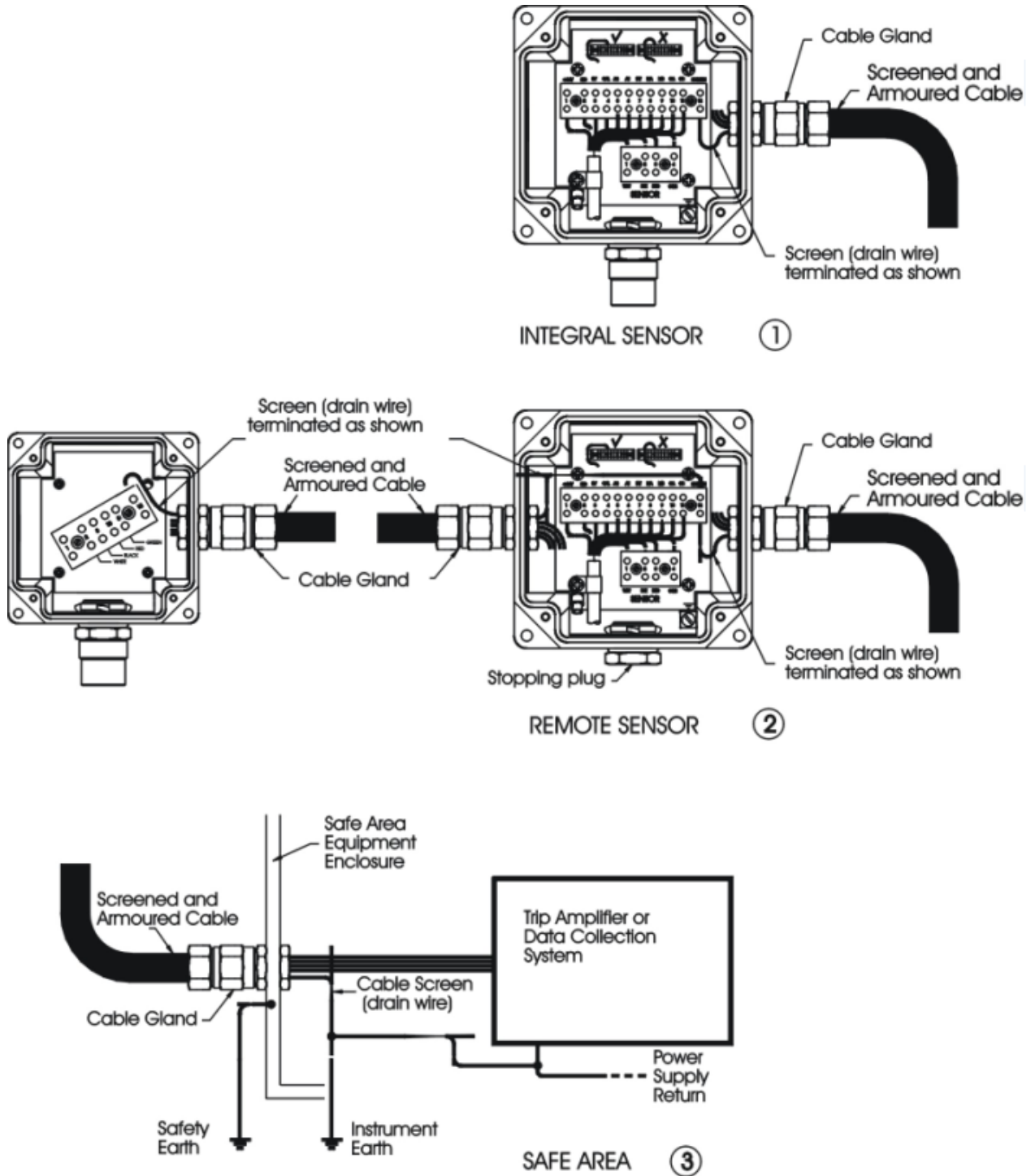

**NOTE:**  
Cable Armour connected to  
Safety Earth via Gland or otherwise

The electrical rating for all open collector outputs is 100mA @ 35VDC.

The diagram below illustrates some typical open collector external circuits.

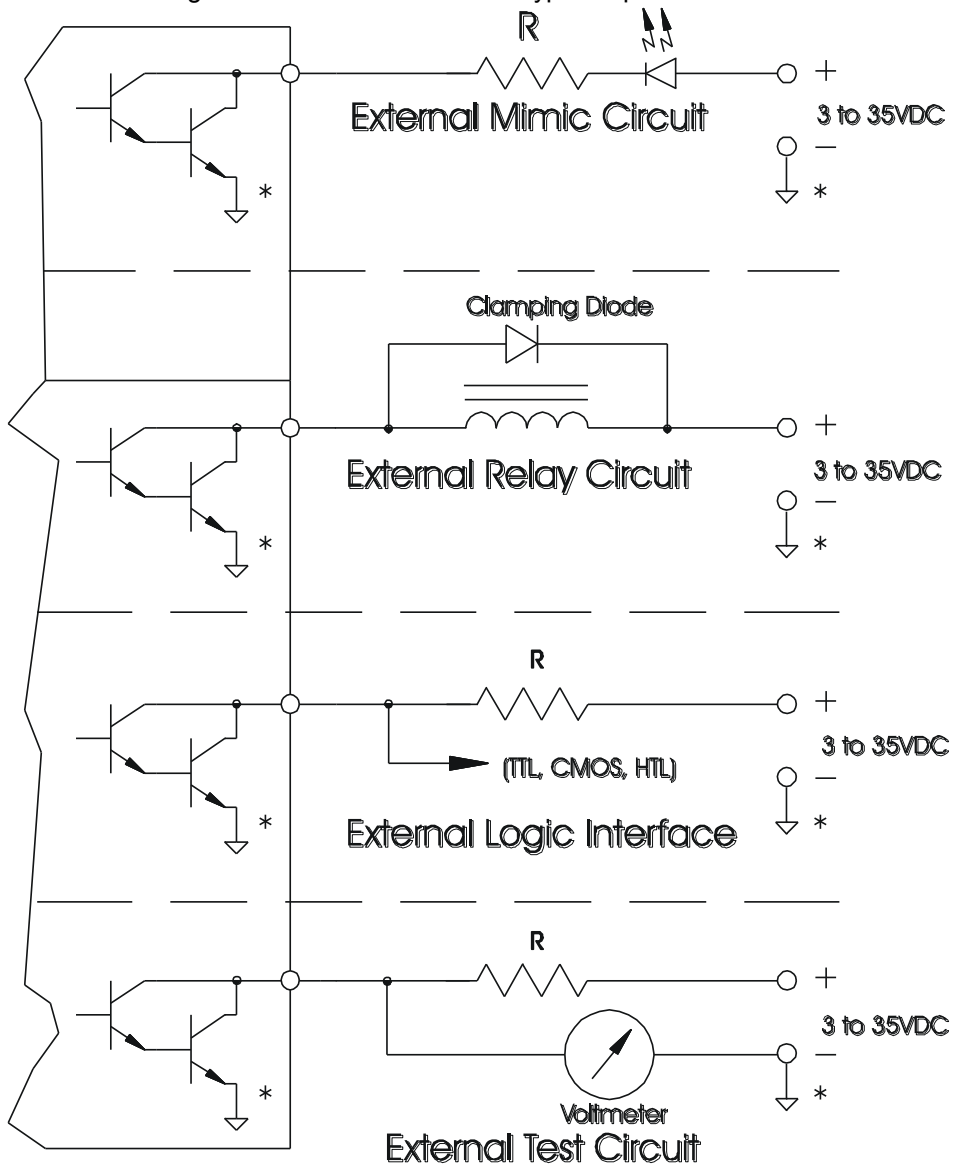

\* Note: All system commons (  ) must be tied together.



### 3.7 Interconnection Details

Signal Name	12-Way Terminal	Function	If not used	Module Fly lead colour
+ 24VDC	1	Power Supply		brown
SIG	2	Analogue output	connect to OV	yellow
OV	3	Power Supply Return		blue
CAL	4	Remote calibration input (Note)	leave unconnected*	grey
A2	5	Alarm 2 open collector output	leave unconnected*	orange
A1	6	Alarm 1 open collector output	leave unconnected*	violet
FLT	7	Fault open collector output	leave unconnected*	green/black
MA	8	Modbus 1 serial interface line A	leave unconnected*	red/black
MB	9	Modbus 1 serial interface line B	leave unconnected*	red/green
GA	10	Modbus 2 serial interface line A	leave unconnected*	red/brown
GB	11	Modbus 2 serial interface line B	leave unconnected*	red/blue
SCREEN	12	Terminate all cable screens (drain wires) at this connection		NA

Signal Name	4-Way Terminal	Function	Module Fly lead colour
WHT	1	Sensor active bead	white
BLK	2	Sensor passive bead	black
RED	3	Sensor common	red
GRN	4	NA	NA

\* Ensure conductor ends have been cut back so that bare conductors do not cause shorts.

**NOTE:** If remote calibration is required, connect the Remote Calibration Input to Power Supply Return via a momentary action-NO-switch in the Safe Area. The switch should be rated 5V, 5mA or better.

**NOTE:** For Smart Transmitter and Sensor Interconnection Cable details consult Appendix A.

### 3.8 Power up Routine (see also Section 4.5 and 4.6)

When all wiring has been completed and checked, the instrument may be powered up.

Immediately following power-up, the instrument will carry out "Display Test", then blank the display for 1 second, display "Software Revision" and then display "Power up in progress", followed by normal operation. The analogue output will be at 4.0mA and the Fault open collector output energised.

The display should read "0" if no gas is present at the sensor.

### 3.9 If the instrument indicates differently from the above, refer to Section 6, Trouble Shooting. Stopping Plug Installation

**NOTE:** The stopping plug, 311001-1, is fitted at the factory, the following instruction will only be necessary if the stopping plug has been removed from its current location to another entry of this product.

- Screw Earth/Stopping Plug (P/N 311001-1) into Top Entry of S4100x Housing.
- Fully tighten using a suitable hand wrench.

- Do not over tighten such that the O'Ring is damaged
- Screw Continuity Hex Nut (P/N 928-814) on the inside of the S4100x Housing to the Earth/Stopping Plug (P/N 311001-1).
- Tighten to insure it is secure and making good contact with internal continuity plate.

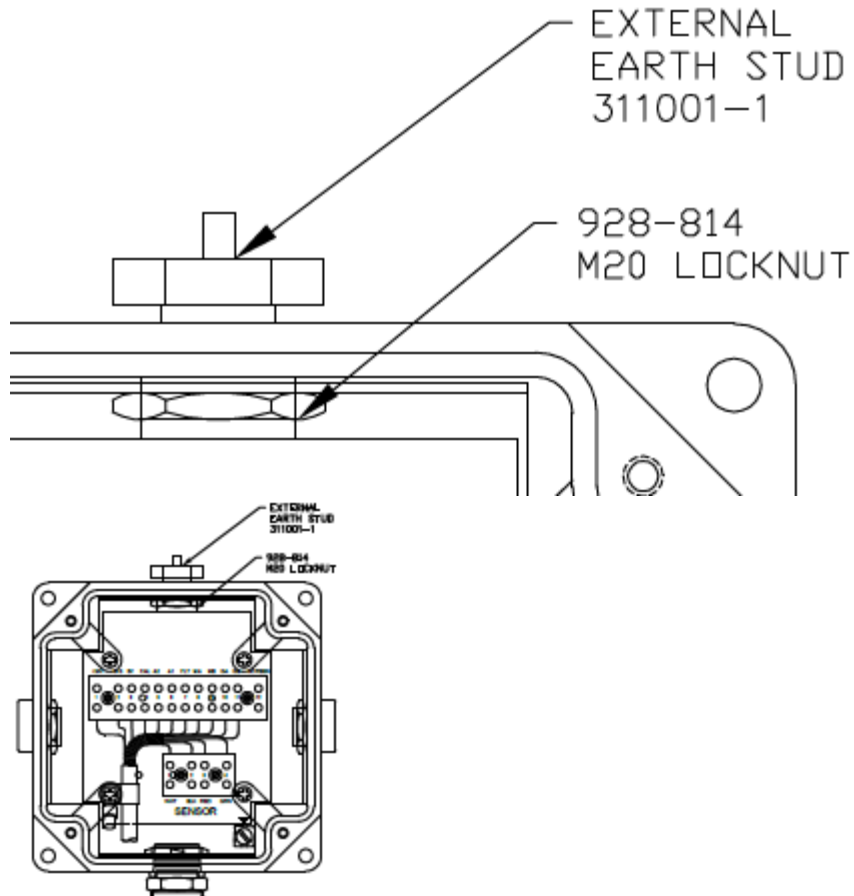

- If removing the Earth/Stopping Plug (P/N 311001-1), unscrew Continuity Hex Nut (P/N 928-814) on the inside of the S4100x Housing from the Earth/Stopping Plug.
- Unscrew the Earth/Stopping Plug (P/N 311001-1) from the Top Entry of S4100x Housing.



## 4.0 Operating Instructions



**WARNING** – Installation and Maintenance must be carried out by suitably skilled and competent personnel only.

### 4.1 Menu Operation and Display Codes

Note: See Table 1 and Table 2 for Display Codes

Menu operation starts at Level 1. To enter the menu, the magnet is applied to the General Monitors Logo on the Nameplate and held in place. The instrument will display “- - -” indicating magnet present. After 5 seconds delay the instrument will start scrolling through Table 1, Level 1 at the rate of 1 step per 2 seconds, the magnet may now be removed. In the presence of (latched) Alarms, the delay time will increase to 90 seconds. The scrolling will continue until a selection is made by briefly applying the magnet. The display will rapid-flash the selection for one second to acknowledge. The operation will then move to the next level corresponding to that selection, which can be scrolled in a similar fashion, etc.

At all menu levels, the instrument will start “10 second menu timeout”, 30 seconds after the last selection was made, allowing the user to re-enter the menu while the analogue output is still at cal level (0.0, 1.5 or 2.0mA). Once “10 second menu timeout” has expired, menu data is written to EEPROM, following which the instrument returns to normal operation.

Calibration and Check Calibration mode will be terminated upon completion of the corresponding calibration or calibration check procedure. The unit expects to “see” calibration gas within 6 minutes following selection and will display the appropriate fault code if no gas has been applied and exit the menu. Similar action occurs if the calibration gas supply is interrupted during “Calibration in progress” or if the calibration gas is not removed within 6 minutes following “Calibration completed.”

While in Check Calibration mode, Calibration mode may be activated by entering the menu as normal.

When A1 alarm trip level, A2 alarm trip level or Calibration is selected, the current value is shown on the display. The most significant digit will scroll and the desired value is acknowledged by briefly applying the magnet, following which the next lower significant digit will scroll and is acknowledged in similar fashion. The display will rapid-flash each selection for one second to acknowledge. If the current value is acceptable, two or three subsequent “acknowledge” commands, (one for each digit) will allow the user to continue.

Setting A1 alarm trip level higher than the current A2 alarm trip level causes the A2 alarm trip level to be set to the same level as A1 alarm trip level and following acknowledge of A1 alarm trip level the menu automatically jumps to “A2 alarm set up” to alert the user and allow re-adjustment of A2 alarm trip level. Similar action occurs if A2 alarm trip level is set lower than the current A1 alarm trip level.

Change of Calibration level causes the instrument to enter Calibration mode immediately, alleviating the necessity of a password option.

Faults and Alarm status and LEL level determine which Level 1 menu selections are available. **Any Fault except F08 inhibits menu operation.**

Menu Selection Availability:

<b>Faults?</b>	<b>Alarms?</b>	<b>Latched Alarms?</b>	<b>LEL&lt;10%</b>	<b>Level 1 menu selections available</b>	<b>Menu entry delay</b>
No	No	No	Yes	ACA, CCA, ASU, CSU & ncl	5 sec
No	No	No	No	ACA, ASU, CSU & ncl	5 sec
No	No	Yes	Yes	ACA, & CCA	90 sec
No	No	Yes	No	ACA & ncl	90 sec
No	Yes	No	NA	ACA & ncl	90 sec
No	Yes	Yes	NA	ACA & ncl	90 sec
Yes	NA	NA	NA	None	NA

## 4.2 Tables

TABLE 1 – MENU DISPLAY CODES							
Level 1		Level 2		Level 3		Level 4	
<i>ACA</i>	Activate calibration mode	<i>AC</i>	Activate calibration, Apply calibration gas				
		<i>CP</i>	Calibration in progress				
		<i>CC</i>	Calibration completed, Remove calibration gas				
<i>CCA</i>	Check calibration mode	<i>ACA</i>	Activate calibration mode				
<i>ASU</i>	Activate setup mode	<i>A1</i>	A1 alarm setup	<i>En</i>	Open collector output normally energized		
				<i>dE</i>	Open collector output normally de-energized		
				<i>LA</i>	Open collector output latching		
				<i>nL</i>	Open collector output non-latching		
				<i>tP</i>	Triplelevel setup	<i>88</i>	Triplelevel adjustable 10% LEL to 60% LEL
				<i>A2</i>	A2 alarm setup		
				<i>rn</i>	Return to level 2		
		<i>A2</i>	A2 alarm setup	<i>En</i>	Open collector output normally energized		
				<i>dE</i>	Open collector output normally de-energized		
				<i>LA</i>	Open collector output latching		
				<i>nL</i>	Open collector output non-latching		
				<i>tP</i>	Triplelevel setup	<i>88</i>	Triplelevel adjustable 10% LEL to 60% LEL
				<i>--</i>	Analogue output setup		
				<i>rn</i>	Return to level 2		
		<i>--</i>	Analogue output setup	<i>00</i>	Analogue output 0mA during calibration		
				<i>15</i>	Analogue output 1.5mA during calibration		
				<i>20</i>	Analogue output 2.0mA during calibration		
				<i>--</i>	Calibration level setup		
				<i>rn</i>	Return to level 2		
		<i>--</i>	Calibration level setup	<i>88</i>	Cal. Level adjustable 25% LEL to 90% LEL		
				<i>A1</i>	A1 alarm setup		
				<i>rn</i>	Return to level 2		
		<i>rn</i>	Return to level 1				

**TABLE 1 – MENU DISPLAY CODES**

Level 1		Level 2		Level 3		Level 4
<b>CSU</b>	Check setup mode	- 00	A1 open collector output norm. (de)-energized			
		- 00	A1 open collector output (non)-latching			
		- 00	A1 alarm triplelevel % LEL			
		= 00	A2 open collector output norm. (de)-energized			
		= 00	A2 open collector output (non)-latching			
		= 00	A2 alarm triplelevel % LEL			
		c 00	Analogue output current during calibration in mA			
		L 00	Calibration level % LEL			
		000	Response @ cal in % of mV reference			
		000	Response reference in mV			
		000	Nr. Of successful calibrations			
		000	Modbus port 1 & 2 node address			
		r t n	Return to level 1			
<b>n c l</b>	New sensor calibration	<b>n c l</b>	New sensor calibration	<b>AC</b>	Activate calibration, Apply calibration gas	Note: This operation sets nr. of calibrations to 1 and redefines sensor mV reference when successful
				<b>CP</b>	Calibration in progress	
				<b>CC</b>	Calibration completed, Remove calibration gas	
		<b>r t n</b>	Return to level 1			
<b>t e r</b>	Terminate menu					

**t e r** Slow Flash (2/sec)  
 "10 sec Menu Timeout in progress". This timeout starts 30 sec after the last menu selection was made.  
 Apply magnet to re-enter at Level 1. The analogue output remains at calibration level in this mode.  
 If magnet not applied, the instrument will write menu parameters to EEPROM, exit menu and revert to normal operation following timeout.

**TABLE 2 – DISPLAY CODES**

<b>8.8.8.</b>	Display Test (1 sec)
<b>r 00</b>	Software Revision (1 sec)
<b>SU</b>	Power up in progress (58 sec)
<b>- 00</b>	Gas measurement with A1 alarm condition present, or latched A1 alarm pending
<b>= 00</b>	Gas measurement with A2 alarm condition present, or latched A2 alarm pending
<b>000</b>	Slow Flash (2/sec) "Overrange" if display > 99% LEL or "Check Calibration Mode active"
<b>000</b>	Rapid Flash (8/sec) "Acknowledgement of menu selection" or "Magnet present" during alarm or fault indication
<b>EE</b>	EEPROM write activity
<b>F 00</b>	Fault Codes
<b>- - -</b>	"Magnet present"

## 4.3 Calibration

Calibration may be carried out as follows:

- Ensure that the instrument has stabilised for at least 1 hour and that there is no combustible gas present at the sensor. If the background levels of gas are suspected, their presence may be confirmed by capping the sensor and observing a fault in indicated gas concentration as the sensor oxidises the entrapped gas. A true zero reading will be obtained when the reading stabilises at the lower value.
- Place the magnet on the General Monitors Logo on the Nameplate. The instrument will display “ - - - ” for 5 seconds and then enter the menu routine. Remove the magnet. Select “ACA” by briefly re-applying the magnet when the display scrolls around. The instrument will acknowledge the selection by rapid flashing “ACA” for 1 second and continue to display “ACA” for another 7 seconds while it takes the zero gas reading. The instrument will then display “AC”.

**NOTE:** Calibration mode may be terminated at this point by briefly re-applying the magnet.

- Use General Monitors Portable Purge with flow rate of 300-400ml/min, or Calibration Chamber to apply gas at the required concentration level. When the instrument detects the gas it will display “CP”.
- When the instrument displays “CC”, normally within 2 minutes, remove the calibration gas.
- As the remaining gas in the sensor disperses, the instrument will exit Calibration mode and return to normal operation. The display should read “0”.

If the above procedure is unsuccessful, refer to the Trouble Shooting section in this manual.



## 4.4 New Sensor Calibration

New sensor calibration may be carried out as follows:

- Ensure that the instrument has stabilised for at least 1 hour and that there is no combustible gas present at the sensor. If the background levels of gas are suspected, their presence may be confirmed by capping the sensor and observing a fault in indicated gas concentration as the sensor oxidises the entrapped gas. A true zero reading will be obtained when the reading stabilises at the lower value.
- Place the magnet on the General Monitors Logo on the Nameplate. The instrument will display “ - - ” for 5 seconds and then enter the menu routine. Remove the magnet. Select “ncl” by briefly re-applying the magnet when the display scrolls around. The instrument will acknowledge the selection by rapid flashing “ncl” for 1 second. Re-confirm by briefly re-applying the magnet when the display shows “ncl” or return to the previous level by briefly applying the magnet when the display shows “rtn”. The unit will continue to display “ncl” for another 7 seconds while it takes the zero gas reading. The instrument will then display “AC”.

**NOTE:** Calibration mode may be terminated at this point by briefly re-applying the magnet.

- Use General Monitors Portable Purge with flow rate of 300-400ml/min., or Calibration Chamber to apply gas at the required concentration level. When the instrument detects the gas it will display “CP”.
- When the instrument displays “CC”, normally within 2 minutes, remove the calibration gas.
- As the remaining gas in the sensor disperses, the instrument will exit Calibration mode and return to normal operation .The display should read “0”.
- This calibration procedure resets “number of successful calibrations” to 1 and re-defines the “sensor response reference” parameter from which all subsequent “sensor response during calibration” percentages are computed.

When cross-calibrating, verify a “new sensor calibration” was carried out with the reference gas, as this may be different from the gas used during factory calibration, leading to incorrect “sensor response during calibration” percentages.

If the above procedure is unsuccessful, refer to the Trouble Shooting section in this manual.

## 4.5 Calibration Check

- Place the magnet on the General Monitors Logo on the Nameplate. The instrument will display “ - - -” for 5 seconds and then enter the menu routine. Remove the magnet. Select “CCA” by briefly reapplying the magnet when the display scrolls around. The instrument will acknowledge the selection by rapid flashing “CCA” for 1 second and continue to display “CCA” for another 7 seconds while it takes a zero gas reading. The display will then slow-flash the gas concentration. The analogue output will remain at calibration level.

**NOTE:** The sensor should be exposed to clean air conditions for at least 2 minutes prior to entering Calibration check mode, such that the zero reading taken by the instrument is valid.

**NOTE:** Calibration Check mode may be terminated at this point by briefly re-applying the magnet.

- Use General Monitors Portable Purge with flow rate 300-400ml/min, or Calibration Chamber to apply gas at the required concentration level. The instrument will measure and display gas concentrations. Observe that the gas reading settles at the required level. Should the final reading fall outside the required limits, a full calibration is required. If so proceed as follows:
- Place the magnet on the General Monitors Logo on the Nameplate. The instrument will display “ - - -” for 5 seconds and then show “ACA”. Select by briefly re-applying the magnet. The instrument will acknowledge the selection by rapid flashing “ACA” for 1 second. The instrument will then display “AC” followed shortly by “CP”. Continue as described in Calibration.
- While in Calibration Check the display will continue to slow-flash the reading and the analogue output remains at calibration level until the gas has been removed and the concentration at the sensor has dropped below 3.5% LEL, when the instrument will exit Calibration Check mode and return to normal operation.

If the above procedure is unsuccessful, refer to the Trouble Shooting section in this manual.

## 4.6 Power up Routine

Immediately following power-up, the instrument will carry out “Display Test”, then blank the display for 1 second, display “Software Revision” and then display “Power up in progress” followed by normal operation. The analogue output will be at 4.0mA and the Fault open collector output energised.

## 4.7 Special Power up Routine

If the instrument is powered up with the magnet present it will display “EEPROM write activity” for 1 second, followed by “Power up in progress” as above. The magnet present will cause the Modbus Parameters to be reset to factory default. The magnet may be removed immediately.

If the instrument is powered up with the magnet Present AND the Remote Calibration input active it will display “EEPROM write activity” for 1 second, followed by “Power up in progress” as above. This condition will cause the Power-up EEPROM CRC check to be bypassed and the Modbus Parameters, all calibration and menu parameters to be reset to factory default. On exit from Power up, the instrument will enter Calibration mode. This feature is available to allow recovery in the field, should the EEPROM contents have been corrupted due to a power failure coinciding with an EEPROM write cycle. The magnet may be removed and the Remote Calibration input deactivated immediately.

## 5.0 Maintenance



**WARNING** - Installation and Maintenance must be carried out by suitably skilled and competent personnel only.

### 5.1 Maintenance

Once correctly installed, systems require very little maintenance other than Routine Re-calibration (see section 4) and periodic inspection.

Sensors exposed to the elements may require a little grease on the accessory mounting threads. The grease must be free from silicones (Refer to Sensor Poisons) and have a high melting point. Alternatively P.T.F.E. tape may be used.

The removal of particulate matter from sensor accessories may be facilitated by the use of an appropriate halogen-free solvent. The accessories should be thoroughly dried, with compressed air if necessary, before refitting to the sensor body.

General Monitors strongly recommends that the complete system, including all alarm circuitry be tested at least annually and that the following checks be carried out:

- All Smart Transmitter assemblies for suitability of mounting positions so that modifications to plant layout have not affected these.
- Security of mounting
- Sensor flame arrestors for clogging due to water, oil, dust, paint or other contaminants.
- Sensor accessories where fitted
- Condition of fastening of cables.
- Air filters, where fitted
- Operation of complete system on stand-by supplies, where fitted, for the full prescribed time.

### 5.2 Storage

Modules should be stored in a clean dry area and within the temperature range quoted in the Specification (see Section 2):

When prolonged storage is anticipated, modules should be sealed, together with a desiccant, into plastic bags and double wrapped for protection.

## 6.0 Trouble Shooting

### 6.1 Fault codes and Remedies

Faults are stacked according to priority, i.e.: if more than one Fault exists at a particular time, the display will show the Fault with the highest priority (lowest number in priority column). As the Faults are being cleared, the Fault with the next highest priority will be displayed, until all Faults have been cleared.

Latching Faults, except for F07, may be cleared by briefly applying the magnet to the General Monitors Logo on the Nameplate if the Fault condition no longer exists. Non-latching Faults will clear automatically once the Fault condition ceases to exist.

Recovery from F04, F05 and F06 will cause the unit to enter Power up mode as the sensor may have been disconnected or insufficiently biased during the fault condition.

Fault Code	Function	Priority	Mode	Remedy
F01	Analogue output open circuit	6	non-latching	Check wiring and fuse.
F02	Fail to calibration	9	latching	Ensure calibration gas supply is adequate. Re-calibrate. If persistent, replace sensor.
F03	Low response	8	latching	Ensure calibration gas supply is adequate. Re-calibrate. If persistent replace sensor.
F04	Sensor open circuit	5	non-latching	Check wiring and sensor. Replace sensor if necessary.
F05	Sensor short circuit	4	non-latching	Check wiring and sensor. Replace sensor if necessary.
F06	Power low	3	non-latching	Ensure power supply voltage at the instrument's terminal block is within specification.
F07	EEPROM CRC error	2	latching	Ensure 50% LEL calibration gas is available. Power down the instrument. Activate the Remote Cal input and place the magnet on the General Monitors Logo on the Nameplate. Re-apply power, remove the magnet and de-activate Remote Cal. Wait for the instrument to complete its power-up routine. The instrument will automatically enter calibration mode. Calibrate as normal. <b>All user selectable parameters will have returned to their factory default settings and must be re-programmed as required.</b> If F07 persists, the fault condition is terminal and requires the instrument to be returned to General Monitors.
F08	Negative drift > 9.5% LEL	1	non-latching	Re-calibrate. Ensure sensor "sees" no gas when zero reading is taken. If persistent, replace sensor.
F09	Calibration (check) time-out	7	latching	Ensure calibration gas supply is adequate. Re-calibrate and apply or remove calibration gas in timely fashion as prompted by the display. If persistent, replace sensor.

## **6.2 Alarms**

Alarms are stacked below Faults according to priority i.e.: if a Fault and (latched) Alarm(s) exist at a particular time, the display will show the Fault. As the Fault is cleared, the Alarm with the next highest priority will be displayed.

Latched Alarms may be cleared by briefly applying the magnet to the General Monitors Logo on the Nameplate if the Alarm condition no longer exists. Non-latching Alarms will clear automatically once the Alarm condition ceases to exist.

## **6.3 Modbus RTU Serial Interface problems**

If the Modbus Node Address or any other Modbus parameter of the instrument is unknown, proceed as follows:

Power down the instrument. Place the magnet on the General Monitors Logo on the Nameplate. Ensure the Remote Cal input is NOT activated. Re-apply power and remove the magnet. Wait for the instrument to complete its power up routine. All user selectable Modbus parameters will have returned to their factory default settings and may be re-programmed as required.

## 7.0 Ancillary Equipment

### 7.1 Dust Guard Assembly (P/N 10110)



Dust Guard Kit  
(with 12 replaceable  
screens)

The dust guard is a simple, threaded (1 3/16-18 UNEF 2B) stainless steel cylinder with a wire screen at one end. It is easily unscrewed for cleaning and/or replacement of the disposable screen. The screen material is stainless steel with a nominal 40 micron mesh. This General Monitors accessory is specially designed to prevent dust and particulate matter from reaching the sensor flame arrestor. Such debris can plug the sinter and limit the amount of gas reaching the active surface of the sensor, thereby creating a potentially hazardous situation. When the dust guard is installed, this problem is eliminated and sensor response is virtually unchanged. The dust guard is also available in a kit (PIN 10044) with twelve replaceable screens. It can be used as an effective windscreen, and is recommended for corrosive, windy or high temperature environments. A typical application would be in the area surrounding a drying oven.

### 7.2 Sintered Stainless Steel Dust Guard (P/N 1800822-1)

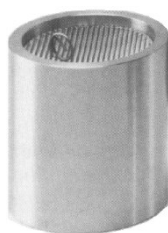

The construction of this accessory is similar to P/N 10110, but with 3mm (1/8") thick sintered stainless steel disc at one end. The body material is stainless steel with an internal 3/16 UNEF 2B thread for installation on the sensor body. This dust guard provides protection from fine particulates and windy environments. It should be used only in dry locations because of the tendency of the sintered disc to absorb water which will then act as a gas diffusion barrier until the disc has dried out again. **Sensor response time is affected by the dust guard. It should not be removed during sensor calibration.**

### 7.3 Splash Guard (P/N 10395-1)



The Splash Guard is a rugged thermoplastic polyester (Valox) plastic cylinder which screws into place over the sensor body. It contains a series of internal baffles which are designed to deflect water spray away from the sensor flame arrestor. The splash guard is recommended for areas where heavy rain or frequent equipment hosedowns occur. It also makes an effective barrier against high winds. **Sensor response time is affected by the splash guard. It should not be removed during sensor calibration.**

### 7.4 Sensor Flow Chamber (P/N 10066)

The General Monitors Sensor Flow Chamber is constructed of 2024T aluminium (optional stainless steel type 316, P/N 10066-SS). The chamber has an internal thread 1 3/16-18 UNEF 2B, into which a sensor may be screwed, and two threaded ports (1/8 27 NPT L1 NOM) which accept 1/4" tube fittings (P/N 925-029). The chamber is designed for insertion into a sampling system and the recommended flow rate is 0.47 litres per minute (1 cu. ft/hr.)

## 7.5 Duct Mounting Plate (P/N 10041 Dash-1 or -2)

The Duct Mounting Plate is a rectangular plate measuring 73 x 116mm (2.88" x 4.56") containing four captive mounting screws (6-32 UNC), and fitted with a Neoprene O-ring seal. The sensor is mounted in a 1 3/16-18 UNEF threaded hole in the centre of the plate. The assembly is ideally suited to the monitoring of ducted air for living quarters in large offshore modules. Note that the sensor should be mounted pointing down, protected for excessive air velocity and in a position to facilitate recalibration.

## 7.6 Portable Purge Calibrator – Model 1400150

General Monitors Portable Purge Calibrator is a compact, accurate and safe field calibration system.

No hazardous gas to handle – The Calibrator is filled with a Gas/Air mixture below the Lower Explosion Level. (Standard mixture is 50% LEL).

Known Gas/Air Mixture – Eliminate the chance of error in field calibration

Hose and Cup Adapter – Permits you to calibrate your sensors without dismounting them.

Available Gases – Premixed calibration gases at approximately 50% LEL.

Butane	C <sub>4</sub> H <sub>10</sub>
Hydrogen	H <sub>2</sub>
Methane	CH <sub>4</sub>
Propane	C <sub>3</sub> H <sub>8</sub>

Maximum Permissible Pressure in the lecture bottle is 1200 psia

Spare Gas Bottles – Order Part No. 1400155 and specify gas. Bottles are inexpensive and may be returned for refilling.

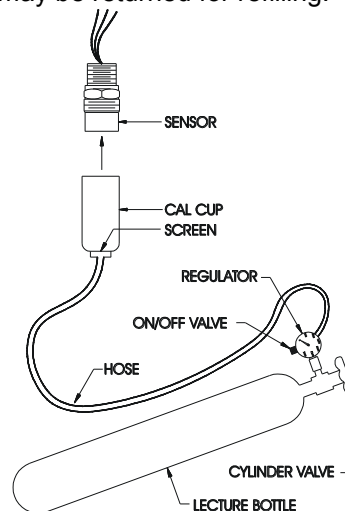



**Available from stock**

Portable Purge Calibrator Methane Gas 50% LEL	1400150-M	Replacement Cylinder Hydrogen 50% LEL	140155-H
Portable Purge Calibrator Hydrogen Gas 50% LEL	1400150-H	Replacement Cylinder Butadine Gas 50% LEL	140155-BD
Portable Purge Calibrator Butadine Gas 50% LEL	1400150-BD	Replacement Cylinder Butane Gas 50% LEL	140155-B
Portable Purge Calibrator Butane Gas 50% LEL	1400150-B	Replacement Cylinder Ethane Gas 50% LEL	140155-E
Portable Purge Calibrator Ethane Gas 50% LEL	1400150-E	Replacement Cylinder Propane Gas 50% LEL	140155-P
Portable Purge Calibrator Propane Gas 50% LEL	1400150-P	Cylinder Refill Methane Gas 50% LEL	140015-M
Small Calibration Cup	1400152-1	Cylinder Refill Hydrogen Gas 50% LEL	140015-H
Large Calibration Cup	1400154	Cylinder Refill Propane Gas 50% LEL	140015P
Regulator, Pressure Guage	922-009	Cylinder Refill Butane Gas 50% LEL	140015-B
Replacement Cylinder Methane Gas 50% LEL	140155-M		

**Portable Purge Calibrator Operating Instructions**

1. Allow the Model S4100C to stabilise for 1 hour. Ensure that the sensor is in clean air i.e. there is no gas present. Put the unit into Calibration Mode, wait until "AC" is displayed.
2. Turn the main valve on the lecture bottle counter clockwise until pressure is indicated on the gauge. Gas flow is now controlled by the low pressure, lever operated valve. Turn the gas "on" by means of valve.
3. Place the plastic cup over the outer sensor guard (Two cup sizes are supplied; cup should fit closely but not seal).

**CAUTION: DO NOT ADJUST THE REGULATOR. IT IS FACTORY ADJUSTED FOR OPTIMUM FLOW.**

4. Wait until "CC" is displayed.
5. Release the lever-operated valve, stopping the flow of gas through the plastic tube. Remove the cup from the sensor (Reading should return to zero)
6. Turn off gas by valve, then turn the main valve clockwise to turn the gas off.
7. Your Combustible gas detection system is now calibrated to the LEL mixture of the Portable Purge Calibrator.

## 7.7 Remote Test Gas Applicator – TGA-1

The Remote Test Gas Applicator, (TGA-1) is designed to be permanently installed on a combustible gas sensor. The TGA-1 provides protection from outside elements, such as splashing water, and it allows the user to apply test gas from a remote source.

### Special Instructions

1. For best results when using the TGA-1, test gas readings should not be accepted unless the surrounding air is essentially motionless. If used outdoors, wind may considerably reduce gas concentration. With wind speeds up to 13mph, the accuracy of the test gas and/or calibration will be within approximately  $\pm 20\%$  of the applied gas.
2. The flow rate of the applied gas should be set at approximately 400ml/minute.
3. Allow adequate time for the air to be displayed from any interconnecting pipe before noting test gas readings.
4. Calibration should be checked periodically using portable purge calibrator, Part No. 1400150.

### Part Numbers

10460-1 TGA-1	1/4" Brass fitting
10460-2 TGA-1	1/4" Stainless Steel Fitting
10460-3 TGA-1	6mm Stainless Steel Fitting

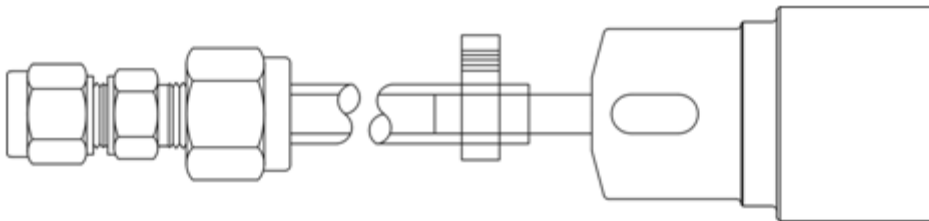

## 7.8 Volatile Liquids and Solvents

Volatile liquids and solvents are not supplied by General Monitors. This page provides a listing of some volatile liquids and solvents and the respective volumes required (in microlitres) to produce a 50% LEL vapor concentration in the **3 Litre Portable Calibration Chamber (P/No. 10543-1)** – a hypodermic syringe is provided for the accurate measurement and insertion of the precise volumes into the Chamber. (These volumes are correct at 25°C and 1 Atmosphere pressure. If using significantly outside these “STP” values, please consult the factory.)

Acetaldehyde .....	136	Isoprene (2-Methyl-1,3-Butadiene)	89
Acetic Acid.....	140	JP-4, Jet Fuel mainly Kerosene)	183
Acetone .....	112	Methanol (Methyl Alcohol) .....	148
Acetonitrile.....	96	Methyl Ethyl Ketone (MEK) .....	76
Acrylonitrile.....	120	Methyl Metacrylate.....	111
Amyl Acetate .....	100	Methyl-t-Butyl Ether (MTBE).....	109
Benzene .....	65	Naptha (Petroleum Ether).....	96
Butyl Acetate .....	137	Octane .....	99
Butyl Alcohol (1-Butanol).....	78	Pentane, Normal.....	105
sec-Butyl Alcohol (2-Butanol).....	95	Isopropyl Alcohol (IPA) .....	93
tert-Butyl Alcohol .....	138	n-Propanol .....	100
Butyraldehyde .....	102	Propylacetate.....	120
Cyclohexane .....	86	Propylamine .....	103
Diethyl Ketone (3-Pentanone)..	103	Propylene Oxide .....	98
p-Dioxane .....	104	Styrene (Vinly Benzene).....	63
Ethanol (Ethyl Alcohol).....	118	Tetrahydrofuran .....	99
Ethyl Acetate .....	119	Toluene (Methylbenzene, Toluol) .	78
Ethyl Amine .....	140	Triethylamine .....	102
Ethyl Benzene .....	60	o-Xylene.....	68
Ethyl Ether.....	120	p-Xylene.....	83
Gasoline .....	107	m-Xylene.....	83
Heptane.....	94	Xylenes .....	83
Hexane .....	86		
Isopentane (2-Methylbutane) .....	99		

## 8.0 Modbus RTU Serial Interface

### 8.1 General

The Modbus communications interface is based on the RS485 standard. It is implemented as a 2 wire, half-duplex, balanced differential interface which conforms to the EIA-485 specification. Each slave device must have its unique address so that more than one device can be connected to an independently addressed on the same RS485-link.

The Smart Transmitter Interface implements the RTU protocol as described in the “Modicon Protocol Reference Guide PI-MBUS-300 Rev. G. The Modbus RTU is an asynchronous NRZ format. The RTU mode and serial format must be the same for all devices on a Modbus network. The instrument acts as a Modbus communications “Slave”.

Two Modbus connections (Modbus 1 and Modbus 2), are provided, sharing the node address and all other Modbus parameters.

The device receives and transmits on both connections simultaneously, requiring the host for Modbus 2 to be quiescent when Modbus 1 connection is active and vice versa.

The Modbus interface factory defaults are set to Node Address 1, 19K2 baud, no parity and 1 stop bit. When the instrument is powered up, the Modbus setup defaults to the settings used before it was powered down. The interface supports a maximum of 2 bits for stop bit and parity information. A selection of 2 stop bits causes no parity to be implemented.

The Modbus Interface and Menu Interface can be used simultaneously for Modbus read commands only. For write commands, the operation is mutually exclusive. Any attempts to perform a Modbus write are inhibited while the Menu Interface is active. This is indicated by returning the Slave Device Busy response (Exception Code 6).

### 8.2 Modbus Message Characteristics

Baud rate	2K4, 4K8, 9K6 or 19K2
Byte length (11 bits) max	11 / (Baud rate) ms
Inter message spacing or Modicon specification min	3.5 bytes
Inter byte spacings per Modicon specification min/max	0 bytes / 1.5 bytes
Number of Bytes per message min/max	7 / 15

### 8.3 Modbus Exception Codes

Code Name	Description	Hex value
Illegal function	Function code is not recognised by the slave	01
Illegal data address	Data address specified is not supported by the slave	02
Illegal data value	Data value specified is not supported by the slave	03
Slave device busy	The slave is engaged in completing a long duration programme command	06

## 8.4 Modbus Read/Write - Commands

Function Code	Description	Access Type
1	Read coil status	Read
2	Read input status	Read
3	Read holding registers	Read
4	Read input registers	Read
5	Force single coil	Write
6	Preset single register	Write
15	Force multiple coils	Write
16	Preset multiple registers	Write

Any of commands with Function Code 1, 2, 3, 4 allow data to be read from the instrument. The message structure for each read command specifies a start register address. A maximum of 5 consecutive registers can be accessed including the start register address. Each register configures the data as 2 bytes with the most significant byte first. If more than 5 registers are addressed or if there is an attempt to access any register outside the valid read register address space, the Illegal Data Address response (Exception Code 2) is returned.

Any of the commands with Function Code 5, 6 15, 16 allow write data to be written to the instrument. The message structure for each write command specifies a register address to which data is written. The message structure for each multiple write command (15, 16) specifies a register address with the byte count set at 2 to allow single register access. If more than 1 register is addressed or if there is an attempt to access any register outside the valid write register address space, the Illegal Data Address response (Exception Code 2) is returned. Broadcast mode uses address 0 and sends the same data to all attached slaves.

The issue of a write command to a single valid write register normally causes all of the data specified to be overwritten. In certain situations, it is impossible to force a condition due to the presence of an external event e.g. attempts to clear a fault while the fault condition is still present results in the fault not being cleared. For other situations, any attempts to assign unused, read-only or out of range values will have no effect. **It is advisable to issue a read of the same register range to verify the true data value present subsequent to the write cycle.**

## 8.5 Modbus Register Configuration

Registers 1, 2, 4, 5, 6, 8 & 11 contain the value of the single parameter specified, the remaining registers contain composite parameters. Attempts to write a data value out of range for these parameters will result in the Illegal Data Value response (Exception Code 3). Unused bits are set to 0.

Register	Function	Access Type	Hex address	Scaling
1	Analogue output current	Read	00	0mA =0x8000 20mA =0xFFFE
2	Sensor response at calibration in % of reference	Read	01	0% =0x8000 1000% =0xFFFE
3	Alarm, fault and analogue output status	Read	02	NA
4	Calibration level setup	Read	03	0 =0x8000 100 =0xFFFE
5	A1 alarm trip level setup	Read/write	04	0 =0x8000 100 =0xFFFE
6	A2 alarm trip level setup	Read/write	05	0 =0x8000 100 =0xFFFE
7	Open collector outputs and analogue output current at calibration setup	Read/write	06	NA
8	Number of successful calibrations	Read/write	07	0 =0x0000 65535 =0xFFFF
9	Modbus setup	Read/write	08	NA
10	Clear latched alarms and faults	Write	09	NA
11	Sensor response at calibration reference in mV	Read	10	0V =0x8000 10V =0xFFFE

### 8.5.1 Register 3

A bit value of 1 denotes that the corresponding element is active. A bit value of 0 denotes that the corresponding element is inactive. All of the 16 bits in the register are simultaneously accessed during a read.

Description	Alarm/Fault Type	Bit Position
A2 Alarm	Latching/Non-latching	15
A1 Alarm	Latching/Non-latching	14
Analogue output at cal level	-	13
-	-	12
-	-	11
-	-	10
F09 calibration (check) time-out	Latching	9
F08 Negative drift > 9.5% LEL	Non-latching	8
F07 EEPROM CRC error	Latching	7
F06 Power low	Non-latching	6
F05 Sensor short circuit	Non-latching	5
F04 Sensor open circuit	Non-latching	4
F03 Low response	Latching	3
F02 Fail to calibrate	Latching	2
F01 Analogue output open circuit	Non-latching	1
-	-	0

### 8.5.2 Register 7

Description	Bit position	Dec. value	Function
-	15-6	0	-
Analogue output at calibration	5-4	0 1 2	0.0mA 1.5mA 2.0mA
A2 alarm open collector output normally energised/de-energised	3	0 1	De-energised Energised
A1 alarm open collector output normally energised/de-energised	2	0 1	De-energised Energised
A2 alarm open collector output normally latching/non-latching	1	0 1	Non-latching Latching
A1 alarm open collector output normally latching/non-latching	0	0 1	Non-latching Latching

### 8.5.3 Register 9

Description	Bit position	Dec. value
Node address	15-8	1-255
1 stop bit	7	0
2 stop bits		1
No parity	6-5	0
Odd parity		1
Even parity		2
-	4-2	0
Baud rate 19200	1-0	0
Baud rate 9600		1
Baud rate 4800		2
Baud rate 2400		3

The Node address specified in the high data byte is not written during a broadcast write of the register.

### 8.5.4 Register 10

The clear register is written a value of 1 to clear a latched Fault or Alarm indicated in the status register. Each issue of the clear command clears a single latched Fault or Alarm in order of priority, provided the Fault or Alarm condition no longer exists.

## 9.0 Appendix A

### 9.1 Maximum Sensor Cable Length

**Note:** Cables to be screened and armoured to BS5308 Part 2 or equivalent. References to Sq. mm and AWG are not to be taken as direct equivalents.

Maximum Sensor Cable length for various conductor sizes:

Conductor Size		Maximum Cable Length	
Sq. mm	AWG	metres	feet
0.75	20	185	500
1.0	18	250	780
1.5	16	370	1000
2.0	14	500	1580
2.5	12	620	2400

### 9.2 Maximum Smart Transmitter Cable Length

Maximum Smart Transmitter Cable Length for various conductor sizes and power supply voltages with a 100mA load on each of the three open collector outputs:

**Note:** When open collector outputs are not connected, use values in parenthesis.

Conductor Size		Maximum Cable Length				Power Supply Rating		Cable Drop
sq mm	AWG	metres		feet		VDC	mA max	total VDC
0.75	20	160	(330)	440	(910)	35.0	575 (275)	5.0
1.0	18	215	(450)	680	(1420)			
1.5	16	320	(660)	860	(1820)			
2.0	14	430	(900)	1375	(2850)			
2.5	12	535	(1125)	2100	(4400)			
0.75	20	290	(550)	800	(1520)	35.0	630 (330)	10.0
1.0	18	390	(750)	1220	(2375)			
1.5	16	580	(1100)	1600	(3025)			
2.0	14	780	(1500)	2500	(4800)			
2.5	12	975	(1875)	3800	(7380)			
0.75	20	390	(680)	1050	(1850)	35.0	710 (410)	15.0
1.0	18	520	(900)	1650	(2850)			
1.5	16	780	(1360)	2110	(3670)			
2.0	14	1040	(1800)	3350	(5775)			
2.5	12	1300	(2250)	5150	(8850)			
0.75	20	290	(550)	800	(1520)	30.0	630 (330)	5.0
1.0	18	390	(750)	1220	(2375)			
1.5	16	580	(1100)	1600	(3025)			
2.0	14	780	(1500)	2500	(4800)			
2.5	12	975	(1875)	3800	(7380)			
0.75	20	390	(680)	1050	(1850)	30.0	710 (410)	10.0
1.0	18	520	(900)	1650	(2850)			
1.5	16	780	(1360)	2110	(3670)			
2.0	14	1040	(1800)	3350	(5775)			



Conductor Size		Maximum Cable Length				Power Supply Rating		Cable Drop
sq mm	AWG	metres		feet		VDC	mA max	total VDC
2.5	12	1300	(2250)	5150	(8850)			
0.75	20	430	(675)	1190	(1825)	30.0	850 (550)	15.0
1.0	18	575	(900)	1850	(2850)			
1.5	16	860	(1350)	2350	(3650)			
2.0	14	1150	(1800)	3730	(5775)			
2.5	12	1435	(2250)	5725	(8850)			
0.75	20	125	(215)	325	(575)			
1.0	18	165	(280)	525	(900)			
1.5	16	250	(430)	675	(1150)			
2.0	14	330	(560)	1050	(1825)			
2.5	12	410	(700)	1650	(2825)			
0.75	20	210	(315)	550	(850)	24.0	885 (585)	10.0
1.0	18	275	(420)	875	(1325)			
1.5	16	420	(630)	1125	(1700)			
2.0	14	550	(840)	1175	(2700)			
2.5	12	675	(1050)	2750	(4150)			
1.0	18	23	(32)	73	(100)			
1.5	16	34	(48)	94	(130)			
2.0	14	46	(64)	150	(210)			
2.5	12	57	(80)	230	(325)			
4.0	--	92	(128)	--	--			
1.0	18	44	(60)	135	(190)	12.0	1118 (818)	2.0
1.5	16	66	(90)	175	(240)			
2.0	14	88	(120)	280	(380)			
2.5	12	110	(150)	430	(590)			
4.0	--	176	(240)	--	--			

# Customer Satisfaction Questionnaire

## Attention Field Operations:

We would appreciate your help in assessing and thus improving the quality of our Equipment and Service and would therefore be grateful if you would complete the Questionnaire below and return it to:

General Monitors Ireland Ltd,  
Ballybrit Business Park,  
Galway,  
Republic of Ireland.

**Thank you for your assistance**

Client \_\_\_\_\_

Client Order No. \_\_\_\_\_

General Monitors Sales Order No. \_\_\_\_\_

(Please tick appropriate box)	Yes	No
1. Was the equipment the correct option?	<input type="checkbox"/>	<input type="checkbox"/>
2. Are sensors correct type and range?	<input type="checkbox"/>	<input type="checkbox"/>
3. Is mechanical assembly good? (everything proper fit and tight)	<input type="checkbox"/>	<input type="checkbox"/>
4. Did you receive the necessary accessories to commission the equipment?	<input type="checkbox"/>	<input type="checkbox"/>
5. Has the equipment been commissioned?	<input type="checkbox"/>	<input type="checkbox"/>
6. Any problems encountered during commissioning?	<input type="checkbox"/>	<input type="checkbox"/>
7. Is the equipment functioning correctly at present?	<input type="checkbox"/>	<input type="checkbox"/>

If you have answered **NO** to any of the above, please provide further details overleaf. **Thank you.**

Completed by: \_\_\_\_\_

Date: \_\_\_\_\_