

Operating Manual  
**PrimaX<sup>®</sup> IR**  
Infrared Gas Monitor



MSA AUER GmbH  
Thiemannstrasse 1  
D-12059 Berlin

Germany

© MSA AUER GmbH. All rights reserved



## EC Declaration of Conformity

MANUFACTURED BY: Mine Safety Appliances Company  
1000 Cranberry Woods Drive  
Cranberry Township, PA 16066 USA

The manufacturer or the European Authorized Representative  
**MSA AUER GmbH**  
**Thiemannstraße 1**  
**D-12059 Berlin**

declares that the product

**PrimaX IR**

based on the EC-Type Examination Certificate:

**BVS 10 ATEX E 157 X**

complies with the ATEX directive 94/9/EC, Annex III. Quality Assurance Notification complying with Annex IV of the ATEX Directive 94/9/EC has been issued by Ineris of France, Notified Body number: 0080.

Standards: EN 60079-0:2009, EN 60079-1:2007, IEC 60079-31:2009,  
EN 60079-29-1:2007, EN 50271:2010

The product is in conformance with the directive 2004/108/EC, [EMC]:  
EN 50270:2006 Type 2, EN 61000-6-4:2007

A handwritten signature in black ink, appearing to read 'Dr. A. Schubert'.

MSA AUER GmbH  
Dr. Axel Schubert  
R&D Instruments

Berlin, June 2013



## EC Declaration of Conformity

MANUFACTURED BY: Mine Safety Appliances Company  
1000 Cranberry Woods Drive  
Cranberry Township, PA 16066 USA

The manufacturer or the European Authorized Representative  
**MSA AUER GmbH**  
**Thiemannstraße 1**  
**D-12059 Berlin**

declares that the product

### **PrimaX IR Calibration Cap**

based on the EC-Type Examination Certificate:

### **LCIE 10 ATEX 3090**

complies with the ATEX directive 94/9/EC, Annex III. Quality Assurance Notification complying with Annex IV of the ATEX Directive 94/9/EC has been issued by Ineris of France, Notified Body number: 0080.

Standards: EN 60079-0:2006, EN 60079-11:2007

The product is in conformance with the directive 2004/108/EC, [EMC]:

EN 61000-6-2:2005, EN 61000-6-3:2007

A handwritten signature in black ink, appearing to read 'Dr. A. Schubert'.

MSA AUER GmbH  
Dr. Axel Schubert  
R&D Instruments

Berlin, June 2013

## Contents

<b>1</b>	<b>Safety Regulations .....</b>	<b>7</b>
1.1	Correct Use .....	7
1.2	Liability Information .....	8
1.3	Safety and Precautionary Measures to be Adopted .....	8
1.4	MSA Permanent Instrument Warranty .....	9
<b>2</b>	<b>Description .....</b>	<b>10</b>
2.1	User Interface .....	10
2.2	Package Contents .....	11
<b>3</b>	<b>Installation .....</b>	<b>13</b>
3.1	Mechanical Installation .....	13
3.2	Electrical Installation .....	17
<b>4</b>	<b>Start-up and Calibration .....</b>	<b>20</b>
4.1	Initial Startup .....	20
4.2	PrimaX IR Calibration .....	22
4.3	Calibration Kits .....	31
<b>5</b>	<b>Maintenance .....</b>	<b>32</b>
5.1	General .....	32
5.2	Troubleshooting .....	32
5.3	HART Information for Troubleshooting .....	34
5.4	Cleaning .....	34
5.5	Environmental Guard Cleaning .....	36
5.6	Calibration Cap Cleaning Procedure .....	37
<b>6</b>	<b>Technical Data .....</b>	<b>38</b>

<b>7</b>	<b>Accessories .....</b>	<b>39</b>
7.1	Flow Cap .....	39
7.2	Sunshield .....	40
7.3	Duct Mount Flange .....	40
7.4	HART Module .....	41
7.5	Insect Guard/Remote Calibration Inserts .....	42
<b>8</b>	<b>Approvals .....</b>	<b>43</b>
8.1	Marking, Certificates and Approvals According to the Directive 94/9/EC ATEX 43	
8.2	Marking, Certificates and Approvals According to IECEx .....	47
8.3	Special conditions for the safe use according to ATEX and SIL applications .....	50

# 1 Safety Regulations

## 1.1 Correct Use

The PrimaX IR Gas Monitor - referred to hereafter as device - is a fixed infrared combustible gas detector. It is suitable for outdoor and indoor applications, e.g. off-shore industry, chemical and petrochemical industry, water and sewage industry.

The device utilises infrared technology to monitor, detect and alert users to potentially dangerous levels of combustible hydrocarbon gas. Dual source technology offers 100% redundancy on the optical source to maximize reliability and lifetime. This device allows for extremely fast response time whilst providing an extremely stable output signal.

The device is a stand-alone unit with a 4 to 20 mA output with HART [Highway Addressable Remote Transducer] digital information encoded on the analogue output. The signal of the transmitter can be used in combination with MSA control units for further actions in safety or non-safety applications. Contact your MSA representative for available controllers.

The device is shipped factory-calibrated and is labelled with target gas, calibration gas and span setting information for ease of use. Any user changes to the factory assigned values should be noted on the device labels.

The device is explosion-proof and suitable for installation in hazardous locations. This sensor is intended for integration with a control system that can alert operations personnel to the presence of hydrocarbon combustible gas.

It is imperative that this operating manual be read and observed when using the product. In particular, the safety instructions, as well as the information for the use and operation of the product, must be carefully read and observed. Furthermore, the national regulations applicable in the user's country must be taken into account for a safe use. This includes EN 60079-29-2.



### **Danger!**

This product is supporting life and health. Inappropriate use, maintenance or servicing may affect the function of the device and thereby seriously compromise the user's life.

Before use the product operability must be verified. The product must not be used if the function test is unsuccessful, it is damaged, a competent servicing/maintenance has not been made, genuine MSA spare parts have not been used.

Alternative use, or use outside this specification will be considered as non-compliance. This also applies especially to unauthorised alterations to the product and to commissioning work that has not been carried out by MSA or authorised persons.

## 1.2 Liability Information

MSA accepts no liability in cases where the product has been used inappropriately or not as intended. The selection and use of the product are the exclusive responsibility of the individual operator.

Product liability claims, warranties also as guarantees made by MSA with respect to the product are voided, if it is not used, serviced or maintained in accordance with the instructions in this manual.

## 1.3 Safety and Precautionary Measures to be Adopted



### Attention!

The following safety instructions must be observed implicitly. Only in this way can the safety and health of the individual operators, and the correct functioning of the device, be guaranteed.

- The device described in this manual must be installed, operated and maintained in strict accordance with the labels, cautions, instructions, and within the limitations stated.
- Protect the device from extreme vibration.
- Do not mount the device in direct sunlight, since this may cause it to overheat. A stainless steel sunshield is available for the PrimaX IR Gas Monitor to protect it from extreme environments.
- The only absolute method to ensure proper overall operation of the device is to check it with a known concentration of the gas for which it has been calibrated. Consequently, calibration checks must be included as part of the routine inspection of the system. The device is labelled with the type and value of the factory calibration gas.
- Use only genuine MSA replacement parts when performing any maintenance procedures provided in this manual. Failure to do so may seriously impair device performance. Repair or alteration of the device, beyond the scope of these maintenance instructions or by anyone other than an authorised MSA service provider, could cause the product to fail to perform as designed.
- There are NO field-repairable internal components for this device. Return to MSA for warranty replacement per the Warranty section.
- This device does NOT detect the presence of hydrogen gas and must never be used to monitor for hydrogen gas.
- The standard device must never be used in atmospheres containing acetylene gas. Contact MSA regarding available acetylene sensors.



- Calibrate frequently if used in atmospheres exposed to high levels of solvents or dust. See chapters 4 and 5 for calibration and cleaning procedures.
- Do not paint the device. If painting is done in an area where the device is located, exercise caution to ensure paint is not deposited on the device. Such paint deposits could interfere with the device operation. Solvents in the paint may also cause an alarm condition to occur.
- The device is designed for applications in hazardous areas under environmental conditions defined in the Specifications section of this manual.
- The response time of the device can be increased by significant dust deposits. Checks for dust deposits must be done at regular intervals.
- The PrimaX IR sensor will detect other hydrocarbon gases than the target gas.
- Oxygen enriched atmospheres greater than 21 Vol% can affect the measurement and the electrical safety of the Gas Monitor.

## 1.4 MSA Permanent Instrument Warranty

### Warranty

Seller warrants that this product will be free from mechanical defect or faulty workmanship for

- IR Dual source: ten [10] years from date of shipment, as determined by HART communication that both sources are non-functional
- Gas Monitor, excluding accessories: three [3] years from date of shipment
- Calibration cap: one [1] year from date of shipment

This warranty is applicable provided the product is maintained and used in accordance with Seller's instructions and/or recommendations.

The Seller shall be released from all obligations under this warranty in the event repairs or modifications are made by persons other than its own or authorized service personnel or if the warranty claim results from physical abuse or misuse of the product. No agent, employee or representative of the Seller has any authority to bind the Seller to any affirmation, representation or warranty concerning the goods sold under this contract. Seller makes no warranty concerning components or accessories not manufactured by the Seller, but will pass onto the Purchaser all warranties of manufacturers of such components.

## 2 Description

The device is designed to sample the environment at the installed location and alert the user to potentially dangerous levels of hydrocarbon gas. The device is shipped factory calibrated and is labelled with target gas, calibration gas and span setting information.

The output of the device is a standard 4 to 20 mA with HART. The 4-20 mA signal communicates the primary measured value using the 4-20 mA current loop. Additional device information is communicated using a digital signal that is superimposed on the analogue signal. The device is compliant with HART Communications Foundation [HCF] Revision 7.0 format. Commercially available hand-held communicator devices or PC applications can be used to communicate with the device using the Device Description [DD] file that is available from the HART Communications Foundation website [[www.hartcomm.org](http://www.hartcomm.org)].

### 2.1 User Interface

This device does not provide a visual display of information. The gas level and basic device status are available via the 4-20 mA output signal. Other detailed device status is available via the HART signal. Details about this interface can be found in the PrimaX IR HART Specification located on the product CD shipped with the device.

The optional calibration cap provides an LCD display for easy and intuitive calibration of the device. The proper usage of this calibration cap is described in chapter 4.3.1.

The device should be installed where gas leaks are anticipated. The installation position depends on the gas density, either in the upper area of the room beneath the ceiling for gases lighter than air, or close to the ground for gases heavier than air. Also consider how air movement may affect the ability of the device to detect gas. Testing for ventilation patterns may be helpful in establishing locations for the device in enclosed areas.



Before beginning the installation, check that the delivered components are complete and correct, referring to the shipping documents and the label on the shipment carton.

---

## 2.2 Package Contents

The device will be delivered with the following items in the shipping carton:

- PrimaX IR sensor [316 Stainless Steel]
- Environmental guard
- Quick Start Guide
- Product CD, including this instruction manual, HART specification and installation drawing

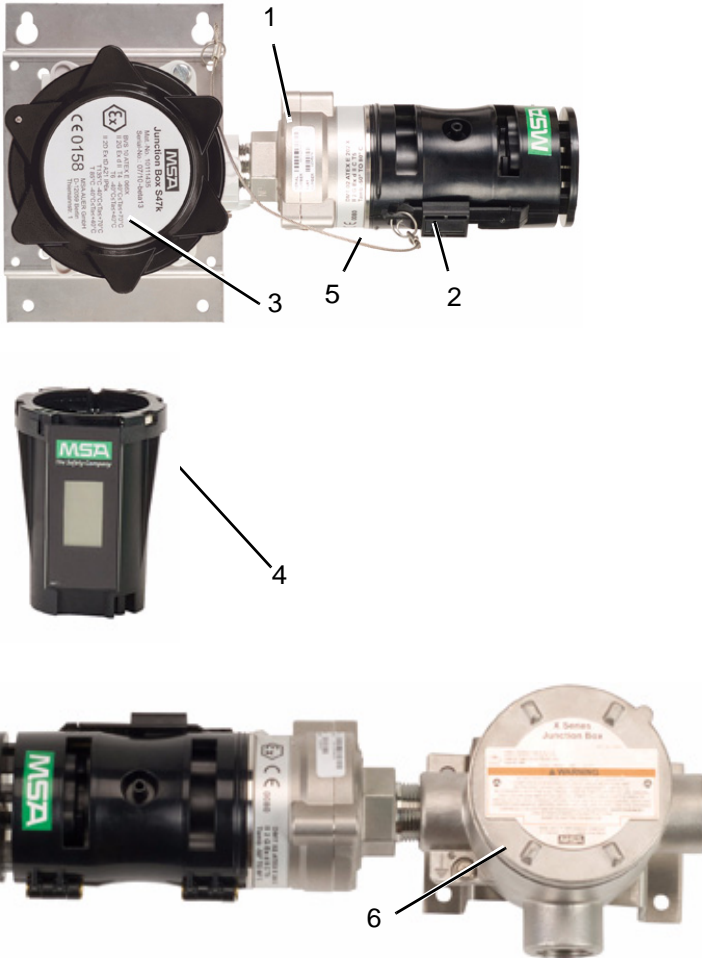

Fig. 1 Overview of Prima X IR parts

- |   |  |   |   |
|---|--|---|---|
| 1 | PrimaX IR sensor [316 stainless steel] | 4 | Calibration cap [optional]                                |
| 2 | Environmental guard                    | 5 | Stainless steel tether for environmental guard [optional] |
| 3 | Aluminium junction box [optional]      | 6 | Stainless steel junction box [optional]                   |

Accessories to be used with this product may be packaged separately. Check the enclosed shipping papers to identify all PrimaX IR accessories that have been ordered.

Accessories available for the PrimaX IR Gas Monitor include:

- Optional junction box equipped with a terminal strip for easy wiring
- Optional calibration cap for calibration operations
- Optional tether strap for environmental guard

The complete list of accessories is provided in chapter 7.

The device will be labelled with the information shown below:

- Target gas, calibration gas and span value
- Serial number and date of manufacture
- Area classification markings

## 3 Installation

### 3.1 Mechanical Installation

The device's dimensions are shown below [mm]:

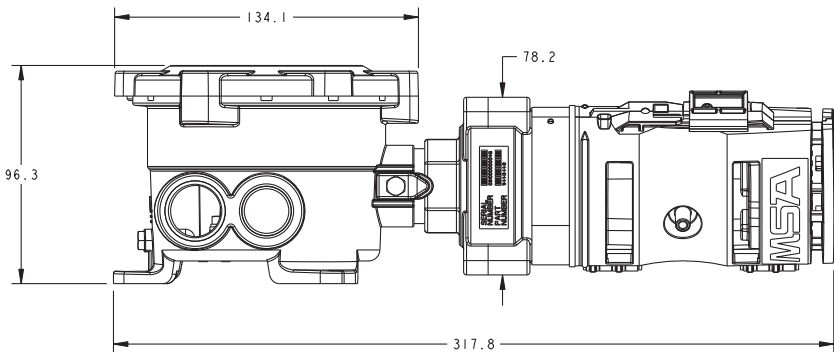

Fig. 2 Sensor with Aluminum Junction Box

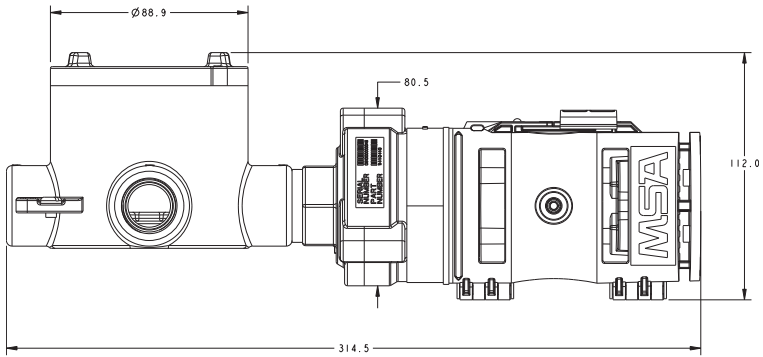

Fig. 3 Sensor with Stainless Steel Junction Box

The sensor is available with either M25 metric threads or 3/4" NPT threads.

If a junction box is not being used, mount the device on a support by using suitable hardware [not supplied], and in accordance with local regulatory requirements.



MSA recommends mounting the sensor horizontally. Horizontal mounting will help prevent the build-up of particulate or liquid matter on the monitor's optical surfaces.

To ensure specified response time mount the sensor with the legs horizontal relative to each other as shown in Fig. 4.

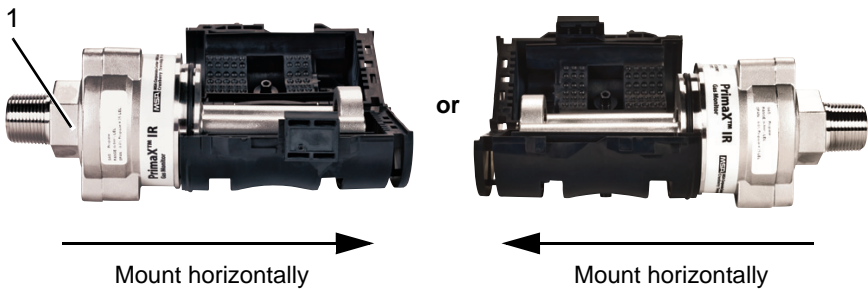

Fig. 4 Recommended mounting orientation

- 1 Hex nut size:  
36mm - Metric  
1-7/16 - Standard

**Attention!**

Do not paint the device. If painting is done in an area where a sensor is located, exercise caution to ensure paint is not deposited on the sensor. Such paint deposits could interfere with the device operation. Solvents in the paint may also cause an alarm condition to occur.

**Attention!**

Protect the device from extreme vibration. Do not mount the sensing head in direct sunlight, since this may cause the sensor to overheat. A stainless steel sunshield is available for the device to protect it from extreme environments.

**Attention!**

During sensor installation or removal, do not use any tools or apply excessive force to the two legs that support the unit's reflectors. Applying force to the legs can permanently damage the monitor.

MSA recommends that the device's environmental guard should be installed on the unit at all times. If the device is to be operated without the guard, frequent checks must be made to ensure particulate or liquid matter has not collected on the windows.

- Use a 36 mm wrench on the hex nut in the sensor neck to install or remove the sensor.
  - ▷ Do not apply torque to the two sensor legs.

**Optional Junction Box Instructions:**

If installing the device on a junction box, verify that the junction box area classification is appropriate for the installation environment. Two options are available for MSA junction boxes:

- Powder-coated aluminium ["d" or "e" version]
- 316 Stainless Steel ["d" version only]

A stainless steel mounting plate is included with either junction box to ensure that there is sufficient clearance from the installed surface [→ fig. 5 and 6].

- (1) Install the mounting bracket and junction box using the bracket holes as the drilling template.

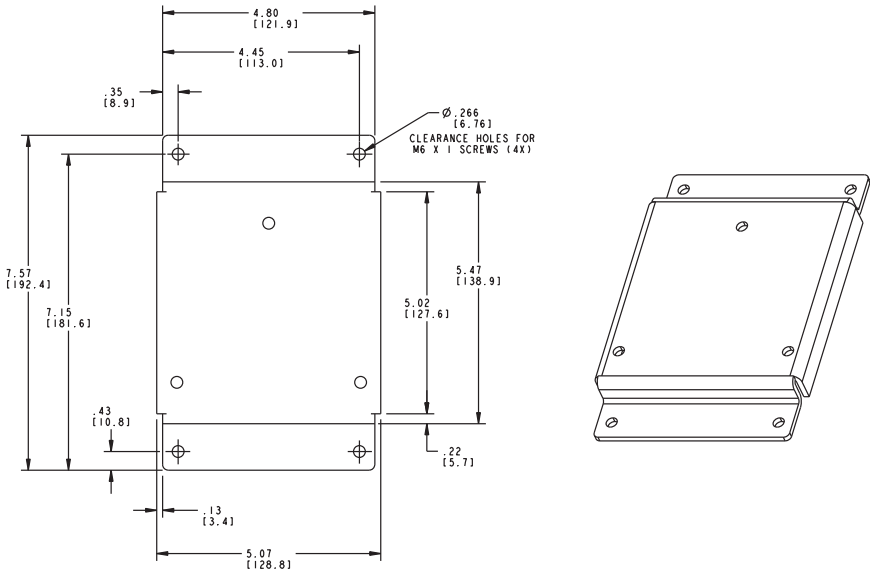

Fig. 5 Mounting bracket for aluminium junction box

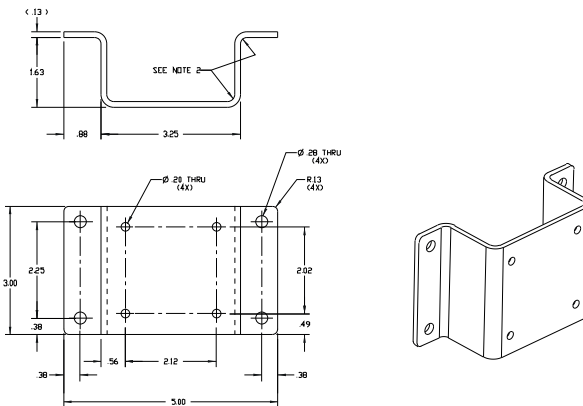

Fig. 6 Mounting bracket for stainless steel junction box

- (2) If not using an MSA supplied junction box, refer to fig. 2 for the dimensional drawing to ensure that there is adequate clearance. Ensure that the environmental guard can be easily removed and re-installed.
- (3) The optimum orientation for the device is horizontal.



## 3.2 Electrical Installation

### Instructions for Electrical Connection



#### Attention!

The device must be installed only in compliance with the applicable regulations, otherwise the safe operation of the device is not guaranteed.

- Shielded cable for measuring devices is recommended.
- Always observe maximum cable lengths and cross-sections shown below.
- Water or impurities can penetrate the device through the cable. In hazardous areas, it is recommended to install the cable in a loop just before entry into the device or to slightly bend it to prevent water from entering.

### Wiring Requirements

The device is a three-wire transmitter that operates in the current source mode and can be wired directly to the input wires or with an optional junction box. The following table provides typical cable lengths and wire sizes for installation. The HART signal requires a load across the signal.

<b>Wire Size vs Distance</b>			
<b>Power Supply Voltage</b>	<b>1.0mm<sup>2</sup></b>	<b>1.5mm<sup>2</sup></b>	<b>Signal Load [including termination]</b>
24 Volts	480 m	720 m	With HART 250 ≤ load ≤ 500 Ω Without HART load ≤ 500 Ω

Proper installation should prevent water and dirt from entering the unit via the wires or conduit.

The device is provided with 4 wires for use. The table below shows the wire colour definitions:

**Wiring Colour Definitions**

Wire colour	Definition
Red	24 VDC [DC +]
Yellow	4-20 mA Source [SIG]
White	0 VDC [DC -]
Green/Yellow	Earth Ground

Use a maximum [Line + Load] resistance of 500 Ohm between the DC- [white] and 4-20 mA source [yellow] wires.

An external power source is required. Use a high quality, DC power supply with low noise characteristics. See the diagram below for power supply and wiring details:

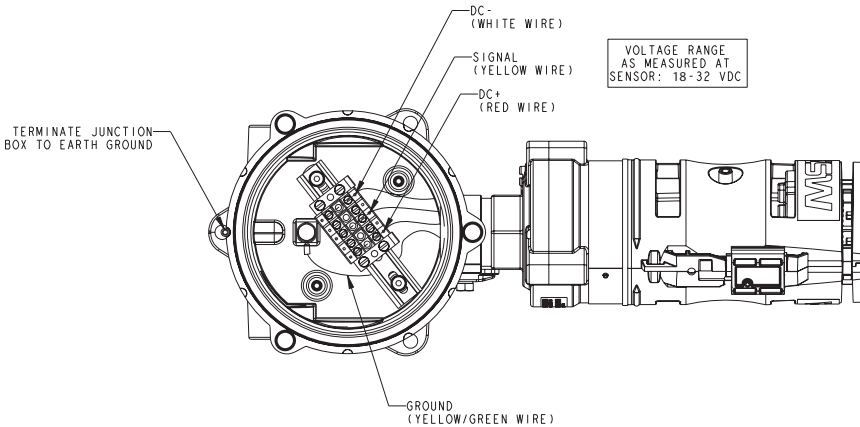

Fig. 7 Sensor Wiring Diagram



**Attention!**

Before wiring the device, disconnect or isolate all power connected to the device; otherwise electric shock could occur.

Power requirements		
Input voltage [at sensor]	Nominal	Maximum
18 V DC	220 mA	350 mA
24 V DC	175 mA	250 mA
32 V DC	130 mA	200 mA

### External Controllers

The device can be connected to any device capable of accepting a 4 - 20 mA sourcing analogue signal. Ensure that your controller can read all signals. Check the MSA website [www.MSAsafety.com](http://www.MSAsafety.com) for available controllers.

The HART output is intended to be used with digital control systems that are compatible with HCF Revision 7.0 protocol.

## 4 Start-up and Calibration

### 4.1 Initial Startup

The device is factory-calibrated and ready for use. The device provides a 4 - 20 mA output signal that can be used in conjunction with data acquisition controllers. The digital HART signal that is superimposed on the 4 - 20 mA output can be read by control systems that are in compliance with HART Revision 7.0 format.

During device operation, the 4 - 20 mA output signal is updated once/second and provides the information shown below:

<b>4-20 mA Output Levels [Default Values]</b>		
<b>OPERATION</b>	<b>4 - 20 mA</b>	<b>Definition</b>
SAFETY CRITICAL FAULT	0.0 mA	Sensor failure. Communications not available to sensor
*FAULT	2.0 mA	Problem detected. Status available via HART interface
*OBSCURATION OR DIRTY OPTICS	2.5 mA	Light path is blocked
*POWER UP OR SENSOR CALIBRATION	3.0 mA	Unit power was recently applied or calibration in process with Cal Signal Enabled
*CLEANING MODE	3.5 mA	Defined in chapter 5
NORMAL	Gas value scaled from 4 - 20 mA for 0 - 100 % LEL	
OVERRANGE	20.0 - 20.5 mA	>100% LEL gas is detected by the device

\*Output levels are customer configurable between 2.0 – 3.5 mA via the HART interface.

See the Hart Specification on the product CD for more information.

Transient Fault conditions will be automatically cleared when the unit recovers from the fault condition.

MSA recommends verifying proper response to changes in mA outputs by using the "Enter Fixed Current Mode" command described in the PrimaX IR Link Help Guide to check the four fault conditions noted with a \* above. These checks should be done at every calibration phase.

## Calibrations

### General

The calibration must be done at regular intervals in accordance with applicable national and regional regulations.

The device is calibrated at the factory. Nevertheless, it is recommended to re-calibrate the device after installation. New sensors should be calibrated more often until the calibration records prove sensor stability. The calibration frequency can then be reduced to the schedule set by the safety officer or plant manager.

### Signal

The 4 - 20 analogue signal is available within 1 minute of power-on but the device should be powered for at least 60 minutes before attempting calibration to allow for temperature stabilization.



Carry out the calibration during commissioning as well as at regular intervals. This ensures optimum operation of the sensor.

---



It is recommended that all calibration components are connected before starting a calibration as it is necessary to apply test gas at the appropriate time as shown in fig. 14.

---

Although the device is factory-calibrated, it is good practice to calibrate the unit once it is installed in its final environmental destination.

As with any type of gas monitor, the only true check of its performance is to apply gas directly to the sensor. New sensors should be calibrated more often until the calibration records prove sensor stability. The calibration frequency can then be reduced to the schedule set by the safety officer or plant manager.

Span gas selections are shown in chapter 4.3.

- (1) Read all calibration instructions before attempting an actual calibration.
- (2) Identify and become familiar with all of the calibration components.
  - ▷ Prior connection of the calibration components will make it easier to calibrate the unit.



### Attention!

Failure to follow the above can result in inaccurate calibration.

## 4.2 PrimaX IR Calibration

The device can be calibrated using either the optional calibration cap locally at the sensor, or using the HART digital interface.



MSA recommends using a calibration gas value in the middle of the measuring range for optimum calibration.

---

### Calibration methods



Fig. 8 MSA Calibration Cap



Fig. 9 HART Hand-held



Fig. 10 HART control system

Although both a full calibration [zero and span] and zero only calibration can be performed on the device, a zero only calibration may be sufficient to properly calibrate the monitor. Normally, any degradation of the sensor's performance is associated with slight drifts in zero that, in turn, will adversely affect its span performance. After completing the zero calibration, perform a span check to ensure proper operation. For a span check, apply a gas of known concentration and verify that the measured response is within acceptable limits. If the span check is unsuccessful, perform a full zero and span calibration.

The user may change the gas monitor's span value (1-100 %LEL), gas name and gas curve through use of the PrimaX IR Link software found on the product CD. Please refer to the PrimaX IR HART Specification and the PrimaX IR Link Help Guide on the product CD.

### Alternate Span Gas Settings

To achieve the most accurate calibration it is always best to use the gas of interest and calibrate at the operating temperature. If the target span gas is not available, an alternative span gas can be used with the values shown in the table below. The sensor label will identify the span gas and value used by the factory for calibration. Use of an alternate span gas for calibration may decrease accuracy.

## Calibration Settings

Target Gas	Range %LEL	ATEX performance certified		Calibration Gas	Span Value %LEL	t50	t90	Gas Curve Number
Methane	0-100	Yes	2.5%v/v	Methane	57	≤ 12 s	≤ 22 s	1
Propane	0-100	Yes	0.6%v/v	Propane	35	≤ 10 s	≤ 25 s	2
Toluene	0-50	Yes	2.5%v/v	Methane	57	≤ 11 s	≤ 28 s	3
n-Butane	0-100	Yes	0.6%v/v	Propane	37	≤ 10 s	≤ 24 s	2
n-Pentane	0-100	Yes	0.55%v/v	n-Pentane	50	≤ 11 s	≤ 24 s	2
n-Hexane	0-100	Yes	0.5%v/v	n-Hexane	50	≤ 11 s	≤ 24 s	2
Propylene	0-100	Yes	1.0%v/v	Propylene	50	≤ 11 s	≤ 25 s	3
Ethane	0-100	Yes	1.2%v/v	Ethane	50	≤ 11 s	≤ 23 s	3
Propylene Oxide	0-100	Yes	2.5%v/v	Methane	19	≤ 11 s	≤ 25 s	3
Acetone	0-100	Yes	2.5%v/v	Methane	44	≤ 11 s	≤ 25 s	2
Cyclopentane	0-100	Yes	0.6%v/v	Propane	35	≤ 10 s	≤ 25 s	2
Ethyl Acetate	0-70	Yes	2.5%v/v	Methane	21	≤ 12 s	≤ 25 s	2
IsoButane	0-100	Yes	0.65%v/v	IsoButane	50	≤ 12 s	≤ 26 s	2
Ethylene	0-100	No	1.35%v/v	Ethylene	50	≤ 10 s	≤ 23 s	3
Xylene	0-100	NO	1.35%v/v	Ethylene	19	≤ 10 s	≤ 25 s	3

**1** Response time t50 and t90 with HART calibration cover, gas flow rate 1.5 l/min

**2** IEC 60079-20-1 was used as bases for converting test and calibration gas concentrations from % LEL to % volume fraction

**3** For the measurement of n-Pentane, n-Hexane, Propylene, Ethane or Isobutane PrimaX IR shall be calibrated with the target gas at a span value of approximately 50 % LEL.



### Calibration Cap Procedure

- (1) Remove the environmental guard from the device.
- (2) The calibration cap is equipped with a slot for an optional tether retention system. The figure below shows the location of the tether slot.



Fig. 11 Calibration cap

1 Tether slot

- (3) If the user can confirm that the ambient air is free of combustible gas, ambient air can be used in place of the zero gas cylinder. See fig. 14 for a visual representation of the calibration process.
- (4) Install the calibration cap. Press firmly to ensure cap is properly seated.
  - ▷ The calibration process will start automatically when the cap is fully seated on the sensor housing.
  - ▷ Under normal conditions, the display will show all icons steady at power-up.
- (5) The calibration cap display indicates the zero gas cylinder symbol and flashes, indicating that the device is in Zero Calibration mode.
  - ▷ The initial 30 seconds is intended to give the user time to apply gas to the sensor. During this time, the user can abort the process by removing the calibration cap.
  - ▷ After the initial 30 seconds, the device will start the Zero calibration adjustment. The Zero Calibration is indicated by the white cylinder [→ fig. 12] and the word "Zero".

- ▷ Removal of the calibration cap after the initial 30 seconds will result in a calibration fault. This will abort the present calibration and the device will continue to operate with the previous calibration settings.
- (6) Apply zero gas to the calibration port at an approximate flow rate of 1.5 LPM while the cylinder symbol is flashing. Zero gas can be supplied as ambient air or from the zero gas cylinder in the calibration kit as noted in chapter 4.3.



Fig. 12 Zero Gas Cylinder Symbol

- (7) When the Zero calibration is successful, the tick symbol “✓” will appear. If only performing a Zero calibration, remove the calibration cap. Following a successful zero, the span process will automatically begin within 30 seconds following the zero symbol “✓”.
- (8) If the Zero calibration fails, the display will show an X for approximately 2 minutes, and will then power down.
- ▷ If the Zero calibration fails, remove the calibration cap and reinstall to start another zero attempt. If multiple failures occur, contact an authorized MSA service centre.
- (9) When the display flashes the span gas symbol, apply the span gas through the calibration cap port [→ figure 11].
- ▷ The unit must see gas within 30 seconds after the span symbol starts to flash or a calibration fault may occur. The initial 30 seconds are intended to give the user time to apply gas to the sensor. During this time, the user can abort the Span process by removing the calibration cap.
  - ▷ The display will then flash at a faster rate to indicate active calibration by the sensor.



Fig. 13 Span Gas Cylinder Symbol

- (10) When the Span calibration is successful, the tick symbol “✓” will appear. If the Span calibration fails, an X will be displayed for approximately 2 minutes, and the device will then power down.
- ▷ See chapter 5 for subsequent action upon calibration failure.

- (11) When calibration is complete, stop the gas flow and remove the calibration cap. Reconnect the environmental guard or flow cap to the sensor. The calibration cap will automatically power down once removed from the sensor. The 4-20 mA is held at the sensor calibration level for two minutes to reduce the chance of a nuisance alarm upon completion of a calibration procedure.
- ▷ During calibration and this 2 minute period, the unit will not be detecting any gas in the ambient area.
  - Alternately, the device can be commanded via HART to track the gas level during calibration [see the Calibration Signal Enable/Disable command in the HART Specification].
    - ▷ Once the calibration cap is removed it can take up to two minutes for gas to diffuse and the device to read normal ambient levels.

Steps 5-11 are shown in the figure below:

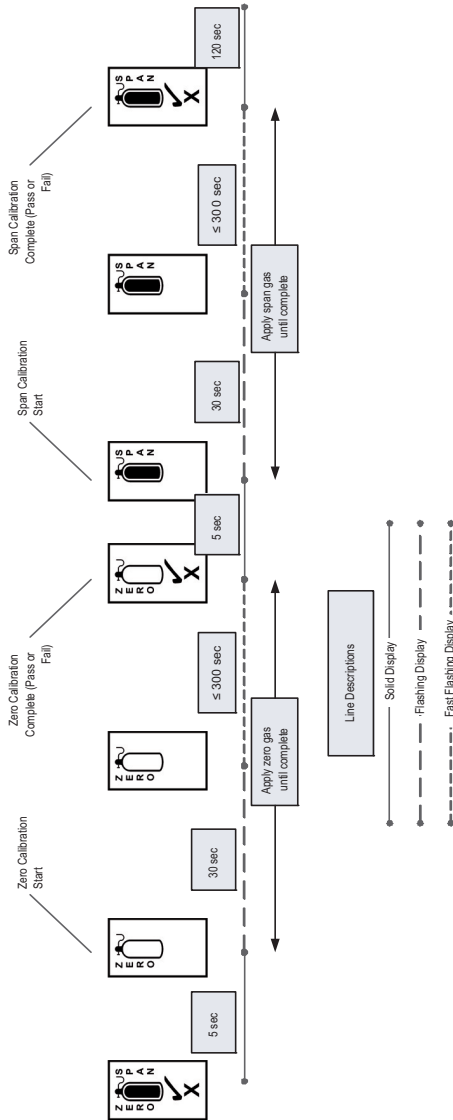

Fig. 14 Calibration Cap Sequence of Events

When a Zero or Span calibration failure occurs, the device reverts back to its previous successful calibration settings.

If the calibration cap is left on for more than 15 minutes after calibration concludes, the 4 to 20 mA signal indicates Fault status.

When the calibration cap battery is nearing the end of its useful life, the LCD will display all the icons in a series of rapid flashes at power-up before it starts the normal calibration cycle. The battery is non-serviceable and the calibration cap would need to be replaced once the battery is depleted.

**Attention!**

The calibration cap must be removed from the device after completing the Zeroing and/or Spanning procedure; otherwise, the sensor cannot perform properly.

**HART Calibration Procedure**

The device can be calibrated using a HART compatible communications interface with Device Description capability [DD], such as the Emerson 375 or 475 Field Communicator [→ fig. 9]. Ensure that the HART hand-held communicator is compatible with the area classification. This hand-held HART communicator must be HART revision 7.0 compliant and can be obtained from a HART authorised supplier. See the PrimaX IR HART specification found on the product CD for the calibration command definitions or visit the MSA website at [www.MSA.com](http://www.MSA.com).

Calibration can also be performed via the HART interface with optional screen inserts in the Environmental Guard. As shown in figure 15, the environmental guard can be fitted with these screens that will allow the calibration gas to be retained in the enclosure long enough for a valid zero and/or span reading to be obtained under still-air conditions of less than 1 m/s.

**Attention!**

Use of these inserts will increase the sensor response time to ambient gas conditions up to 210 seconds. Ensure that the operational conditions are appropriate for use of these screens.

When supplying tubing to the environmental guard to allow remote HART calibration, gas should be delivered to both ports of the environmental guard from a 1.5 l/min regulator as shown in figure 15:



Fig. 15 HART calibration set-up

#### 1 Screens

When used under windy conditions  $>1$  m/s, a calibration cover must be used instead of the environmental guard while applying the zero and span gas. Gas should be applied at 1.5 l/min. See figure 16 for a picture of the calibration cover.



Fig. 16 HART Calibration Cover

**Attention!**

Ensure that the calibration cover is removed after calibration is complete. This cover is intended to block the flow of ambient air into the sensor during calibration, and in normal operation must ALWAYS be removed

For applications where access to the HART signal is needed in hazardous areas, MSA provides the HART Module as shown in Fig. 17



Fig. 17 HART module

The explosion-proof port allows access via a HART hand-held controller using the cable shown above [part number 10081441].

### 4.3 Calibration Kits

Calibration kits are available for the device. The recommended calibration kits are shown in the following table.

GAS TYPE	CAL CYLINDER	CYLINDER P/N	SPAN VALUE	100%LEL to %vol *	CAL KIT #
Methane	2.5% Methane	10028032	57% LEL	4.4%vol	40
Propane	0.6% Propane	10028034	35% LEL	1.7%vol	40
Zero Gas	100% Nitrogen	10028030	0% LEL		40

\* Conversion defined by IEC60079-20-1:2012

See the PrimaX IR section of [www.MSAafety.com](http://www.MSAafety.com) for additional PrimaX IR calibration gases.

## 5 Maintenance

### 5.1 General



#### **Danger!**

Before working on the device, turn off the power and secure against re-start.

There are NO field repairable internal components for this device. Do not attempt to open the enclosure of the device, it is factory sealed for protection from hazardous environments. If the troubleshooting guides in chapters 5.2 and 5.3 do not alleviate the problem, contact your MSA representative.

### 5.2 Troubleshooting

The 4-20 mA output provides a limited set of information for diagnostic purposes. Additional troubleshooting steps are outlined below.

#### **General Troubleshooting Guide**

<b>Indication</b>	<b>Action</b>
Sensor IR source does not flash	Verify sensor and facility wiring according to the installation section and then reapply power
Sensor IR source is flashing but no 4-20 mA signal.	Verify sensor and facility wiring according to the installation section and then reapply power.
FAULT mA output	Check power supply and restart. Check to ensure that the calibration cap was not left on the sensor for an extended time. If an Underrange error is indicated via the HART interface, perform a zero calibration.
OBSCURATION mA output	Verify optical path is not obscured or perform the cleaning procedure below.
Elevated gas reading when no gas is expected to be present	Clean the optical window and mirror using the cleaning procedure below. Apply zero gas to see if reading drops to zero. If it does not, then perform Zero and Span calibration.



---

**General Troubleshooting Guide**

---

<b>Indication</b>	<b>Action</b>
Unstable 4 mA signal after power on and warm up	<p>Verify DC voltage supply is between 18 - 32 VDC. Total voltage, including any AC components, must be less than 32 VDC.</p> <p>If power supply is within 18-32 VDC, check for noise on the input power line. Use of an external filter may be required in this case.</p>
mA output current does not change when gas is applied	<p>Verify that gas flow path is unobstructed. Visually inspect the gas inlets and the regulator.</p> <p>Verify that you are not in calibration mode or any of the defined mA output levels shown in chapter 4.1.</p> <p>Verify that the device is not in Fixed Current Mode [Commanded via HART].</p>
Calibration cap span fails.	<p>Pull the cap off and evacuate gas from the calibration cap. Retry the calibration procedure and verify the Zero calibration was successful. If Zero calibration returns “✓” and the Span calibration fails, verify adequate span gas and flow. Verify that the Span gas is applied within the 30 second window.</p> <p>Check the o-ring integrity to ensure a good seal between the sensor and the calibration cap.</p> <p>Check the cap for damage.</p>
Calibration cap rapidly flashes all icons during startup	<p>The calibration cap battery is nearing the end of its useful life. The calibration cap will continue to operate until the battery is consumed.</p>
Known gas concentration response is incorrect	<p>Calibrate. If calibration fails, remove power and reapply.</p> <p>Verify span gas flow rate and cylinder accuracy. Verify environmental guard and/or flow cap are not obstructed.</p> <p>Verify line load is according to electrical installation chapter 3.2.</p> <p>Verify ambient temperature range is appropriate for the device rating.</p>
One source not flashing	<p>The PrimaX IR is designed to meet all specifications with only one source. Source status is available through HART communication. See HART manual for details.</p> <p>Perform standard calibration.</p> <p>No further action required.</p>

---

### 5.3 HART Information for Troubleshooting

The HART digital signal can provide additional information on the unit's health and status. Some of the information includes specific fault, calibration and obscuration status.

All available status bytes are defined in the PrimaX IR HART Specification found on the product CD. Refer to this document for complete HART command and status definitions. Use the HART digital interface to query the unit to provide additional troubleshooting information.

### 5.4 Cleaning

The presence of particulate matter, oil films, liquid water, or the residue from water drops on the device optics can adversely affect its performance. The environmental guard is designed to prevent solids or liquids from reaching the monitor's optical system. Heating elements are also incorporated into the unit to prevent water condensation. Under severe conditions, however, some material may collect on these surfaces and it may be necessary to occasionally check and clean the windows.

- (1) Remove the environmental or flow cap.



*Fig. 18 Remove Environmental Guard*

- (2) Place an opaque object [piece of paper, two fingers, etc.] between the light source window and the mirror to completely obscure the light path for two to three seconds [→ fig. 19].
  - ▷ If the opaque object is left in the light path for longer than 10 seconds, an Obscuration fault will be set on the mA output [→ chapter 4.1].
  - ▷ The device enters the Cleaning Mode for 5 minutes.



Fig. 19 Light path obscuration



The sensor will not respond to the presence of gas in cleaning mode.

- The analogue current output will be set to the the Cleaning Mode value [→ chapter 4.1] during this time.
- If monitoring the HART signal, the Cleaning Status bit will be set.

Although both windows are made of a highly durable material that is not easily scratched, avoid excessive pressure when cleaning them. Clean, cotton tipped applicators are recommended to remove material collected on the windows.

- (3) Use a dry applicator or one moistened with distilled water to wipe the window and remove dust.
- (4) Use an additional clean, dry applicator to remove any residual water.
- (5) Use an applicator moistened with isopropyl alcohol to remove heavy deposits of solids, liquids or oil films. Clean the window again with a second applicator moistened with distilled water; then, dry the window with a final applicator.
- (6) Avoid using excessive amounts of water or alcohol in the cleaning procedure, and inspect the window to ensure that the entire surface is clean.



When the cleaning process is complete, be sure to remove all objects from the light path.

When exiting the Cleaning Mode, the unit returns to normal operation. Note that residual cleaning fluids may result in an elevated signal until completely dry.

- (7) Inspect the environmental guard for any blockages, then replace the environmental guard on sensor.
  - ▷ After cleaning the windows, it is advisable to check the sensor's response to both zero and calibration gas.



### **Warning!**

Do not place foreign objects in the sensor's analytical region [except per the Cleaning Procedure above]; otherwise, the infrared beam can be partially blocked, causing the sensor to generate false readings. All objects must be removed from the sensor's analytical region for it to function properly.



### **Danger!**

If water or isopropyl alcohol is used to clean the sensor's windows, any residue from the cleaning procedure must be completely dissipated before returning the unit to service. Checking the sensor's response to zero gas is the best way to purge residual cleaning materials from the sensor. Ensure that the sensor's reading is stable before zeroing or calibrating the sensor [→ chapter 4].

## **5.5 Environmental Guard Cleaning**

It is good maintenance practice to occasionally clean the environmental guard by removing it and rinsing it with water, or using compressed air to clean it [→ fig. 20]. Always reinstall the environmental guard for normal operations to provide protection against damage to the mirror and windows, and to help prevent dust from accumulating on the optical surfaces.



Fig. 20 Environmental Guard Cleaning

## 5.6 Calibration Cap Cleaning Procedure

In general, the calibration cap should not require any maintenance. However, if it is used in extremely dirty or solvent based environments, it may be necessary to clean the light sensor if the calibration cap performance is not adequate.

- Use a clean, dry applicator and isopropyl alcohol to gently swab the light sensor, as shown in figure 21.



### Attention!

Never immerse the calibration cap in water or damage will occur.



Fig. 21 Calibration cap diode cleaning

## 6 Technical Data

MEASURING RANGE		0-100% LEL
OPERATING TEMPERATURE RANGE	Sensor	-50 to +80° C [-58 to +176° F]
	Calibration Cap	-30 to +60° C [-22 to +140° F]
STORAGE TEMPERATURE RANGE	Sensor	-40 to +80° C [-40 to +176° F]
DRIFT	Zero Drift	<1%LEL/ 3 months
	Span Drift	<2%LEL/ 3 months
NOISE		<1% FS
STEP CHANGE RESPONSE	t50 with Environmental Guard	<10 sec
	t90 with Environmental Guard	<25 sec Methane <20 sec Propane
HUMIDITY		15 to 95% RH, non-condensing
PRESSURE		600 - 900 mmHg (80 - 120 kPa)
SENSOR LIFE	→ chapter 1.4	
IN-RUSH CURRENT		<350 mA
POWER INPUT		18 – 32 VDC including any AC components
POWER CONSUMPTION		< 6.0 W
SIGNAL OUTPUT	4-20 mA	3-wire current source
PHYSICAL CHARACTERISTICS	LENGTH	203 mm
	WEIGHT	1.5 kg
	MATERIAL TYPE	316 Stainless Steel
INGRESS PROTECTION		IP67 [3rd party certified]

## 7 Accessories

The following accessories are available for the device:

Description	Part No.	
Calibration cap	10111874	Figure 1
Aluminum junction box kit (Includes mounting bracket)	10117607 – NPT 10117606 – M25	Figure 1
316 stainless steel junction box kit (Includes mounting bracket)	10117608 – NPT 10117609 – M25	Figure 1
Insect screen/Remote calibration inserts	10116419	Chapter 7.5
Sun shield	10113481	Chapter 7.2
HART calibration cover / Bump Cap	10122228	Figure 16
HART hand-held communicator cable	10081441	Figure 17
Flow cap	10113100	Chapter 7.1
3-way pushbutton valve	635729	Chapter 7.1
Sensor O-ring	10105967	
Environmental guard	10113663	Figure 1
Stainless steel tether	10114097	Figure 1
Duct mount flange	10114373	Chapter 7.3
HART Junction Box	10119594 - M25 10119593 - NPT	Chapter 7.4

### 7.1 Flow Cap



Fig. 22 Flow cap

The flow cap is for use with a sampling system. It is available in 316 stainless steel and is secured to the sensor in place of the environmental guard with two screws.

A 3-way pushbutton valve is available for ease of calibration when using the flow cap. The sample flow and the calibration gas can both be plumbed to this valve, and the operator holds down the pushbutton to switch the flow to the calibration gas.

Use a gas flow rate of 1.5 l/min when using the flow cap to achieve the response times stated in chapter 6.



Using the flow through adapter can extend the response time, depending on the gas flow rate and system design.

---

## 7.2 Sunshield

The sunshield is a 316 stainless steel plate that protects the sensor from direct sunlight and from excessive temperature rise.



*Fig. 23 Sun shield*

## 7.3 Duct Mount Flange

Gas monitoring in air ducts can be performed by means of this duct mount flange.

Install the sensor in a location that is convenient for maintenance, where it will be exposed to a representative sample and is not subject to extremes of flow, turbulence, temperature and particulate.

When installing, the direction of flow inside the duct must be as shown in Fig. 24.

Calibration of the device mounted in an air duct must be done with the HART interface. Once calibration has been initiated, apply the calibration gasses via the gas calibration port. Ensure that the duct is free of all gases to which the sensor will respond and the duct flow rate is below 1 m/s. If hydrocarbon combustible gas is present in the duct, the sensor must be removed from the duct during calibration. The sensor can be removed from the duct mount bracket via four screws.



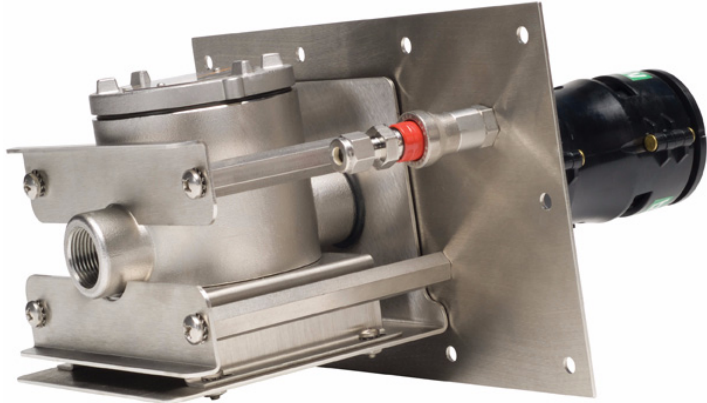

Fig. 24 Duct mount

1 Flow

2 Gas calibration port

## 7.4 HART Module

The HART Module is a 316 Stainless Steel enclosure that provides a hazardous area approved HART port for access to the HART signal. The PrimaX IR can be mounted to this module using an available port and all applicable facility wiring rules from Section apply to wiring the HART Module.



Fig. 25 HART module

An optional cable is available from MSA to connect to the XP HART port from a hand-held controller.

## 7.5 Insect Guard/Remote Calibration Inserts

For applications where HART is being used for calibration and the sensor is located in a remote location where use of the calibration cover is not practical, optional screen inserts are available. These inserts snap into the environmental guard [→ fig. 26] and permit a very slow diffusion of gas through the tight mesh screens. This allows enough zero and span gas to be retained in the environmental guard for the calibration procedure to be accurate for still air applications.



### Attention!

Use of these inserts will increase the sensor response time to ambient gas conditions up to 210 seconds. Ensure that the operational conditions are appropriate for use of these screens.

These screens can be used as an insect guard.



Fig. 26 Remote cal/ Insect screen inserts

## 8 Approvals

### 8.1 Marking, Certificates and Approvals According to the Directive 94/9/EC ATEX

#### Prima X IR

Manufacturer:	Mine Safety Appliances Company 1000 Cranberry Woods Drive Cranberry Township, PA 16066 USA
Product:	PrimaX IR
Type of protection	EN 60079-0:2009, EN 60079-1:2007 IEC 60079-31:2009
Measuring function for explosion protection:	EN 60079-29-1:2007, EN 50271:2010
Gas:	<b>measure range: 0-100% LEL</b> Methane, Propane, n-Butane, n-Pentane, n-Hexane, Propylene Ethane, Propylene Oxide, Acetone, Cyclopentane, Ethyl Acetate <b>measure range: 0-50% LEL</b> Toluene <b>measure range: 0-70% LEL</b> IsoButane
Marking:	PrimaX IR  II 2 G Ex d IIC T4 Gb II 2 D Ex tb IIIC T130°C Db IP67 -50°C ≤ Ta ≤ +80°C
EC-Type Examination Certificate:	BVS 10 ATEX E 157 X
Quality Assurance Notification :	0080
Year of Manufacture: :	see Label
Serial Nr.: :	see Label
EMC Conformance according to the Directive 2004/108/EC	EN 50 270:2006 Type 2 EC 61 000-6-4:2007

**Special conditions for safe use:**

- For dust applications the installation conditions according to EN 61241-14 has to be considered. Take precaution to avoid electrostatic discharge with respect to the instrument label.
- Maintenance or repair for protection "d" equipment is only allowed by the manufacturer.
- The gas monitor PrimaX IR is equipped with a tapered NPT  $\frac{3}{4}$ " thread or a metric M25 x 1,5 thread for mounting to a connection enclosure of protection type increased safety "e" or protection type flameproof enclosure "d".
- When mounting the gas monitor to an enclosure of protection type flameproof enclosure "d" the reference pressure of the separate enclosure for the connection must not exceed 10,5 bar. The test of the mechanical strength of the separate enclosure for the connection and the test of the connecting thread with respect to explosion hazards must be ensured within the framework of the type test of the electrical apparatus, that is attached to the gas monitor PrimaX IR. The threaded hole to which the gas monitor is attached to must meet the requirements of section 5.3 [Table 3/4] of EN 60079-1.
- NPT  $\frac{3}{4}$ " fixture has to be sealed with 2 layer PTFE sealing tape or according to the instructions of the manufacturer of the enclosure with NPT thread; when removed, new PTFE sealing has to be used after reinstalling.
- When mounting the gas monitor to protection "e" [increased safety] enclosures, the mechanical resistance and the IP protection [IP6X] of the mounted enclosure has to be ensured by the type test of the electrical apparatus being mounted to the gas monitor. After mounting of the gas monitor onto a protection "e" enclosure, the clearances and creepage distances must meet the requirements of 4.3 [Table 1] of EN 60079-7. The non-shielded cables of the gas monitor must be routed and connected so as to be mechanically protected and corresponding to the temperature resistance of the cables as per 4.2, 4.5.1 and 4.8 of EN 60079-7.
- The PrimaX IR gas monitor must be screwed into the housing wall such that it is secured against self-loosening. The specified minimum thread depth of the add-on housing has to be observed.
- The connection of the PrimaX IR Gas Monitor to a control device with a measurement function for explosion protection, is not part of the BVS 10 ATEX E 157X examination certificate.
- The screw heads are filled with potting to prevent self-loosening and unauthorized entry. Do not open enclosure. Opening the enclosure invalidates the type approval. The certification requires that the screws have a minimum yield stress of 600 N/mm<sup>2</sup>.

- Due to limitations on the potting used for the wire bushing on the PrimaX IR Gas Monitor, the service temperature within the separate enclosure (the enclosure to which the PrimaX IR is mounted) must not exceed 120°C.
- The PrimaX IR Gas Monitor must be included with the earthing and equipotential bonding of the complete system, including the enclosure to which it is connected.

### PrimaX IR Calibration Cap

Manufacturer: Mine Safety Appliances Company  
1000 Cranberry Woods Drive  
Cranberry Township, PA 16066 USA

Product: PrimaX IR Calibration Cap

Type of protection: EN 60079-0:2006, EN 60079-11:2007

Marking:



II 2 G Ex ia IIC T4  
-30°C ≤ Ta ≤ +60°C

EC-Type Examination Certificate: LCIE 10 ATEX 3090

Battery : Panasonic BR 1632A

Quality Assurance Notification : 0080

Year of Manufacture : see Label

Serial Nr. : see Label

EMC Conformance according to the Directive 2004/108/EC EN 61000-6-3:2007

### X Series Aluminium Junction Box

Product: X Series Aluminium Junction Box

Type of protection: EN 60079-0:2006, EN 60079-1:2007,  
EN 61241-0:2006, EN 61241-1:2004

Performance: no

Marking:



II 2 G Ex d IIC T4 -50°C ≤ Ta ≤ +80°C  
T6 -50°C ≤ Ta ≤ +40°C

II 2 D Ex tD A21 IP6x  
T135°C -50°C ≤ Ta ≤ +80°C  
T85°C -50°C ≤ Ta ≤ +40°C

EC-Type Examination Certificate: BVS 10 ATEX E 066X

Year of Manufacture : see Label

Serial Nr. : see Label

**X Series Junction Box**

Manufacturer: Mine Safety Appliances Company  
 1000 Cranberry Woods Drive  
 Cranberry Township, PA 16066 USA

Product: X Series Junction Box

Type of protection: EN/IEC 60079-0, EN/IEC 6079-1,  
 EN 61241-0, EN 61241-1

Marking:



II 2 G Ex d IIC  $-50^{\circ}\text{C} \leq \text{Ta} \leq +105^{\circ}\text{C}$  IP66  
 II 2 D Ex tD A21  $-50^{\circ}\text{C} \leq \text{Ta} \leq +105^{\circ}\text{C}$  IP66  
 IECEx: FMG07.0003U  
 IECEx: Ex d IIC IP66  
 $-40^{\circ}\text{C} \leq \text{Ta} \leq +105^{\circ}\text{C}$

IECEx-Type Examination Certificate:FM06ATEX0029U

Year of Manufacture : see Label  
 Serial Nr. : see Label

## 8.2 Marking, Certificates and Approvals According to IECEx

### PrimaX IR

Manufacturer:	Mine Safety Appliances Company 1000 Cranberry Woods Drive Cranberry Township, PA 16066 USA
Product:	PrimaX IR
Type of protection	IEC 60079-0:2007, IEC 60079-1:2007 IEC 60079-31:2009
Measuring function for explosion protection :	no
Gas:	see manual
Marking:	PrimaX IR  Ex d IIC T4 Gb Ex tb IIIC T130°C Db IP67 -50°C ≤ Ta ≤ +80°C IECEx BVS 10.0101 X
EC-Type Examination Certificate:	
Quality Assurance Notification :	0080
Year of Manufacture:	see Label
Serial Nr.:	see Label
EMC Conformance according to the Directive 2004/108/EC	EN 50270:2006 Type 2 IEC 61000-6-4:2007

### Special conditions for safe use:

- For dust applications the installation conditions according to EN 61241-14 has to be considered. Take precaution to avoid electrostatic discharge with respect to the instrument label.
- Maintenance or repair for protection "d" equipment is only allowed by the manufacturer.
- The gas monitor PrimaX IR is equipped with a tapered NPT ¾" thread or a metric M25 x 1,5 thread for mounting to a connection enclosure of protection type increased safety "e" or protection type flameproof enclosure "d".
- In case of mounting the gas monitor to an enclosure of protection type flameproof enclosure "d" the reference pressure of the separate enclosure for the connection must not exceed 10,5 bar. The test of the mechanical strength of the separate enclosure for the connection and the test of the connecting thread with respect to explosion hazards must be ensured within the framework of the type test of the electrical apparatus, that is attached to the gas monitor PrimaX IR.

The threaded hole to which the gas monitor is attached to must meet the requirements of section 5.3 [Table 3/4] of EN 60079-1.

- NPT 3/4" fixture has to be sealed with 2 layer PTFE sealing tape or according to the instructions of the manufacturer of the enclosure with NPT thread; when removed, new PTFE sealing has to be used after reinstalling.
- When mounting the gas monitor to protection "e" [increased safety] enclosures, the mechanical resistance and the IP protection [IP6X] of the mounted enclosure has to be ensured by the type test of the electrical apparatus being mounted to the gas monitor. After mounting of the gas monitor onto a protection "e" enclosure, the clearances and creepage distances must meet the requirements of 4.3 [Table 1] of EN 60079-7. The non-shielded cables of the gas monitor must be routed and connected so as to be mechanically protected and corresponding to the temperature resistance of the cables as per 4.2, 4.5.1 and 4.8 of EN 60079-7.
- The PrimaX IR gas monitor must be screwed into the housing wall such that it is secured against self-loosening. The specified minimum thread depth of the add-on housing has to be observed.
- The PrimaX IR gas monitor and enclosure must both be earth grounded.



**PrimaX IR Calibration Cap**

Manufacturer:	Mine Safety Appliances Company 1000 Cranberry Woods Drive Cranberry Township, PA 16066 USA
Product:	PrimaX IR Calibration Cap
Type of protection	IEC 60079-0:2004, IEC 60079-11:2006
Marking:	 II 2 G Ex ia IIC T4 $-30^{\circ}\text{C} \leq T_a \leq +60^{\circ}\text{C}$
IECEX-Type Examination Certificate:	IECEX LCI 10.0038 X
Battery	Panasonic BR 1632A
Quality Assurance Notification :	0080
Year of Manufacture: :	see Label
Serial Nr.: :	see Label
EMC Conformance according to the Directive 2004/108/EC	EN 61000 - 6 - 3: 2007

### 8.3 Special conditions for the safe use according to ATEX and SIL applications

The PrimaX IR Gas Monitor has been subjected to rigorous reliability and functional safety assessments, which have culminated in the gas monitor being certified to IEC 61508, EN 50271 by TÜV Rheinland Industrie Service GmbH. The tables below list the SIL parameters for this device.

#### Safety relevant parameters for the PrimaX IR Gas Monitor:

Type	B
Structure	1oo1 or 1oo2
HFT	0 or 1
Safe Failure Fraction (SFF)	95%
DC	91%
$\lambda_S$ (Detected safe failure rate)	1154.7fit
$I_{DU}$ (Undetected dangerous failure rate)	104.1fit
$I_D$ (Dangerous failure rate)	1154.7fit
$I_{DD}$ (Detected dangerous failure rate)	1050.6fit
PFD, PFH	See table
MTTR	72 hr
TI (Test Interval)	See table
Ambient Temperature	40°C

	PFD <sub>1001</sub>	PFD <sub>1001</sub> % SIL2	PFD <sub>1002</sub>	PFD <sub>1002</sub> % SIL3	PFH <sub>1001</sub>	PFH <sub>1001</sub> % SIL1	PFH <sub>1002</sub>	PFH <sub>1002</sub> % SIL3
16weeks TI	$2.2 \times 10^{-4}$	2.2%	$1.1 \times 10^{-5}$	1.1%	$1 \times 10^{-71}/h$	1.04%	$5.2 \times 10^{-91}/h$	5.2%
52weeks TI	$5.4 \times 10^{-4}$	5.4%	$2.7 \times 10^{-5}$	2.7%	$1 \times 10^{-71}/h$	1.04%	$5.3 \times 10^{-91}/h$	5.3%

### Possible structures and acquirable SILs

The following table shows which structure has to be selected to fulfill the requirements of a specific SIL.

LDM = Low Demand Mode

HDM = High Demand or Continuous Mode

	SIL 1		SIL 2		SIL 3	
	LDM	HDM	LDM	HDM	LDM	HDM
<b>Structure 1oo1</b>	X	X	X			
<b>Structure 1oo2</b>	X	X	X	X	X	X

Depending on the selected configuration and the sensor version, the following safety-relevant parameters have to be considered while implementing the safety loop:

#### General conditions for safe use:

- The application advice and the limitations of the manual have to be considered. For calibration and maintenance, the regional and national regulations have to be considered.
- A defective device has to be repaired within 72 hours.
- The HART® interface cannot be used for the transmission of safety related data.
- The connected controller has to monitor the 4-20 mA signal current for values below 4 mA and above 20 mA.
- A functional check/calibration check has to be done for the complete system.
- A visual check has to be done together with the calibration.
- A system check has to be done every year.
- Calibration and adjustment are part of the function/calibration check.
- The test gas must be the gas to be monitored. The concentration of the test gas has to be in the middle of the measurement range.
- For zero gas, clean air, free of hydrocarbon combustible gas or synthetic air, has to be used.
- An adjustment has to be done under the following conditions:
  - difference at zero > +/- 5 % UEG (LEL)
  - difference at sensitivity > +/- 20 % of the rated value

- If the calibration is inside of the valid tolerance, the calibration interval can be doubled.
- The maximum of the calibration interval is 52 weeks.
- The gas monitor has to be replaced if the sensor sensitivity during the operation is reduced to less than 50% of the initial sensitivity.
- For the power supply a SELV/PELV version or the requirements of EN60950 and EN50178 has to be fulfilled.

**Special conditions for SIL 2**

- The use of the device in a High Demand or Continuous Mode is allowed only in a 1oo2 - structure.
- The 4-20 mA output of the device must be monitored regarding deviations.

**Special conditions for SIL 3**

- The use of the device is allowed only in a 1oo2 - structure.
- The 4-20 mA output of the device must be monitored regarding deviations.

