



# **Alarmline II Digital EN Controller**

## Installation Instructions

---

## Contents:

---

<b>Important Guidelines – read before commencing installation</b>	<b>Page 3</b>
<b>General Overview</b>	<b>Page 4</b>
<b>Technical Specifications</b>	<b>Page 5</b>
<b>Installation</b>	<b>Page 6</b>
- Overview	
- Connections Diagram	
<b>Operating Modes</b>	<b>Page 7</b>
- Wiring Diagram: Independent	
- Wiring Diagram: Interlock	
<b>Useful Information</b>	<b>Page 9</b>
- Leader Cable	
- Mounting Dimensions	
- Static Discharge Cautionary	
<b>Commissioning</b>	<b>Page 10</b>
- Normal Operation	
- Fault / Alarm Conditions	
<b>Testing and Verification</b>	<b>Page 14</b>
<b>Two-wire RS-485 Modbus RTU/ASCII Communications</b>	<b>Page 15</b>
<b>Resetting the AlarmLine II Digital EN Controller</b>	<b>Page 16</b>
<b>Glossary</b>	<b>Page 17</b>

## Important Guidelines

---

Please read this instruction leaflet thoroughly before commencing installation.

- ✓ Install the AlarmLine II Digital EN Controller accordingly to meet local and country installation requirements.
- ✓ The AlarmLine II Digital EN Controller must be installed in accordance with BS 5839-1:2017 (or country equivalent) and IEC 60364 and authorities having jurisdiction.
- ✓ Ensure the product is installed, commissioned and maintained by qualified professionals according to good engineering practices and who have received sufficient training on the unit.
- ✓ Only use Kidde AlarmLine II Digital EN Linear Heat Detection cable with the AlarmLine II Digital EN Controller.
- ✓ Test the Digital Linear Heat Detection cable before connecting it to the AlarmLine II Digital EN Controller using a multimeter.
- ✓ Ensure the end of line resistor (3.6kohm) is securely connected at the end each linear heat detection cable.
- ✓ If only one zone is required leave the end of line resistor (3.6kohm) connected across the terminals of the unused zone.
- ✓ Ensure any cable glands used are tightened to form a secure and moisture proof seal around the detection cable and any other cable in or out of the unit.



Do not exceed the maximum operating voltage of the AlarmLine II Digital EN Controller (36Vdc).



Do not connect lengths of linear heat detection cable in 'T' connections or spurs.

# General Overview

## AlarmLine II Digital EN Controller

The Kidde AlarmLine II Digital EN Controller is a dual zone module for monitoring up to two zones of Kidde AlarmLine II Digital EN Linear Heat Detection (LHD) Cable. If an overheat or fire situation triggers either zone of the Digital LHD cable the unit automatically calculates and displays the distance along the cable, in feet and metres, to the alarm point. The two zones can operate independently of each other, or in interlock mode and a separate alarm and normally conducting fault output are provided for

each zone. The unit is intended to be installed between the Digital Linear Heat Detection cable and a conventional or addressable fire alarm control panel. It has power, fault and alarm lights, as well as volt free outputs for fault and alarm, corresponding to each zone. It may also be connected to a industrial process control system using the two wire RS-485 Modbus RTU/ASCII output.

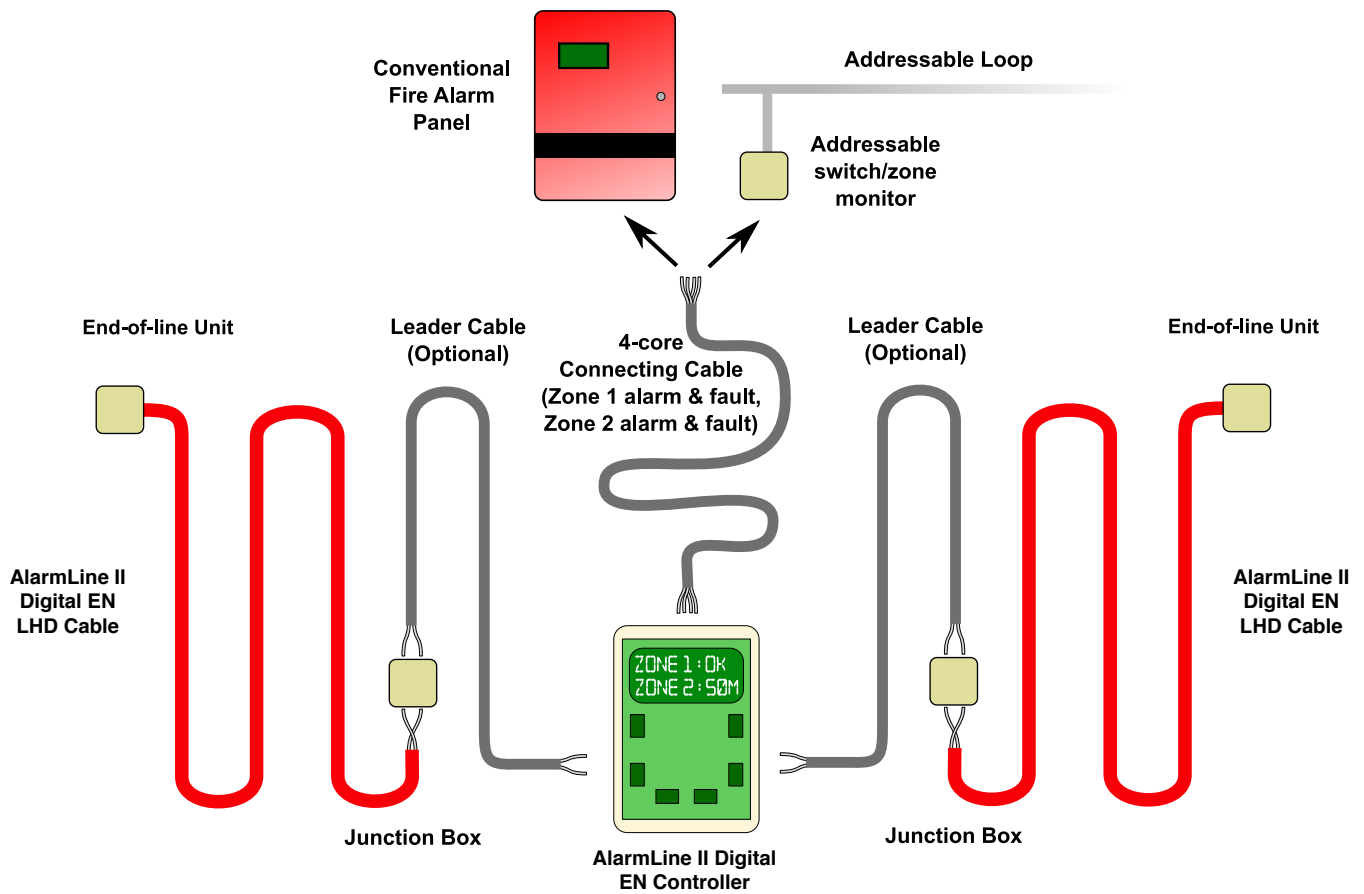

(Power supply & Modbus connections not shown)

Figure 1: Typical Installation of the AlarmLine II Digital EN Controller

## Technical Specifications

<b>Kidde Part Number:</b>	ADELCU-2
<b>Kidde Part Description:</b>	AlarmLine II Digital EN Controller
<b>UL Model Number:</b>	ADELCU-2
<b>UL File Number:</b>	S36421
<b>Revision:</b>	1.9.2-EN
<b>Approvals:</b>	EN54-28:2016
<b>Enclosure:</b>	
...Dimensions	H180mm x W120mm x D60.5mm (H7.1in x W4.72in x D2.38in)
...Rating	NEMA 4, 4X (IP65)
...Finish	Light Gray with clear lid
...Display	2 line, 16 character backlit display showing zone status
<b>Power Requirements:</b>	<i>All circuits power limited if powered from a power limited supply</i>
	Min.         Nominal         Max.
...Operating Voltage	12Vdc — 24Vdc — 36Vdc
<b>Current Consumption:</b>	↓                   ↓                   ↓
...Normal Operation (standby)	<15mA   <7mA   <5mA
...Alarm	<40mA   <23mA   <15mA
<b>Operating Temperature Range:</b>	-20°C – +50°C (-4°F – +122°F)
<b>Terminal Blocks:</b>	
...Spacing	5mm Rising Clamp
...Rating	16A
...Wire Size	0.08mm <sup>2</sup> (28AWG) to 4mm <sup>2</sup> (11AWG)
<b>Supervised Circuits:</b>	Power, Input Zone 1 & Input Zone 2
<b>Inputs:</b>	<i>Up to two Class B zones of Kidde AlarmLine II Digital EN LHD Cable</i>
...Max Zone Length	1000m (3,280ft)
...Min Zone Length	1m
...End of line resistor	3.6kohm (included)
...Short circuit current	0.5mA
...Max Zone Voltage	5V
<b>Outputs:</b>	
...Communications	Two wire RS-485 Modbus RTU/ASCII
...Sounder	2.4kHz 92dBa @ 10cm Buzzer
...Alarm	2x Form C volt-free relay contacts (resistive, common)
	<i>Max V</i> 30Vac or 42.4Vdc
	<i>Max Current</i> 2A
	<i>Max Switching Power</i> 60W, 62.5VA
...Fault	2x Optoisolated phototransistor output (resistive, common)
	<i>Max V</i> 35Vdc
	<i>Max Current</i> 80mA
	<i>Max Power Dissipation</i> 150mW

# Installation

## Overview

The AlarmLine II Digital EN Controller allows accurate location of an alarm point along a length of Kidde AlarmLine II Digital EN Linear Heat Detection (LHD) cable. It continuously monitors up to two zones of Digital LHD cable for a fault (open circuit) or an alarm (overheat or fire condition). Because of the wide range of applications that Digital LHD cable can be used for, it may not always be possible, or be too time consuming, to locate where along the cable an alarm has occurred. Using the AlarmLine II Digital EN Controller, when an alarm occurs the distance to the overheat condition is immediately calculated and displayed on the integrated display.

If a fault is detected, the corresponding fault output stops conducting, triggering a fault at the fire alarm control panel. If an alarm is detected, the corresponding alarm output changes state, triggering an alarm at the fire alarm panel. The fault outputs also stop conducting on power loss to the unit or microprocessor fault, triggering a fault at the fire alarm control panel.

The two wire RS-485 Modbus RTU/ASCII output also outputs the current state of both zones. See the section "Modbus RTU/ASCII Communications" for more detail.

There are two primary configurations of the AlarmLine II Digital EN Controller (see figure 1):

- 1) The Digital LHD cable can be connected directly to the AlarmLine II Digital EN Controller
- 2) The Digital LHD cable is connected to a length of leader cable which is connected to the AlarmLine II Digital EN Controller. In this scenario the leader cable must be "calibrated out" during commissioning of the AlarmLine II Digital EN Controller.

## Connections Diagram

Figure 3 shows the connections diagram for the AlarmLine II Digital EN Controller. The unit is provided with a 3.6kohm end of line resistor in each zone input. If only one zone is required, leave the 3.6kohm resistor connected across the zone which is not in use. Otherwise the 3.6kohm resistor should be connected at the end of the Digital Linear Heat Detection cable.

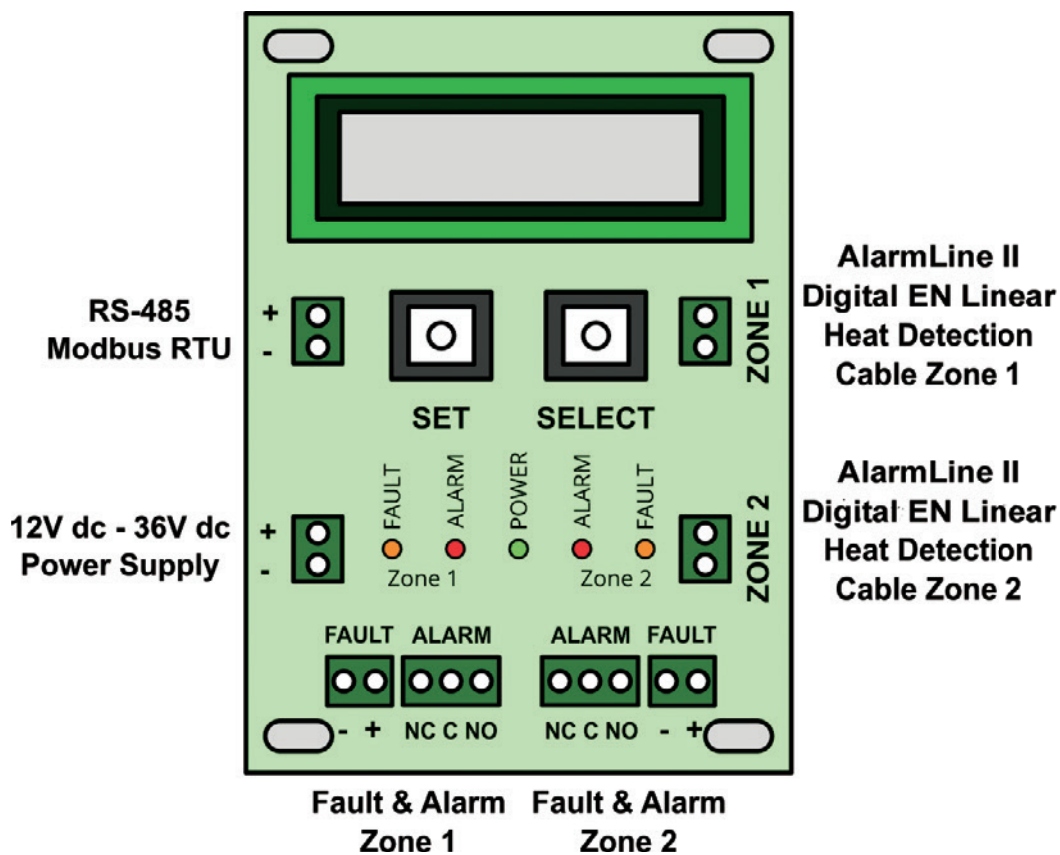
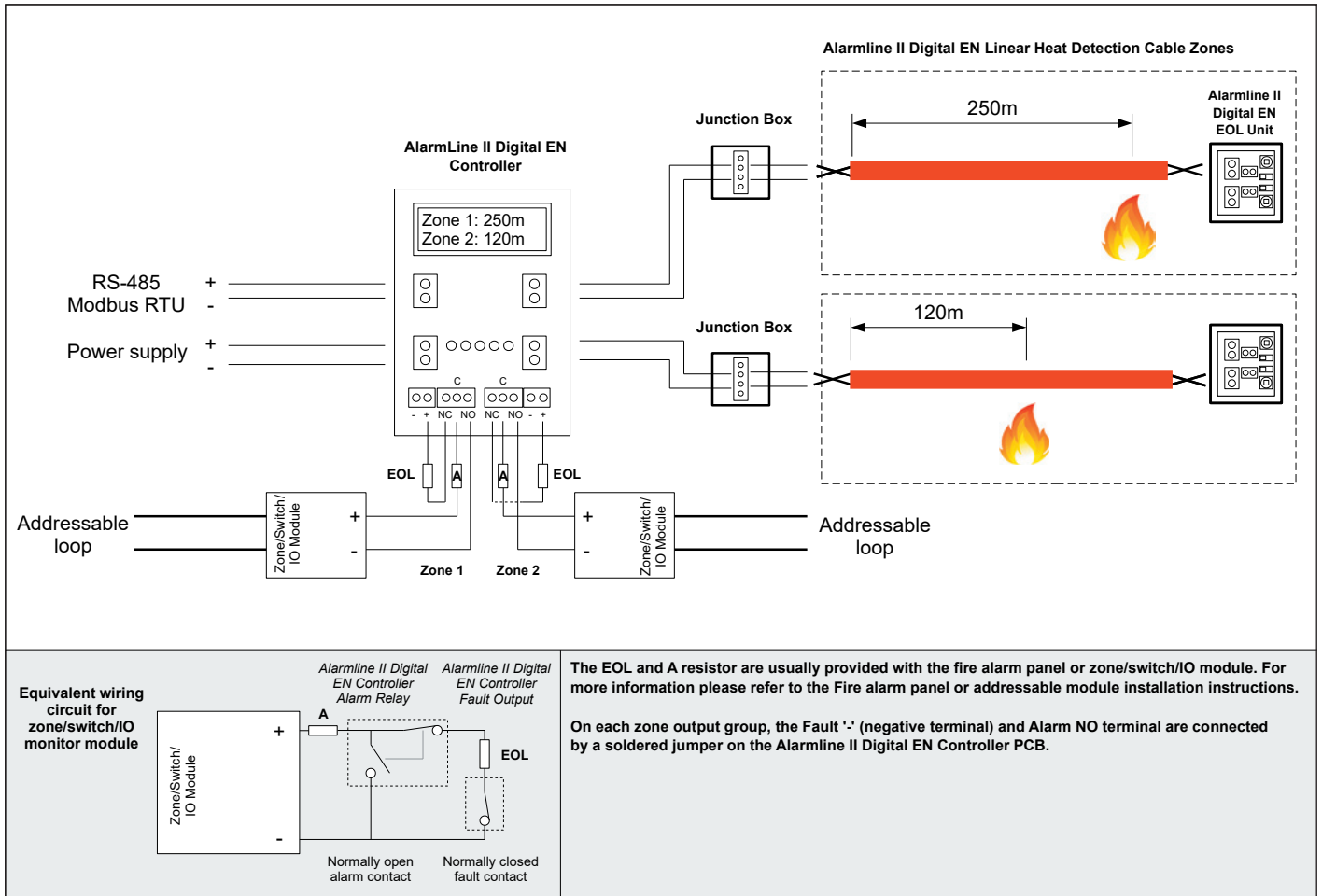

Figure 3: Wiring Diagram for the Kidde AlarmLine II Digital EN Controller

## Operating Modes Wiring Diagram Independent

There are two operating modes for the AlarmLine II Digital EN Controller:

1. **Independent** – This is when the AlarmLine II Digital EN Controller is used as a two zone system. When a fault or overheat condition occurs on a Digital LHD zone, the corresponding fault or alarm output respectively is triggered. The two zones operate independently and both sets of outputs should be connected to a fire alarm control panel. If the zone is not required leave the 3.6kohm resistor in the zone input terminals as supplied. In this mode, the two zones can either contain identical rated temperature Digital LHD cables or two different rated temperature Digital LHD cables.



## Operating Modes Wiring Diagram Interlock

2. **Interlock** – this mode is for applications which require a fail-safe guarantee that an alarm is only triggered when an overheat condition has been detected. This mode may also be known as coincidence detection. In this case, the same rated temperature Digital LHD cable should be attached to both zones of the AlarmLine II Digital EN Controller. The alarm output is only activated when both Digital LHD cables trigger an alarm due to an overheat condition. If one Digital LHD cable zone input registers an alarm but the second does not, the alarm output will **not** be activated. This is to prevent an alarm if a mechanical or other issue has triggered one Digital LHD cable and not an overheat condition.

- Only use Zone 1 fault and alarm outputs in Interlock mode.
- Two linear heat detection cables with the same temperature rating must be used and a minimum of two linear heat detection cables must be installed in each protected space.

See the AlarmLine II Digital EN LHD Installation Instructions for the linear spacing specification.

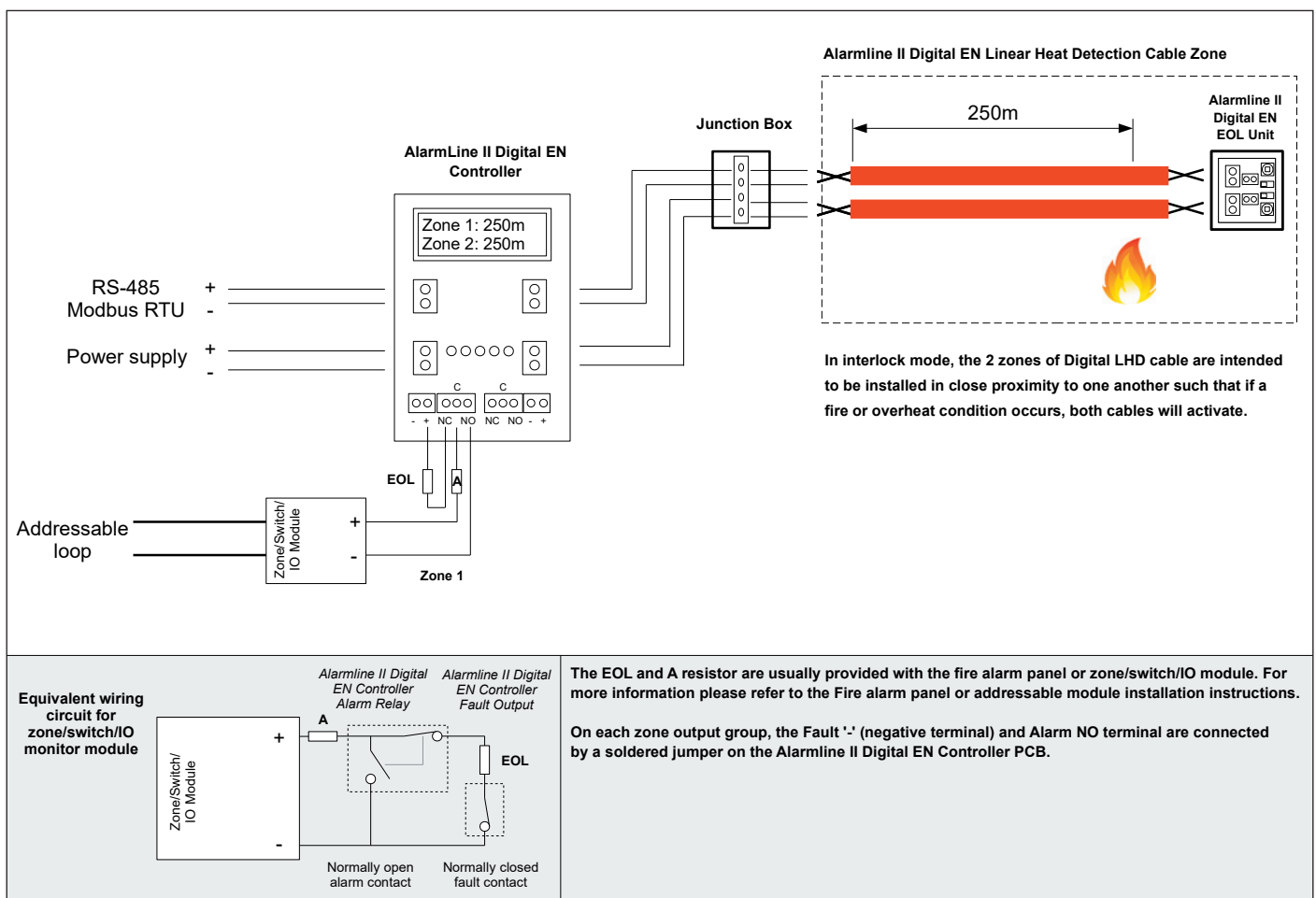



# Useful Information

## Leader Cable

In certain applications it may be desirable or necessary to use non-sensing leader cable between the AlarmLine II Digital EN Controller and the Digital LHD cable. For example, if the AlarmLine II Digital EN Controller is located some distance away from the area protected by the Digital LHD cable. This may be required if the expected ambient temperature range, or other environmental conditions, where the Digital LHD cable is to be used is greater than the maximum ambient temperature range for the AlarmLine II Digital EN Controller. (see steps 8, 9 and 10 in the Commissioning section on pages 10-11).

The maximum length of leader cable that can be used per zone is dependent upon the leader cable diameter'. The following is a guideline for typical cable sizes and maximum length:

Leader Cable Size	Max Leader Cable Length
20AWG (16x0.2mm or 0.8mm dia, copper)	1000m

## Static Discharge Cautionary

The following items are cautionary notes that will help prevent equipment damage or malfunction caused by static discharge:

### CAUTION

Static charges produce voltages high enough to damage electronic components. Follow these precautions when installing, servicing, or operating the AlarmLine II Digital EN Controller:

- Work in a static-free area.
- Discharge any static electricity you may have accumulated.
- Discharge static electricity by touching a known, securely grounded object.
- Do not handle the printed circuit board (PCB) without proper protection against static discharge.

In the event that the AlarmLine II Digital EN Controller malfunctions after encountering a static discharge correct operation of the unit can be restored by interrupting power to unit for a brief period (approximately 10 seconds). Setup information can be verified by following the steps in the Commissioning section (page 10 onwards). In the event of the setup information being corrupted the unit should be reset following the *Resetting the AlarmLine II Digital EN Controller procedure*.

## Mounting Dimensions

The AlarmLine II Digital EN Controller is intended to be wall-mounted. 4 holes should be drilled according to the mounting dimensions given in figure 2. The corresponding mounting holes on the AlarmLine II Digital EN Controller can be found by removing the lid of the device. The mounting holes are located adjacent to the lid screw positions. Suitable screws for the type of wall the AlarmLine II Digital EN Controller is to be mounted on will need to be provided for separately. The maximum screw head diameter is 7mm and the maximum screw thread diameter is 4mm.

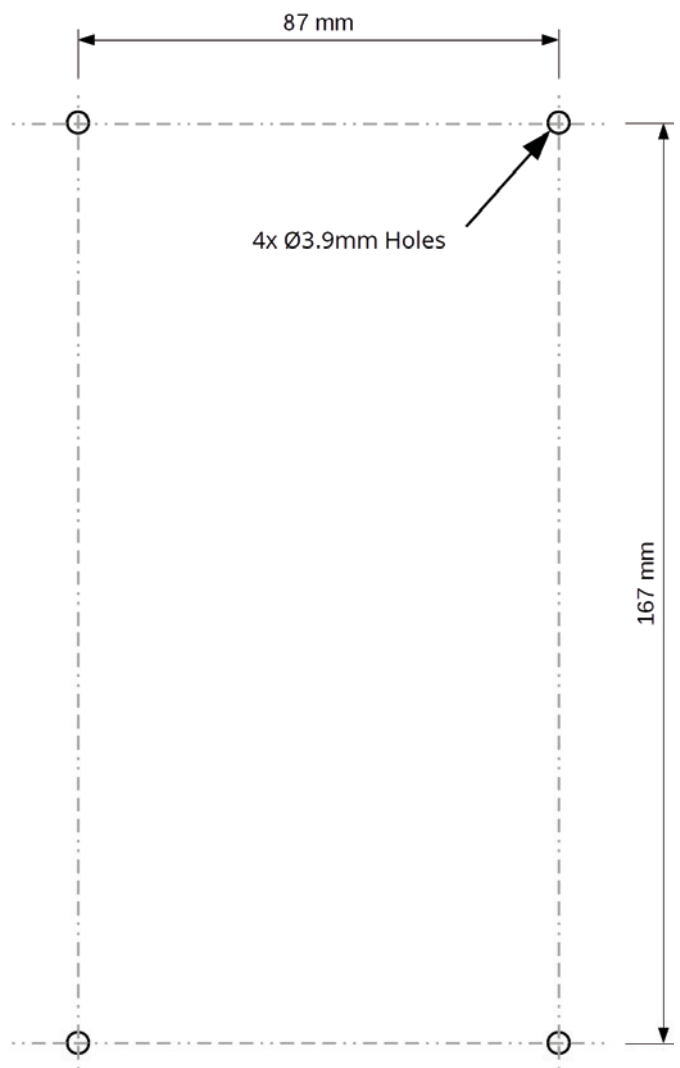

Figure 2: Mounting Dimensions for the Kidde AlarmLine II Digital EN Controller

# Commissioning

1. After wiring the unit up (see wiring diagram) power up the device. Device will show screen including software revision number.
2. If the unit is being setup for the first time the following options will be shown. If the unit has previously been installed the display will automatically cycle through the options, showing the stored settings.
3. After the initial title screen the next screen will show a menu (see right) with three options: Load Configs, New Configs and Self Test. On a previously configured device, after 10s of no button press the device will automatically proceed to loading saved configs.
4. If "Load Configs" is selected or no button has been pressed after 10s on a *previously configured device*, the screen will show "Loading Saved Configs". The previously saved parameters will then be displayed.
5. Select the operating mode. (see "Operating modes" (pages 7-8) for more detail.  
**Independent:** the two zones operate independently of each other (default).  
**Interlock:** Both fault outputs activate when a fault occurs on either zone 1 or zone 2. Both alarm outputs activate **only** when both Digital LHD zones trigger an alarm.
6. Select the relevant operating programme for Zone 1 based on the table below:

Alarm (or activation) temperature	Cable Set-Up	
	T078-V10-A045	T088-V10-A065
78°C (EN78)	✓	
88°C (EN88)		✓

7. Select the relevant operating programme for Zone 2 based on the table below:

Alarm (or activation) temperature	Cable Set-Up	
	T078-V10-A045	T088-V10-A065
78°C (EN78)	✓	
88°C (EN88)		✓

8. If leader cable is connected between the Digital LHD cable and the AlarmLine II Digital EN Controller and/or the LHD cable is installed in a hazardous area and IS barriers are being used, the voltage drop to the start of the LHD cable must be measured by the AlarmLine II Digital EN Controller in order to ensure correct operation and accurate distance location. In order to do this, with the leader cable and/or IS barriers and LHD cable connected to the AlarmLine II Digital EN Controller, short out the connection at the **start** of the LHD cable. Select "Yes" and press Set to continue.

KIDDE ADELCO-2  
SW REV 1.6

MAIN MENU  
LOAD CONFIGS

LOADING SAVED  
CONFIGS...

OPERATING MODE:  
INDEPENDENT

Z1 CABLE TYPE:  
T078-V10-A045

*In this example, the first option has been chosen for an alarm temperature of 78°C*

Z2 CABLE TYPE:  
T078-V10-A045

*In this example, the first option has been chosen for an alarm temperature of 78°C*

ZONE 1 LDR CABLE  
YES

## Commissioning (Cont.)

9. If "Yes" was selected in step 8, the AlarmLine II Digital EN Controller will then ask if the zone is ready to be calibrated. Ensure that the connection between the leader cable and/or the IS barriers and the **start** of the Digital LHD cable is securely shorted out between the two cores. When this is done, press the "Set" button to continue.

```
READY TO  
CALIBRATE?
```

10. The AlarmLine II Digital EN Controller will display the voltage drop across the leader cable. If necessary, press "Select" to perform the calibration measurement again. The AlarmLine II Digital EN Controller will display the updated voltage drop in mV (milli-volts). The displayed value should be equal to approximately the loop resistance in ohms from the AlarmLine II Digital EN Controller, with the short in place, divided by 8. Once the voltage drop has been confirmed correct, press "Set" to continue. **Now remove the short at the start of the LHD cable.**

```
ZONE 2 CAL:  
109 MV
```

11. If the Linear Heat Detection cable is connected directly to the AlarmLine II Digital EN Controller then select No and press the Set button to continue.

```
ZONE 2 LDR CABLE  
NO
```

12. Select whether you would like the alarm outputs for both zones to be latching. If set to Yes, then **if an alarm is triggered the unit will either require the power supply to be interrupted (min. 2s) or the Set button to be pressed to reset to normal once the alarm conditioned has been cleared.**

```
LATCHING OUTPUTS  
NO
```

13. Select whether the Modbus output should be enabled. If this is not enabled then proceed to step 17.

```
MODBUS OUTPUT ON  
YES
```

14. Select required Modbus type, either RTU or ASCII.

```
MODBUS TYPE  
RTU
```

15. Set the Modbus address for this device (1-247).

```
MODBUS ADDRESS  
1
```

16. Cycle through the possible Baud Rates for the Modbus RTU/ASCII output. (2400, 4800, 9600, 19200, 38400, 57600, 115200).

```
BAUD RATE  
2400
```

17. Select the number of data bits for the Modbus RTU/ASCII output. (7 or 8)

```
DATA BITS  
7
```

18. Select the number of stop bits for the Modbus RTU/ASCII output. (1 or 2).

```
STOP BITS  
1
```

19. Select the parity for the Modbus RTU/ASCII output. (even/odd/none).

```
PARITY  
EVEN
```

# Normal Operation

20. Once the unit has been commissioned, the display will show the zone status. In normal operation, the display unit in independent mode will show:

Zone 1: OK  
Zone 2: OK

The display unit in interlock mode will show:

{Zone 1: OK  
{Zone 2: OK

This indicates the two zones of LHD cable are linked and an alarm is only transmitted if both zones are triggered.

### Independent mode

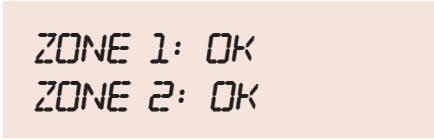

ZONE 1: OK  
ZONE 2: OK

### Interlock mode

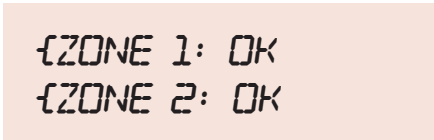

{ZONE 1: OK  
{ZONE 2: OK

### LED Illustration

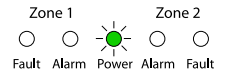
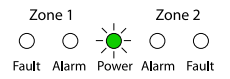

**Either of the display screens above and a single flashing Power light (green colour) should be visible when AlarmLine II Digital EN Controller is in normal operation.**

# Fault/Alarm Conditions

21. If an alarm condition occurs the AlarmLine II Digital EN Controller automatically calculates the distance along the cable to the trigger point and first displays this value in metres.

ZONE 1: 534 M  
ZONE 2: OK

## LED Illustration

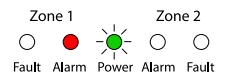

22. The display alternates showing the distance along the cable to the trigger point in metres and in feet.

ZONE 1: 1751 FT  
ZONE 2: OK

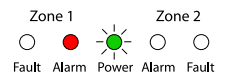

23. The unit monitors for relay faults. If an alarm condition occurs but the relay does not switch state (due to a coil failure for example) the device will go into relay fault and show the screen to the right, depending upon which zone is in fault

ZONE 1: RLY FLT  
ZONE 2: OK

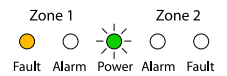

24. The unit monitors for interference faults when the input may be changing between alarm, ok and fault conditions, for example, too rapidly. In this case an I/F fault is displayed on the corresponding zone. Check all cable terminations are securely fastened and for other sources of noise.

ZONE 1: OK  
ZONE 2: I/F FAULT

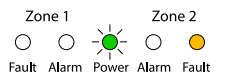

25. The unit monitors for cable faults (i.e. an open circuit). An open circuit will be displayed as fault (as per zone 1 shown right).

ZONE 1: FAULT  
ZONE 2: OK

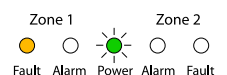

26. In interlock mode, the alarm outputs are only activated when both LHD cables are triggered. If one cable triggers but not the other the display will show the distance to the alarm on the triggered zone and the corresponding alarm LED will flash slowly.

{ZONE 1: 300M  
{ZONE 2: OK

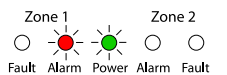

27. In interlock mode, if both cables go into an alarm, the alarm outputs will be activated and the display will show the distance to the alarm for each zone. The zone 1 and zone 2 alarm LEDs will light continuously.

{ZONE 1: 300M  
{ZONE 2: 301M



# Testing & Verification

## LED Illustration

1. If self test mode is selected the device will first load the saved configs then proceed to cycle through normal operation, alarm and fault. This is to allow the installer/maintenance engineer verify that the unit is connected to an external system correctly. The screen will flash "SELF TEST/MODE" every few seconds.

SELF TEST  
MODE

### Independent mode

ZONE 1: OK  
ZONE 2: OK

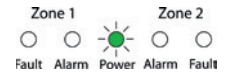

### Interlock mode

{ZONE 1: OK  
{ZONE 2: OK

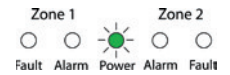

### Independent mode

ZONE 1: ALM  
ZONE 2: ALM

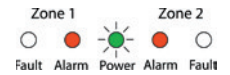

### Interlock mode

{ZONE 1: ALM  
{ZONE 2: ALM

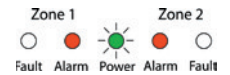

### Independent mode

ZONE 1: FAULT  
ZONE 2: FAULT



### Interlock mode

{ZONE 1: FAULT  
{ZONE 2: FAULT



3. In self test mode and alarm condition the display will show alarm. The alarm relays will be on. After approx. 8 seconds the unit will go into fault condition.

4. In self test mode and fault condition the display will show fault. The fault outputs will stop conducting (off). After approx. 8 seconds the unit will return to normal condition. To exit self test mode, press and hold both SET and SELECT buttons for 10s or more until the device resets.

## Two-wire RS-485 Modbus RTU/ASCII Communications

---

The Kidde AlarmLine II Digital EN Controller includes a two wire RS-485 Modbus output which can be enabled to output the status of each zone of Digital Linear Heat Detection cable. The AlarmLine II Digital EN Controller Modbus output supports the Modbus RTU/ASCII protocol and the following functions:

- Function code 4 (Read Input Registers)

The request for reading the input registers should be constructed in the following manner:

- Address of first register to be read (16-bit)
- Number of registers to read (16-bit)

The AlarmLine II Digital EN Controller will respond in the following manner:

- Number of bytes of register values to be read (8-bit)
- Register values (16-bits per register)

The AlarmLine II Digital EN Controller stores the information for each zone of the Digital LHD cable in the following format:

Register	Description	Possible Values
0	Zone 1 status	-1 or 65535=fault on zone 0=zone ok 1-32767=distance in metres to trigger point
1	Zone 2 status	-1 or 65535=fault on zone 0=zone ok 1-32767=distance in metres to trigger point
2	Zone 1 cable type	1 = T078-V10-A045 (EN78), 2 = T088-V10-A065 (EN88)
3	Zone 2 cable type	1 = T078-V10-A045 (EN78), 2 = T088-V10-A065 (EN88)

If the start address plus the requested number of registers exceed 4, the AlarmLine II Digital EN Controller will return an ILLEGAL DATA ADDRESS error.

If the request contains a function code other than those supported the AlarmLine II Digital EN Controller will return an ILLEGAL FUNCTION error.

# Resetting the AlarmLine II Digital EN Controller

---

**WARNING:** This procedure will erase ALL stored settings and reset the Kidde AlarmLine II Digital EN Controller back to its factory default state. The cable types, leader cable calibration, latching output selection and Modbus setup will all require selecting after this procedure.

To reset the AlarmLine II Digital EN Controller back to the factory state, when the unit is powered up and in normal operation (see step 20 in the Commissioning procedure), press and hold the SET and SELECT buttons for a minimum of 10 seconds continuously. While the SET and SELECT buttons are held down the power LED will flash quickly to confirm this procedure is about to take place. After approximately 10 seconds, the unit will restart and return to step 1 in the Commissioning procedure. The settings are only erased if the menu option "New Configs" is selected.

## Product warnings and disclaimers

---

THESE PRODUCTS ARE INTENDED FOR SALE TO AND INSTALLATION BY QUALIFIED PROFESSIONALS. UTC FIRE & SECURITY CANNOT PROVIDE ANY ASSURANCE THAT ANY PERSON OR ENTITY BUYING ITS PRODUCTS, INCLUDING ANY "AUTHORIZED DEALER" OR "AUTHORIZED RESELLER", IS PROPERLY TRAINED OR EXPERIENCED TO CORRECTLY INSTALL FIRE AND SECURITY RELATED PRODUCTS.

For more information on warranty disclaimers and product safety information, please check <https://firesecurityproducts.com/policy/product-warning/> or scan the QR code:





# Glossary

---

**Alarm condition** – A fire or overheat around the Digital LHD cable which activates the cable and triggers the AlarmLine II Digital EN Controller.

---

**Cable glands** – Used to form a dust-proof and weatherproof seal around a cable entering the AlarmLine II Digital EN Controller.

---

**Digital linear heat detection cable** – a sensing cable comprised of a pair of twisted low resistance conductors that fuse together at a specific temperature and induce an alarm on a fire panel or interface module.

---

**End of line resistor** – A component which allows a residual current flow through a circuit to monitor the integrity of the circuit. In the event of a break in the circuit, current will stop flowing completely and a trouble or fault signal will be triggered.

---

**Fault condition** – A break in one or both cores of the Digital LHD cable or a malfunction of the AlarmLine II Digital EN Controller.

---

**Independent mode** – The mode on the AlarmLine II Digital EN Controller where both zones operate separately. Each zone can trigger a fault or alarm, or be in the normal state, regardless of the state of the other zone.

---

**Interlock mode** – The mode on the AlarmLine II Digital EN Controller where the alarm relay outputs will only activate when both Digital LHD cables go into alarm. If one cable triggers but not the other, the alarm relay outputs will not be triggered.

---

**Junction box** – A secure, dust-proof and weatherproof enclosure to protect a join between two lengths of Digital LHD cable or a length of Digital LHD cable and leader cable.

---

**Leader cable** – A non-temperature sensing cable which transmits the signals between two components in the system, e.g. the AlarmLine II Digital EN Controller and the Digital LHD cable. Does not provide fire detection and may be fire-rated to continue functioning even in a fire condition.

---

**Two-wire RS-485 Modbus RTU/ASCII Communications** – An industry standard, signalling protocol used to communicate information between components in a system, for example a SCADA system or PLC. Often used to provide more information to be communicated than simple open or closed status communicated by a relay output.

---

**Zone** – a single circuit of AlarmLine II linear heat detection cable connected across either a AlarmLine II Digital EN Controller or a fire panel and an end of line resistor.