

User Manual

OLC 10 OLCT 10

**Analog Gas Detector
Non ATEX version**



Part Number : NPO10GB-NEX
Revision : ZZ.1

OLDHAM



SIMTRONICS
Fire & Gas

User Manuals in others language are available on Website
<https://teledynegasandflamedetection.com>



Copyright © December 2019 by OLDHAM SIMTRONICS S.A.S.

All rights reserved. No reproduction of all or part of this document, in any form, is permitted without the written consent of Oldham Simtronics S.A.S.

All of the information that is provided in this document is accurate to the best of our knowledge. As a result of continuous research and development, the specifications of this product may be changed without prior notice.

Oldham Simtronics S.A.S.
Rue Orfila
C.S. 20417
F – 62027 ARRAS

TABLE OF CONTENTS

I. PRESENTATION OF DIFFERENT VERSIONS.....	3
Different versions available	3
II. MECHANICAL INSTALLATION OF DIFFERENT VERSIONS, DIMENSIONS AND MOUNTING	3
III. ELECTRICAL INSTALLATION OF DIFFERENT VERSIONS.....	5
1. Connection of OLC 10, OLCT 10 EXPLO or OLCT 10 SC (Semi-Conductor) to a controller for combustible gas detection:.....	5
2. Connection of two OLC 10 TWIN to a controller	6
3. Connection of two OLCT 10 TOX (maximum 5) to a controller for detection of the same toxic gas	7
4. Connection of two OLCT 10 TOX networks (5 detectors max. per network) for detection of two different toxic gases or monitoring of two conjoined areas to a two-channel controller.....	8
IV. MAINTENANCE.....	9
1. Periodic maintenance with an OLC 10 detector (comb. gas)	9
2. Periodic maintenance with an OLC 10 TWIN transmitter (comb. gas)	9
3. Periodic maintenance with an OLCT 10 transmitter (comb. or toxic gas)	9
4. Periodic maintenance with several OLCT 10 transmitters for toxic gas	11
5. Sensor replacement	11
V. TECHNICAL SPECIFICATIONS	13
1. TECHNICAL SPECIFICATIONS - OLC 10 / OLC 10 Twin	13
2. TECHNICAL SPECIFICATIONS - OLCT 10 Explo Transmitter	14
3. TECHNICAL SPECIFICATIONS - OLCT 10 CO Transmitter	15
4. TECHNICAL SPECIFICATIONS - OLCT 10 SC Transmitter.....	16
5. TECHNICAL SPECIFICATIONS - OLCT 10 NO Transmitter.....	17
6. TECHNICAL SPECIFICATIONS - OLCT 10 NO2 Transmitter.....	18
VI. DETAIL SPECIFICATIONS FOR USE.....	19
1. Special precautions	19
2. <i>Reactions to other combustible gases</i>	19
VII. DECLARATIONS OF CONFORMITY	21

Limitation of Liability

- The Company OLDHAM SIMTRONICS S.A.S., hereinafter referred to as “OLDHAM SIMTRONICS” throughout this document, shall not be held responsible for any damage to the equipment or for any physical injury or death resulting in whole or in part from the inappropriate use or installation of the equipment, non-compliance with any and all instructions, warnings, standards and/or regulations in force.
- No business, person or legal entity may assume responsibility on behalf of OLDHAM SIMTRONICS, even though they may be involved in the sale of OLDHAM SIMTRONICS products.
- OLDHAM SIMTRONICS shall not be responsible for any direct or indirect damage, or any direct or indirect consequence, resulting from the sale and use of any of its products **UNLESS SUCH PRODUCTS HAVE BEEN SELECTED BY OLDHAM SIMTRONICS ACCORDING TO THE APPLICATION.**

Ownership clauses

- The drawings, specifications, and information herein contain confidential information that is the property of OLDHAM SIMTRONICS.
- This information shall not, either in whole or in part, by physical, electronic, or any other means whatsoever, be reproduced, copied, divulged, translated, or used as the basis for the manufacture or sale of OLDHAM SIMTRONICS equipment, or for any other reason **without the prior consent of OLDHAM SIMTRONICS.**

Warning

- This is not a contractual document. In the best interest of its customers and with the aim of improving performance, OLDHAM SIMTRONICS reserves the right to alter the technical features of its equipment without prior notice.
- READ THESE INSTRUCTIONS CAREFULLY BEFORE THE FIRST USAGE:** these instructions should be read by all persons who have or will have responsibility for the use, maintenance, or repair of the instrument.
- This instrument shall only be deemed to be in conformance with the published performance if used, maintained, and repaired in accordance with the instructions of OLDHAM SIMTRONICS by OLDHAM SIMTRONICS personnel or by personnel authorized by OLDHAM SIMTRONICS.

Important Information

- The modification of the material and the use of parts of an unspecified origin shall entail the cancellation of any form of warranty.
- The use of the unit has been projected for the applications specified in the technical characteristics. Exceeding the indicated values cannot in any case be authorized.
- OLDHAM SIMTRONICS recommends regular testing of fixed gas detection installations (read Chapter IV).
- Before any intervention on the detector, please refer to the EN 60079-29-2 standard.

Warranty

- Under normal conditions of use and on return to the factory, OLC/OLCT10 detectors carry a 2-year warranty excluding accessories such as sensors, filters, etc.

Destruction of the equipment

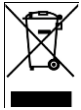

European Union (and EEA) only. This symbol indicates that, in conformity with directive DEEE (2002/96/CE) and according to local regulations, this product may not be discarded together with household waste.

It must be disposed of in a collection area that is set aside for this purpose, for example at a site that is officially designated for the recycling of electrical and electronic equipment (EEE) or a point of exchange for authorized products in the event of the acquisition of a new product of the same type as before.

I. PRESENTATION OF DIFFERENT VERSIONS

The **OLC 10**, **OLC 10 TWIN** and **OLCT 10 EXPLO** combustible gas detectors are detectors fitted with catalytic sensors and intended for use in boiler rooms and parking lots.

The **OLCT 10 TOX** gas detectors are 4-20mA transmitters equipped with electrochemical sensors and especially designed to detect toxic gases in commercial and light industrial applications (parking lots, boiler room, etc).

Different versions available

- OLC 10: combustible gas
- OLC 10 TWIN: combustible gas
- OLCT 10 EXPLO: combustible gas (transmitter version, 4-20 mA output)
- OLCT 10 TOX: toxic gas (transmitter version, 4-20 mA output)

II. MECHANICAL INSTALLATION OF DIFFERENT VERSIONS, DIMENSIONS AND MOUNTING

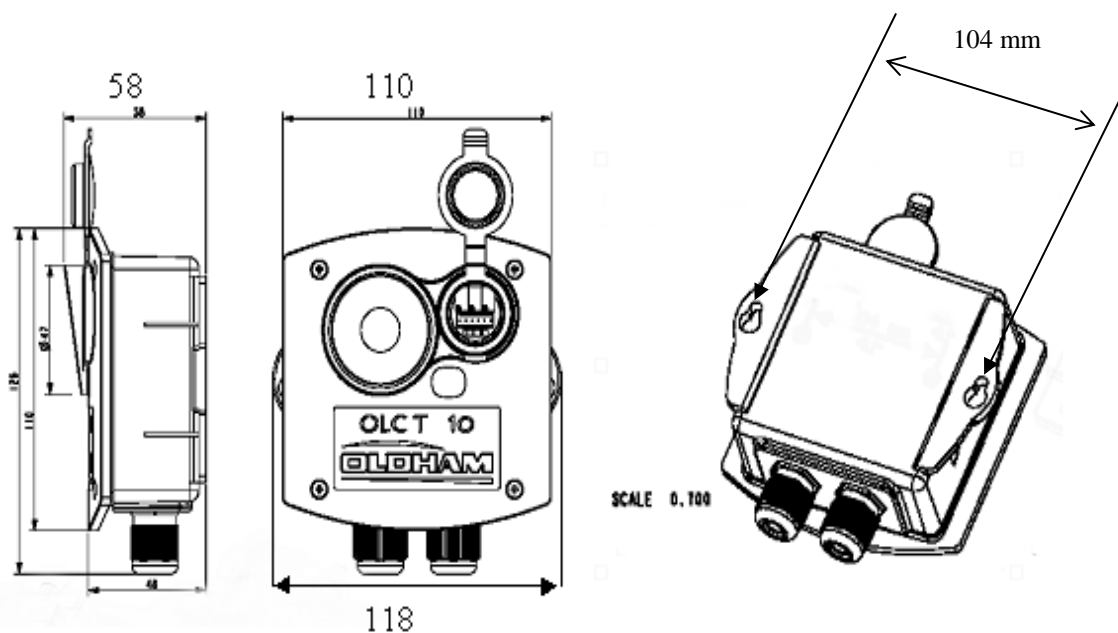

The OLC/OLCT 10 gas detectors-transmitters are mounted vertically with the cable entries positioned downwards.

Drill two holes **104 mm** apart on the base to mount the units.

III. ELECTRICAL INSTALLATION OF DIFFERENT VERSIONS

1. Connection of OLC 10, OLCT 10 EXPLO or OLCT 10 SC (Semi-Conductor) to a controller for combustible gas detection:

- Notes:
- The controller configuration will be different based upon the use of an OLC 10 or OLCT 10
 - Cable to be used: 3 conductors, 3x1 mm² LiYCY type

e.g., *CONTROLLER MX 15*

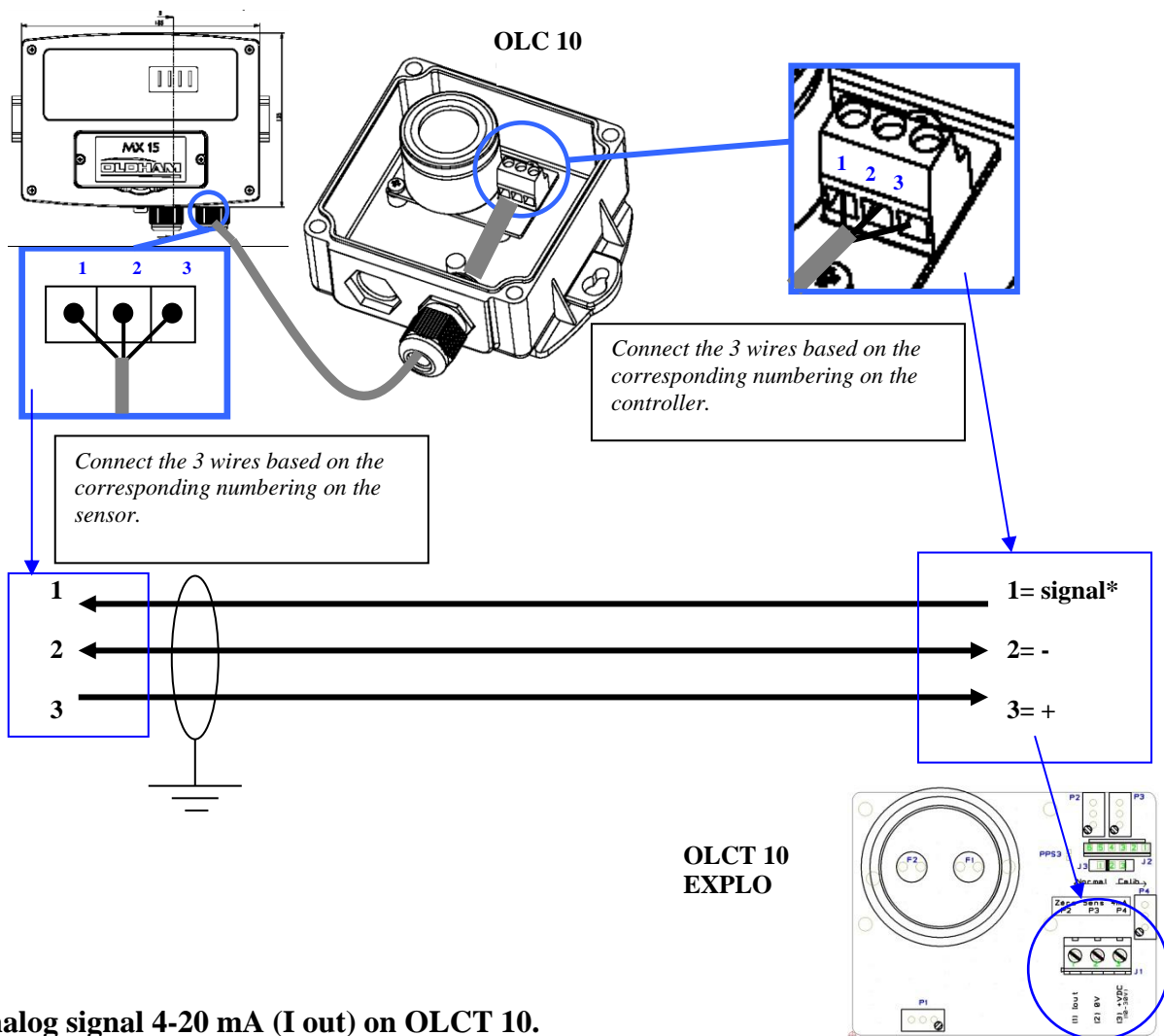

2. Connection of two OLC 10 TWIN to a controller

Cable to be used: 3 and 4 core cable, 3x1 mm² and 4x1 mm² LiYCY type

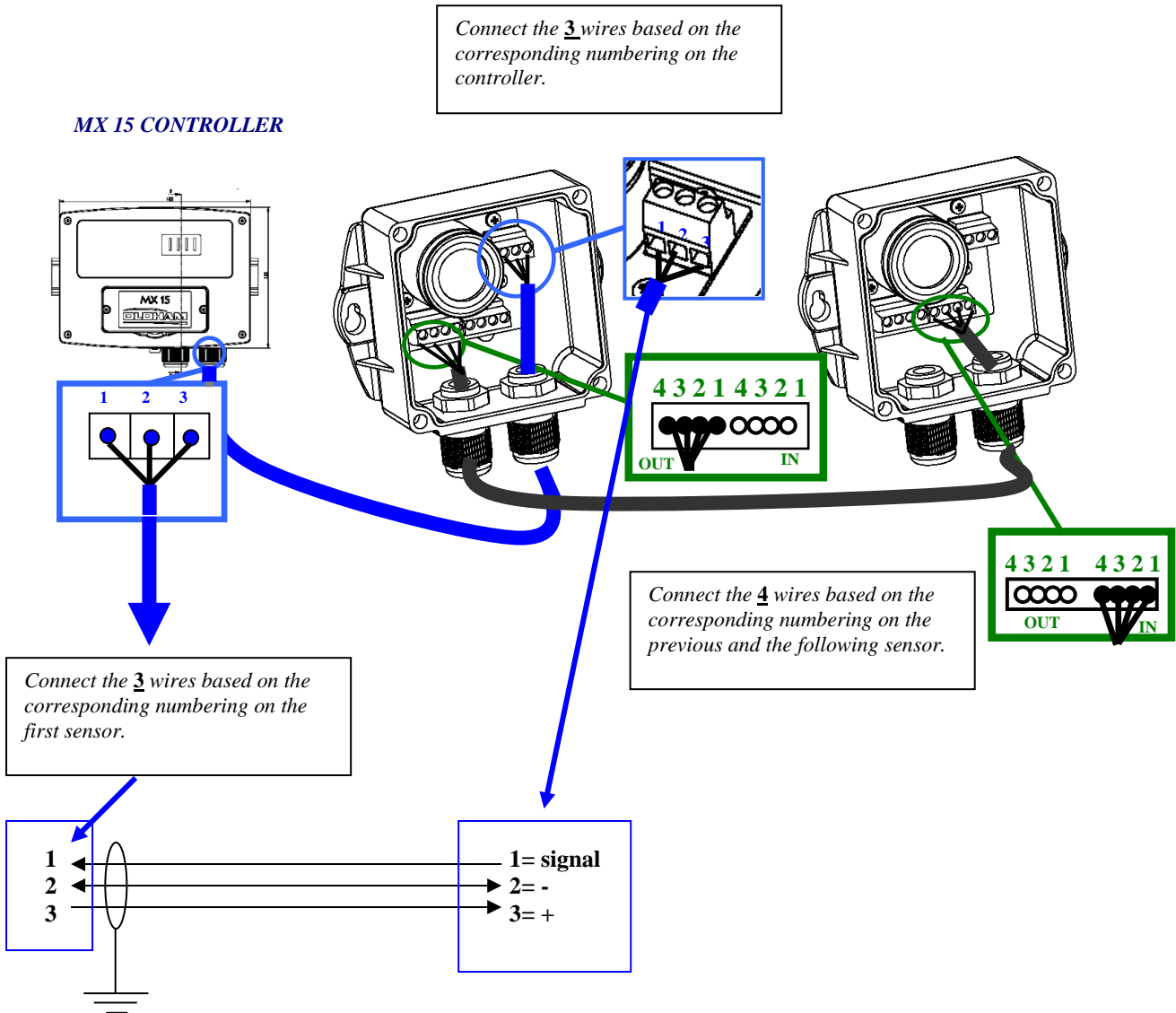

3. Connection of two OLCT 10 TOX (maximum 5) to a controller for detection of the same toxic gas

Cable to be used: One pair (0.75 mm²) screened cable

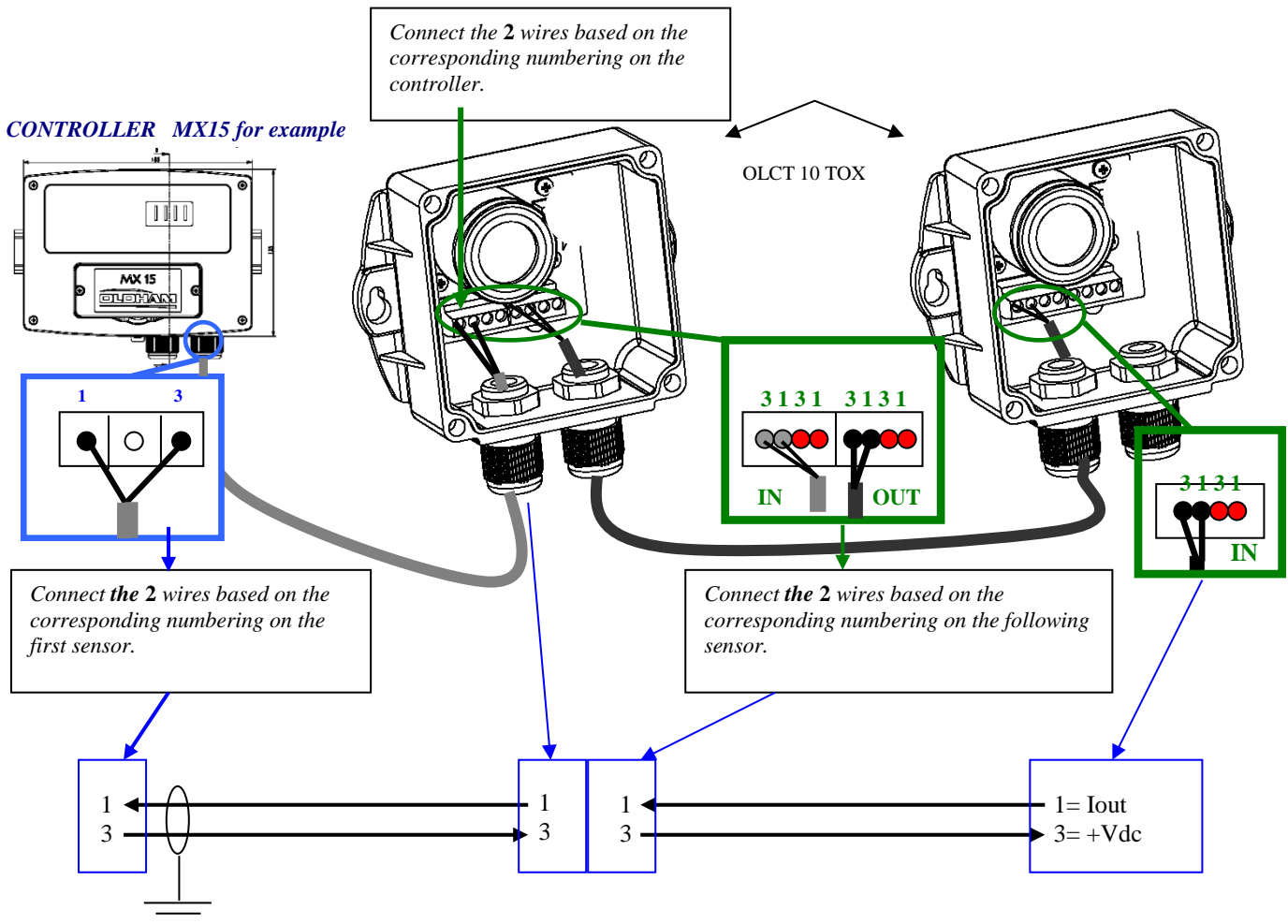

Note: the free terminals ● allow the connection of another network of OLCT 10 TOX.

COMMENTS:

- the number of OLCT 10 toxic gas detectors shall be configured on the controller,
- the signal read by the controller is the average of the “n” detectors. As a result, a signal fault may not be detected.

In the event that 2 networks are used, it is cost-effective to use a single cable (2 pairs) subject to compliance with wiring as follows:

4. Connection of two OLCT 10 TOX networks (5 detectors max. per network) for detection of two different toxic gases or monitoring of two conjoined areas to a two-channel controller

Cable to be used: Two pairscreened cable (0.75 mm²)

OLCT 10 TOX Example: one zone, 2 gases

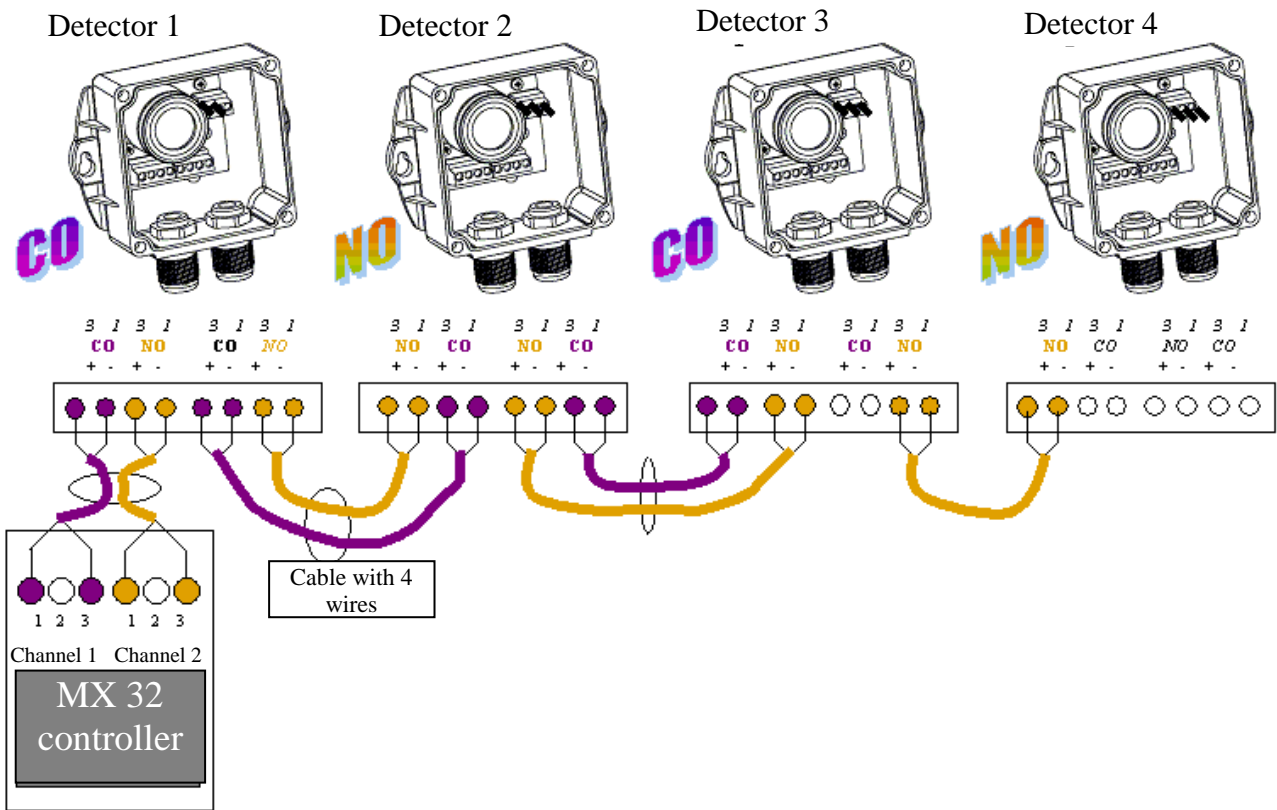

Controller with 2 channels at minimum

Information for this example:

- channel 1 is a channel connected to two sensors for detection of CO
- channel 2 is a channel connected to two sensors for detection of NO
- detector 1 (CO) also acts as junction box for detector 2 (NO)
- detector 2 (NO) also acts as junction box for detector 3 (CO)
- detector 3 (CO) also acts as junction box for detector 4 (NO)

IV. MAINTENANCE

Caution: The actions described in this paragraph are intended for authorized and trained individuals who are likely to question the detection safety.

Gas detection instruments are potential life-saving devices. Recognizing this fact, OLDHAM SIMTRONICS recommends that a functional “bump” test be performed on every fixed gas-monitoring instrument as part of a regular maintenance program. A functional test is defined as a brief exposure of the detector to a concentration of gas(es) in excess of the lowest alarm set-point for each sensor for the purpose of verifying sensor and alarm operation and is not intended to be a measure of the accuracy of the instrument.

Bump test frequency depends on application, field conditions, exposure to gas, sensor technology, and environmental conditions. For new installations it may be prudent to carry out bump tests frequently at first, increasing the time intervals as confidence grows with experience in the installation concerned, on the basis of the maintenance record. The maintenance test interval should not be more than 3 months.

If an instrument fails to operate properly during any functional “bump” test, a full instrument calibration should be performed successfully prior to use. Calibration frequency will be based on bump tests results. However it cannot be more than 12 months.

These recommendations are based on safe work procedures, industry best practises, and regulatory standards to ensure worker safety. OLDHAM SIMTRONICS is not responsible for setting safety practices and policies.

1. Periodic maintenance with an OLC 10 detector (comb. gas)

- The “maintenance” position was selected on the controller in order to disable its relays (see manual of relevant product)

Reminder: make sure the detector is in clean air - otherwise inject zero air on the detector (with calibration kit) with a flow rate of 60 l/h, then wait for the stabilisation of measurement

- Perform the zero setting of the controller (see manual of relevant product)
- Now inject the calibration gas (flow rate 60l/h) into the OLC 10 sensor and wait for signal stabilisation on the controller display
- If necessary, calibrate the sensitivity using the “S” potentiometer of the controller (see manual of relevant product)
- Upon completion of calibration: wait for the “return to zero” on the controller display
- Return to the “normal” mode of the controller (see manual of relevant product)

2. Periodic maintenance with an OLC 10 TWIN transmitter (comb. gas)

- The procedure is almost identical to point 1 (OLC 10), with the exception of sensitivity adjustment which is performed on the OLC 10 TWIN detector that is less sensitive.
- To determine the least sensitive detector, inject gas on the two detectors, one after the other (wait for the signal to read zero). The detector that gives the lowest measurement is the less sensitive.

3. Periodic maintenance with an OLCT 10 transmitter (comb. or toxic gas)

- It is required that the kit provided by OLDHAM SIMTRONICS be used (P/N 6147872)
- Remove the end-cap that provides access to settings, located on the right side of the sensor
- Connect this kit on the male plug of the circuit, as indicated below:

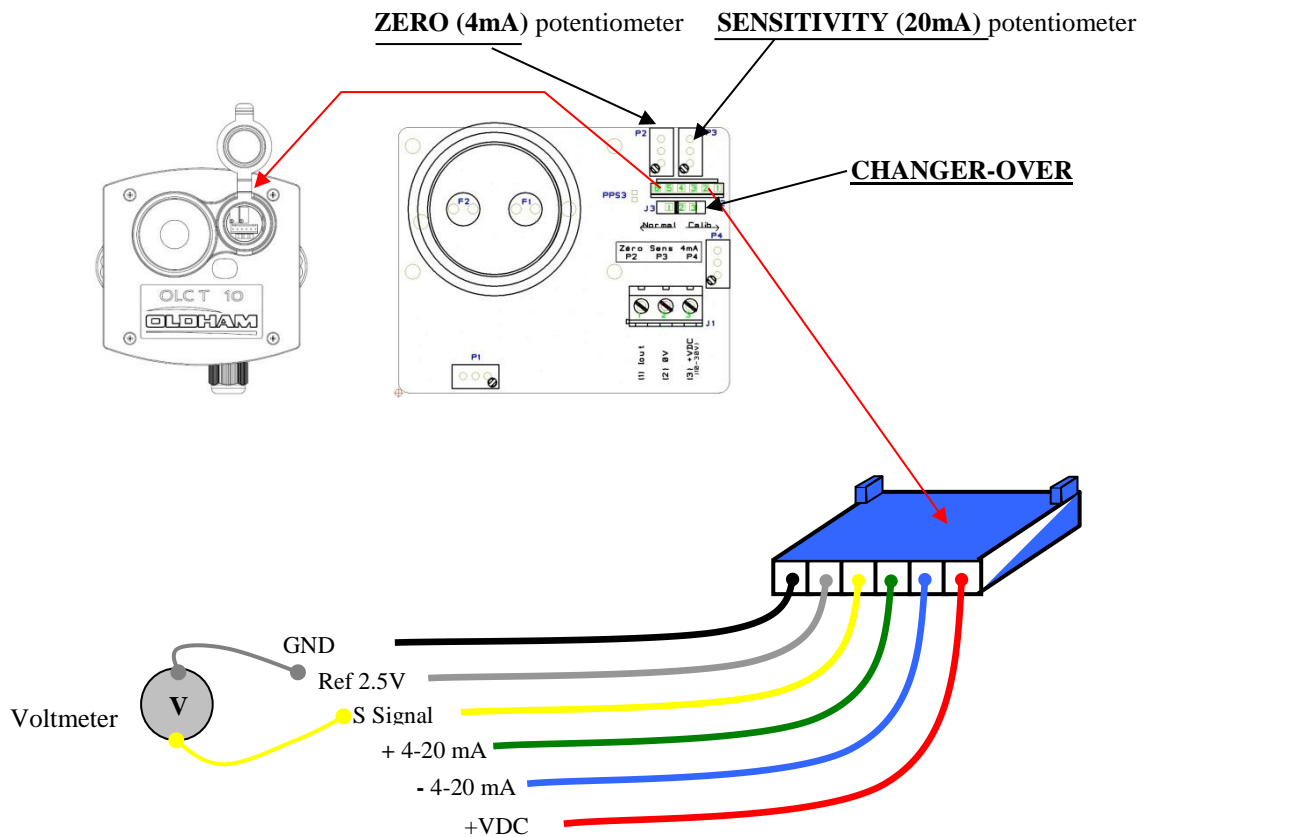

MAINTENANCE CONNECTOR WIRES:

- +VDC/red = + power supply
 - - 4-20 mA/blue = - of voltage, image of 4-20mA
 - + 4-20 mA/green = + of voltage, image of 4-20mA
 - S Signal /yellow = signal from 0mV to 1600mV for zero and sensitivity setting
 - Ref 2.5 V/gray = zero reference for reading of signal from 0mV to 1600mV
 - GND/black = electronic circuit ground.
- } Read on the voltmeter 400mV for 4mA and 2000mV for 20mA
- } **voltmeter**

- Toggle the changer-over (under the connector) on «CAL» position (to the right)

Caution: after 9 minutes the transmitter automatically returns to normal operation! (only version OLCT 10 explo)

Reminder: make sure the detector is in clean air - otherwise inject zero air or nitrogen on the sensor at a flow rate of 60 l/h – and wait for the stabilisation of the measurement given by the voltmeter.

- Set the **ZERO** using the zero potentiometer to read **0 mV** on the voltmeter
- Now inject the calibration gas (60l/h), wait for the signal stabilisation on the voltmeter
- If required, set the sensitivity using the “S” potentiometer to read **1,600mV** for the **full scale** (corresponding to **20mA**)
- Note: if you use a gas concentration lower than 100% of the scale, calculate (rule of three) and adjust to obtain the corresponding value (from 0 to 1600 mV)
- Stop calibration gas injection (remove the calibration cup)
- Wait for the “return to zero” on the voltmeter
- Again toggle the changer-over to the normal position (to the left)

Notes regarding the OLCT 10 version for combustible gases:

- the transmitter controls an “**ambiguity resolution**” function: if the sensor detects a gas concentration over 100% LEL (20 mA), it will be locked on a signal of 23.2 mA acknowledgeable through power supply shut-off or toggling of maintenance switch. The ambiguity resolution may be automatically acknowledged if the PPS3 points are short-circuited.

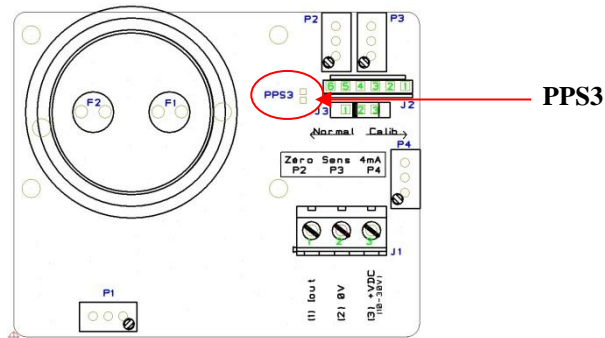

- Upon switching on, the output signal is set to 2mA during the 60-second stabilisation time.

4. Periodic maintenance with several OLCT 10 transmitters for toxic gas

Use the procedure described in the previous paragraph. However:

- Start with the last transmitter in the loop in relation to the controller
- Calibrate each transmitter in the loop and end with the first

5. Sensor replacement

Sensor has to be replaced as a result of impracticable calibration or as a preventive measure. Perform a new calibration after a sensor replacement.

V. TECHNICAL SPECIFICATIONS

1. TECHNICAL SPECIFICATIONS - OLC 10 / OLC 10 Twin

Combustible gas detector

Detection principle:	Catalytic
Range:	0-100% LEL methane, propane or butane.
Output signal:	Wheatstone bridge circuit
Power supply:	Current through Oldham Simtronics MX controllers
Connections:	OLC 10 Version: <ul style="list-style-type: none">- 3-wire terminal block, maximum distance 300 m in 1.5 mm² with MX 15 controller- 1 cable gland M16: cable diameter 4 to 8 mm OLC 10 Twin Version (two sensors on channel input MX 15) <ul style="list-style-type: none">- 1 3-wire terminal block to the controller- 1 4-wire terminal block to the second sensor- maximum total distance 300 m in 1.5 mm² with MX 15 controller- 2 cable glands M16: cable diameter 4 to 8 mm
Dimensions:	Width 118 mm, Height 157 mm, Depth 60 mm
Material:	Plastic
Protection:	IP65
Storage:	6 months safe from air 0°C<T<20°C +10%<RH<60%
Estimated lifetime:	> 36 months
Temperature range:	-10°C to + 45°C
Humidity range:	0% RH to 95% RH
Pressure range:	1 bar ± 20%
Linearity deviation:	from 0 and 70% LEL: ≤ 1% LEL CH ₄ from 70 and 100% LEL: ≤ 7% LEL CH ₄
Long-term drift under normal operating conditions:	Zero < 10% LEL/year Sensitivity < 20 % of the measured value/year
Humidity impact: (10 to 90% RH) at 40°C	± 5 % of relative sensitivity
Response time:	T ₅₀ <10 sec, T ₉₀ <20 sec
Certification:	Electromagnetic Compatibility EN 50270 :2015 (type2)

2. TECHNICAL SPECIFICATIONS - OLCT 10 Explo Transmitter

Combustible gas transmitter

Detection principle:	Catalytic
Range:	0-100% LEL methane, propane or butane.
Signal output:	4 – 20 mA, default ≤ 0.5 mA or ≥ 23.2 mA
Ambiguity resolution:	signal sets at 23.2 mA if measurement $\geq 100\%$ LEL Acquit by power cycling the transmitter Ambiguity resolution may be deleted through point of programming
Settings:	Local through Zero and Sensitivity potentiometers Position Maintenance 2 mA 6-pin connector for gas measuring and current image (100-ohm shunt)
Power supply:	15 to 30 V dc
Consumption:	maximum 100 mA
Cable length:	according to the controller
Load resistance:	300 ohms
Connection:	3-wire terminal block, 2 wires for power supply, 1 wire for signal 1 cable gland M16: cable diameter 4 to 8 mm
Dimensions:	Width 118 mm, Height 157 mm, Depth 60 mm
Material:	Plastic
Protection:	IP65
Storage:	$0^{\circ}\text{C} < T < 30^{\circ}\text{C}$
Estimated lifetime:	> 36 months
Temperature range:	-10 to $+4^{\circ}\text{C}$
Humidity range:	0% RH to 95% RH
Pressure range:	1 bar $\pm 20\%$
Linearity deviation:	from 0 and 70% LEL: $\leq 1\%$ LEL CH4 from 70 and 100% LEL: $\leq 7\%$ LEL CH4
Temperature drift: (-10°C + 40°C)	$< \pm 5\%$ LEL Methane or $< 20\%$ of indication
Long-term drift under normal operating conditions:	Zero point $< 10\%$ LEL methane Sensitivity $< 20\%$ of measured value/year
Humidity impact: (10 to 90% RH) at 40°C	$\pm 5\%$ of relative sensitivity
Response time:	T50 < 10 sec, T90 < 20 sec
Certification:	Electromagnetic Compatibility EN 50270 :2015 (type2)

3. TECHNICAL SPECIFICATIONS - OLCT 10 CO Transmitter

Detection principle:	Electrochemical sensor
Range:	0-300 ppm CO
Signal output:	4 – 20 mA
Settings:	Local through Zero and Sensitivity potentiometers Position Maintenance 2 mA 6-pin connector for gas measuring and current image (100-ohm shunt)
Power supply:	15 to 30 VDC
Consumption:	maximum 30 mA
Cable length:	according to the controller
Connection:	1 terminal block with 2 input wires, 1 terminal block with 2 output wires If cable with a gas signal pair: 1 terminal block with 2 input wires with copy on 1 terminal with 2 wires 2 cable gland M16: cable diameter 4 to 8 mm
Dimensions:	Width 118 mm, Height 157 mm, Depth 60 mm
Material:	Plastic
Protection:	IP65
Storage:	6 months safe from air $0^{\circ}\text{C} < T < 20^{\circ}\text{C}$ $+10\% < \text{RH} < 60\%$
Estimated lifetime:	> 24 months
Temperature range:	-10 to + 45°C
Humidity range:	15% RH to 90% RH
Pressure range:	1 bar \pm 20%
Linearity deviation:	0 - 100 ppm \pm 3 ppm 100 – 1,000 ppm \pm 4% relative
Temperature drift: (-10°C + 40°C)	$< \pm 5$ ppm or $< 5\%$ of the indication
Long-term drift under normal operating conditions:	Sensitivity: $< 10\%$ of measured value/year
Response time:	T50 < 15 sec, T90 < 30 sec
Certification:	Electromagnetic Compatibility EN 50270 :2015 (type2)

4. TECHNICAL SPECIFICATIONS - OLCT 10 SC Transmitter

Detection principle:	semi-conductor sensor
Range:	0-2000 ppm R134A, R22
Signal output:	4 – 20 mA
Settings:	Local through Zero and Sensitivity potentiometers Position Maintenance 2 mA 4-pin connector for gas measuring and current image (100-ohm shunt)
Power supply:	15 to 30 VDC
Consumption:	maximum 100 mA
Cable length:	according to the controller
Connection:	3-wire terminal block, 2 wires for power supply, 1 wire for signal 1 cable gland M16: cable diameter 4 to 8 mm
Dimensions:	Width 118 mm, Height 157 mm, Depth 60 mm
Material:	Plastic
Protection:	IP65
Storage:	6 months safe from air $0^{\circ}\text{C} < T < 30^{\circ}\text{C}$
Estimated lifetime:	> 24 months
Temperature range:	-10 to + 60°C
Humidity range:	20% RH to 90% RH
Pressure range:	1 bar \pm 10%
Linearity deviation:	0 - 10 ppm \pm 0.3 ppm 10 – 30 ppm \pm 5% relative
Temperature drift: (-10°C + 40°C)	< \pm 0.4 ppm or < 20 % of the indication
Long-term drift under normal operating conditions:	Sensitivity: < 20% of measured value/year
Response time:	T50 < 51s (R22) T50 < 30 sec, (R134a)
Minimum sensitivity threshold	10 ppm
Maximum sensitivity threshold	5000 ppm during 90s without sensitivity loss
Recommended Alarm Threshold	200 ppm
Minimum time to detect the lowest concentration	less than 25s after injection of 500 ppm R134A
Recovery time	less than 160s after injection of 8 min of 1000 ppm R134A
Certification:	Electromagnetic Compatibility EN 50270:2015 (type2) In accordance with EN 14624 certification

5. TECHNICAL SPECIFICATIONS - OLCT 10 NO Transmitter

Detection principle:	electrochemical sensor
Range:	0-100 ppm NO
Signal output:	4 – 20 mA
Settings:	local through Zero and Sensitivity potentiometers Position Maintenance 2 mA 4-pin connector for gas measuring and current image (100-ohm shunt)
Power supply:	15 to 30 VDC
Consumption:	maximum 30 mA
Cable length:	according to the controller
Connection:	1 terminal block with 2 input wires, 1 terminal with 2 output wires If cable with other gas signal pair: 1 terminal block with 2 input wires with copy on 1 terminal block with 2 wires 2 cable glands M16: cable diameter 4 to 8 mm
Dimensions:	Width 118 mm, Height 157 mm, Depth 60 mm
Material:	Plastic
Protection:	IP65
Storage:	6 months safe from air $0^{\circ}\text{C} < T < 20^{\circ}\text{C}$ $+10\% < \text{RH} < 60\%$
Estimated lifetime:	> 36 months
Temperature range:	-10 to + 45°C
Humidity range:	15% RH to 90% RH
Pressure range:	1 bar \pm 20%
Linearity deviation:	0 - 10 ppm \pm 3 ppm 10 - 100 ppm \pm 5 % relative
Temperature drift: (-10°C + 40°C)	< \pm 10 ppm or < 10% of the indication
Long-term drift under normal operating conditions:	Sensitivity: < 20% of measured value/year
Response time:	T90 < 120 sec
Certification:	Electromagnetic Compatibility EN 50270:2015 (type2)

6. TECHNICAL SPECIFICATIONS - OLCT 10 NO2 Transmitter

Detection principle:	electrochemical sensor
Range:	0-30 ppm NO ₂
Signal output:	4 – 20 mA
Settings:	local through Zero and Sensitivity potentiometers Position Maintenance 2 mA 4-pin connector for gas measuring and current image (100-ohm shunt)
Power supply:	15 to 30 VDC
Consumption:	30 mA max
Cable length:	according to the controller
Connection:	1 terminal block with 2 input wires, 1 terminal block with 2 output wires If cable with other gas signal pair: 1 terminal block 2 input wires with copy on 1 terminal block with 2 wires 2 cable glands M16: cable diameter 4 to 8 mm
Dimensions:	Width 118 mm, Height 157 mm, Depth 60 mm
Material:	Plastic
Protection:	IP65
Storage:	6 months safe from air 0°C<T<20°C +10%<RH<60%
Estimated lifetime:	> 24 months
Temperature range:	-10 to + 50°C
Humidity range:	15% RH to 90% RH
Pressure range:	1 bar ± 20%
Linearity deviation:	0 - 10 ppm ± 0.3 ppm 10 - 30 ppm ± 5 % relative
Temperature drift: (-10°C + 40°C)	< ± 0.4 ppm or < 20% of indication
Long-term drift under normal operating conditions:	Sensitivity: < 20% of measured value/year
Response time:	T90 < 60 sec
Certification:	Electromagnetic Compatibility EN 50270

VI. DETAIL SPECIFICATIONS FOR USE

1. Special precautions

- Sensors are sensitive to some poisons that may cause their desensitisation: emanation of siliconized vapours with concentrations > 10 ppm, chlorinated species or sulphur with concentrations > 100 ppm
- The lack of oxygen (< 15% O₂) or over-oxygenation (> 23% O₂) may cause an underestimation or overestimation of the measurement.

2. Reactions to other combustible gases

It is recommended to calibrate the detector with the gas to be measured. When the user wishes to calibrate it with another gas than that detected and factory programmed, refer to the table below, using the recommended gas and corresponding coefficient.

Table 1: COEFFICIENTS FOR CALIBRATION

	Empirical formula	LEL	LSE	Vapour density	Coefficient CH ₄	Coefficient H ₂	Coefficient But
Butane	C ₄ H ₁₀	1.5%	8.5 %	2	1.75	1.25	1.0
Hydrogen	H ₂	4.0%	75.6%	0.069	1.25	1.0	0.8
Methane	CH ₄	5.0%	15.0%	0.55	1.0	0.75	0.55
Propane	C ₃ H ₈	2.0%	9.5	1.6	1.5	1.1	0.85
Gas recommended for the calibration.							

Example (first line in the table): calibration of a “Acetone” detector with a calibration gas of 1% butane volume

Value to be displayed: $\frac{1\% \text{ (injected butane)}}{1.5\% \text{ (LEL butane)}} \times 100 \times 0.95 \text{ (butane/acetone coefficient)} = 63\% \text{ LEL}$

Note:

- LEL varies based on sources. Those reported here are required by European standard EN 50054.
- The coefficients are accurate at ± 15%

VII. DECLARATIONS OF CONFORMITY



DECLARATION UE DE CONFORMITE EU Declaration of Conformity



La société **Oldham Simtronics S.A.S.**, ZI Est 62000 Arras France, atteste que le
Oldham Simtronics S.A.S. company, *ZI Est 62000 Arras France*, declares that the

Détecteur de gaz (Gas detector) 10 Series
Type OLC(T) 10 (N) CAT, IR, TOX, SC

Versions non Atex (non Atex Versions)

est conforme aux exigences des Directives Européennes suivantes (*complies with the requirements of the following European Directives*):

D) Directive Européenne CEM 2014/30/UE du 26/02/14: Compatibilité Electromagnétique
(2014/308/UE EMC European Directive dated from 26/02/2014: Electromagnetic compatibility)

Norme harmonisée appliquée :
(Harmonised European standard)

EN 50270 : 2015 (Type 2)

Arras, le 18/12/2019 (*December 18th, 2019*)

AM. Dassonville
Certification Responsible

Oldham Simtronics S.A.S.
Z.I. EST - C.S. 20417
62027 ARRAS Cedex – FRANCE
Tel. : +33(0)3 21 60 80 80
www.teledynegasandflamedetection.com

Pour toute intervention de notre Service Après-Vente en France, contactez-nous gratuitement par téléphone au **0 800 653 426** (choix n°1) ou par email à oldham-servicecenter@mmm.com.

