

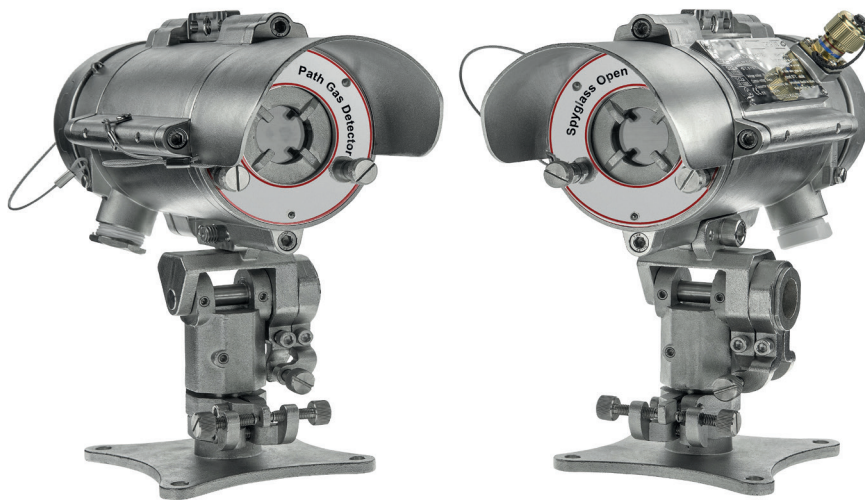

## Spyglass

Open Path Combustible Gas Detector



### Description

The Spyglass Open Path Detector is an innovative, next generation solution to open path combustible gas detection. It can replace multiple point detectors, detects multiple gases at once, and is durable, proving to be a smart, cost efficient choice for combustible gas detection.

### Features

- Three color LED gives a quick visual of unit status
- Intrinsically Safe communication port can be used with HART® Hand-Held in non-safe areas for setup and diagnostics
- Heated optics provide unfettered Detection in most environments
- Long Range reduces number of units required
- Fast response (< 3 seconds) gives quick alert to hazards
- Low maintenance requirements saves time and money
- Multiple regulatory approvals
- Connects easily to existing systems
- User programmable functions allow customization
- Event recorder keeps track of all alerts and warnings
- High reliability and a three-year warranty provide peace of mind



# Spyglass

Open Path Combustible Gas Detector

## Reliable open path gas detection

Long range, fast detection and lower cost of ownership



### Save costs in line-of-sight applications

One Spyglass Open Path Detector can replace up to 20 point combustible gas detectors in line-of-sight applications, saving installation and ongoing maintenance costs. With the Spyglass there are only two units to service and the maintenance requirements are minimized compared with point detectors. Additionally, there is only one consumable to replace periodically; Spyglass Xenon Flash Bulb has a 10 year warranty.

### Detect multiple combustible gases simultaneously

The Spyglass IR sensor can detect multiple combustible hydrocarbon gases at the same time—perfect for facilities with multiple hydrocarbon gases to monitor, such as C1-C8 hydrocarbons (Methane, Ethane, Ethylene, Propane, Propylene, n-butane, Isobutane, 1, 3-butadiene, Isobutylene, Alkanes, Alkenes, Naphthenes, Benzenes).

### Handle tough environments with confidence, longer

Robustly designed to handle the toughest work environments and maintain a long operating life, the Spyglass Open Path Gas Detector is equipped with 316L stainless steel casings and mounts, coated circuit boards for protection, and is SIL-2 approved per IEC61508. Additionally, the Spyglass detector meets MIL-C-810C standards for humidity, salt, fog, vibration, mechanical shock and temperature extremes, while the housings meet IP66, IP68 and NEMA 250 6P water and dust egress standards.

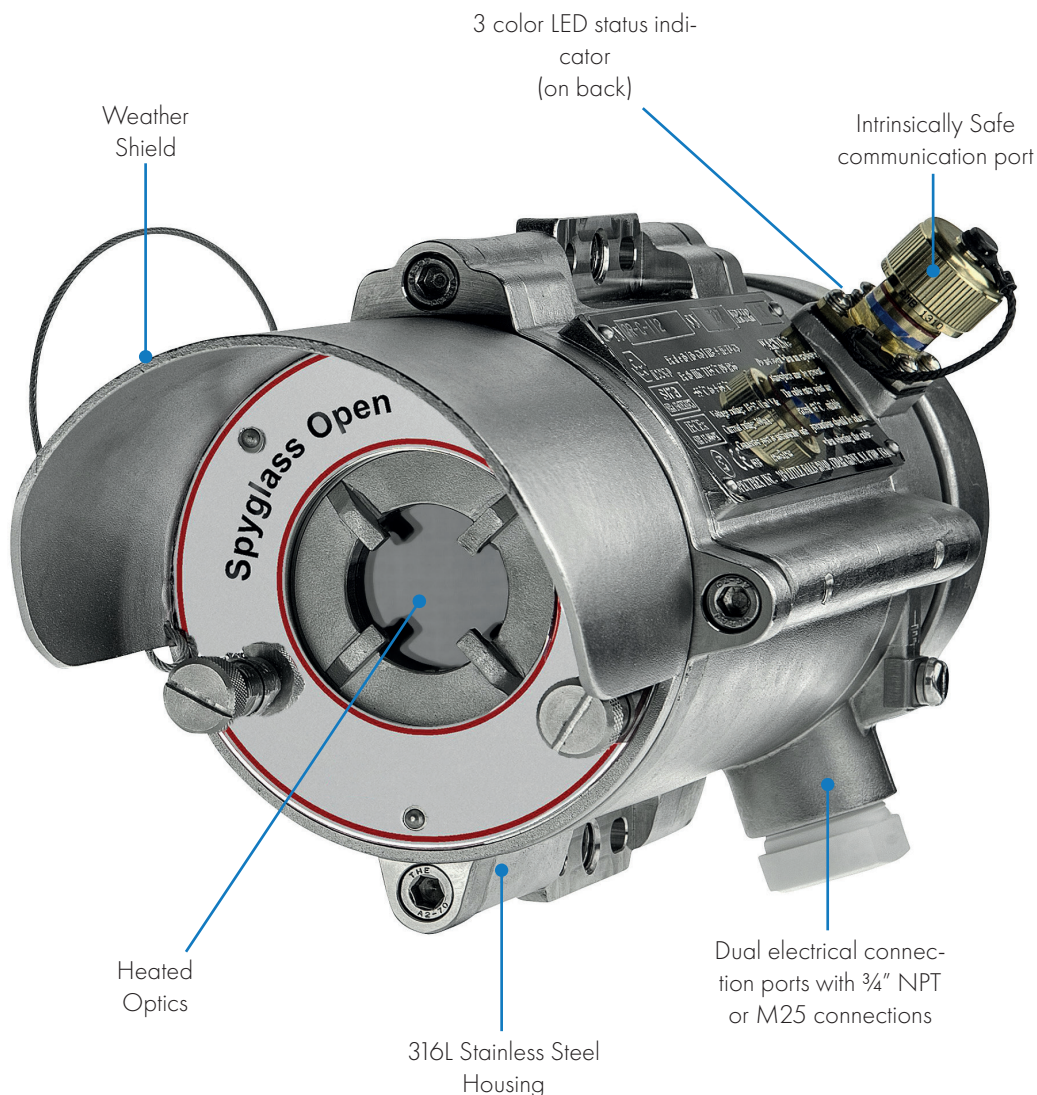

### Accessories



**Commissioning Kit**  
PN 8000449

Commissioning kit includes:  
Alignment Telescope, Magnetic  
Mode Selector, Function Check  
Filters and  
socket keys.



**USB/RS485  
Harness**  
PN 8000453

Connect to your PC to adjust  
detector settings. Only for use  
in Safe Areas.



**HART® Hand-Held  
Communicator Kit**  
PN 8000451

Tool to connect to the detector  
to view, change and maintain  
settings.



# Spyglass

## Open Path Combustible Gas Detector

While we may be more well-known for its long history in the fire safety industry, it has also proudly served the gas detection and protection industry for over 50 years. The new Spyglass Open Path Detector is part of the newest generation of gas detection equipment, proving to be yet another smart solution innovatively designed with customer needs and safety as first priority, always.

## Specifications and ordering information

### Product Specifications

Detector /Source with Tilt Mount Dimensions (each)  
10.5 x 11.4 x 5.1 inch (267 x 288 x 130 mm)

Detector/Source with Tilt Mount Weight (each)  
15.3 lbs (6.9 kg)

Enclosure and Tilt Mount Material  
316L Stainless Steel

Operating Temperature Range / Humidity  
-67°F to 149°F  
-55°C to 65°C  
0 – 95% RH (non condensing)

Minimal Detectable Gas Level  
0.15 LEL.m

Communication  
4-20 mA, MODBUS®, HART®

Enclosure Ingress Protection  
NEMA 250 6P, IP66/IP68

Electrical Connections  
3 or 4 wire connections  
10 – 32 VDC  
6 Watts Max per unit

Electromagnetic Compatibility  
EMI/RFI protected per EN50270

### Approvals

**ATEX/IECEx:**  II 2(2)G D, Ex d e i b [ib Gb] IIB+H<sub>2</sub> T4 Gb, Ex tb IIIC T135°C Db, Ta = -55°C to +65°C

**FM/FMC:** Class I Div 1 Groups BCD, Class II Div I Groups EFG, Class III

**DNV:** Type Approval Certification  
Certificate No. A-13607

### Spyglass Open Path Detector Kits

8000481	Spyglass Model 20 (7-20 m Range), ATEX, M25
8000482	Spyglass Model 20 (7-20 m Range), ATEX, 3/4" NPT
8000483	Spyglass Model 20 (7-20 m Range), FM, M25
8000484	Spyglass Model 20 (7-20 m Range), FM, 3/4" NPT
8000485	Spyglass Model 40 (15-40 m Range), ATEX, M25
8000486	Spyglass Model 40 (15-40 m Range), ATEX, 3/4" NPT
8000487	Spyglass Model 40 (15-40 m Range), FM, M25
8000488	Spyglass Model 40 (15-40 m Range), FM, 3/4" NPT
8000489	Spyglass Model 100 (35-100 m Range), ATEX, M25
8000490	Spyglass Model 100 (35-100 m Range), ATEX, 3/4" NPT
8000491	Spyglass Model 100 (35-100 m Range), FM, M25
8000492	Spyglass Model 100 (35-100 m Range), FM, 3/4" NPT
8000493	Spyglass Model 200 (80-200 m Range), ATEX, M25
8000494	Spyglass Model 200 (80-200 m Range), ATEX, 3/4" NPT
8000495	Spyglass Model 200 (80-200 m Range), FM, M25
8000496	Spyglass Model 200 (80-200 m Range), FM, 3/4" NPT

Each kit contains source, detector and two Tilt Mounts.

### Spyglass Accessories

8000447	Tilt Mount
8000448	Pole Mount (U-Bolt 5 inch)
8000449	Commissioning Kit
8000451	HART Hand-Held Diagnostic Unit
8000452	HART Hand-Held Harness Kit
8000453	USB/RS485 Harness Converter Kit
8000455	Sunshade, Stainless Steel
8000456	Telescope Kit
8000457	Function Check Filter Warning Level - Methane
8000458	Function Check Filter Alarm Level - Methane
8000459	Function Check Filter Warning Level - Propane
8000460	Function Check Filter Alarm Level - Propane
8000497	Magnetic Mode Selector



**AMERICAS**  
4055 Technology Forest Blvd.  
The Woodlands, Texas USA.  
TX 77381  
Tel.: +1-713-559-9200  
Fax: +1-713-893-6729

**EMEA**  
ZI Est, Rue Orfila,  
CS 20417  
62027 ARRAS CEDEX, France  
Tel.: +33-3-21-60-80-80  
Fax: +33-3-21-60-80-00

**ASIA PACIFIC**  
290 Guiqiao Road  
Pudong, Shanghai 201206  
People's Republic of China  
Tel.: +86-21-3127-6373  
Fax: +86-21-3127-6365