

Cole-Parmer[®]

INC-200 Series Incubators

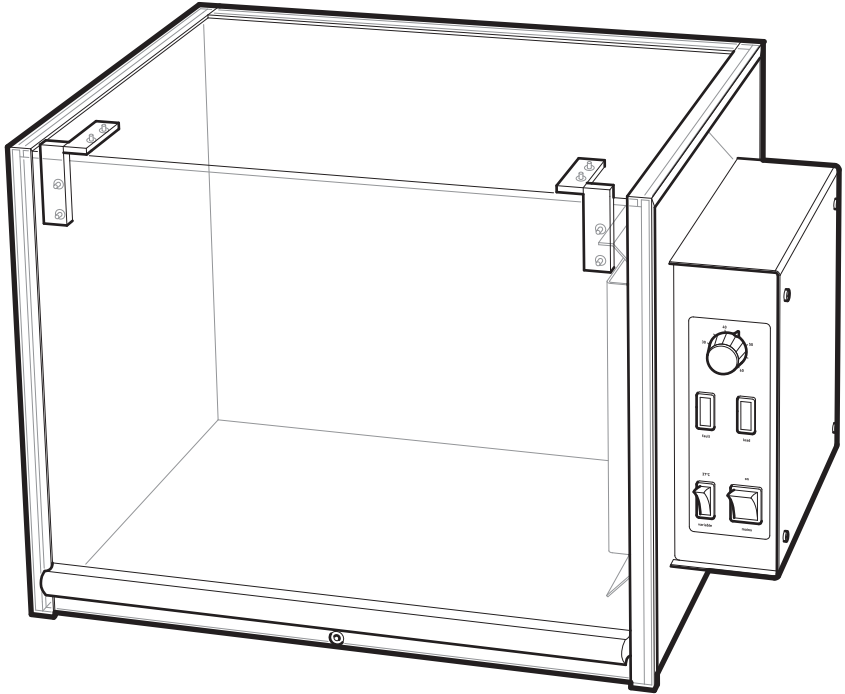

Instruction Manual
ISI60C5(S) Version 1.3

Cole-Parmer[®]
essentials

Introduction

Thank you for purchasing this piece of Cole-Parmer equipment. To get the best performance from the equipment and for your own safety, please read these instructions carefully before use. Before discarding the packaging check that all parts are present and correct.

This equipment is designed to operate under the following conditions:

- ❖ For indoor use only
- ❖ Use in a well ventilated area
- ❖ Ambient temperature range +5°C to +40°C
- ❖ Altitude to 2000m
- ❖ Relative humidity not exceeding 80%
- ❖ Mains supply fluctuation not exceeding 10%
- ❖ Over-voltage category II IEC60364-4-443
- ❖ Pollution degree 2

If the equipment is not used in the manner described in this manual and with accessories other than those recommended by Antylia Scientific, the protection provided may be impaired.



Electrical Installation

THIS EQUIPMENT MUST BE EARTHED

Before connection please ensure that the line supply corresponds to that shown on the rating plate.

Model	Supply requirements	Power
INC-200	220-240V, 50Hz	350W
INC-200D	220-240V, 50Hz	350W

All models are supplied with two mains leads fitted with IEC plugs for connection to the instrument. One has a U.K. 3 pin plug and the other has a 2 pin "Schuko" plug for connection to the mains. Choose the lead appropriate for your electrical installation and discard the other. Should neither lead be suitable, take the lead with the U.K. plug and replace the plug with a suitable alternative. This involves cutting off the moulded plug, preparing the cable and connecting to the re-wireable plug in accordance with its instructions.

THIS OPERATION SHOULD ONLY BE UNDERTAKEN BY A QUALIFIED ELECTRICIAN

NOTE: Refer to the equipment's rating plate to ensure that the plug and fusing are suitable for the voltage and wattage stated.

The wires in the mains cable are coloured as follows:

- BROWN - LIVE
- BLUE - NEUTRAL
- GREEN/YELLOW - EARTH

The instruments are fitted with an IEC socket at the rear of the instrument for connection of the mains lead. The appropriate mains lead should be connected BEFORE connection to the mains supply.

Should the mains lead need replacement, a cable of 1mm² of harmonised code H05W-F connected to an IEC320 plug should be used.

IF IN DOUBT CONSULT A QUALIFIED ELECTRICIAN

Safety Advice Before Use

- ❖ The unit should be carried with both hands, with fingers under each side of the frame.
- ❖ Never move or carry the unit while it is in use or connected to the mains supply.
- ❖ Do not mix flammable liquids or use the equipment in hazardous atmospheres.
- ❖ In case of mains interruption, a fault or mechanical failure, the unit will continue to operate on removal of fault.
- ❖ Mechanical energy can lead to breakage of glass vessels. Use with care.
- ❖ Do not position the unit such that it is difficult to disconnect it from the mains by removing the mains cable from the socket at the back.



USE CAUTION WHEN REMOVING VESSELS FROM THE INCUBATOR AS PARTS MAY BE HOT.

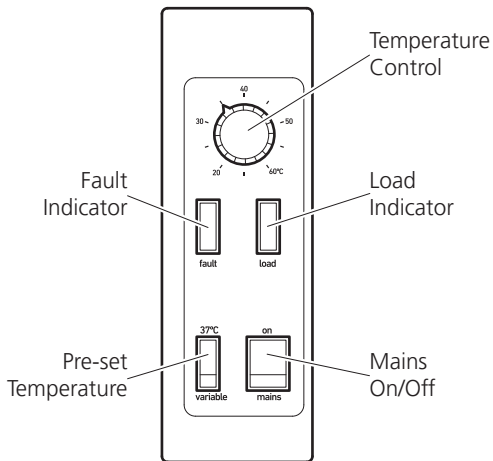

Figure 1: INC-200 controls

General Description

The INC-200 and INC-200D incubators are constructed from clear acrylic material for total visibility. The units are designed for easy access with a hinged front door panel. Each side panel has 2 x 10mm diameter plugged holes for the introduction of either gases or cables. The incubator does not have a base so that it can be placed directly over complete instruments (an optional base and shelving system are available as accessories).

The interior temperature is controllable up to 60°C; forced air circulation and electronic temperature control ensure accurately maintained conditions. Additionally there is a temperature safety cut-out set at 72°C.

The INC-200 has an analogue controller while the INC-200D has a digital display system. In addition to the main temperature selector there is a push switch temperature re-set which maintains the incubator at 37°C.

Controls

Refer to Figures 1 & 2 to identify the controls.

Mains On/Off: This is a rocker-type switch. Pressing the top switches the power on and pressing the bottom switches the power off. The switch is illuminated when the unit is on.

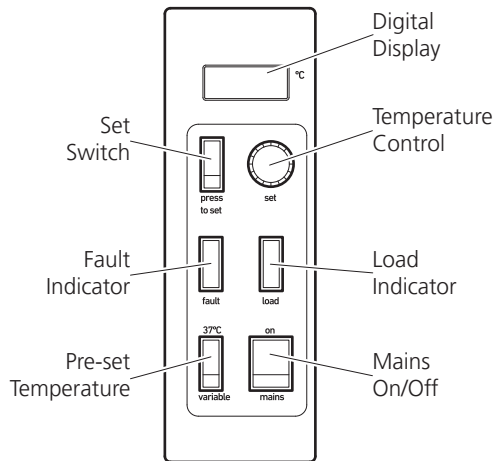

Figure 2: INC-200D controls

Pre-set Temperature Switch: This is a rocker-type switch. Pressing the top switches the incubator to the pre-set temperature (37°C). Pressing the bottom switches the incubator to the variable setting.

Load Indicator: An amber LED illuminates when the heater is in operation. This light remains on while the incubator is reaching the set temperature and flashes when the set temperature is reached.

Fault Indicator: This is a red warning light. When lit it indicates a fault has occurred and the temperature safety cut-off has been initiated (set at 72°C).

Set Switch: This is a plain colour rocker switch. Pressing and holding the switch down displays the set temperature.

Temperature Control: This knob is used to set the temperature of the incubator in conjunction with the press to set switch.

Digital L.C.D.: This is used to display both the actual and set temperature of the incubator in °C. The range is ambient +5°C - 60°C with a resolution of 0.1°C (INC-200D only)

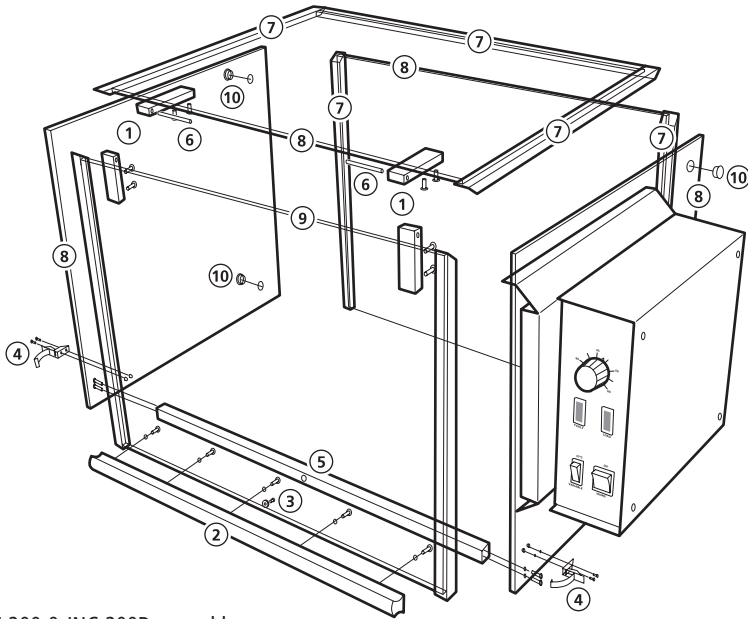

Figure 3: INC-200 & INC-200D assembly

Assembly

Refer to Figure 1

1. Fasten the 4 hinge bars to panels using x2 M4 screws to each hinge component. Do not tighten at this stage.
2. Attach the handle to front door using x5 M4 screws.
3. Screw the countersunk metal screw and washer into the bottom of the front panel.
4. Connect the 2 door clips to the front of the side panels with x2 M3 screws and x2 dome nuts for each clip.
5. Fasten the tie bar with x2 M4 screws at each end. The unit should now be free standing with the tie bar supporting the 2 end units.
6. Insert the hinge bars connecting the front and back panels.
7. Squeeze some silicon compound into the grooves on the back and top panel so when assembled a good seal is formed.
8. Insert two side panels into back panel. Then place top panel into position.
9. Attach door panel to top panel via hinges.
10. Insert the 4 plugs into the holes on the side panels.
11. Finally, tighten up all the screws, but do not overtighten. Allow the silicon sealant at least 12 hours to dry before use.

List of components

- | | |
|-----|---------------------------------|
| x1 | control panel (right hand side) |
| x1 | door panel |
| x1 | left panel |
| x1 | top panel |
| x1 | back panel |
| x1 | tie bar |
| x1 | door handle |
| x1 | tube of silicon rubber compound |
| x4 | hinges |
| x2 | hinge bars |
| x4 | plugs |
| x2 | door clips |
| x1 | magnet catcher |
| x1 | countersunk screw & washer |
| x4 | dome nuts |
| x4 | M3 screws |
| x17 | M4 screws |

Operation

1. Position the apparatus on a firm level surface away from any heat sensitive material and switch the unit ON.
2. If an incubation temperature of 37°C is required, press the pre-set temperature switch to the top.
3. If another incubation temperature is required, press the pre-set temperature switch to the bottom (variable) and set the temperature as follows:

INC-200: Turn the temperature control knob clockwise to the desired setting. The load indicator will remain lit until the desired temperature setting is reached at which time it will flash.

INC-200D: De-press and hold the press to set switch and turn the temperature control knob until the desired temperature appears on the display. On releasing the switch, the display will revert to the actual temperature of the incubator. The load indicator will remain lit until the desired temperature setting is reached at which time it will flash.

Only spare parts supplied or specified by Antylia Scientific or its agents should be used. Fitting of non-approved parts may affect the performance of the safety features designed into the instrument. If in any doubt, please contact the Service Department of Antylia Scientific or the point of sale.

For any other technical enquiries, please contact the Technical Support Department:
Email: cptechsupport@antylia.com
Tel: +44 (0)1785 810433.

Spares and Accessories

Description	Catalogue Number
Fuse 3.15AL	ESM3C 15(S)
Thermal Fuse	ESI6020(S)
Potentiometer and Lead	T55
Transformer	T45(S)
Heater	HSI6005(S)
Base Plate	SI60/1
Shelf System	SI60/2
Gauntlet Front Panel	SI60/3
Gauntlet (per pair)	SI60/4
Tray	SI60/5

Maintenance & Servicing



WARNING: Ensure the unit is disconnected from the mains electricity supply before attempting maintenance or servicing.

Periodically clean the instrument using a damp cloth and mild detergent solution. Do not use harsh or abrasive cleaning agents.

Any repairs or replacement of parts **MUST** be undertaken by suitably qualified personnel.

For a comprehensive list of parts required by service engineers conducting internal repairs, please contact the Service Department, quoting both the model number and serial number:

Email: cpservice@antylia.com
Tel: +44 (0)1785 810475

Technical Specification

INC-200 & INC-200D

Temperature range	Ambient +5°C to 60°C
Temperature fluctuation at 37°C	±0.1°C
Temperature variation between shelves	±0.3°C
Nominal volume	60 litres
Internal dimensions (w x d x h)	450 x 380 x 380mm
External Dimensions (w x d x h)	600 x 390 x 390mm
Net Weight	11.2kg
Electrical supply	230V, 50Hz, 50W



This product meets the applicable CE Directives and UKCA Legislation for radio frequency interference and may be expected not to interfere with, or be affected by, other equipment with similar qualifications. We cannot be sure that other equipment used in its vicinity will meet these standards and so we cannot guarantee

that interference will not occur in practise. Where there is a possibility that injury, damage or loss might occur if equipment malfunctions due to radio frequency interference, or for general advise before use, contact the manufacturer.

Declaration of Conformity is also available to view online at www.stuart-equipment.com

EU Representative address

Antylia Scientific GmbH
Futtererstraße 16
97877 Wertheim
Deutschland
Tel: +49 9377 9203-0
Email: sales@coleparmer.de

UK Representative address

Antylia Scientific
9 Orion Court
Ambuscade Road
Colmworth Business Park
St. Neots
PE19 8YX
United Kingdom
Tel: +44 (0) 1480 277339
Email: enquiries@antylia.com

Ordering Information

Order No.	Series	Model	Legacy SKU
01110-00	INC-200	INC-200-120	SI60/120V/60
01110-02	INC-200	INC-200	SI60
01110-04	INC-200	INC-200D-120	SI60D/120V/60
01110-08	INC-200	INC-200D	SI60D

Warranty Registration



UK

T: +44 (0) 1480 272279
E: uk.sales@antylia.com
W: coleparmer.co.uk

India

T: +9122 61394444
E: info@coleparmer.in
W: coleparmer.in

Germany

T: +49 (0) 9377 92030
E: de.sales@antylia.com
W: coleparmer.de

China

T: +1 847 549 7600
E: sales@antylia.com
W: coleparmer.com

France

T: +33 (0) 1486 37800
E: fr.sales@antylia.com
W: coleparmer.fr

USA

T: +1 847 549 7600
E: sales@antylia.com
W: coleparmer.com

Italy

T: +39 (0) 284349215
E: it.sales@antylia.com
W: coleparmer.it

Canada

T: +514 355 6100
E: info@antylia.ca
W: coleparmer.ca

Other

T: +1 847 549 7600

Cole-Parmer[®]
essentials

Antylia Scientific Ltd.

Beacon Road,
Stone,
Staffordshire,
ST15 0SA,
United Kingdom

