



**TELEDYNE**  
**OLDHAM SIMTRONICS**  
Everywhereyoulook™

# MX32v2

ANALOG AND DIGITAL CONTROLLER



User Manuals in other languages are available on Website  
<https://teledynegasandflamedetection.com>



Copyright © January 2021 by TELEDYNE OLDHAM SIMTRONICS S.A.S. All rights reserved.  
The reproduction of all or any section of this document in any form whatsoever without the  
written permission of TELEDYNE OLDHAM SIMTRONICS S.A.S. is forbidden.

The information contained in this manual is accurate to our knowledge. As a result of continuous  
research and development, the specifications of this product may be modified at any time  
without prior notice.

TELEDYNE OLDHAM SIMTRONICS S.A.S.

Rue Orfila

Z.I. Est – CS 20417

62027 ARRAS Cedex

# Table of contents

1	General Information.....	1
1.1	User Manual.....	1
1.2	Symbols used.....	1
1.3	Safety Instructions.....	2
1.4	Important Information .....	2
1.5	Liability Limits .....	3
1.6	Warranty.....	3
2	General Introduction .....	5
2.1	Purpose of the MX32v2 controller .....	5
2.2	The different Versions.....	7
2.3	Firmpate .....	8
2.4	The COM 32 Software.....	8
3	Mechanical Installation .....	9
3.1	MX32v2 Controller .....	9
3.2	Gas detectors .....	10
3.3	Digital Modules.....	10
4	The MX32v2 Controller.....	11
4.1	Overview of the Unit.....	11
4.2	Front Plate .....	15
4.3	Alarm Thresholds and Relays .....	17
4.4	Firmpate .....	19
5	Digital Modules.....	21
5.1	Addressable Digital Modules.....	21
5.2	RS485 Transmission.....	22
5.3	Communication Setup.....	22
5.4	Relay modules .....	24
5.5	16-Logic Input Module .....	26

5.6	8-Analog Input Module.....	28
5.7	4-Analog Output Module.....	30
6	Wiring and Electrical Connections.....	33
6.1	Controller Connection.....	33
6.2	4- or 8-Relay Modules.....	37
6.3	16-Logic Input Module.....	37
6.4	8-Analog Input Module.....	38
6.5	4 Analog Output Module.....	39
7	Menus.....	41
7.1	General Menu Tree.....	41
7.2	Navigation Key Functions.....	42
7.3	Display in normal mode.....	42
7.4	Main Menu.....	44
7.5	System.....	44
7.6	Program.....	45
7.7	Calibration.....	45
7.8	4. Maintenance.....	49
7.9	5. Information.....	50
8	Main Part Numbers.....	55
9	Cleaning and maintenance.....	57
9.1	Cleaning.....	57
9.2	Fuse replacement.....	57
9.3	Replacement of the lithium battery.....	57
10	Certificate of Compliance.....	59
11	Technical Specifications.....	63
11.1	MX32v2 Controller.....	63
11.2	Relay Module.....	66
11.3	16-Logic Input Module.....	66
11.4	8-Analog Input Module.....	67
11.5	4-Analog Output Module.....	67
12	RS485 Digital Output.....	69

12.1	Card description.....	69
12.2	Transfer Table .....	70
12.3	Address Table.....	71
13	Specific conditions of use and Functional Safety .....	77
13.1	Reliability data.....	77
13.2	Specific Conditions of Use .....	77
13.3	Specific Conditions of Use for FM.....	78
13.4	Specific instructions for the prevention of explosions according to ATEX 2014/34/EU European Directive .....	78

# **MX32v2**

ANALOG AND DIGITAL CONTROLLER  
USER MANUAL

# 1 General Information



**WARNING: ALL INDIVIDUALS WHO HAVE OR WILL HAVE RESPONSIBILITY FOR USING, MAINTAINING, OR SERVICING THIS PRODUCT MUST READ THIS ENTIRE MANUAL CAREFULLY. FAILURE TO USE THIS EQUIPMENT PROPERLY COULD RESULT IN SERIOUS INJURY OR DEATH.**

## 1.1 User Manual

The instructions given in this manual must be read thoroughly before installation and start-up, particularly those concerning the points related to the safety of the end-user. This user manual must be made available to every person involved in the activation, use, maintenance, and repair of the unit.



The information, technical data, and diagrams contained in this manual are based on the information that is available at a given time. In case of doubt, contact *TELEDYNE OLDHAM SIMTRONICS* for additional information.

The aim of this manual is to supply simple and accurate information to the user. *TELEDYNE OLDHAM SIMTRONICS* cannot be held liable for any misinterpretations in the reading of this manual. In spite of our efforts to produce an error-free manual, it may nonetheless contain some unintentional technical inaccuracies.

In the client's interest, *TELEDYNE OLDHAM SIMTRONICS* reserves the right to modify the technical characteristics of its equipment to increase their performance without prior notice. The present instructions and their content are the inalienable property of *TELEDYNE OLDHAM SIMTRONICS*.

## 1.2 Symbols used

Icon	Significance
	This symbol indicates useful additional information.
	This symbol indicates: Earth ground connection.
	This symbol denotes: Protective earth terminal. A cable of the adequate diameter must be connected to ground and to the terminal having this symbol.

Icon	Significance
	This symbol denotes: <b>Attention! In the present mode of use, failure to adhere to the instructions preceded by this symbol can result in a risk of electric shock and/or death.</b>
	This symbol indicates: You must refer to the instructions.
	European Union (and EEA) only. This symbol indicates that this product must not be discarded with household waste, as per the EEA directive (2002/96/EC) and your own national regulations.  This product must be disposed of at a collection point that is reserved for this purpose, for example, an official site for the collection of electrical and electronic equipment (EEE) in view of their recycling, or a point of exchange for authorized products that is accessible when you acquire a new product of the same type.

## 1.3 Safety Instructions

Labels intended to remind you of the principal precautions of use have been placed on the unit in the form of pictograms. These labels are considered an integral part of the unit. If a label falls off or becomes illegible, please ensure it is replaced. The significance of the labels is detailed below.



The installation and electrical connections must be carried out by qualified personnel according to the instructions of the manufacturer and the standards of the competent authorities. Failure to adhere to the instructions can have serious consequences on the safety of persons. Please be extremely rigorous as regards electricity and assembly (coupling, network connections).

Cables with an operating temperature of 70°C minimum (158 °F) must be used because the temperature inside the controller can reach 70°C (158 °F).

## 1.4 Important Information

The modification of the material and the use of parts of an unspecified origin shall entail the cancellation of any form of warranty. The use of the unit has been projected for the applications specified in the technical characteristics. Exceeding the indicated values cannot in any case be authorized.



## 1.5 Liability Limits

Neither *TELEDYNE OLDHAM SIMTRONICS* nor any other associated company under any circumstances can be held liable for any damage, including, without limitations, damages for loss or interruption of manufacture, loss of information, defect of the *MX32v2* controller, injuries, loss of time, financial or material loss, or any direct or indirect consequence of loss occurring in the context of the use or impossibility of use of the product, even in the event that *TELEDYNE OLDHAM SIMTRONICS* has been informed of such damage.

## 1.6 Warranty

Under normal conditions of use and on return to the factory, parts and workmanship carry a two year warranty, excluding consumables such as backup power supplies, audio and visible alarms, etc.

# **MX32v2**

ANALOG AND DIGITAL CONTROLLER  
USER MANUAL

## 2 General Introduction

### 2.1 Purpose of the MX32v2 controller

This controller is intended for the continuous measurement and control of the gases present in the atmosphere.

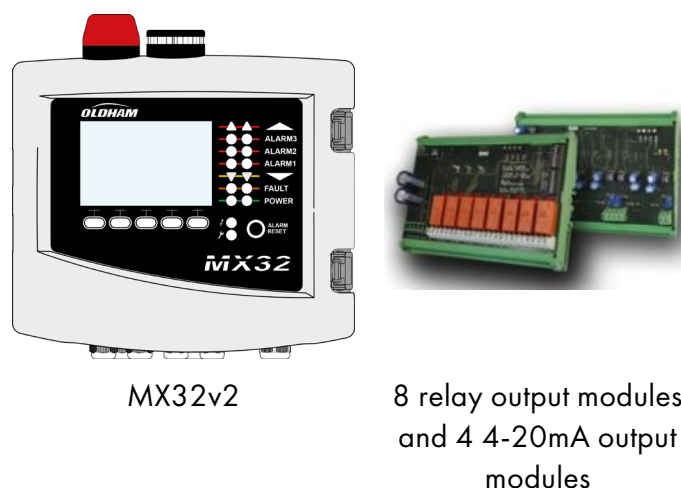

Figure 1: MX32v2 and examples of the modules

The system primarily comprises :

- a MX32v2 (1 or 2 lines),
- different modules (analog or digital detectors, logic inputs, analog inputs, relay outputs, and analog outputs).

The *MX32v2* instantly handles the measurements of detectors and input modules. As soon as the measurements reach the configured thresholds, the internal buzzer and the LED indicators go off. At the same time, the corresponding relays are activated to drive the additional actions programmed by the user. The *MX32v2* controller is programmed by using the *COM 32* configuration software. Figure 2 presents a configuration example.

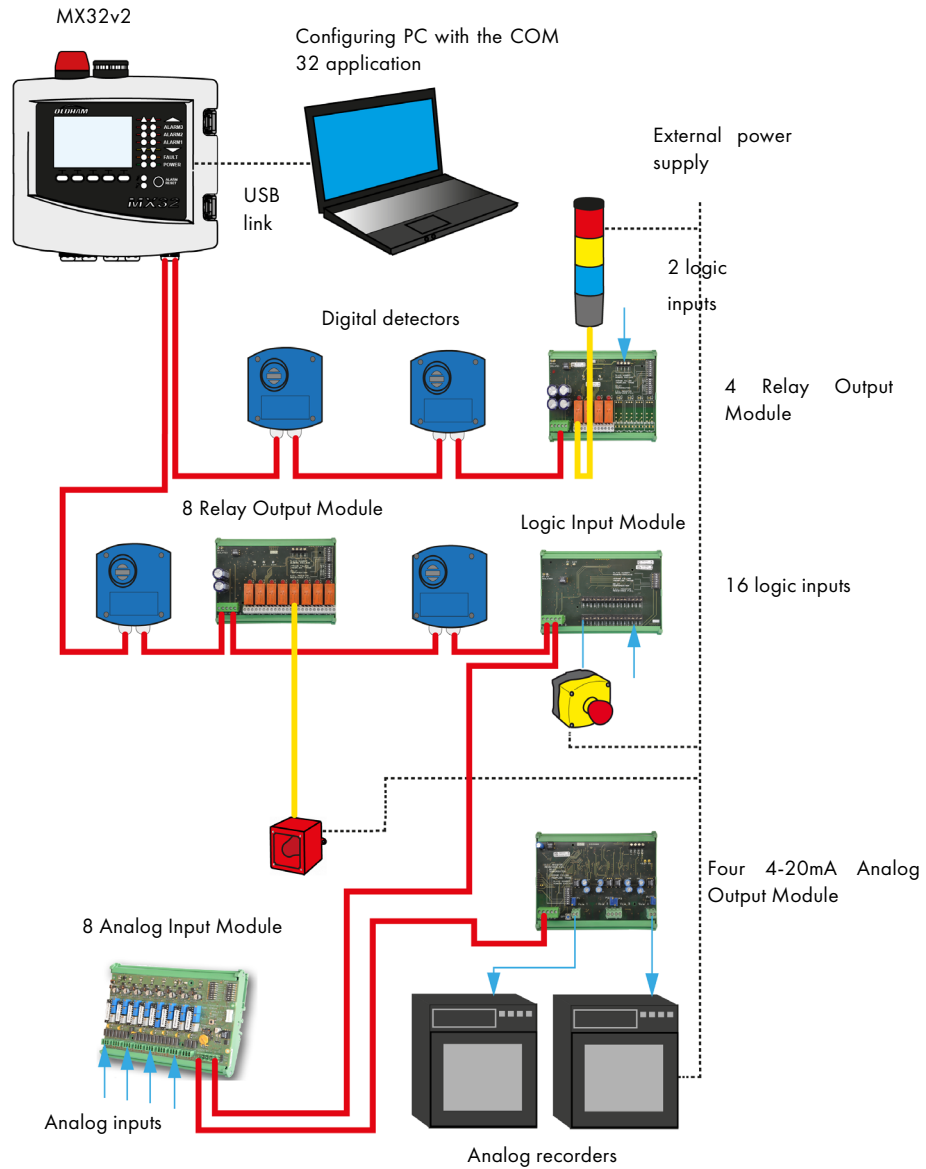

Figure 2: Example of an MX32v2 configuration using different analog and digital detectors as well as digital modules

## 2.2 The different Versions

The MX32v2 controller is available in 3 versions: 1 line,

- 2 lines,
- Bridge Version (2 channels) for direct monitoring of Wheatstone bridge flammable gas detectors.

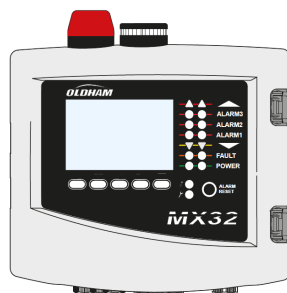

Figure 3: MX32v2

The following table details the different possible configurations depending on the controller's version. On each line, it is possible to connect 4-20mA analog detectors or digital addressable modules.

Version	Maximum Capacity				
	Detectors	Analog Input Modules	Relay Output Modules	Logic Input Modules	Analog Output Modules
1 line	4	1	2	1	1
2 lines	8	2	4	2	2
Wheatstone Bridge	2 <sup>(1)</sup>	0	0	0	0

(1) OLC 10, OLC 10Twin or OLC 100 flammable gas detectors

Version	Maximum Capacity		
	External Relays	Logic Inputs	Analog Outputs
1 line	8	16	4
2 lines	16	16	8
Wheatstone Bridge	0	0	0

Table 1: Summary of the maximum capacity as per the controller type

## 2.3 Firmplate

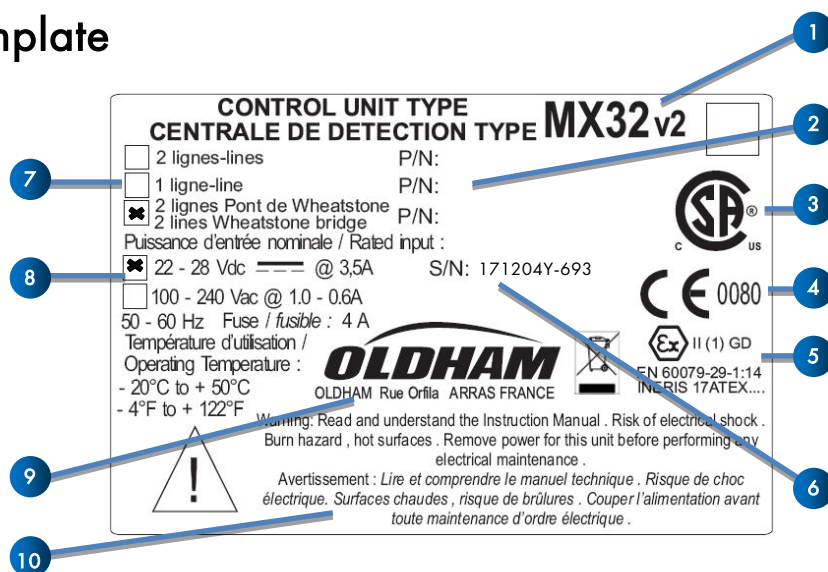

It contains relevant information with respect to the controller version (CSA or ATEX variants).

Tag.	Description
1.	Product Name
2.	Part Number
3.	CSA mark
4.	CE marking with identification of the Notified Body that assessed the TELEDYNE OLDHAM SIMTRONICS manufacturing quality system (0080 - INERIS)
5.	ATEX marking (Performance requirements of gas detection systems for flammable gases)
6.	Serial Number. The first two digits (in this case 17) correspond to the year of manufacture (in this case 2017).
7.	Variant (1 or 2 lines to work with 4-20mA analog detector or TELEDYNE OLDHAM SIMTRONICS digital detector, or 2 channels to work with Wheatstone bridge gas detectors). In this example, version 'Wheatstone Bridge'.
8.	Power supply type (24Vdc or 100-240Vac). In this example, 24Vdc type.
9.	Name and mail address of the Manufacturer
10.	Warnings

## 2.4 The COM 32 Software

This is intended for setting the *MX32v2* parameters from a Windows® operated PC. The operation and use of this application is covered in a special training course.

## 3 Mechanical Installation

### 3.1 MX32v2 Controller

**3.1.1 Location** The *MX32v2* is intended for indoor use only and shall be installed in premises without explosive atmospheres, away from direct exposure to sunlight, and protected from humidity, dust, and temperature variations. It shall preferably be located in a monitored environment (for instance: guardhouse, control room, or instrument room, etc.).

**3.1.2 Attachment of the wall enclosure** Access to the controller must be ensured in order to facilitate adjustments, monitoring, and cabling. A space of 400 mm is necessary in front of the *MX32v2* for opening the door. Use 3 fixing screws 4x25 mm for fixing the case support.

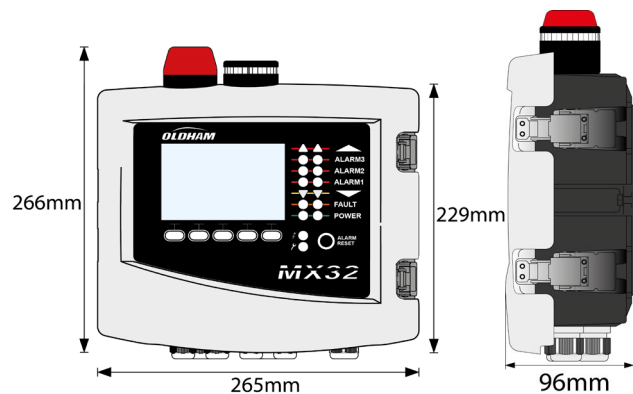

Figure 4: Dimensions

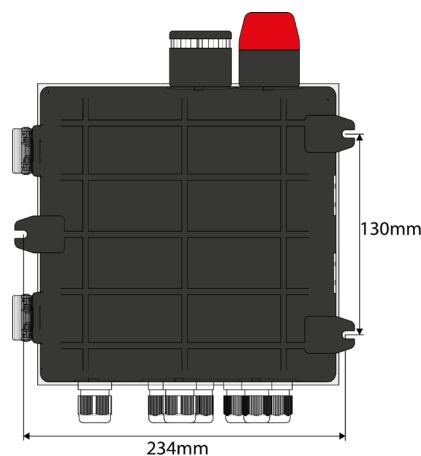

Figure 5: Fixing the *MX32v2*

## 3.2 Gas detectors

---



Refer to the manual supplied with each detector.

---

### 3.2.1 Location

Each detector shall be positioned at ground level, on the ceiling, at human height or near air extraction ducts, depending on the density of the gas to be detected or the application. Heavy gases are detected close to the ground, while lighter gases are present along the ceiling. If necessary, contact *TELEDYNE OLDHAM SIMTRONICS* for any questions regarding proper detector positioning.

### 3.2.2 Fixing

The detectors shall preferably be positioned in an accessible place so that inspections and maintenance can be carried out as well as to ensure the absolute safety of the operators. The detectors must not be obstructed by anything that will prevent them from measuring the ambient environment to be checked.

## 3.3 Digital Modules

---



For cabling and electrical information see paragraph *Wiring and Electrical Connections* on page 33.

---

**Location** The relay modules, logic outputs, analog outputs, and analog inputs are positioned depending on the installation layout, mandatorily in places free from explosive atmospheres, protected from humidity, dust, and temperature variations; for example in technical cabinets.

### Fixing

These modules shall be mounted on a DIN rail in a cabinet or in an electrical cabinet. For relay modules connected to low voltage electrical parts, the installation is carried out according to the standards in force.

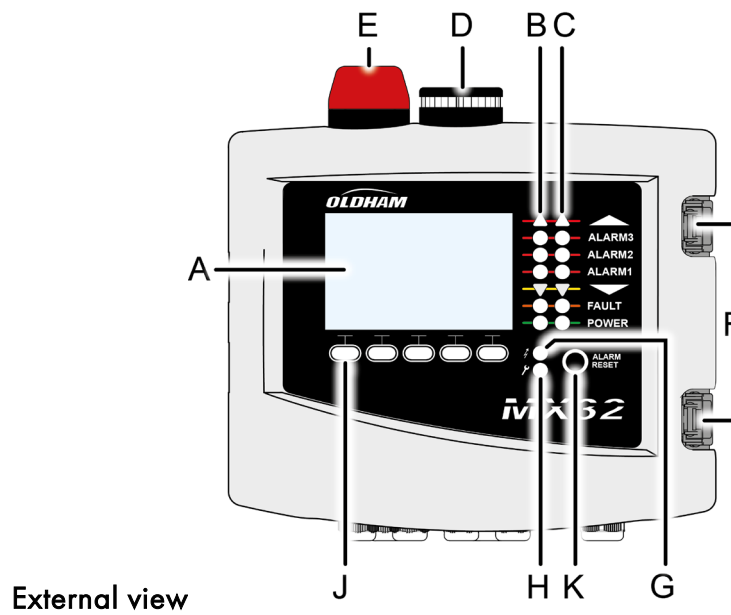

Figure 6: Fixing of a module (relay, logic outputs, or analog outputs or inputs) on a DIN rail



## 4 The MX32v2 Controller

### 4.1 Overview of the Unit



080

Rep.	Function	Rep.	Function
A.	Monochromatic, back-lit graphic LCD display	F.	Toggle Latch (one is lockable)
B.	Zone 1 status indicator	G.	Power On/Off indicator
C.	Zone 2 status indicator	H.	Failure/maintenance indicator
D.	Integrated siren (option)	J.	Contextual soft keys
E.	Integrated flash (optional)	K.	Alarm Acknowledgement button

Figure 7: External view of the wall-mounted and rack-mounted versions

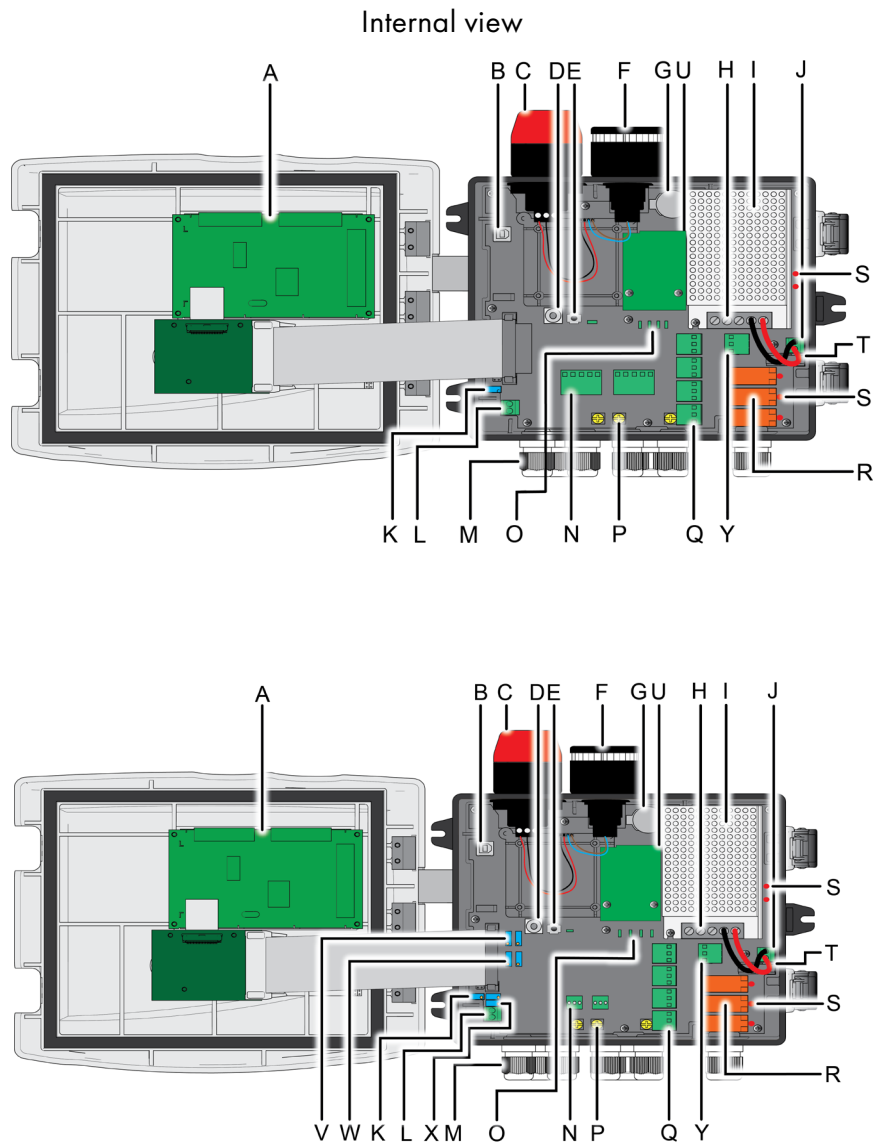



Figure 8: Internal view (2 line version on top and Bridge version at the bottom)

Rep.	Function
A.	LCD graphic display card
B.	USB programming port
C.	On-board additional flashlight (option)
D.	Programming (or mode) selector 0. <i>MX32v2</i> in normal operation. 1. Read/Write configuration program 2. <i>MX32v2</i> firmware update via a PC

Rep.	Function										
	 <p>Once the unit configuration or update is complete, always set back the selector in the "0" position. The <i>MX32v2</i> will resume automatically.</p>										
E.	Microcontroller reset button. Press this button to reset the controller.										
F.	On-board additional siren, settable from 85 to 100dB (option)										
G.	CR2032 lithium battery. Allows data and real time clock saving in case of power failure. Runtime is approx. 450 days while power off. Keep the <i>MX32v2</i> powered during battery replacement.										
H.	100-240Vac (50-60Hz) input terminal										
I	100-240Vac / 24Vdc power supply (option)										
J	22-28Vdc input terminal. Allows the use of an external power supply (read External 24Vdc Power Supply, page 34)										
K.	Display contrast setting										
L.	Remote acknowledgement input terminal (NO dry relay contact)										
M	Cable glands; 5 x M16 + 2 x M20										
N	Line #1 terminal (1 to 2 lines depending on the version)										
O.	Digital communication status LED indicators (Line #1 on left, Line #2 on right). The information displayed by each pair of LEDs is interpreted as follows:										
<table border="1" style="width: 100%; border-collapse: collapse;"> <thead> <tr> <th style="background-color: black; color: white;">LED Status</th> <th style="background-color: black; color: white;">Significance</th> </tr> </thead> <tbody> <tr> <td>Fast blinking      Fast blinking</td> <td>Line is in normal operation mode- Tx: sends queries to the attached modules - Rx: receives data from attached modules</td> </tr> <tr> <td>Irregular blinking      Irregular blinking</td> <td>Bad communication quality with at least one module.</td> </tr> <tr> <td>Blinks 1 time Off per sec</td> <td>Communication failure. Absence or failure of one module  On communication failure, the internal buzzer, the failure indicator and the Fault relay are activated.</td> </tr> <tr> <td>Off                      Off</td> <td>No active module is present on the line</td> </tr> </tbody> </table>		LED Status	Significance	Fast blinking      Fast blinking	Line is in normal operation mode- Tx: sends queries to the attached modules - Rx: receives data from attached modules	Irregular blinking      Irregular blinking	Bad communication quality with at least one module.	Blinks 1 time Off per sec	Communication failure. Absence or failure of one module  On communication failure, the internal buzzer, the failure indicator and the Fault relay are activated.	Off                      Off	No active module is present on the line
LED Status	Significance										
Fast blinking      Fast blinking	Line is in normal operation mode- Tx: sends queries to the attached modules - Rx: receives data from attached modules										
Irregular blinking      Irregular blinking	Bad communication quality with at least one module.										
Blinks 1 time Off per sec	Communication failure. Absence or failure of one module  On communication failure, the internal buzzer, the failure indicator and the Fault relay are activated.										
Off                      Off	No active module is present on the line										
P.	Grounding terminals to connect cable shield for digital and analog connections										
Q	From top to bottom, relay alarm terminals (R1 to R4 respectively). DPCO relays, contacts rating 250Vac-30Vdc / 5A										

Rep.	Function
R.	<p>Fault and Alarms relays (2 relays are located under the power supply; tag 1). From top to bottom:</p> <ul style="list-style-type: none"> <li>• Fault (Fault relay, non-configurable)</li> <li>• R1, R2, R3, R4 (alarm relays, configurable)</li> </ul> <p><b>Configuration of Alarm Relays</b> Alarm relays are to be programmed with <i>COM 32</i> software. The PCB printing displays while unpowered. R1 to R4 relays can be configured as normally energized (the coil is powered when not in alarm) or normally de-energized (the coil is powered when in alarm). There are different way to program the relays:</p> <ul style="list-style-type: none"> <li>• Normal mode: relay operates as the alarm sequence. The sure can set a delay and chose the relay to be latched or unlatched (see Alarm Acknowledgement, page 18).</li> <li>• Buzzer mode: This mode is usually used for audible alarms management. The ‘buzzer’ relay acts as a ‘normal’ relay but can be acknowledged even if the alarm is still present (in order to turn the siren off).</li> </ul> <p>The time delays are:</p> <ul style="list-style-type: none"> <li>. Reset Inhibit: Minimum time of activation, adjustable from 0 to 900 seconds.</li> <li>. Automatic reset: Time adjustable between 15 and 900 seconds, beyond which the buzzer relay is automatically deactivated.</li> <li>. Reactivation time: Time adjustable between 15 and 900 seconds, beyond which the buzzer relay is automatically reactivated if the alarm is still present.</li> </ul> <p><b>Alarm Relay Management</b> by the logic operators OR, AND, NOR, NAND. Up to 4 levels of parentheses. The result of the equation controls the relay.</p> <ul style="list-style-type: none"> <li>• Voting operation (x out of y): There must be at least “x” events out of “y” to activate the relay. Depending on user’s programmation, a FAUT event can be treated as an alarm event.</li> </ul>
S.	Relays status DEL indicator. Illuminated when the corresponding relay coil is ON.
T.	4 Amp fuse, protects the 24V power supply input
U.	Modbus RS485 communication board (option, see page 69)
V.	Zero setting potentiometer (on the left line #1, on the right line #2)
W.	Span setting potentiometer (on the left line #1, on the right line #2)
X.	Catalytic bead current adjustment (top line #1, bottom line #2). Settings are reserved to authorized personel
Y.	Faut relay terminal. DPCO relay, 250Vac-30Vdc / 5A

## 4.2 Front Plate

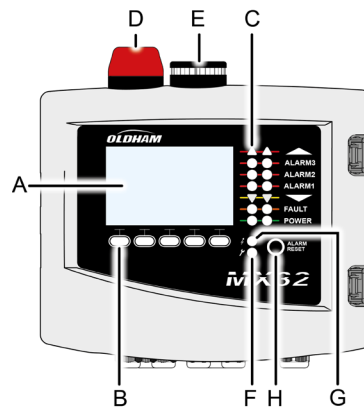

Figure 9: MX32v2's front plate

### 4.2.1 LCD (A)

The display shows the measurements or the settings menus. When an alarm occurs, the display turns in grayscale mode to indicate the channel that is currently displayed is on alarm.

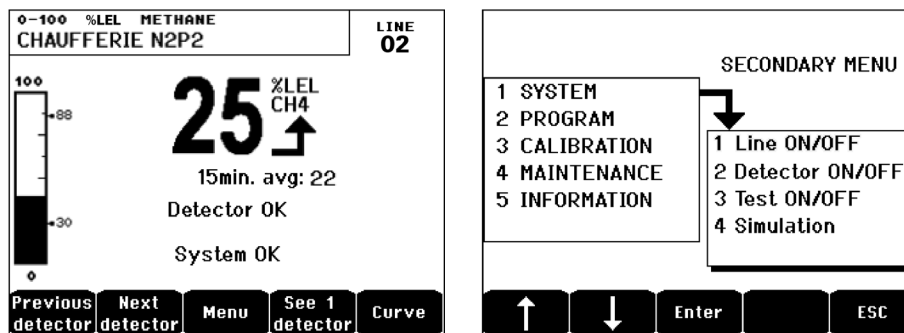

Figure 10: Display of the measurement (on the left) or parameter settings display (on the right)

Refer to paragraph *Menus* on page 41 for more details about the information that are available on the screen.

### 4.2.2 Contextual Keys (B)

The function of each of the 5 keys indicated in the lower part of the display changes depending on the page displayed.

#### Zone Status Indicators (C)

The two bars of 7 indicators represent two zones. The detectors that are connected to the controller can be assigned to one of the two zones by using *COM 32* configuration software.

Each bar displays the status of the group of detectors of the pertinent zone as follows:

Icon	Function
▲	<p>Orange indicator of high-range excess (OVS: overscale, high-range excess). This value is adjustable up to 110% of the range.</p> <ul style="list-style-type: none"> <li>• Off: The measurement is lower than the OVS value programmed.</li> <li>• Lit: The measurement is higher than the OVS value programmed. The alarm relays are activated in accordance with the program. In parallel, the display indicates « &gt; ».</li> </ul> <p>OVS acknowledgement must be done manually and is only possible if the current value drops below the programmed value. <b>Management of "Non-Ambiguity Reading"</b> The <i>Non-Ambiguity Reading</i> function only applies to the monitoring of flammable gases in a range of 0-100%LEL, and is subject to the decision of the operator. Upon the detection of a concentration of gas higher than 100% LEL, the LCD indicates <i>&gt; 100% LEL – Frozen value – High Concentration - System in Fault Condition</i>. The OVS and FAILURE indicators are activated. Such an alarm can only be deactivated by turning off the detector via the maintenance menu once the current gas level is below the programmed OVS limit.</p>
ALARM 3ALARM 2ALARM 1	<p>Alarm status red indicators:- Off: No alarm</p> <p>- Solid: at least one gas detector of the corresponding zone is in alarm condition. Acknowledgment is programmed in automatic mode or the alarm reset button located on the front panel has already been pushed.</p> <p>- Blinking: at least one gas detector of the corresponding zone is in alarm condition. Acknowledgment is programmed in manual mode and has not been required yet.</p>
▼	<p>Orange indicator of low- range excess (UDS: Under scale, low-range excess). This value is adjustable from 0-10% of the range.</p> <ul style="list-style-type: none"> <li>• Off: The measurement is higher than the UDS value programmed.</li> <li>• Lit: The measurement is lower or equal than the UDS value programmed. The alarms of the relays are activated in accordance with the programming. In parallel, the display indicates « &lt; ».</li> </ul> <p>Reset of the UDS is automatic once the failure is fixed.</p>
FAULT	<p>Orange failure indicator Off: No Fault</p> <ul style="list-style-type: none"> <li>• Solid: Communication problem with one of the modules or invalid detector measurement, that is to say either below -10% of the range or above 110% of the range.</li> <li>• Blinking: Controller in maintenance mode (test, calibration).</li> </ul> <p>Reset of the FAULT is automatic once the failure is fixed.</p>

Icon	Function
POWER	Green start/stop indicator for the detectors/modules of the zone. Off: All detectors of the corresponding zone have been turned off <ul style="list-style-type: none"> <li>• Solid: At least one detector of the corresponding zone is communicating</li> <li>• Blinking: Detailed information of one detector of the corresponding zone are currently displayed on the LCD screen.</li> </ul>

### 4.2.4 Flash and siren (D and E)

**Siren** (Figure 9: *MX32v2's* front plate E)



Figure 9: *MX32v2's* front plate Available as an option, adjustable from 85 to 100dB, it complements the internal buzzer and is configured via *COM 32* configuration software.

**Flash** (Figure 9: *MX32v2's* front plate D)

Available as an option, blue or red, is configurable via *COM 32*.

### 4.2.5 Status indicators (F and G)

These two indicators reflect the status of the *MX32v2*.

Icon	Function
	Green indicator denoting the power supply status Solid: Voltage input is OK <ul style="list-style-type: none"> <li>• Off: Voltage input is below 22Vdc</li> </ul>
	Failure/maintenance orange indicator Off: No failure detected <ul style="list-style-type: none"> <li>• Solid: Presence of some failure (controller, detector, communication, memory). The alarm clears automatically once the failure is fixed.</li> <li>• Blinking: <i>MX32v2</i> in maintenance mode (test, calibration).</li> </ul>

### 4.2.6 Alarm Reset Key (H)

Press this key to silence the on-board buzzer and reset the alarms that can be acknowledged. This reset button can be remote, see paragraph *Remote Acknowledgement connector* on page 36.

## 4.3 Alarm Thresholds and Relays

Alarm thresholds, relay programming, time delays setting, alarm acknowledgement modes or the management of the additional flash and sounder (Figure 9: *MX32v2's* front plate tags D and E) are configured through *COM 32* application.

Note: It is possible to modify a programmed alarm level via the *MX32v2's* user interface (*Program* menu).

### 4.3.1 Internal Relays and Buzzer

- Fully configurable Alarm relays are available.
- 1 Fault relay is available. This relay is not configurable and is activated on the appearance of any failure. The Fault relay is powered in normal operation mode so it does switch over in the event of a power supply failure.
- The internal buzzer is activated on the appearance of any event (failure or alarm). The sound differs depending on the event: continuous in fault mode, discontinuous in alarm mode and frequency increases according to the alarm level that is reached. The internal buzzer can be deactivated permanently through the user interface or COM 32 application.

### 4.3.2 Alarms Settings

It is possible to program for each detector: 3 alarm levels

- each alarm can be increasing or decreasing
- each alarm can be configured as an instantaneous alarm and/or an averaged alarm over 15 to 480 minutes
- each alarm has an adjustable hysteresis from 0 to +3% of the measuring range by increments of 1%
- one over range alarm (OVS: over scale)
- one under range alarm (UDS: underscale)
- one "no ambiguity" alarm (for flammable gas detectors and concentrations above 100% LEL)

Alarms may be programmed for automatic or manual acknowledgement (except OVS, UDS, "no ambiguity").

### 4.3.3 Alarms Automatic Acknowledgement

In this mode, resetting an alarm does not require any intervention. Alarm management (relays, visual indicators, buzzer) is as follows:

Event	Display	Alarm Relay (normal mode)	Alarm Relay (buzzer mode)	Alarm LED	Internal buzzer
Alarm Appearance	AL (1,2,3) grayscale mode	Activated	Activated	Solid	ON
<i>Alarm Resets</i> pressed	AL (1,2,3) grayscale mode	Activated	Deactivated	Solid	OFF
Alarm Disappearance	Normal mode	Deactivated <sup>(a)</sup>	Deactivated <sup>(a)</sup>	OFF	(b)



- (a): Automatic deactivation upon alarm disappearance even if Alarm Reset button was not pressed
- (b): Manual acknowledgement (press Alarm Reset) is mandatory to silence the internal buzzer

**Table 2: Alarms in Automatic Acknowledgement mode**

### 4.3.4 Alarms Manual Acknowledgement

In this mode, Alarms must be reset by the operator. Alarm management (relays, visual indicators, buzzer) is as follows:

Event	Display	Alarm Relay (normal mode)	Alarm Relay (buzzer mode)	Alarm LED	Internal buzzer
Alarm Appearance	AL(1,2,3) grayscale mode	Activated	Activated	Blinking	ON
<i>Alarm Resets</i> pressed	AL(1,2,3) grayscale mode	Activated if event is still present	Deactivated	Solid if event is still present	OFF
	AL(1,2,3) grayscale mode	Deactivated if the event has disappeared	Deactivated	OFF if the event has disappeared	OFF
Alarm Disappearance	Normal mode <sup>(a)</sup>	Deactivated <sup>(a)</sup>	Deactivated <sup>(a)</sup>	OFF <sup>(a)</sup>	OFF <sup>(a)</sup>

(a): Once Alarm Reset button has been pressed

**Table 3: Alarms in Manual Acknowledgement mode**

## 4.4 Firmplate

Firmplates are attached on the right side, on the top and behind the front cover of the MX32v2. Following information can be found:

- Model (1 or 2 lines and power supply type)
- Electrical Specifications (power consumption, fuse)
- P/N and S/N
- Warnings and Approval Markings
- Logo and manufacturer’s details

# **MX32v2**

ANALOG AND DIGITAL CONTROLLER  
USER MANUAL

## 5 Digital Modules

This chapter presents the digital modules that may be installed on the MX32v2 lines.



The details of module connection are given on page 33. Digital modules are configured via *COM 32* configuration software.

### 5.1 Addressable Digital Modules

Up to 5 modules can be used with the single line version and up to 10 modules can be used with the 2 line models. The *MX32v2* in bridge version is not compatible with any modules (see Table 1:). The following table lists the available modules:





Type of module	Illustration	Page
4 Output Relay Module with 2 additional logic inputs		24
8 Output Relay Module with 2 additional logic inputs		24
8 Analog Input Module		28
16 Logic Input Module		26
4 Analog Output Module with 2 additional logic inputs		30

Table 4: Addressable digital modules

## 5.2 RS485 Transmission

General Topology of RS 485 Network The digital modules are linked by a two twisted pair shielded cable (4 x 0.22 m<sup>2</sup> minimum, MPI-22A type, nominal impedance 100 Ohms). This cable carries the RS485 signal (A and B) on one pair and the power supply (24Vdc) on the other pair. Shielding continuity must imperatively be carried out between all the modules and the *MX32v2* controller. + 24Vdc, 0V, A, B terminals are respectively connected to +24Vdc, 0V, A, B terminals of the other modules and then to the terminal of the corresponding line on the controller. The cable shield must be connected to the *MX32v2* ground terminal.

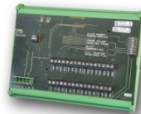
The 120-Ohm end of line resistor (EOL RESISTOR/RESISTANCE F.D.L) must be activated on the last module present on the bus (whatever the last module).



No bare wire should remain apparent. For protection against electromagnetic interference, the shield (or braid) should be cut as short as possible and necessarily connected.

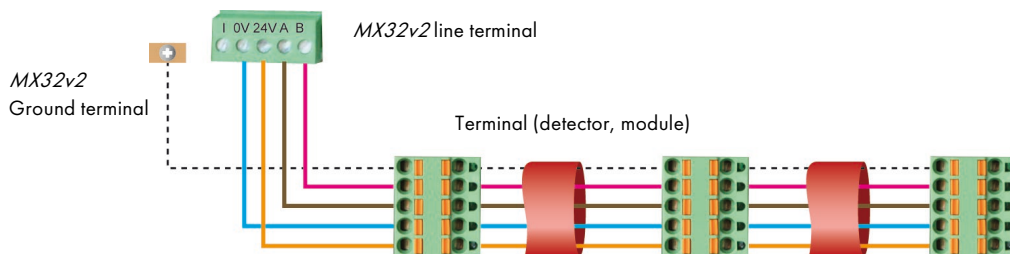

Figure 11: Connection of the modules on a line



The incorrect installation of the cables or cable glands can cause measurement error or system malfunction. Do not run the cables close to equipment such as engines, transformers, or electrical lines generating a strong magnetic field. It is always recommended to ensure a good separation between these cables and the cables of other circuits.

## 5.3 Communication Setup

### Module Address

All digital modules must be identified by a unique address.

On all modules, DIP switches #1 to #5 allow to set the address in binary mode.

In the illustration to the right, address 9 (10010) has been defined.

The Addressing Table below lists the possible combinations.

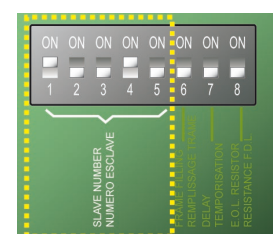

Figure 12: DIP switches for address configuration

Module Address	DIP switches (ON = 1; OFF = 0)				
	1	2	3	4	5
1	1	0	0	0	0
2	0	1	0	0	0
3	1	1	0	0	0
4	0	0	1	0	0
5	1	0	1	0	0
6	0	1	1	0	0
7	1	1	1	0	0
8	0	0	0	1	0
9	1	0	0	1	0
10	0	1	0	1	0
11	1	1	0	1	0
12	0	0	1	1	0
13	1	0	1	1	0
14	0	1	1	1	0
15	1	1	1	1	0
16	0	0	0	0	1

Module Address	DIP switches (ON = 1; OFF = 0)				
	1	2	3	4	5
17	1	0	0	0	1
18	0	1	0	0	1
19	1	1	0	0	1
20	0	0	1	0	1
21	1	0	1	0	1
22	0	1	1	0	1
23	1	1	1	0	1
24	0	0	0	1	1
25	1	0	0	1	1
26	0	1	0	1	1
27	1	1	0	1	1
28	0	0	1	1	1
29	1	0	1	1	1
30	0	1	1	1	1
31	1	1	1	1	1
32	0	0	0	0	0

Table 5: Addressing table (address depends on the position of the switches)

Remarks: The physical address of a module (1 to 32 max) must be identical to the registered address via *COM 32* software configuration.

- When a module has to be replaced, all DIP switches must be configured as the previous module.
- Switch #6 (FRAME FILLING/REPLISS TRAME) must be set to OFF and switch #7 (DELAY/TEMPORISATION) must be set to ON (options unused).

The 8 analog input module systematically monopolizes 8 addresses.

### 5.3.1 End Of Line Resistor

For the last module only of each line, set switch #8 (EOL RESISTOR/RESISTANCE F.D.L.) to ON or set the jumper of the Analog Input Module to *Closed* (Figure 19: 8 Analog Input ModuleN).

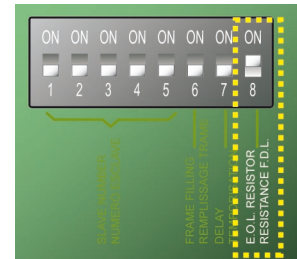

Figure 13: End Of Line Resistor is set to ON

## 5.4 Relay modules

### 5.4.1 Function

This digital module, available in two versions, allows for the management of: 1 to 4 relay outputs;

- or 1 to 8 relays.

In addition, it has 2 logic inputs.

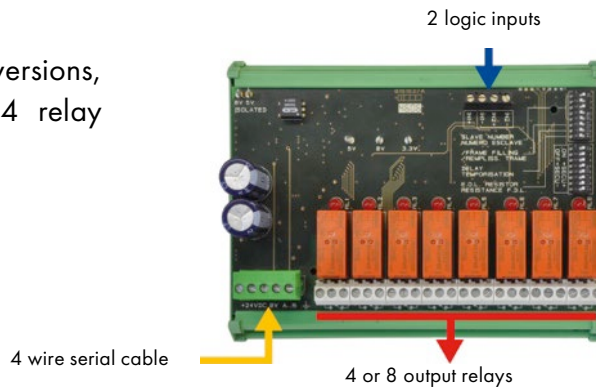

Figure 14: 8 relay module

### 5.4.2 Introduction

Ref..	Description
A.	Logic Inputs
B.	DIP switches for module configuration
C.	DIP switches for relays configuration
D.	Power supply and RS485 network
E.	Programmable relays (4 or 8)
F.	Relay status visual indicators
G.	Relay terminals

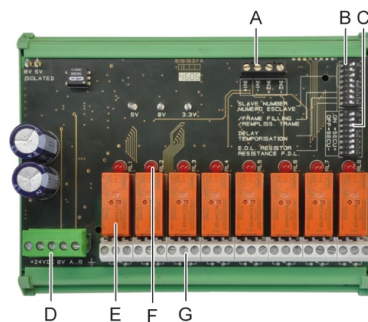

Figure 15: 8 relay module

**A – Logic input terminals** Each of these two terminals may be connected to a voltage-free contact as per Figure 29.

**B – Module configuration DIP switches** These DIP switches are set according to the following table.

Term	Symbol
<i>Slave number</i> Numéro esclave	See details in the paragraph <i>Module Address</i> on page 22.
<i>Frame filling</i> Remplissage de trame	Factory settings. Do not modify.
<i>Delay</i> Temporisation	Factory settings. Do not modify.
<i>E.O.L Resistor</i> Résistance F.D.L.	See details in paragraph <i>End of line Resistor</i> , on page 24.

Table 6: *Relay module* configuration DIP switches

**C – Relay configuration DIP switches** The DIP switches allow to choose between normally energized relay (the coil is energized when not in alarm) or normally de-energized relay (the coil is energized when in alarm). Set the switch to ON for energized relay or OFF for de-energized relay. Each switch drives the relay having the same number (switch #1 acts on relay #1). The contacts are represented with the module not powered.

Re the 4 relay module, only switches #1 to #4 are active.

### E – Programmable relays

The 2 line *MX32v2* model can manage up to 16 external relays (limited to 4 relay output modules). The relays are individually programmable. The operation of each relay depends on its configuration.

Each detector event [AL1 - AL2 - AL3 – OVS – UDS – Failure] can control one or several relays. Several events can be assigned to the same relay.

*Setting of relay parameters* Relays are to be configured via the *COM 32* configuration software.

- **Normal:** Relay operation as per the normal management of an alarm (the relay follows the alarm event))
- **Buzzer function (resettable relay):** Mainly used for sounder activation. Buzzer operates as a normal relay; however it can be reset even if the alarm is still present (in order to turn off the audible alarm). The different time delays are:

- Reset Inhibit: minimum time of activation, adjustable from 0 to 900 seconds
- Automatic reset: If activated, the time is adjustable between 15 and 900 seconds, beyond which the relay is automatically deactivated

- Reactivation time: If checked, time is adjustable between 15 and 900 seconds, beyond which the relay is reactivated.

#### *Controls of the alarm relay*

- Logic equations of up to 4 levels of parentheses by the logic operators OR, AND, NOR, and NAND. The result of the equation drives the relay
- Vote (x over y). There must be at least “x” events over the total of “y” to activate the relay. Optionally, the user may define whether a failure is considered as an alarm.

#### **F – Relay status indicator**

The status of each relay is visualized by a red LED:

- LED is OFF: the coil is not powered
- LED is ON: the coil is powered

#### **G – Relay output connectors**

Overvoltage Category II. Contact rating is 2A @ 250Vac or 30Vdc.

### 5.4.3 Connection

Refer to chapter 6, on page 33

### 5.4.4 Configuration

Configured via the *COM 32* application

## 5.5 16-Logic Input Module Function

This digital module allows the monitoring of 1 to 16 dry logic inputs. The controller can manage up to 16 logic inputs limited to 2 modules.

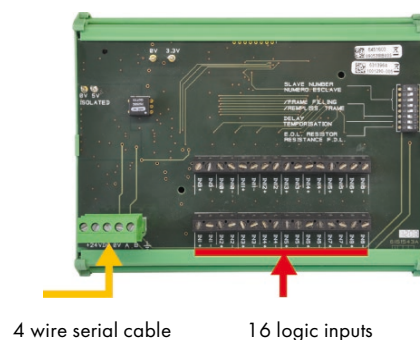

**Figure 16: 16 Logic Input Module**



## 5.5.2 Introduction

Ref.	Description
A.	DIP switches for module configuration
B.	Power supply and RS485 network
C.	Logic inputs 1 to 16

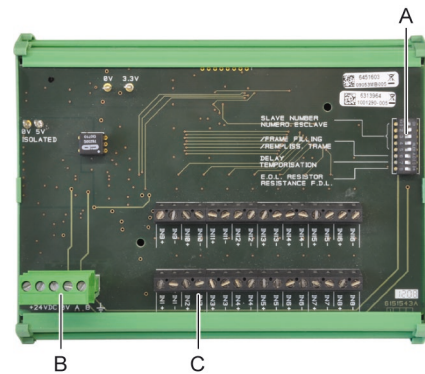

Figure 17: 16 Logic Input Module

**A – DIP switches** These DIP switches are set according to the following table:

Term	Symbol
<i>Slave number</i> Numéro esclave	See details in the paragraph <i>Module Address</i> on page 22
<i>Frame filling</i> Remplissage de trame	Factory settings. Do not modify
<i>Delay</i> Temporisation	Factory settings. Do not modify
<i>E.O.L Resistor</i> Résistance F.D.L.	See details in paragraph <i>End of line Resistor</i> , on page 24

Table 7: Configuration DIP switches of the *Logic Input Module*

**C – Logic input connectors** Each of these 16 inputs can be connected to a voltage-free contact as per Figure 30. Input status is transmitted by the digital line to the *MX32v2*. There is no alarm when the contact is closed.

## 5.5.3 Connection

Refer to Chapter 6, on page 33

## 5.5.4 Configuration

Configured via the *COM 32* application

## 5.6 8-Analog Input Module

### 5.6.1 Function

This digital module enables the monitoring of 8 analog inputs (4-20 mA or Wheatstone bridge)

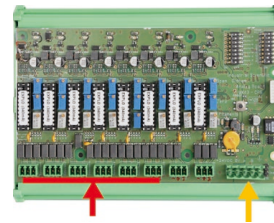

8 analog inputs      4 wire serial cable

**Figure 18: 8 Analog Input Module**

### 5.6.2 Introduction

Ref..	Description
A.	Configuration jumper (4-20mA or Wheatstone bridge)
B.	Span settings
C.	Zero settings
D.	Channel Offset
E.	Bridge sensor Offset
F.	Channel ON/OFF
G.	0V terminal for 4-20mA calibration
H.	DIP swithes for the configuration of the module (address, delay)
J.	Inputs no.1 to 8 (4-20mA or Wheatstone bridge as per A)
K.	Catalytic bead current adjustment (factory setting).
L.	4-20mA division strap in case of several analog detectors operating on the same line (car park application)
M.	Power supply and RS485 digital network connector
N.	End of line resistor jumper

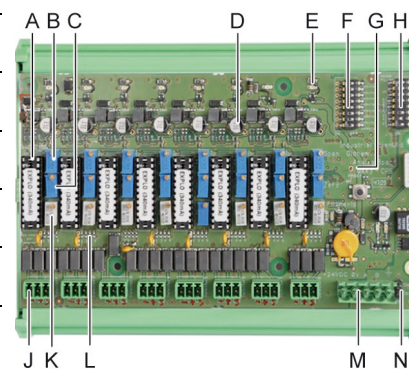

**Figure 19: 8 Analog Input Module**

**E – Module configuration DIP switches** DIP switches are set according to the following table:

Term	Symbol
<i>Slave number</i> Numéro esclave	See details in the paragraph <i>Module Address</i> on page 22
Frame filling Remplissage de trame	Factory settings. Do not modify
<i>Delay</i> Temporisation	Factory settings. Do not modify
<i>E.O.L. Resistor</i> Résistance F.D.L.	See details in paragraph <i>End of line Resistor</i> , on page 24

Table 8: Configuration DIP switches of the *Analog Input Module*

### 5.6.3 Connection

Refer to Chapter 6, on page 33

### 5.6.4 Configuration

Configured via the *COM 32* application

Note related to manual calibration of the detectors connected to an 8-analog input module.

#### 1. Zero calibration

Inject zero grade air to obtain 4 mA. Place the multimeter between points E and D (Figure 19). If the value measured is different from 0 V, adjust C.

#### 2. Sensitivity calibration

After applying gas, place the multimeter between points E and D (Figure 19). If the value measured is different from 1.6 V, adjust B.

Should the adjustment value be different, calculate:  $V = I \text{ (mA)} \times 0.10 \text{ (V/mA)}$

Example: If the current is 12 mA, "V" must be equal to 0.8 V

## 5.7 4-Analog Output Module

### Function

This digital module delivers 1 to 4 discrete opto-isolated analog outputs deactivated. Several detectors can be assigned to one output allowing the management of the lowest, highest and averaged value. When non configured, the analog output is set to 0mA. The module also features two logic inputs.

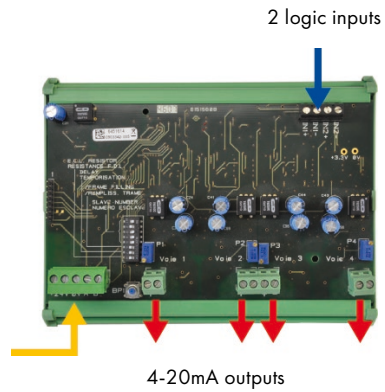

Figure 20: 4 Analog Output Module

### 5.7.1 Introduction

Ref.	Description	
A.	Logic Inputs	
B.	Power supply and RS485 network	
C.	DIP switches for module configuration	
D.	Push-button. Pressing this button forces all outputs to 20mA	
E.	(E1 to E4) discrete opto-isolated analog outputs	4-20mA
F.	(F1 to F4) current output settings. Press D and set to 20mA	

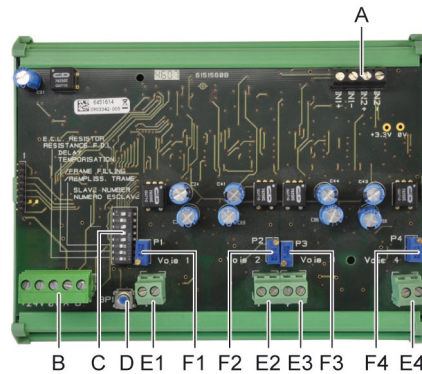

Figure 21: 4 Analog Output Module

**A – Logic input connectors** Each of these two terminals may be connected to a voltage-free contact in accordance with Figure 31

**C – Module configuration DIP switches** These switches are set according to the following table:

Term	Symbol
<i>Slave number</i> Numéro esclave	See details in the paragraph <i>Module Address</i> on page 22
<i>Frame filling</i> Remplissage de trame	Factory settings. Do not modify
<i>Delay</i> Temporisation	Factory settings. Do not modify
<i>E.O.L. Resistor</i> Résistance F.D.L.	See details in paragraph <i>End of line Resistor</i> , on page 24

Table 9: Analog Output Module Configuration DIP switches

## 5.7.2 Connection

Refer to Chapter 6, on page 33

## 5.7.3 Configuration

Configured via the *COM 32* application

# **MX32v2**

ANALOG AND DIGITAL CONTROLLER  
USER MANUAL

## 6 Wiring and Electrical Connections

This chapter details the electrical connections of all components of the system (MX32v2, modules, additional equipment).

### 6.1 Controller Connection

The electrical connections must be carried out by qualified personnel in compliance with the different directives in force in the country of installation.



The *MX32v2* does not have a start/stop switch.

Certain voltage levels are capable of causing serious injuries or even death. It is advised to install the material and cabling before applying live voltage.

Since an incorrect or poor installation may cause measurement errors or system failures, it is necessary to strictly follow all the instructions in this manual in order to guarantee the proper operation of the system.

Certified strain relief bushing required. Utilized cords shall comply with all certified bushing specifications.

Suitable external cords shall be used in the end application and shall be according to local rules/standards for *MX32v2* product.

Cables with an operating temperature of 70°C minimum (158 °F) must be used because the temperature inside the controller can reach 70°C (158 °F).

---

#### 6.1.1 Access to terminal blocks

After unlocking the two toggle latches, swing the front cover towards the left in order to access the wiring terminal.

#### 6.1.2 100-240 Vac Power Supply

The *MX32v2* can be powered from a 100-240Vac source at 50/60 Hz, 1.5A max. Check the nature of the current and the voltage value prior to any connection. The electrical connections must be carried when power is down.

A bipolar differential circuit breaker, 4A, type C, must be included in the installation as means for disconnection. It must be suitably located and easily reached and must be marked as the disconnecting device for the *MX32v2*.

The main power shall be connected to the terminal block as indicated in Figure 22. The ground conductor shall be connected to the ground terminal . Connect earth before connecting L/N conductors. Disconnect earth after disconnecting L/N conductors.

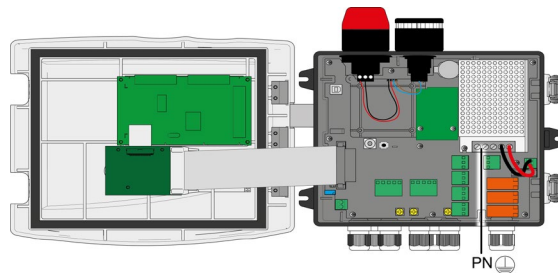

Figure 22: Connection of the main power supply

### 6.1.3 External 24Vdc Power Supply



*MX32v2* should be powered by either a certified (by CSA/UL depending on the country of installation) Class 2 power supply or a certified Limited Energy power supply in accordance with CSA 61010-1-12 or UL 61010-1 or IEC 61010-1 standards (depending on the country of installation).

In this case, connect the 24Vdc power supply to the corresponding terminal (Figure 23, A). This terminal is protected by a 4A fuse located below terminal tag A.

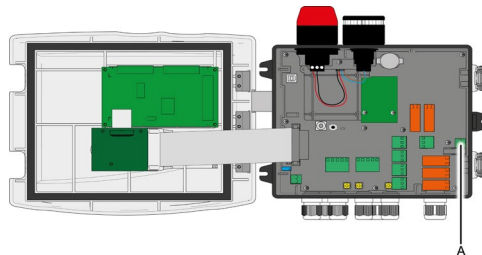

Figure 23: Connection of 24Vdc external power supply (A)

**6.1.4 Grounding** The *MX32v2* meets EMC and Low Voltage Directives requirements. In order to fully comply with the class of protection, it is absolutely necessary to connect the ground terminal to the Earth of the site (Figure 24, A). Moreover, the cable braids of the digital and analog lines shall also be connected to this ground terminal.

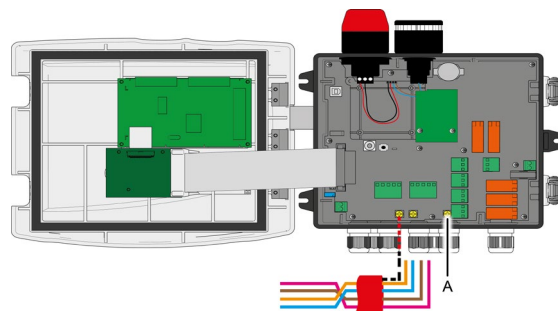

Figure 24: Ground and braid connection



**6.1.5 Digital lines** The cabling of the digital lines connecting the controller to the different modules deployed along the lines are the subject of the paragraphs *OLCT 10N Modules, 4- or 8-relay modules, 16-logic input modules, 8-analog input modules and 4-analog output modules* of this same chapter. It should be remembered that this cable comes in 2 twisted pairs of 4 x 0.22 m<sup>2</sup> minimum, type MPI-22A, nominal impedance of 100 Ohms.

**6.1.6 Analog or Wheatstone lines**

For an analog 4-20mA detector connected directly to the *MX32v2* line, please wire the detector as shown below.

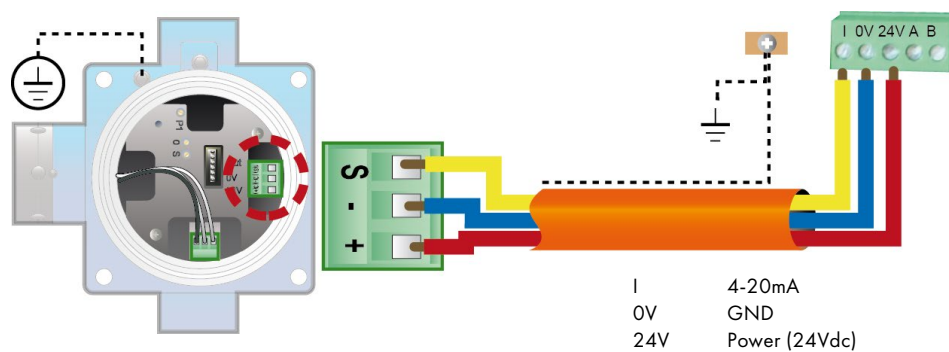

Figure 25: 4-20mA detector connected to an analog line

In the case of a mV flammable gas detector connected directly to the *MX32v2* line, please wire the detector as shown below.

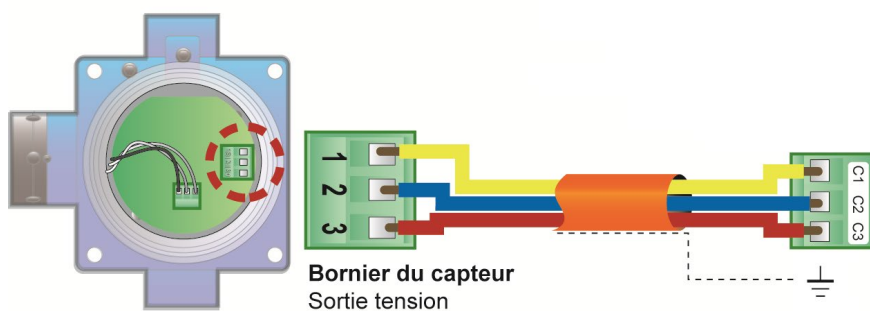

Figure 26: connection of a Wheatstone type gas detector to a Wheatstone type *MX32v2*

**6.1.7 Internal alarm relays** The *MX32v2* has 5 internal relays:

Output	Function
R1	Programmable Alarm Relay
R2	Programmable Alarm Relay
R3	Programmable Alarm Relay
R4	Programmable Alarm Relay
Failure :(Fault)	Non-programmable common relay, energized, activated upon the presence of a failure in the <i>MX32v2</i> (detector and/or module, system failure, etc.). The acknowledgement of this relay is automatic.

The dry relay contacts (nominal resistive load of 5A at 250Vac or 30Vdc) are identified as R1, R2, R3, R4 (Figure 27, tag A) and Fault (Figure 27, tag B).

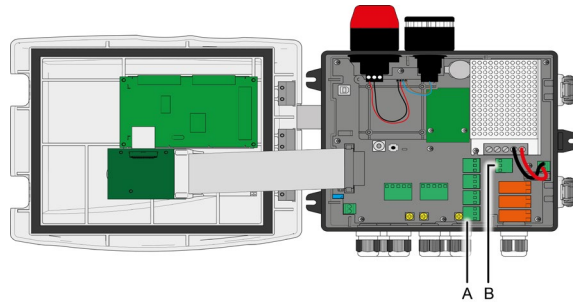

Figure 27: Internal alarm relays (A) and fault relay (B) terminals



The relay contacts are represented when no power applies to the *MX32v2*. The relays are programmed via the *COM 32* application and can be set as energized or de-energized.

**6.1.8 Remote Acknowledgement Connector** If necessary, connect the ACQUIT (dry contact relay, NC) terminal to a remote acknowledgement system.

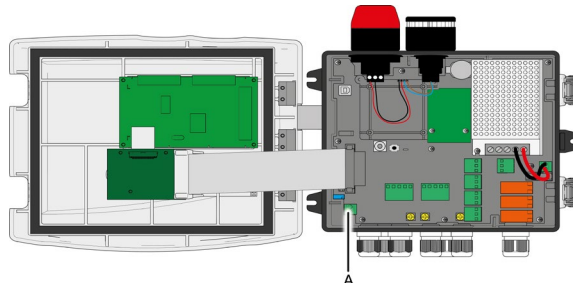

Figure 28: Remote acknowledgement connection (A).

## 6.2 4- or 8-Relay Modules

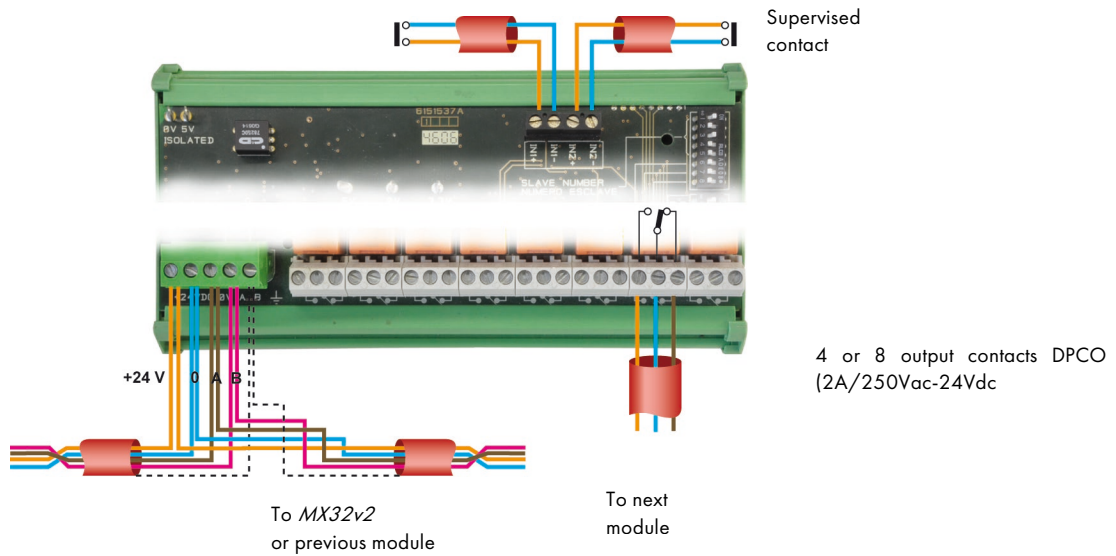

Figure 29: 4- or 8-relay module connections



If this module is the last on the line, do not forget to set the switch marked *EOL resistor/resistance FDL* to ON.

## 6.3 16-Logic Input Module

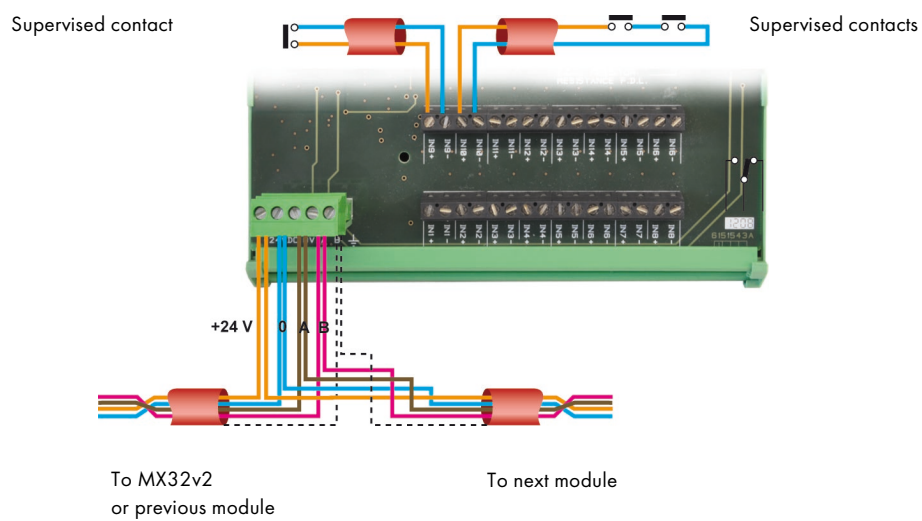

Figure 30: 16-logic input module connections.



If this module is the last on the line, do not forget to set the switch marked *EOL resistor/resistance FDL* to ON.

## 6.4 8-Analog Input Module

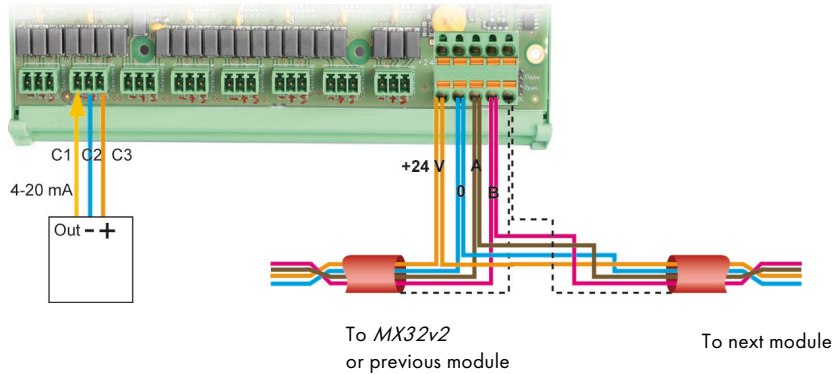

Figure 31: Connection of the 8 analog input modules (with 4-20mA detector)

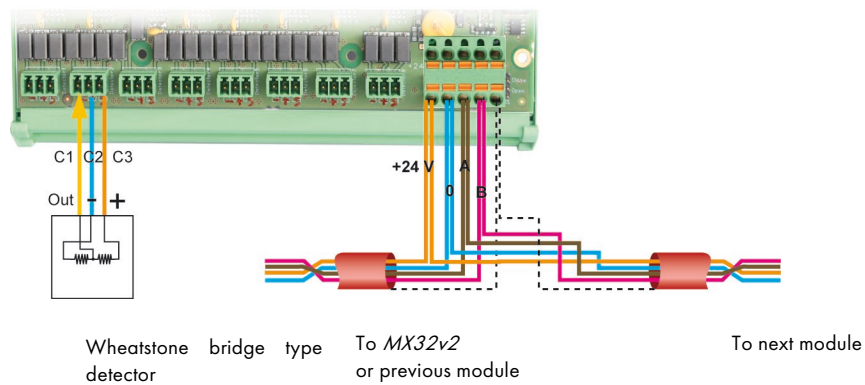

Figure 32: connection of the 8 analog input module (with Wheatstone Bridge detector)



If this module is the last of the line, do not forget to set the jumper marked *EOL Resistor* to *Closed* position.

## 6.5 4 Analog Output Module

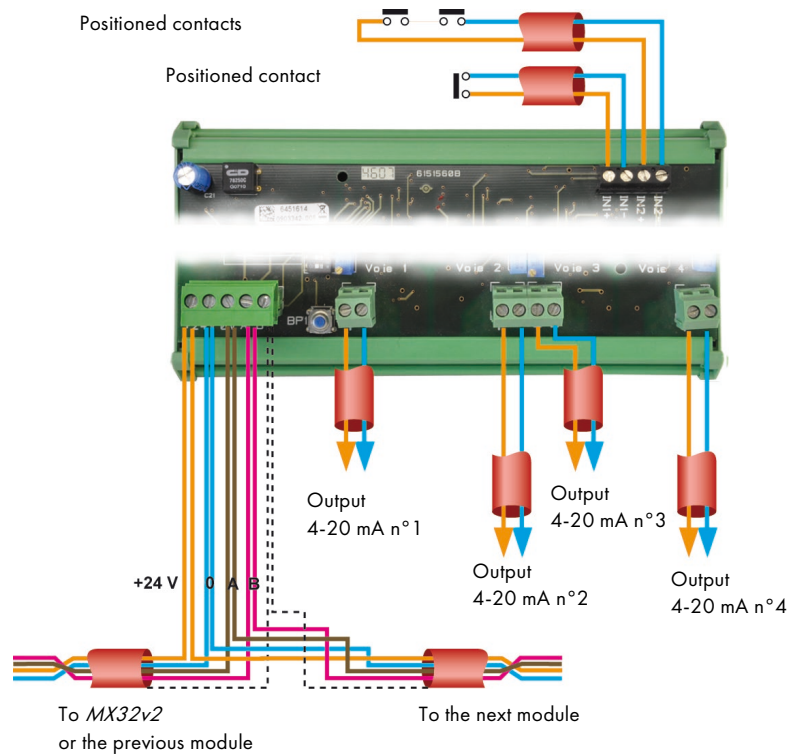

Figure 33: 4-analog output module connections.



If this module is the last of the line, do not forget to set the switch marked *EOL Resistor/FDL resistance* to the ON position.

# **MX32v2**

ANALOG AND DIGITAL CONTROLLER  
USER MANUAL

# 7 Menus

## 7.1 General Menu Tree

The following figure shows the general tree of the group of menus.

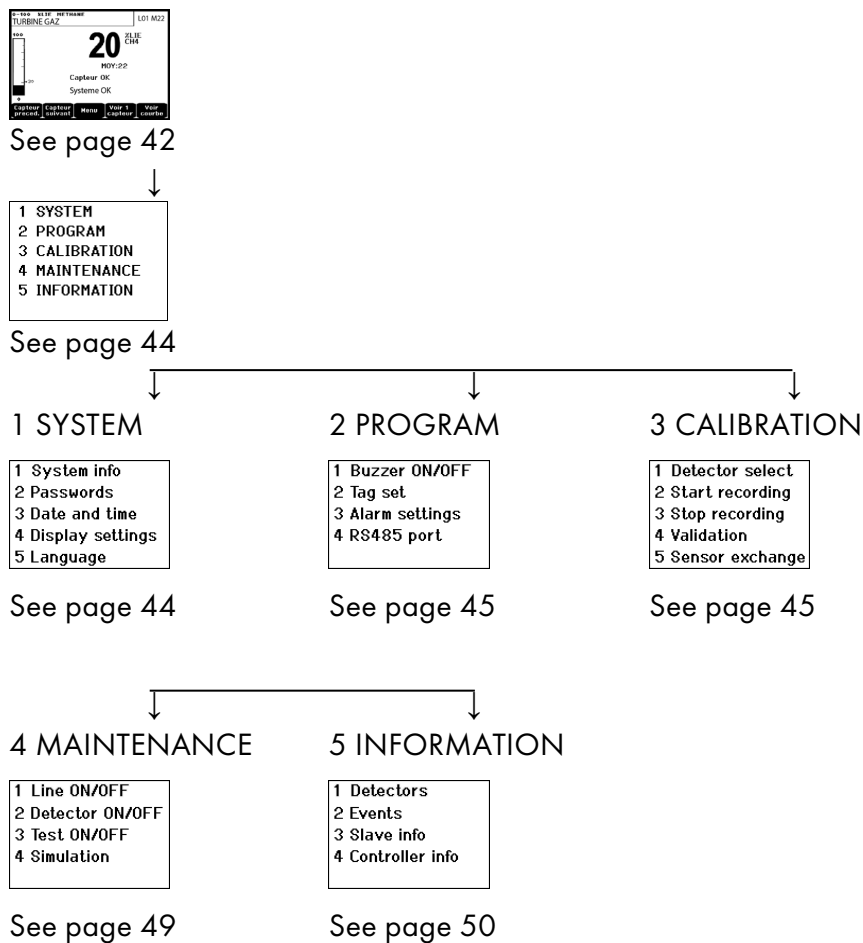

Figure 34: General menu tree of the *MX32v2*

## 7.2 Navigation Key Functions

Key	Function
↑↓	Vertical displacement in the selected menu block.
→←	Horizontal displacement between two menu blocks.
Enter	Validation of the selected line.
Escape	Return to previous screen.

Table 10: Function of the navigation keys

## 7.3 Display in normal mode Measurement Display

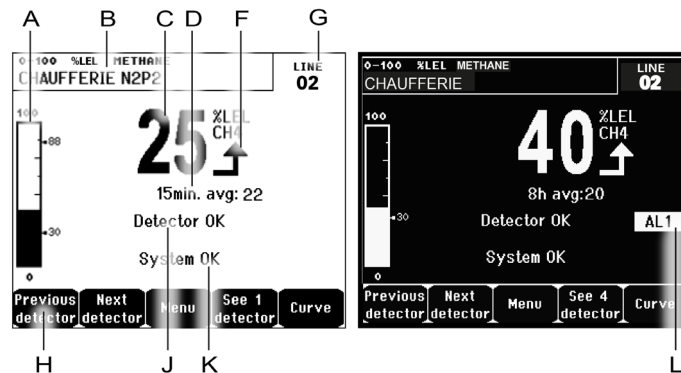

Figure 35: Example of the measurement display in normal mode and in grayscale mode

Ref.	Significance
A.	Barograph with an indication of alarm limits.
B.	Measurement range, gas detected, and detector language.
C.	Value of the current measurement with the unit and gas detected.
D.	Value of the average measurement if this function has been activated via the <i>COM 32</i> application and depending on the display settings (see <i>Display Settings</i> , on page 44).
F.	Indicator of measurement trend ↑ Ascending tendency ↓ Descending tendency
G.	Address of digital detector on a digital line or channel number for a analog detector



Ref.	Significance
H.	<p>Function keys. <b>Previous detector</b>: Display of measurements of previous detector; scanning of all the detectors on all the lines.</p> <ul style="list-style-type: none"> <li>• <b>Next detector</b>: Display of measurements of next detector; scanning of all the detectors on all the lines.</li> <li>• <b>Menu</b>: Display of main menu See paragraph "Main menu" on page 44.</li> <li>• <b>See 4 Detectors</b>: Display of a group of 4 detectors (detector tag, barograph with indication of alarms, value of current measurement with unit and gas detected). Use the <b>Page down</b> or <b>Page up</b> keys to display all of the next 4 detectors; passage to the next zone is automatic.</li> <li>• <b>See 8 Detectors</b>: Display of a group of 8 detectors (detector tag, value of current measurement with unit and gas detected). Other buttons similar to the selection. <i>See 4 detectors.</i></li> <li>• <b>See 1 detector</b>: Display in normal mode (Figure 35).</li> <li>• <b>Curve</b>: Display of the measurement curves of the last 10 days (Figure 36). The → and ← keys allow cursor displacement through the time scale. The vertical dotted line displays the concentration and time stamp of the point being considered. Escape: return to display of values.</li> </ul>
J.	Information on the detector status.
K.	Information on the MX32v2 status.
L.	Zone of indication of activated alarms with blinking threshold display. The screen changes to inverse video (Figure 35).

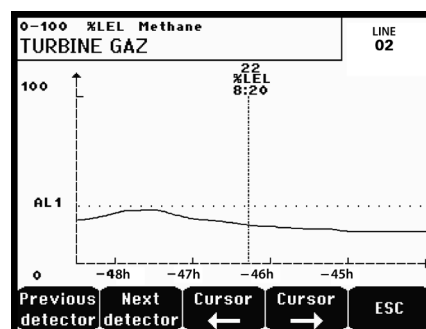

Figure 36: Example of a curve display screen

## 7.4 Main Menu

This displays all the management menus of *MX32v2*.

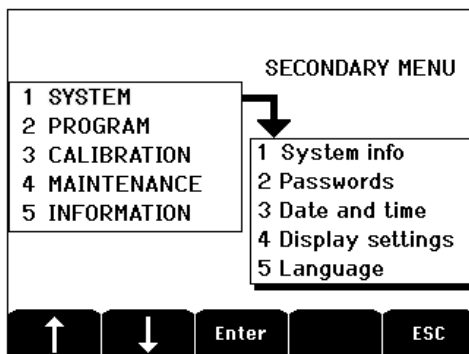

Figure 37: Main menu

## 7.5 System

■ 1. System Info

Displays the version of the program, the *bootloader* (internal micro-software for loading the program), and the configuration, as well as software application verifications.

■ 2. Passwords

The controller is protected by two access codes, both set at 1000 by default upon leaving the factory. You can change the passwords in this menu via *COM 32*. The passwords are required each time you enter one of the menus that they protect. **First-level password:** Authorizes access to the Calibration menu.

**Second-level password:** Authorizes access to the Programming, Calibration, and Maintenance menus. This password is also required before menu data are deleted.

■ 3. Date and time

Time stamp settings (year, month, day, hour, minute, second).

■ 4. Display settings

*Scrolling display*

- OFF: the display is frozen on a selected detector.
- ON: scrolls through detectors every two seconds.

*By zone*

- ON: displays all detectors assigned to the same zone (same bar of leds).
- OFF: displays all connected detectors regardless the zone they are assigned to.

*Screen saver*

- OFF: no screen saver.
- ON: turns into the screen saver mode (displays TELEDYNE OLDHAM SIMTRONICS logo) if no key is pressed for a certain period of time.
- Averaged value
- OFF: averaged gas measurement value is not displayed.
- ON: displays the averaged gas measurement values over the last fifteen minutes or eight hours depending on the settings done with COM 32. Typically used when toxic gas detectors.

- 5. Language      Selection of the display menu language.

## 7.6 Program

- 1. Buzzer On/Off      Activates or deactivates the internal buzzer of the *MX32v2*.
- 2. Tag set      Allows for the modification of detector tags previously programmed via *COM 32*.
- 3. Alarm settings      Allows for the modification of detector alarms previously programmed via *COM 32*.
- 4. Port RS485      Configuration of Port RS485 (speed, parity, stop bits, slave number). This configuration is only useful if the *MX32v2* is equipped with the RS485 communication card.

## 7.7 Calibration



If the measurement cell has changed, it is important to declare this through a menu no. *5 Cell change*.

---

### 1. Detector select.

This menu enables the selection of detectors to be calibrated (calibration from *MX32v2* or on the detector).

- A. Display of information described by the *COM 32* application: i.e., measurement range, gas detected, current detector ID and its type.
- B. Display for the current detector:
  - **Last passed calibration:** Date and time of the last calibration carried out and completed.
  - **Last sensor replacement:** Date and time of last cell change.
  - **Wear rate:** Relation between the value of the standard gas and the value read (sensitivity measurement). A wear rate in excess of 100% entails a sensor replacement.
- C. Display of the address (digital detector) or line number (analog detector) to which the detector is connected.
- D. Selecting the detectors to be calibrated: Select one or several detectors using the **previous detector** or **next detector** keys.
  - On pressing the **Select** key, press **Cal gas** to enter its value by means of the  $\uparrow\downarrow$  keys. Validate by pressing **Enter**.
  - *Note: Only analog detectors that are not equipped with a local display can be calibrated from the MX32v2 controller. For the other detectors, the menu "Sel. Detector" only makes it possible to put them in calibration mode so that they do not activate alarms during their manual calibration.*
  - Press **Escape** to launch the procedure of recording the measurements on the detectors to be calibrated. Proceed to paragraph "2 Recording".
- E. Display the calibration gas.

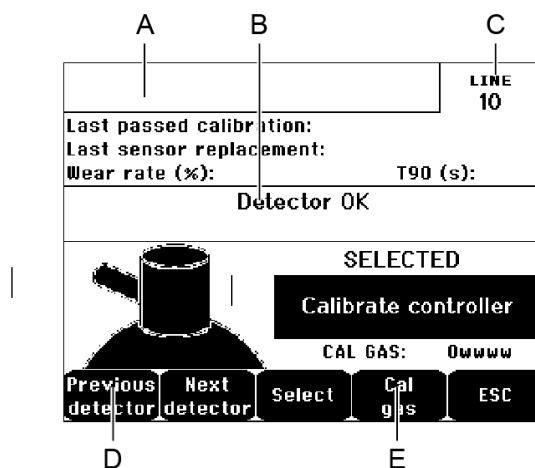

Figure 38: Example of the "Select detectors" screen

## 7.7.1 2. Start Recording

- **Yes:** Launches the recording of calibration measurements for the selected detectors. From this moment onwards, all the calibration measurements are recorded for these detectors. "Start recording" is then displayed. The calibration of the detectors with the help of the standard gas can begin.

*For a detector in which the cell has been changed, it is important to adjust the detector locally to obtain a 4-20mA output corresponding to the detector range.*

*For detectors connected to the analog input module, perform the adjustments directly on the module (see page28 ).*

---

Attention: During calibration, the standard gas must be injected for at least thirty seconds.

---

- **No:** Exits the recording procedure

## 7.7.2 3. Stop recording

- **Yes:** Detector calibration having finished, this validates the end of calibration measurement recording for the detectors previously selected. From this moment onward, no calibration measurement is recorded. "Stop recording" is then displayed.
- **No:** Exits the end of the recording procedure.

## 7.7.3 4. Validation

This allows the adjustment and validation of zero and detector sensitivity once calibration is completed.

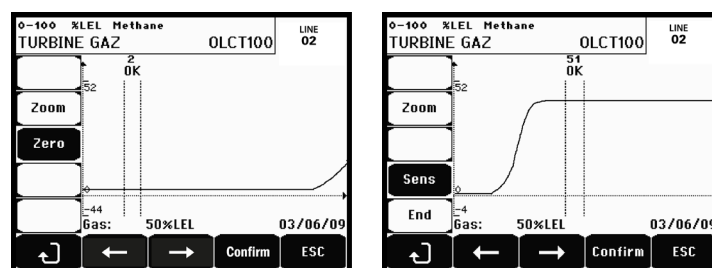

Figure 39: Adjustment of zero (left) and sensitivity (right)

## 7.7.4 Operating mode

### *Detector selection*

1. Select the detector to be calibrated with the help of the **Previous detector** and **Next detector** keys and press **Validate**.

### *Zero calibration*

1. The **Zoom** command is active.
2. Select the area of interest of the curve with the ← and → keys. Press **Zoom +** up to the activation of the Zero command. Adjust the position of the cursor so as to make the "OK" appear, in turn indicating that the range selected is sufficiently stable.
3. Press ↵ to select the term **Zero**.
4. Confirm the zero calibration by pressing **Validate zero**.
5. The term **Sens** (for sensitivity) is active from now on.

If sensitivity is not to be calibrated, press ↵ and **END**; until you see the message "Do you only want to calibrate zero for the detector?", then press **Validate calibration**. Only the zero calibration of the detector will have been carried out.

If sensitivity is to be calibrated, proceed directly to the following paragraph.

### *Sensitivity calibration*

1. The **Sens** command is active.
2. Select the area of interest of the curve with the ← and → keys. Press **Zoom +** up to the activation of the command Sens. If applicable, adjust the position of the cursor so as to make the "OK" appear, in turn indicating that the range that has been selected is sufficiently stable.
3. Confirm the sensitivity calibration by pressing **Validate Sens**.

### *Record the calibration*

1. The message "Do you want to validate zero and detector sensitivity?" is displayed. Press **Validate calibration** to confirm the adjustment of zero and sensitivity or **Esc** to exit the procedure.
2. The detector is calibrated.

## 7.7.5 5. Sensor exchange

This function reboots the parameters (rate of wear, calibration date, internal parameters corresponding to the 4-20mA range, etc.) from the selected detector(s) following or in view of a change of cell.

### *Detector Selection*

1. Select the detector(s) to be rebooted with the help of the **Previous detector**, and **Next detector** keys and press **Select**.

### *Initialization of the Detector*

1. Press Escape to reset the selected cells
2. Proceed with the cell replacement and then calibrate locally the corresponding detectors
3. Proceed with the calibration from the *MX32v2* via the menus "1 Sel detectors", "2 recording", "End recording" and "4 validation" in order to save data calibration (wear rate, date of calibration, response time, etc.).

## 7.8 4. Maintenance

### 7.8.1 Access

Successively press the keys **Menus** and **Maintenance**.

### 7.8.2 1. Line On/Off

Sets the line to stop (the line is not powered and the detectors are at stop; no event can be generated from then on).

### 7.8.3 2. Detector On/Off

Sets the detector to stop (no event can be generated from then on) if it was not issuing an alarm or failure.

### 7.8.4 3. Test On/Of

This allows for the verification of the proper operation of a detector. In this mode, recordings and alarm relays are suppressed.

## 7.8.5 4. Simulation

Upon its selection, the message “The controller no longer ensures detection” is displayed.

- The controller no longer keeps account of inputs (detectors, logic inputs).
- The simulation measurements/status are initialized to the current measurement/status values. The relays, the internal buzzer, and the analog outputs remain in their current status.
- The screens, management of relays, outputs, etc. are those of Normal operation.
- The internal relay and the common default LED are activated.
- To change the value of a detector, use the ↓↑ keys to increase or decrease the measurement value simulated from –15% to 115%. For a logic input, use the ←→ keys to select the input, ↓↑ to select Alarm or Alarm Off.
- The banner of alarms does not appear.
- The events log indicates Begin Simulation and End Simulation.
- Exit the simulation mode by pressing the End simul key. Automatic release then occurs and resets the average values to zero. The current measurements are displayed once more.

## 7.9 5. Information

### 1. Detectors

This displays the main information on the detector (type, range, detected gas).

### 7.9.1 2. Events

Alarm events				
TURBINE GAZ	AL1	ON	08 01 10	11:40:01
TURBINE GAZ	AL1	OFF	08 01 10	15:16:40
Previous page	Next page	Last page	Delete	ESC

Figure 40: Example of gas alarm records

#### 1. Alarm events

This displays, for each of the detectors concerned: detector ID, alarm type (Al1, Al2, Al3, Al1mean, Al2mean, Al3mean, OVS), status (activated = ON or deactivated = OFF) as well as the date and time of occurrence or of the release.



The letter "S" appears on the line if the events were obtained when the *MX32v2* was in simulation mode. **Delete** deletes all the data. Up to 512 events can be memorized. Beyond that, the most recent event deletes the oldest. **Previous page**, **Next page**, and **Last page** access the corresponding pages of the file.

Message	Significance
AL1	Detector in level 1 alarm
AL2	Detector in level 2 alarm
AL3	Detector in level 3 alarm
OVS	Detector in OVS alarm
AL1 M	Detector in alarm set to level 1 mean value
AL2 M	Detector in alarm set to level 2 mean value
AL3 M	Detector in alarm set to level 3 mean value

Table 11: Gas alarm file messages.

## 2. Fault records

This displays, for each detector concerned: event type (UDS = Under-scale), RANGE = measurement out of range, DEF =Failure, DOUBT = clear doubt), status (activated = ON or deactivated = OFF) as well as the date and time of appearance or release. This file cannot be deleted.

Message	Significance
UDS	The measurement is lower or equal to the value of the UDS programmed.
DEF	Detector failure (out of range, line cut, defective cell, etc.).
RANGE	Measurement out of range.
>> LEL	Concentration higher than 100% of LEL.

Table 12: Failure file messages

## 3. Inputs and relays records

This displays, for each relay and logic input concerned: activated relay/input ID, type (REL = relay, EL = Logic input), its status (activated = ON, Deactivated = OFF) as well as the date and time of occurrence or release. **Delete** allows for the deletion of this entire file. Up to 512 events can be memorized. Beyond that, the most recent event deletes the oldest. **Previous page**, **Next page**, and **Last page** access the corresponding pages of the file.

Message	Significance
RELAY	Status change of the designated relay.
INPUT	Status change of the designated input.

Table 13: Relay and logic input file messages.

#### 4. Working conditions records

This displays the actions carried out on the *MX32v2* (simulation mode, calibration mode, programming mode, release request, operation on internal battery), as well as the date and time of beginning and end of the event. **Delete** allows for the deletion of this entire monitoring file. Up to 512 events can be memorized. Beyond that, the most recent event deletes the oldest. **Previous page**, **Next page**, and **Last page** allow access to the corresponding pages of the file; each page can display a maximum of 8 lines.

Message	Significance
Line 1 On/Off	Start or stop line 1
Line 2 On/Off	Start or stop line 2
Detectors On/Off	Start or stop the detector
External ack.	Press the external acknowledgement button
<i>MX32v2</i> ack	Acknowledgement by the acknowledgement button on the front plate of <i>MX32v2</i>
Simulation	Switch to simulation mode
Calibration	At least one of the detectors is selected in calibration mode.
Test detectors	Switch to test mode
Program	Programming done on <i>MX32v2</i>
Time settings	Time settings on <i>MX32v2</i>

Table 14: Operation monitoring file messages.

#### 5. Hardware troubles records

This displays, for each material incident detected: incident ID, status (activated = ON or deactivated = OFF) as well as the date and time of occurrence or release of the event. **Previous page**, **Next page**, and **Last page** allow access to the corresponding pages of the file: each page can display a maximum of 8 lines.

Message	Significance
DEAD	Digital module no longer responding (line cut, module failure, wrong address, module absent).
MODUL	Configuration or module address error.
TEMP+	Internal temperature of the <i>MX32v2</i> higher than maximum tolerated value.
TEMP-	Internal temperature of the <i>MX32v2</i> lower than maximum tolerated value.
LINE 1	Incident on line 1 (short-circuit).
LINE 2	Incident on line 2 (short-circuit).
CAL O	Calibration defect (zero shifted).
CAL S	Calibration defect (used cell).
CAL F	Calibration defect (cell oversensitive).
CAL D	Calibration defect (measurement unstable).

Table 15: Material incidents file messages

## 6. System troubles records

This displays the events relative to *MX32v2* operation (power failure/fluctuation, On/Off, etc.). **Previous page**, **Next page**, and **Last page** allow access to the corresponding pages of the file; each page can display a maximum of 8 lines.

Message	Significance
ON	<i>MX32v2</i> on live voltage
OFF	<i>MX32v2</i> off voltage
Self-testing failure	Failure of internal tests
Other messages	Contact Post-Sales Service

Table 16: System incidents file messages

## 7.9.2 3. Slave info

These data enable maintenance technicians to visualize the communication framework between *MX32v2* and the digital modules.

## 7.9.3 4. Controller info

These data allow technicians to visualize different counters such as number of resets on low voltage input, error system, configuration, etc.

# **MX32v2**





ANALOG AND DIGITAL CONTROLLER  
USER MANUAL

## 8 Main Part Numbers

### MX32-A-B-C-D-E-F-0-1

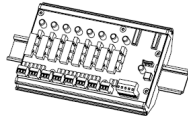
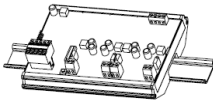
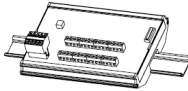
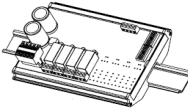
<b>Version</b>	<b>Power supply</b>	<b>Language</b>	<b>Strobe and Audible alarm combination</b>	<b>RS 485 serial output</b>	<b>Com 32 software</b>
1 - 1 channel 2 - 2 channels 3 - Wheatstone bridge	1 - 24Vdc 2 - 100/240Vac	1 - French 2 - English	0 - Without 1 - red 2 - Blue	0 - Without 1 - With	0 - without 1 - with

f.i: MX32-1-2-2-1-1-0-1 for MX32 1 channel, 100/240Vac, English, Blue strobe and horn, RS 485 output and COM 32 software

Description	Reference	Image
8 Analog Input Module	6 314 061	
4 Analog Output Module	6 313 980	
16 Logic Input Module	6 313 964	
4 Relay Output Module	6 313 962	
8 Relay Output Module	6 313 963	
Red Flash and buzzer kit	6 314 208	
Blue flash and buzzer kit	6 314 209	

Description	Reference	Image
RS485 communication board	6 451 680	
100-240Vac/24Vdc Power Supply	6 314 210	
Fuse F7 (4A time-delay, 8.4A for 120 seconds - 250Vac)	6 154 738	
CR2032 lithium battery	6 111 321	
340 mA programming strip (8 maximum per analog input module), see Figure 19	6 353 442	
4-20 mA programming strip (8 maximum per analog input module), see Figure 19	6 353 443	

## 9 Cleaning and maintenance

### 9.1 Cleaning

Do not use alcohol- or ammonia-based liquids to clean the controller. If necessary, clean the exterior of the enclosure with a damp cloth.

### 9.2 Fuse replacement



Fuse replacement should only be performed by qualified personnel and power must be first switched off.

---

Fuses shall comply with IEC 60127 standard (time-delay fuse, low breaking capacity, 250Vac). Please see 0.

### 9.3 Replacement of the lithium battery

Lithium battery replacement should only be performed by qualified personnel and with an identical battery (see Chapter 8 for the list of spare parts). The controller must be first switched off. Power on the controller once the battery has been replaced.



TELEDYNE OLDHAM SIMTRONICS does not allow any other repairs than those listed here above.

---



Burn hazard. As the temperature inside the controller can reach 70°C (158 °F), it should be allowed to cool after aperture.

---

# **MX32v2**

ANALOG AND DIGITAL CONTROLLER  
USER MANUAL



## 10 Certificate of Compliance

The document hereafter (2 page) reproduces the EU declaration of conformity.



**DECLARATION UE DE  
CONFORMITÉ****EU CONFORMITY  
DECLARATION**

Réf : UE\_MX32\_rev D.I.doc

**II) Directive Européenne CEM 2014/30/UE du 26/02/14: Compatibilité Electromagnétique**  
*The European Directive EMC 2014/30/UE dated from 26/02/14: Electromagnetic Compatibility*Normes harmonisées appliquées :  
*Harmonised applied Standards***EN 50270 : 2015 for type 2****III) Directive Européenne DBT 2014/35/UE du 26/02/14: Basse Tension**  
*The European Directive LVD 2014/35/UE dated from 26/02/14: Low Voltage*Normes harmonisées appliquées :  
*Harmonised applied Standard***EN 61010-1 : 2010****IV) Sécurité Fonctionnelle (Functional Safety)**Normes harmonisées appliquées :  
*Harmonised Applied Standards***EN 50271 :2010**Niveau d'intégrité de Sécurité  
*Safety Integrity Level***SIL 1**

Ce matériel ne doit être utilisé qu'à ce pour quoi il a été conçu et doit être installé en conformité avec les règles applicables et suivant les recommandations du fabricant.  
*This equipment shall be used for the purpose for which it has been designed and be installed in accordance with relevant standards and with manufacturer's recommendations.*

A Arras, le 20/05/2020 / Arras, May 5<sup>th</sup>, 2020AM. Dassonville  
Certification Responsible**Teledyne Oldham Simtronics S.A.S.**  
Z.I. EST - C.S. 20417  
62027 ARRAS Cedex – FRANCE  
Tel. : +33(0)3 21 60 80 80  
www.teledyneGFD.com*Dass*

Page 2 | 2

# **MX32v2**

ANALOG AND DIGITAL CONTROLLER  
USER MANUAL



# 11 Technical Specifications

## 11.1 MX32v2 Controller

Function	
Function	Gas Detection Controller
Number of lines	1 or 2 as per model

Display and indicators	
Display	Back-lit graphic LCD
Status indicators	<ul style="list-style-type: none"> <li>- 7 LEDs for each of the 2 lines</li> <li>- 1 Power On/Off visual indicator</li> <li>- 1 General failure indicator</li> </ul>

Keys	
Selection	5 multifunction soft-touch keys
Alarm release	Dedicated soft-touch key

Alarms	
Limits	Parameter setting by <i>COM 32</i> application
Indicators	6 status LEDs per line (high- and low-range excess, Alarm 3, Alarm 2, Alarm 1, failure)
Internal relay	<ul style="list-style-type: none"> <li>■ 4 fully programmable relays (configuration over <i>COM 32</i>)</li> <li>■ 1 failure relay (non configurable)</li> <li>■ DPCO relays, contact rating: 5A/250Vac-30Vdc</li> <li>■ Screw terminals. Can accept 2.5 mm<sup>2</sup> (14AWG) wire</li> </ul>

**Electrical characteristics**

AC power supply	<ul style="list-style-type: none"> <li>■ 100 to 240Vac, 50/60 Hz</li> <li>■ Maximum 24Vdc output current 1.5A with derating (see next page)</li> </ul>
DC power supply	<ul style="list-style-type: none"> <li>■ 22 to 28Vdc</li> <li>■ Maximum power consumption 3.5A @ 24Vdc. 1.5A per line and rest is for controller consumption</li> </ul>

**Mechanical characteristics**

Installation	■ Wall-mounted format. Indoors use only.
Dimensions (wxhxd)	■ 265 x 266 x 96 mm (10.4 x 10.5 x 3.8 inches)
Weight	■ 1,8 kg (3,97 Lbs)
Ingress Protection	<ul style="list-style-type: none"> <li>■ IP55</li> <li>IP Rating in accordance with ANSI/FM 60079-29-1: IP45"</li> </ul>
Locking	■ 2 toggle latches (one can be locked)

**Environmental characteristics**

Temperature of use	-20 to +50°C, -4°F to +122°F (depending on power consumption)
Storage temperature	-20 to +50°C, -4°F to +122°F
Humidity	5 to 95% relative humidity, non condensing
Pressure, Altitude	Atmospheric pressure +/-10%. 2000m max altitude.
Storage	1 year then risk of data loss and memory time loss

**Standards**

ATEX	Performance according to EN 60079-29-1:16
SIL	SIL 1 according to EN 50271:2010
Electromagnetic Compatibility	as per EN50270:15, industrial type 2
Low Voltage Directive	as per EN61010-1:10
CSA	CAN/CSA-C22.2 No. 0-10; CAN/CSA-C22.2 No. 61010-1-12; UL Std. No. 61010-1 (3rd Edition)
FM	FM Class 3600:2018, FM Class 6320:2018, ANSI/FM-60079-29-1:2019, ANSI/IEC 60529:2004

### Measurement Lines

Digital lines	<ul style="list-style-type: none"> <li>■ 2 maximum</li> <li>■ RS485 Modbus, 9600 Bauds</li> <li>■ 4 wire serial cable, 2 shielded twisted pairs (1 for the line and 1 for communication)</li> </ul>
Analog lines	<ul style="list-style-type: none"> <li>■ 2 maximum</li> <li>■ Input range 4 to 20 mA</li> <li>■ Load resistance 120 Ohms</li> <li>■ Analog transmitter cable 2 or 3 shielded wires</li> </ul>
Wheatstone lines	<ul style="list-style-type: none"> <li>■ 2 maximum</li> <li>■ 3 shielded wire cable</li> </ul>
Nominal voltage	22 to 28 V on external DC
Maximum load	<ul style="list-style-type: none"> <li>■ 1.5A per line with external 24Vdc power supply</li> <li>■ 1A total with internal AC power according to <math>T_{amb}</math> below</li> </ul>
Maximum power supply output power ( $P_{out-max}$ ) depending on ambient temperature $T_{amb}$  (AC power supply only)	<p><math>P_{out-max}</math> requires derating (in order to maintain a constant internal temperature) with <math>0.7W/^{\circ}C</math> above <math>T_{amb} = 30^{\circ}C</math> when powered by internal AC/DC power supply as following:</p> <ul style="list-style-type: none"> <li>■ for <math>T_{amb} \leq +30^{\circ}C</math>, <math>P_{out-max} = 32W</math> <i>(1A external load for both lines)</i></li> <li>■ for <math>+30^{\circ}C \leq T_{amb} \leq +40^{\circ}C</math>, <math>P_{out-max} = 32W</math> to <math>25W</math> <i>(max. 0.71A external load for both lines at <math>+40^{\circ}C</math>)</i></li> <li>■ for <math>+40^{\circ}C \leq T_{amb} \leq +50^{\circ}C</math>, <math>P_{out-max} = 25W</math> to <math>18W</math> <i>(max. 0.42A external load for both lines at <math>+50^{\circ}C</math>)</i></li> </ul>
Cable glands	<ul style="list-style-type: none"> <li>■ 5xM16 cable glands for cables from 4 to 8 mm<sup>2</sup></li> <li>■ 2xM20 cable glands for cables from 6 to 12 mm<sup>2</sup></li> </ul>
Insulation	1500Vac (100-240Vac/24Vdc Power Supply)
Terminals	Screw terminals. Can accept 2.5 mm <sup>2</sup> (14AWG) wire

## 11.2 Relay Module

Function	
Function	Management of 4 or 8 relays from the digital signals issued by the <i>MX32v2</i>
Number of relays	<ul style="list-style-type: none"> <li>■ 4 or 8 relays</li> <li>■ DPCO contact relays</li> </ul>
Relay type	<ul style="list-style-type: none"> <li>■ Bistable</li> <li>■ Energized or de-energized configuration by DIP switches</li> <li>■ Setting of relay parameters by <i>COM 32</i> application</li> </ul>
Nominal load of contacts	2A/250Vac-30Vdc
Consumption	3.5 mA in normal operation
Terminals	<ul style="list-style-type: none"> <li>■ Screw terminals. Can accept 2.5 mm<sup>2</sup> (14AWG) wire</li> <li>■ Removable terminal without powering the line down</li> </ul>
Logic inputs	2 additional logic inputs (dry contacts)
Assembly	DIN rail mounted
Dimensions	125 x 165 x 60 mm

## 11.3 16-Logic Input Module

Function	
Function	Logic input monitoring
Capacity	1 to 16 logic inputs (dry contacts)
Terminals	<ul style="list-style-type: none"> <li>■ Screw terminals. Can accept 2.5 mm<sup>2</sup> (14AWG) wire</li> <li>■ Removable terminal without powering the line down</li> </ul>
Consumption	2 mA in normal operation
Assembly	DIN rail mounted
Dimensions	125 x 165 x 60 mm



## 11.4 8-Analog Input Module

Function	
Function	4-20mA detector or Wheatstone bridge connections
Capacity	1 to 8 independent inputs
Terminals	<ul style="list-style-type: none"> <li>■ Screw terminals. Can accept 2.5 mm<sup>2</sup> (14AWG) wire</li> <li>■ Removable terminal without powering the line down</li> </ul>
Consumption	53 mA max (detector excluded)
Assembly	DIN rail mounted
Dimensions	125 x 165 x 60 mm

## 11.5 4-Analog Output Module

Function	
Function	Generation of 1 to 4 analog values
Capacity	<ul style="list-style-type: none"> <li>■ 4 4-20mA discrete opto-isolated outputs (recopy detector, minimum, maximum, or average of a detector group)</li> <li>■ Resistance of maximum load 500 Ω</li> </ul>
Logic inputs	2 additional logic inputs (dry contacts)
Terminals	<ul style="list-style-type: none"> <li>■ Screw terminals. Can accept 2.5 mm<sup>2</sup> (14AWG) wire</li> <li>■ Removable terminal without powering the line down</li> </ul>
Consumption:	<ul style="list-style-type: none"> <li>■ &lt; 5 mA with the 4 lines at stop</li> <li>■ &lt; 36 mA for an activated line</li> <li>■ &lt; 130 mA for the 4 activated lines</li> </ul>
Assembly	DIN rail mounted
Dimensions	125 x 165 x 60 mm

# **MX32v2**

ANALOG AND DIGITAL CONTROLLER  
USER MANUAL

## 12 RS485 Digital Output

The *MX32v2* units using the *RS485 Modbus* option are equipped with a communication card (code 6451680), which is affixed to the motherboard. This card generates a RS485 output in *Modbus RTU* format.

### 12.1 Card description

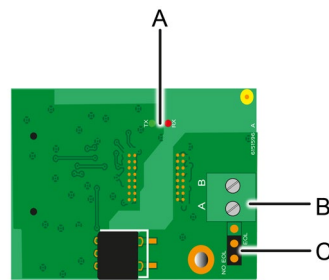

Figure 41: RS485 card

Rep.	Function
A.	Operating LEDs. The <i>Rx</i> LED lights up when a data thread is received. The <i>Tx</i> LED indicates that the card has power and turns off when data is being transmitted out.
B.	Connection terminal: A = Tx or +RS485 B = Rx or -RS485
C.	End Of Line (EOL) resistance. Set the switch to the EOL position for the unit that is the last module in the RS485 network. For other units, set the switch to NO EOL.

The RS485 output can be configured using the *COM 32* software, or using unit menu *2.4 Program >RS485 Port* (see page 45).

## 12.2 Transfer Table

Two types of information can be retrieved *via* the RS485 output:

- Information about sensor configuration;
- Real-time sensor information (measurements, alarms, etc.).

### 12.2.1 1. Access to configuration information

It is possible to access the installation configuration (for example, to access the alarm thresholds or the names of the sensors).

This configuration information is listed in the transfer table from address 0 to address 1999.

The address of the detectors is determined as follows:

- For a digital sensor:  
Sensor address = (line number – 1) x 32 + slave number
- For an analog sensor:  
Sensor address = 256 + line number

Once the sensor address is known, the desired request can be executed by following the transfer table below. For example, to find the instantaneous alarm threshold number 1 for a sensor, read register number 52.

All of the information at addresses 1 to 52 will be accessed. The 52<sup>nd</sup> word corresponds to the expected value.

#### *Example*

Access instantaneous alarm 1 for the sensor located on line 2 at address 2 of unit 2.

A. Determination of the sensor address:  $(2 - 1) \times 32 + 2 = 34$

B. Structure of the *Modbus* request:

- Slave number for the unit (defined by COM 32)      02 = 0x02
- Operating type (03 = read)                              03 = 0x03
- Sensor address    34 = 0x0022
- Number of words to read (see Excel document)      52 = 0x3A
- CRC

Thread: 0x02 0x03 0x00 0x22 0x00 0x3A 0xCRC 0xCRC

### 12.2.2 2. Access to real-time information

Measurement and alarm information from the detectors is listed in the transfer table from address 2000 to 65535. The sensor measurements are available at addresses 2001 to 2264, the sensor statuses are available at addresses 2301 to 2564 (alarm 1, alarm 2, etc.).

**Example**

Access to measurements from the sensor located at line 2 and address 32 of unit n° 2.

A. Determination of the sensor address:  $(2 - 1) \times 32 + 32 = 64$

B. Structure of the *Modbus* request:

- Slave number for the unit (defined by COM 32)    02 = 0x02
- Operating type (03 = read)                            03 = 0x03
- Address of the 1st word                                2000+64 = 0x0810
- Number of words to read                              01 = 0x0001
- CRC

Thread: 0x02 0x03 0x08 0x10 0x00 0x01 0xCRC 0xCRC

**Example**

Access the status of the sensor located at analog input 1 of unit n° 2.

A. Calculation of the table index:  $256 + 1 = 257$

B. Request script:

- Slave number for the unit (defined by COM 32)    02 = 0x02
- Operating type (03 = read)                            03 = 0x03
- Address of the 1st word                                2300 + 57 = 0x09FD
- Number of words to read                              01 = 0x0001
- CRC

Thread: 0x01 0x03 0x09 0xFD 0x00 0x01 0xCRC 0xCRC

## 12.3 Address Table

### 12.3.1 Supervision of the *MX32v2* sensors

All reading requests for the *Modbus* are done *via* function 3. The cartography is shown below:

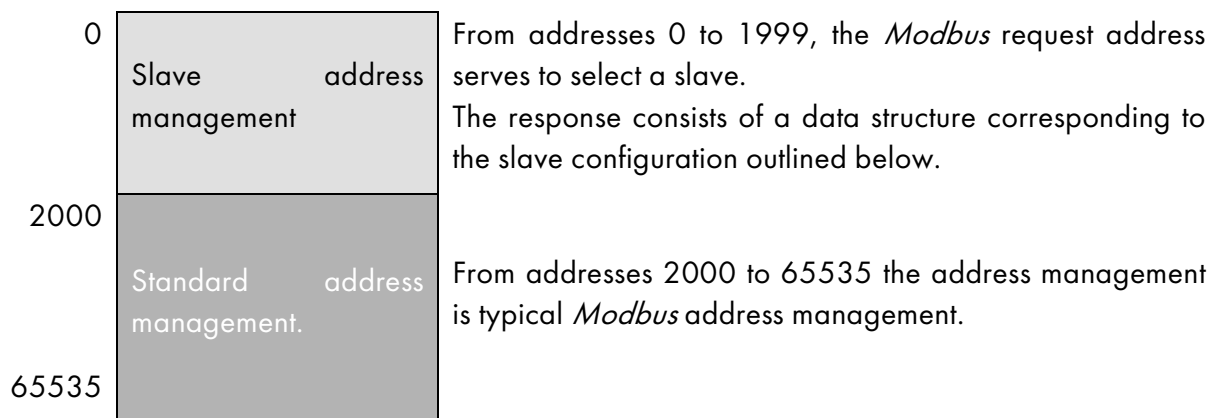

## 12.3.2 Configuring sensors

### Downloading the configuration

The *MX32v2* uses 64 external addresses (line #1 channel #1, to line #2 channel #32) and 2 analog channels for which the addresses are located from 257 to 258.

With the automated system, it is possible to send 66 (64 + 2) *Modbus* requests, where the address field is numbered from 1 to 64 then from 257 to 258 in order to download the configuration of each sensor into the internal memory.

As a result of the operating functionality, it is only possible to repatriate the data of a single sensor for interrogation.

If a sensor is stated at the address mentioned, the *MX32v2* sends the number of data words requested; always from data #1: NAME OF ANALOG SENSOR, at data #x.

If there is no information at the address mentioned, the *MX32v2* sends back 0.

1	Line 1	Sensor 1
32	Line 1	Sensor 32
33	Line 2	Sensor 1
64	Line 2	Sensor 32
257	Analog line #1	
264	Analog line #2	

Sensor addresses

Address	SENSORS [64 + 2]	Nb bytes	Data type										
1	Com sensor	2 X 16	Unicode text (16 bits) 16 characters including the final /0.										
17	Status	2	Start / Stop: if in operation, variable = 1. If stopped, variable = 0.										
18	Gas name	2 x 20	Unicode text (16 bits) 20 characters including the final /0.										
38	Range	2	Value The range is from 1 to 5000. Range X 10 display format. The display format is given in another box.										
39	Display format	2	Coded value.										
40	Unit	2 X 5	Unicode text (16 bits) 5 characters including the final /0.										
45	Abbreviated gas name	2 x 6	Unicode text (16 bits) 6 characters including the final /0. CAUTION, if the first 2 letters = O2: special treatment.										
51	Zone	2	Value	1 to 8									
52	Instantaneous alarm threshold 1	2	Value	-999 to 9999 (real value to be multiplied like the range)									
53	Instantaneous alarm threshold 2	2	Value	-999 to 9999 (real value to be multiplied like the range)									
54	Instantaneous alarm threshold 3	2	Value	-999 to 9999 (real value to be multiplied like the range)									
55	Average alarm threshold 1	2	Value	-999 to 9999 (real value to be multiplied like the range)									
56	Average alarm threshold 2	2	Value	-999 to 9999 (real value to be multiplied like the range)									
57	Average alarm threshold 3	2	Value	-999 to 9999 (real value to be multiplied like the range)									
58	Underscale threshold	2	Value	-999 to 9999 (real value to be multiplied like the range)									

Address	SENSORS [64 + 2]	Nb bytes	Data type										
59	Overscale threshold	2	Value	-999 to 9999 (real value to be multiplied like the range)									
60	Default low threshold	2	Value	-999 to 9999 (real value to be multiplied like the range)									
61	Out of range threshold	2	Value	-999 to 9999 (real value to be multiplied like the range)									
62	Integration time alarm 1	2	Value	15 - 480 min per 1 min step (if not used, put 15 min)									
63	Integration time alarm 2	2	Value..	15 - 480 min per 1 min step (if not used, put 15 min)									
64	Integration time alarm 3	2	Value	15 - 480 min per 1 min step (if not used, put 15 min)									
65	Hysteresis	2	Value	Caution, max = 5% of the range. Always use a positive value and not a percentage.									
66	Alarm active?	2	Configuration per bit	Al active inst, avg: 1, 2, 3.	bit6	bit5	bit4	bit3	bit2	bit1	bit0		
				0 = inactive 1 = active		Alarm avg 3	Alarm avg 2	Alarm avg 1	Alarm inst 3	Alarm inst 2	Alarm inst 1		
67	Acknowl alarm? (Auto/manu) Verification	2	Configuration per bit	Manual acknowl Al 1, 2, 3, verification	bit7	bit6	bit5	bit4	bit3	bit2	bit1	bit0	
				1 = Manual acknowl and 0 = Automatic Acknowl. When the <i>Verification</i> is at 1, the <i>Verification</i> alarm, once activated, is deactivated by stopping the sensor. If the acknowledgment is manual, alarms 1, 2 or 3, once activated, are deactivated using the acknowl button + measurement < alarm.	1 = verification	put 0 mandatory	put 0 mandatory	put 1 mandatory	put 0 mandatory	1=A13 ackmanu	1=A12 ackmanu	1=A11 ackmanu	
68	Increasing or decreasing alarm?	2	Configuration per bit	Al 1, 2, 3 instantaneous or average increasing or decreasing									
				1: increasing 0: decreasing		Alarm avg 3	Alarm avg 2	Alarm avg 1	Alarm inst 3	Alarm inst 2	Alarm inst 1		



### 12.3.3 Acquisitions retrieved cyclically

Real address	SENSOR MEASUREMENTS [256 + 8]	Nb bytes	Data type
<b>If digital</b> Start: 2001 end : 2064 <b>If analog</b> Start: 2257 end : 2258	Sensor measurement	2	Table with 66 signed integer of 16 bits where the measurements are listed at their address. The measurement being whole, the automatic system uses the <i>Display format</i> field to determine where to position the comma.

Real address	ALARMS [256 + 8]	Nb bytes	Data type
<b>If digital</b> Start: 2301 end : 2364 <b>If analog</b> Start: 2557 end : 2558	Table of activated alarms	2	Table with 66 signed integers of 16 bits where the alarms bits are listed at their address. ALARM_1 (bit 0) ALARM_2 (bit 1) ALARM_3 (bit 2) UNDERSCALE (bit 3) OVERSCALE (bit 4) AL_DEFAULT (bit 5) AL_OUT_OF_RANGE (bit 6) L_VERIFICATION (bit 7) Bits 8 to 16 not in use

Real address	INFO	Nb bytes	Data type
2600	CRC32 of the general configuration	2	32 most significant bits option. Note: CRC32 of the entire configuration except the relays (from 0x78000 to 0x7AFFC). If different, re-upload the configuration.
2601		2	32 least significant bits option.
2602	Second counter	2	32 most significant bits option; Note: this counter increases every second and verifies that the unit is active.
2603		2	32 least significant bits option.

# **MX32v2**

ANALOG AND DIGITAL CONTROLLER  
USER MANUAL

## 13 Specific conditions of use and Functional Safety

### 13.1 Reliability data

The *MX32v2* controller is certified according to the European standard EN 50271 “Electrical apparatus for the detection and measurement of combustible gases, toxic gases or oxygen. Requirements and tests for apparatus using software and/or digital technologies”.

Concerning the requirements relative to the software development process, standard EN 50271 specifies a practical approach in order to satisfy the requirements of EN 61508-3 for the safety integrity level SIL 1.

The French Notified Body INERIS certified that the *MX32v2* controller conforms to the necessary requirements and level SIL 1.

Configuration	MTBF (years)	SFF	PFD <sub>avg</sub>	SIL maximum
1 line version	28.6	60%	7.10.10 <sup>-3</sup>	1
2 line version	27.1	60%	7.48.10 <sup>-3</sup>	1
Wheatstone bridge version	25.3	60%	8.02.10 <sup>-3</sup>	1

Ti: 12 months

Mean Time to Repair (MTTR): 48 hours

Recommended operating life: 20 years

### 13.2 Specific Conditions of Use

The safety function of the *MX32v2* is the processing of the signal of the detectors linked to its input. As soon as a measurement reaches a programmed threshold, an audio and visual alarm goes off. Simultaneously, the possible corresponding alarm relay(s) is (are) activated, commanding additional internal or external actions set forth by the user.

In case of system failure, the internal fault relay opens to indicate a fault status (see Figure 8: Internal view (2 line version on top and Bridge version at the bottom)Y).

The fault relay switches over one of the following events:

- Internal error
- Loss of power
- Detector fault
- Connection failure between a measuring line and a detector

The security function is not ensured for 30 seconds after the initialization phase of the installation (power on, reset, restart after configuration change) then during the programmable stabilization time from 30 to 500 seconds.

It is imperative to connect the fault relay and to process this information in any installation where an SIL level is required.

Once per year minimum, it is suggested to voluntarily trigger a fault on one of the measuring lines, by disconnecting a detector, for example, and checking the proper switching of the fault relay.

### 13.3 Specific Conditions of Use for FM

- The MX32 Gas Detection Control Panel complies with the relevant gas detection performance standard listed on the label when connected to a Detector that also has been evaluated to the same gas detection performance standard.
- All unused device openings must be closed using a suitable certified plug.
- Cables with an operating temperature on 70°C minimum (158°F) must be used.
- IP Rating in accordance with ANSI/FM 60079-29-1: IP45"

### 13.4 Specific instructions for the prevention of explosions according to ATEX 2014/34/EU European Directive

*MX32V2* controller is compliant to EN 60079-29-1 standard that specifies the performance requirements of fixed gas detection systems (gas detectors and controllers).

As such, *MX32v2* controller is certified as a safety device and can be used in systems that contribute to reduce the risk of explosion.

The information described below must be taken into account and fulfilled by the site manager. Refer to ATEX 1999/92/EC European Directive on requirements for improving the safety and health of workers potentially at risk from explosive atmospheres.

- It is essential to refer to the instructions of use and commissioning of the gas detectors that are connected to the controller.
- Detectors for flammable gases must also comply with EN 60079-29-1 standard.

- *MX32v2* controller is digitally compatible with OLCT 10N, OLCT 80, OLCT 710, iTrans2, 700 and Meridian gas detectors.
- In the event the user connects a non-TELEDYNE OLDHAM SIMTRONICS brand detector to the *MX32v2* controller, the user must ensure that the detector is compatible with the input characteristics of the controller, so that the information delivered by the detector will be properly interpreted (see transfer curve on the following page). In addition, the controller must provide sufficient supply voltage, taking into account voltage drops in the cable.
- Highest alarm set point for flammable gases shall not exceed 60% LEL and shall be of a latching type.
- In normal operation mode and without any time delay that the user could have programmed, *MX32v2* response time is less than 2 seconds regardless of the number of inputs/outputs.
- Time delay and relay operation settings (see voir Alarm Thresholds and Relays, page 17) is the responsibility of the user.
- Over-range (flammable gases)

---

As soon as gas concentration exceeds 100% LEL, *MX32v2* stores the over-range condition and displays *>100% LEL*. The concerned channel goes into alarm and fault condition and OVS (*OVERSCALE*) and FAULT (*FAULT*) visual indicators are lit.



Alarm reset is manual and under the responsibility of the user who must follow the site-specific safety guidelines. Over-range condition can only be deactivated by switching off the detector via the maintenance menu providing the gas concentration is below the alarm threshold.

---

- *MX32v2* controller must not be exposed to mechanical vibrations and must be installed in a non-hazardous area.
- With respect to installation in explosive atmospheres, the electrical installation must comply with the regulation in force, in particular EN 60079-14 and EN 6079-17 standards (current editions) and, if necessary, additional requirements of domestic or national regulations that apply to the place of installation.

## 13.5 Connecting detectors other than *TELEDYNE OLDHAM SIMTRONICS* detectors to the *MX32v2* controller

Any user wishing to use detectors other than TELEDYNE OLDHAM SIMTRONICS detectors must ensure that they are compatible with the controller, in order the complete installation to be considered as a safety device.

### 13.5.1 Transfer table

The following table shows the controller status depending on the detector analog signal output. In the event the user connects a non-*TELEDYNE OLDHAM SIMTRONICS* brand detector to the *MX32v2* controller, the user must ensure that the detector is compatible with the input

characteristics of the controller, so that the information delivered by the detector will be properly interpreted. In addition, the controller must provide sufficient supply voltage, taking into account voltage drops in the cable.

Detector signal output	MX32v2 Status
0 to 2.4 mA	Fault
>2.4 to 21.6mA	Measurement
>21.6 mA	Over Range Fault

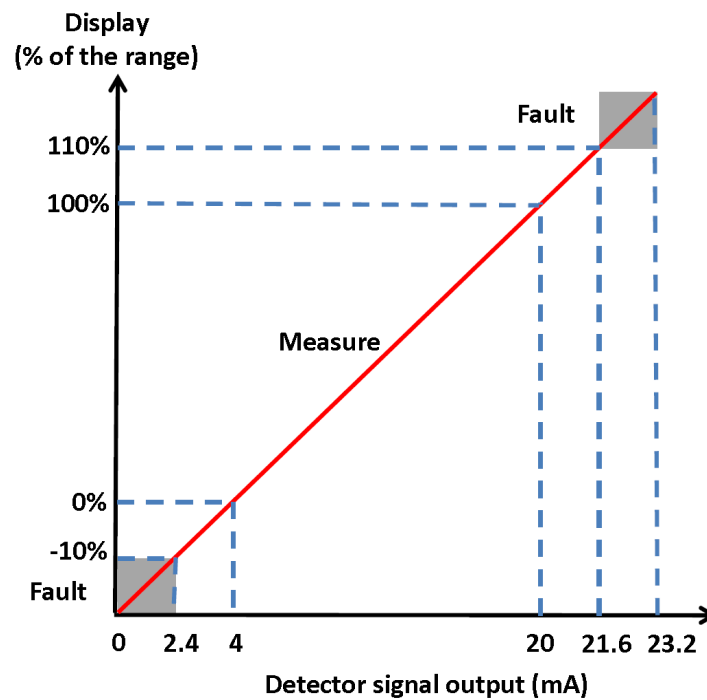





**TELEDYNE**  
**OLDHAM SIMTRONICS**  
Everywhereyoulook™



**AMERICAS**

4055 Technology Forest Blvd  
The Woodlands  
TX 77381, USA  
Tel.: +1-713-559-9200

**EMEA**

Rue Orfila  
Z.I. Est – CS 20417  
62027 ARRAS Cedex,  
France  
Tel.: +33 (0)3 21 60 80 80

**ASIA PACIFIC**

Room 2722,  
No. 51 Jinzang Road  
Shanghai Free Trade Zone  
China  
Tel.: +86-134-8229-5057

[www.teledynegasandflamedetection.com](http://www.teledynegasandflamedetection.com)



© 2021 Teledyne Oldham Simtronics. All right reserved.

NP32V2 EN Revision E.O. / January 2021