

# 700 FP Series

## Combustible Gas Detector



**OLCT 700**



**OLCT 710**

Part Number: NP700FPIMEN  
Revision: C.0

Copyright © April 2016 by Oldham S.A.S.

All rights reserved. No reproduction of all or part of this document, in any form, is permitted without the written consent of Oldham S.A.S.

All of the information that is provided in this document is accurate to the best of our knowledge.

As a result of continuous research and development, the specifications of this product may be changed without prior notice.

Oldham S.A.S.  
Rue Orfila  
Z.I. Est – CS 20417  
F – 62027 ARRAS Cedex  
Tel: +33 (0)3 21 60 80 80  
Fax: +33 (0)3 21 60 80 00

# Table of Contents

<b>1. Introduction .....</b>	<b>1</b>
1.1 Description .....	1
1.2 Modular Mechanical Design .....	3
1.3 Plug-in Replaceable Sensor .....	4
<b>2. Installation .....</b>	<b>5</b>
2.1 ATEX Operational Guidelines for Safe Use .....	5
2.2 Functional Safety (SIL 2) .....	6
2.3 Detector Placement.....	6
2.4 Sensor Contaminants and Interference .....	7
2.5 Mounting Installation .....	7
2.6 Electrical Installation.....	8
2.7 Field Wiring .....	9
2.8 Initial Start Up.....	12
<b>3. Operation .....</b>	<b>13</b>
3.1 Programming Magnet Operating Instructions .....	13
3.2 Operator Interface.....	14
3.3 Normal Operation.....	15
3.4 Calibration Mode (AutoZero and AutoSpan).....	16
3.5 Program Mode.....	18
3.6 Program Features.....	24
<b>4. RS-485 Modbus™ Protocol .....</b>	<b>28</b>
<b>5. Service and Maintenance .....</b>	<b>30</b>
5.1 Calibration Frequency .....	30
5.2 Visual Inspection.....	30
5.3 Condensation Prevention Packet .....	30
5.4 Replacement of Plug-in Combustible Gas Sensor.....	30
<b>6. Troubleshooting Guide .....</b>	<b>32</b>
<b>7. Appendix .....</b>	<b>36</b>
7.1 Specifications .....	36
7.2 Spare Parts, Detector Accessories, Calibration Equipment.....	38
7.3 OLCT 700/710 FP Drawings .....	39
<b>8. EC Declaration of conformity .....</b>	<b>42</b>
<b>9. Revision Log.....</b>	<b>44</b>

## Table of Figures

Figure 1: Sensor Cell Construction .....	1
Figure 2: Wheatstone Bridge.....	2
Figure 3: Response Curves.....	2
Figure 4: Detector Assembly Breakaway.....	3
Figure 5: OLCT 700 Assembly Front View.....	3
Figure 6: OLCT 710 Front View.....	4
Figure 7: OLCT 700/710 FP Replaceable Sensor Cell.....	4
Figure 8: ATEX Approval Label.....	5
Figure 9: Outline and Mounting Dimensions .....	8
Figure 10: Typical Installation .....	9
Figure 11: Detector Wire Connections.....	11
Figure 12: Magnetic Programming Tool.....	13
Figure 13: Magnetic Programming Switches .....	13
Figure 14: OLCT 700/710 FP Software Flowchart.....	15
Figure 15: Sensor Assembly.....	30
Figure 16: Plug-in Sensor (Bottom View).....	32

## List of Tables

Table 1: Wire Gauge vs. Distance.....	10
Table 2: Gas/Cal Factors .....	21
Table 3: Modbus™ Registers.....	28
Table 4: Modbus™ Special Registers .....	29

Thank you for choosing this OLDHAM instrument. All of the necessary actions have been taken in order to ensure your complete satisfaction with this equipment. It is important that you read this entire manual carefully and thoroughly.

## Limitation of Reliability

- OLDHAM shall not be held responsible for any damage to the equipment or for any physical injury or death resulting in whole or in part from the inappropriate use, installation, or storage of the equipment, which is the result of not complying with the instructions and warnings, and/or with the standards and regulations in force.
- OLDHAM does not support or authorise any business, person, or legal entity in assuming responsibility on behalf of OLDHAM, even though they may be involved in the sale of OLDHAM products.
- OLDHAM shall not be responsible for any damage, direct or indirect, or for damages and interest, direct or indirect, resulting from the sale and use of any of its products **UNLESS SUCH PRODUCTS HAVE BEEN DEFINED AND CHOSEN BY OLDHAM FOR THE USE THAT THEY ARE INTENDED.**

## Ownership clauses

- The drawings, specifications, and information herein contain confidential information that is the property of OLDHAM.
- This information shall not, either in whole or in part, by physical, electronic, or any other means whatsoever, be reproduced, copied, divulged, translated, or used as the basis for the manufacture or sale of OLDHAM equipment, or for any other reason **without the prior consent of OLDHAM.**

## Warning

- This is not a contractual document. In the best interest of its customers and with the aim of improving performance, **OLDHAM** reserves the right to alter the technical features of its equipment without prior notice.
- **READ THESE INSTRUCTIONS CAREFULLY BEFORE THE FIRST USAGE:** these instructions should be read by all persons who have or will have responsibility for the use, maintenance, or repair of the instrument.
- This instrument shall only be deemed to be in conformance with the published performance if used, maintained, and repaired in accordance with the instructions of OLDHAM by OLDHAM personnel or by personnel authorised by OLDHAM.

## Guarantee

- Under normal conditions of use and on return to the factory, sensors and electronics parts are guaranteed for 2 years from date of shipment; excluding consumables as dessiccant, filters, etc.

## Destruction of the equipment



**European Union (and EEA) only.** This symbol indicates that, in conformity with directive DEEE (2002/96/CE) and according to local regulations, this product may not be discarded together with household waste. It must be disposed of in a collection area that is set aside for this purpose, for example at a site that is officially designated for the recycling of electrical and electronic equipment (EEE) or a point of exchange for authorized products in the event of the acquisition of a new product of the same type as before.

This page has been left blank  
intentionally

# 1. Introduction

## 1.1 Description



Oldham OLCT 700 FP combustible gas detectors are non-intrusive “Smart” detectors designed to detect and monitor combustible gases in air. Range of detection is 0-100% LEL. The detector features an LED display of current reading, fault and calibration status. The unit is equipped with standard analog 4-20mA and Modbus™ RS-485 outputs. A primary feature of the detector is its method of automatic calibration, which guides the user through each step via fully scripted instructions displayed on the LED display.

The microprocessor-supervised electronics are packaged in an encapsulated module and housed in an explosion proof casting. The unit includes a 4 character alpha/numeric LED used to display detector readings, and the detector’s menu driven features when the hand-held programming magnet is used.

The OLCT 710 is made of an OLCT 700 attached to a flameproof junction that includes terminal blocks and an optional surge protection board. The complete assembly is flameproof certified « Ex d » and carries ATEX approval (see section 2.1 for safety instructions in Explosive Atmosphere).

The OLCT 700 is flameproof certified and carries ATEX approval. The OLCT 700 shall be attached to an increased safety certified junction box when used in an ATEX zone (see section 2.1 for safety instructions in Explosive Atmosphere).

### 1.1.1 Catalytic Bead (Pellistor) Sensor Technology

The sensor technology is a poison-resistant catalytic bead type. Catalytic bead sensors show a strong response to a long list of combustible gases. The sensor is supplied as a matched-pair of detector elements mounted in a plug-in replaceable module. One bead is a catalytically active detector and the other is a non-active reference detector. Each detector consists of a fine platinum wire coil embedded in aluminum oxide. A catalytic mixture is applied to the active detector while the reference detector is treated so that oxidation of the gas does not occur. The technique is referred to as non-selective and may be used to monitor most any combustible gas. Oldham catalytic bead sensors are specifically designed to be resistant to poisons such as sulfides, chlorides, and silicones. The sensors are characteristically stable and capable of providing reliable performance for periods exceeding 5 years in most industrial environments.

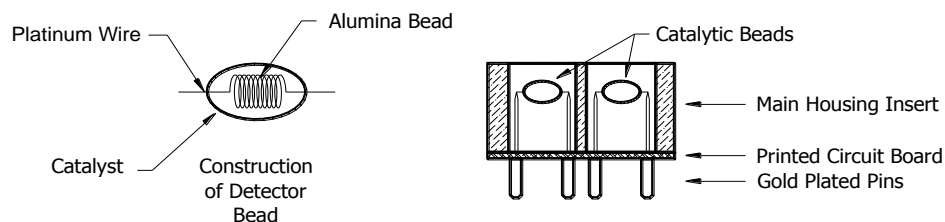
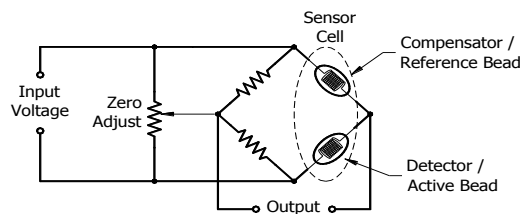

**Figure 1:** Sensor Cell Construction

### 1.1.2 Principle of Operation

Method of detection is by diffusion/adsorption. Air and combustible gases pass through a sintered stainless steel filter and contact the heated surface of both the active and reference detectors. The surface of the active detector promotes oxidation of the combustible gas molecules while the reference detector has been treated not to support this oxidation. The reference detector serves as a means to maintain zero stability over a wide range of temperature and humidity.

When combustible gas molecules oxidize on the surface of the active detector, heat is generated, and the resistance of the detector changes. Electronically, the detectors form part of a balanced bridge circuit. As the active detector changes in resistance, the bridge circuit unbalances. This change in output is conditioned by the amplifier circuitry, which is an integral part of the detector design. The response and clearing characteristics of the detector are rapid and provide for the continuous and accurate monitoring of ambient air conditions.



**Figure 2: Wheatstone Bridge**

### 1.1.3 Performance Characteristics

The detector elements maintain good sensitivity to combustible gas concentrations in the Lower Explosive Limit (LEL) range, as shown in the response curves in Figure 3. However, for gas concentrations significantly above the LEL range (100% LEL = 5% by volume Methane), the bridge output begins to decrease. Ambiguous readings above the LEL range dictate that alarm control logic be of the latching type, wherein alarms are held in the “ON” position until reset by operations personnel.

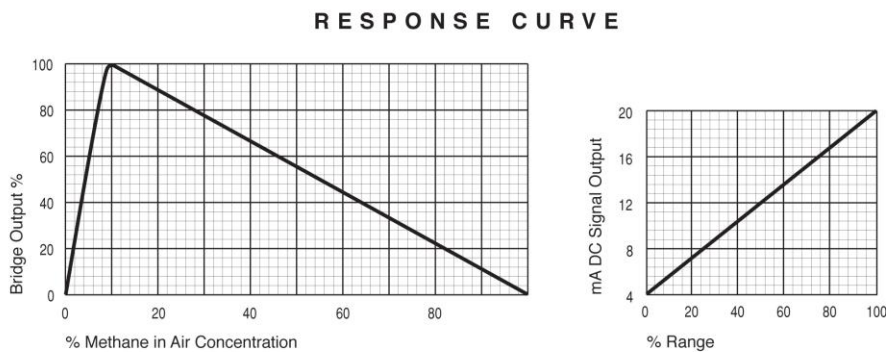
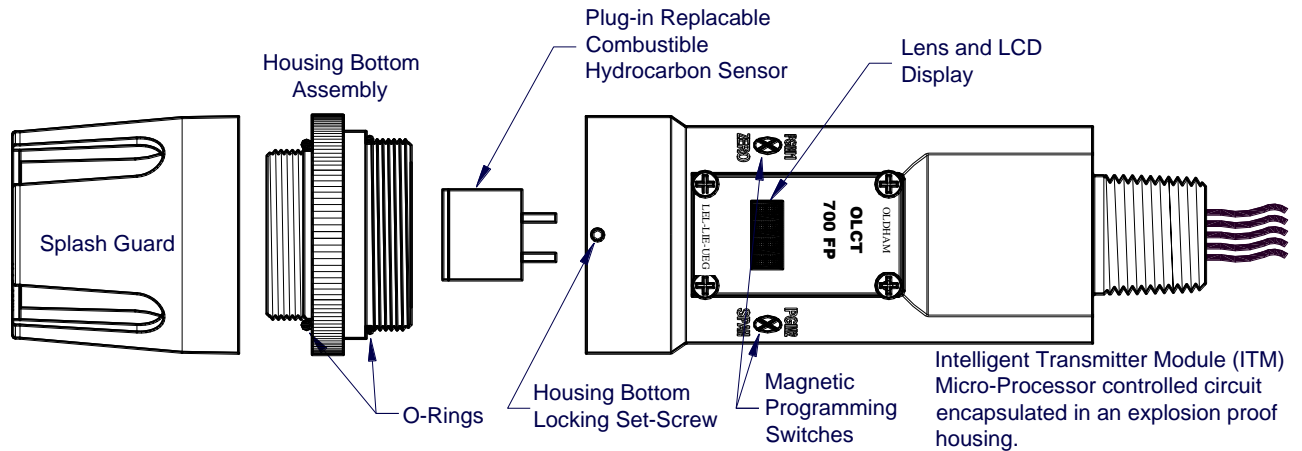

**Figure 3: Response Curves**



## 1.2 Modular Mechanical Design

The OLCT 700 FP Detector Assembly is completely modular and made up of four parts (See Figure below):



**Figure 4:** Detector Assembly Breakaway

- 1) OLCT 700 FP Intelligent Transmitter Module (ITM). The ITM is a fully encapsulated microprocessor-based package that accepts a plug-in field replaceable sensor. Circuit functions include LED display, magnetic programming switches, a linear 4-20mA DC output, and a Modbus™ RS-485 output. Magnetic program switches allow non-intrusive operator interface.
- 2) Field Replaceable Plug-in Catalytic Gas Sensor
- 3) Housing Bottom Assembly (contains the Housing Bottom, Flame Arrestor, Retaining Ring, and rubber O-Rings)
- 4) Splash Guard.

NOTE: All metal components are constructed from electro-polished 316 Stainless Steel in order to maximize corrosion resistance in harsh environments.

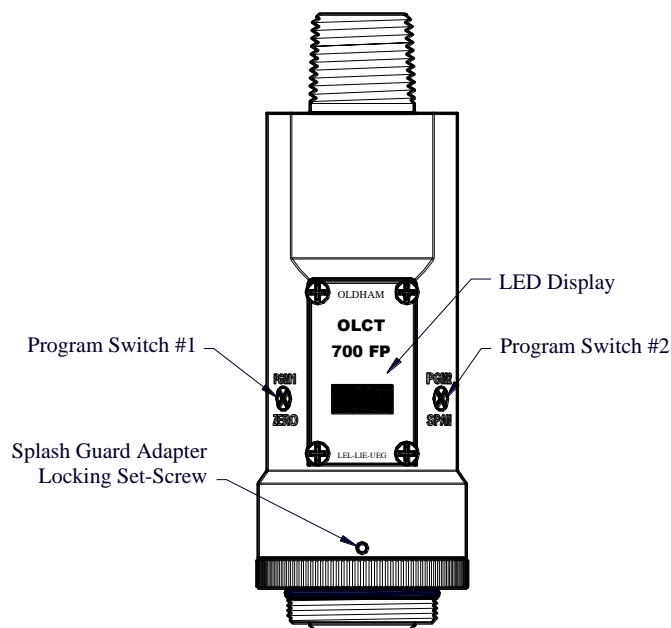

**Figure 5:** OLCT 700 Assembly Front View

OLCT 710 is made of an OLCT 700 attached to a flameproof certified junction box for terminal connections.

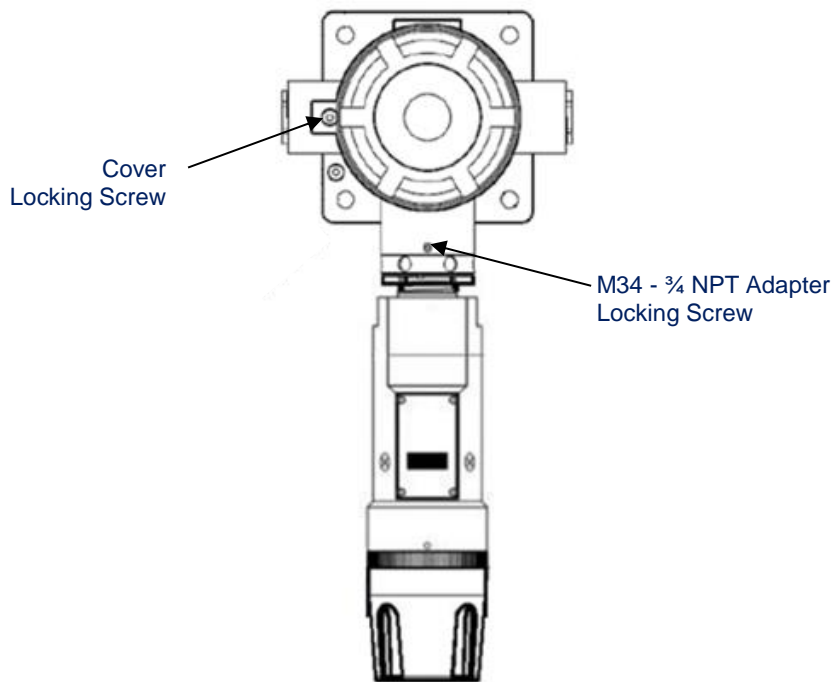

**Figure 6:** OLCT 710 Front View

### 1.3 Plug-in Replaceable Sensor

The combustible gas sensor is a poison-resistant and field proven design. It is packaged as true plug-in replaceable type sensor with over-sized gold-plated connections that eliminate corrosion problems. It can be accessed and replaced in the field very easily by releasing the locking screw and unthreading the housing bottom. The combustible gas sensor has an infinite shelf life, and is supported by a 2-year warranty. The expected service life is 3-5 years.



**Figure 7:** OLCT 700/710 FP Replaceable Sensor Cell

## 2. Installation

### 2.1 ATEX Operational Guidelines for Safe Use

OLCT 700/710 conforms to the requirements of European Directive ATEX 94/9/CE relating to explosive Gas atmospheres.

The information given in the following sections should be respected and taken into account by the manager of the site where the equipment is installed. As far as the aim of improving the health and safety of workers who are exposed to the risks of explosive atmospheres is concerned, refer to European Directive ATEX 1999/92/CE.

1. Install detector only in areas with classifications matching with those described on the ATEX approval label. Follow all warnings listed on the label.

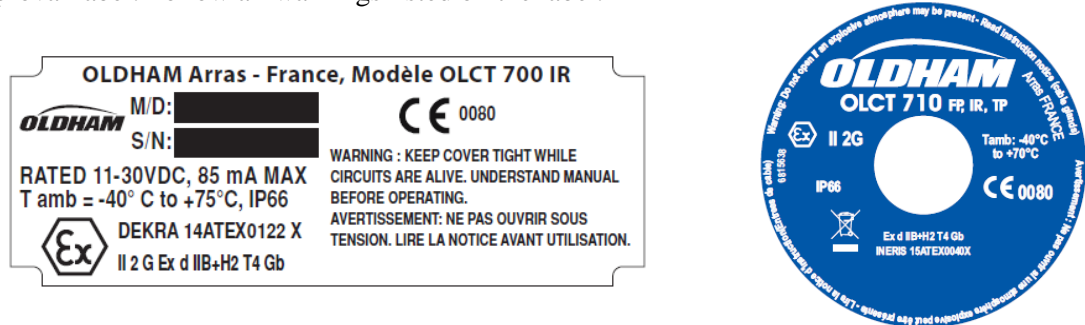

**Figure 8:** ATEX Approval Label

2. Cable glands shall be flameproof certified («Ex d») for use in explosive atmospheres. Ingress Protection will be greater or equal to IP66. Cable glands will be mounted according to IEC/EN 60079-14 standard, edition in force, and to additional requirements from local standards. They shall be of M20x1.5 and the engagement shall be 5 threads at least. Cables used shall have an operating temperature range equal or greater than 80 °C.
3. The threaded joints may be lubricated to maintain flameproof protection. Only non-hardening lubricants or non-corrosive agents having no volatile solvents may be used.
4. Verify a good ground connection between the junction box and earth ground.
5. Ensure the Housing Bottom is threaded tightly to the Intelligent Transmitter Module. The locking setscrew (M3.5 x 0.6 6g6h Stainless Steel Allen set screw cup point with yield strength of greater than 40,000 PSI, typical 80,000 PSI) should then be tightened down to keep the Housing Bottom from being inadvertently removed or from becoming loose under vibration. The locking setscrew ensures that Housing Bottom is only removable by authorized personnel with the use of special tools. A M1.5 Allen Wrench is required. If screw requires replacement, only an identical screw may be used.
6. Removal of the Housing Bottom violates the Ex d protection method and hence power must be removed from the detector prior its safe removal.
7. Proper precautions should be taken during installation and maintenance to avoid the build-up of static charge on the plastic components of the detector. These include the splashguard and splashguard adapter.
8. When used in ATEX zone, OLCT 700 shall be attached to increased safety certified junction box only.

## 2.2 Functional Safety (SIL 2)

Refer to safety user manual NP700IRSMEN

## 2.3 Detector Placement

Selection of detector location is critical to the overall safe performance of the product. Five factors play an important role in selection of detector locations:

- (1) Density of the gas to be detected
- (2) Most probable leak sources within the industrial process
- (3) Ventilation or prevailing wind conditions
- (4) Personnel exposure
- (5) Maintenance access

### Density

Placement of detectors relative to the density of the target gas is such that detectors for the detection of heavier than air gases should be located within 4 feet of grade as these heavy gases will tend to settle in low lying areas. For gases lighter than air, detector placement should be 4-8 feet above grade in open areas or in pitched areas of enclosed spaces.

---

**NOTE:** Methane and Hydrogen are lighter than air. Most other combustible gases are heavier than air. Compare the molecular weight, density, or specific gravity of the target gas(es) with that of air to determine appropriate placement.

---

### Leak Sources

The most probable leak sources within an industrial process include flanges, valves, and tubing connections of the sealed type where seals may either fail or wear. Other leak sources are best determined by facility engineers with experience in similar processes.

### Ventilation

Normal ventilation or prevailing wind conditions can dictate efficient location of gas detectors in a manner where the migration of gas clouds is quickly detected.

### Personnel Exposure

The undetected migration of gas clouds should not be allowed to approach concentrated personnel areas such as control rooms, maintenance or warehouse buildings. A more general and applicable thought toward selecting detector location is combining leak source and perimeter protection in the best possible configuration.

### Maintenance Access

Consideration should be given to providing easy access for maintenance personnel. Consideration should also be given to the consequences of close proximity to contaminants that may foul the sensor prematurely.

---

**NOTE:** In all installations the gas detector should point straight down (refer to **Erreur ! Source du renvoi introuvable.**). Improper detector orientation may result in false readings and permanent detector damage.

---

### Additional Placement Considerations

The detector should not be positioned where it may be sprayed or coated with surface contaminating substances. Painting detector assemblies is prohibited.

Although the detector is designed to be RFI resistant, it should not be mounted in close proximity to high-powered radio transmitters or similar RFI generating equipment.

When possible, mount the detector in an area void of high wind, accumulating dust, rain or splashing from hose spray, direct steam releases, and continuous vibration. If the detector cannot be mounted away from these conditions then make sure the Oldham Harsh Environment Splashguard accessory is used (PN DET-943-002273-000).

Do not mount in locations where temperatures will exceed the operating temperature limits of the detector. Where direct sunlight leads to exceeding the high temperature-operating limit, use a sunshade to help reduce temperature.

## 2.4 Sensor Contaminants and Interference

Oldham OLCT 700/710 FP combustible gas detectors may be adversely affected by exposure to certain airborne substances. Loss of sensitivity or corrosion may be gradual if such materials are present in sufficient concentrations.

The performance of the detector elements may be temporarily impaired during operation in the presence of substances described as inhibitors. Inhibitors are usually volatile substances containing halogen compounds. Inhibitors include halide compounds such as Cl<sub>2</sub>, ClO<sub>2</sub>, F<sub>2</sub>, HF, HCl, Br<sub>2</sub>, vinyl chloride, and methyl chloride. Inhibition is typically a temporary effect and the detectors generally recover after short periods of operation back in clean air.

Some background gases may act as poisoning agents and have a more damaging effect on the sensor. Although the sensor is designed to be poison resistant, it does have physical limits. Poisoning gases deactivate the active detector's catalytic ability and cause a permanent reduction in the span sensitivity. Examples of typical poisons are: silicone oils and greases, siloxanes (HMDS), H<sub>2</sub>S, anti-knock petrol additives, and phosphate esters. Activated carbon filters can be used to provide additional protection from poisoning in most cases.

The presence of such inhibitors and poisons in an area does not preclude the use of this sensor technology, although it is likely that the sensor lifetime will be shorter as a result. Use of this detector in these environments may require more frequent calibration checks to ensure safe system performance.

## 2.5 Mounting Installation

- The installation should meet all the regulations currently in force for installations in explosive atmospheres, in particular the standards IEC/EN 60079-14 and IEC/EN 60079-17 (whichever editions are in force) or in accordance with other national standards.
- The equipment is allowed in ATEX zones 1 and 2 for ambient temperatures ranging from -40 °C to +75 °C. Understand that operating temperature range may be different (see technical specifications).
- The sensor shall always be in contact with ambient air. Therefore,
  - do not cover the detector
  - do not paint detector assemblies
  - avoid dust accumulation

The OLCT 700/710 IR should be vertically oriented so that the detector points straight downward (see Figure below). Installation of the enclosure shall be secured with 4 x M6 screws and the appropriate plugs for the supporting material. There is an adaptor plate for ceiling installation (PN 6322420).

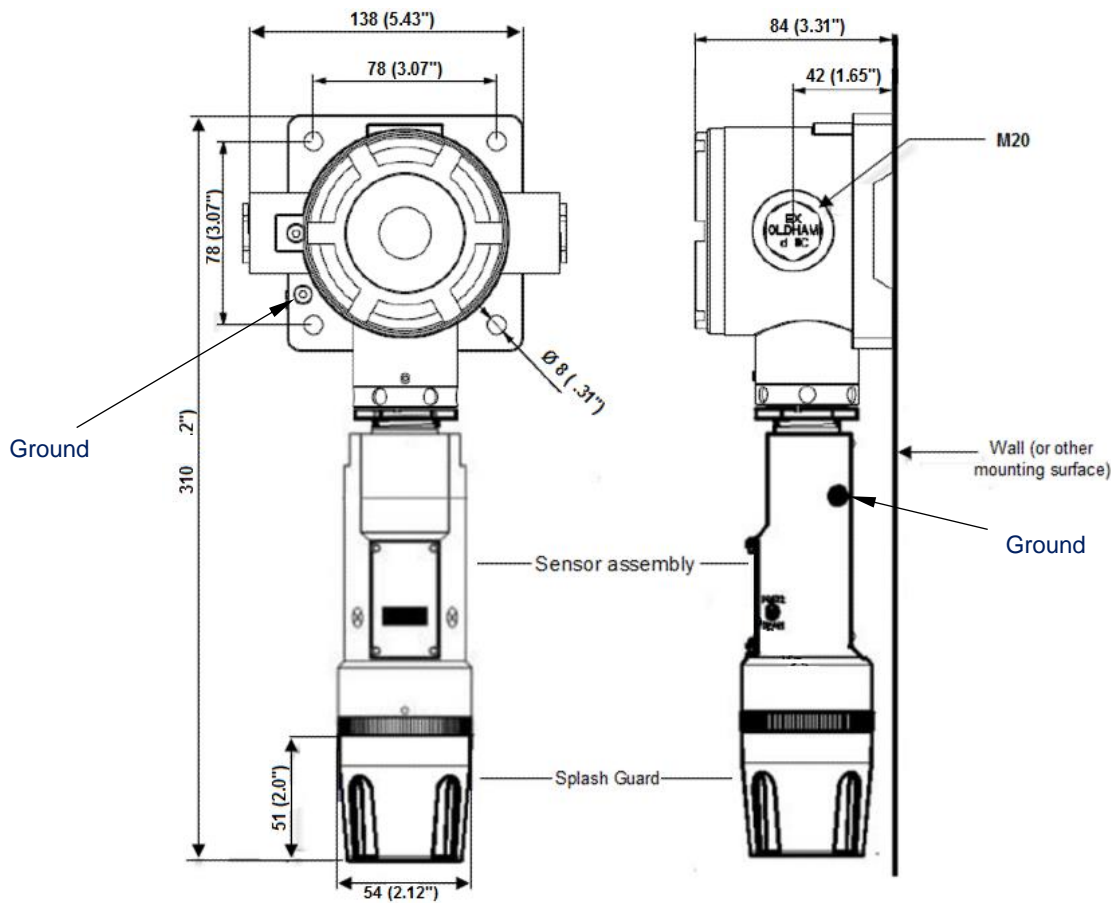

**Figure 9:** Outline and Mounting Dimensions

When mounting on a pole, secure the Junction Box to a suitable mounting plate and attach the mounting plate to the pole using U-Bolts (Pole-Mounting brackets for Oldham J-box accessories are available separately).

## 2.6 Electrical Installation

The installation should meet all the regulations currently in force for installations in explosive atmospheres, in particular the standards IEC/EN 60079-14 and IEC/EN 60079-17 (whichever editions are in force) or in accordance with other national standards. OLCT 700 and OLCT 710 are certified for use in ATEX zones 1 and 2, group IIB+H2, T4.

Proper electrical installation of the gas detector is critical for conformance to Electrical Codes and to avoid damage due to water leakage. Refer to Figure 10 and Figure 11 for proper electrical installation.

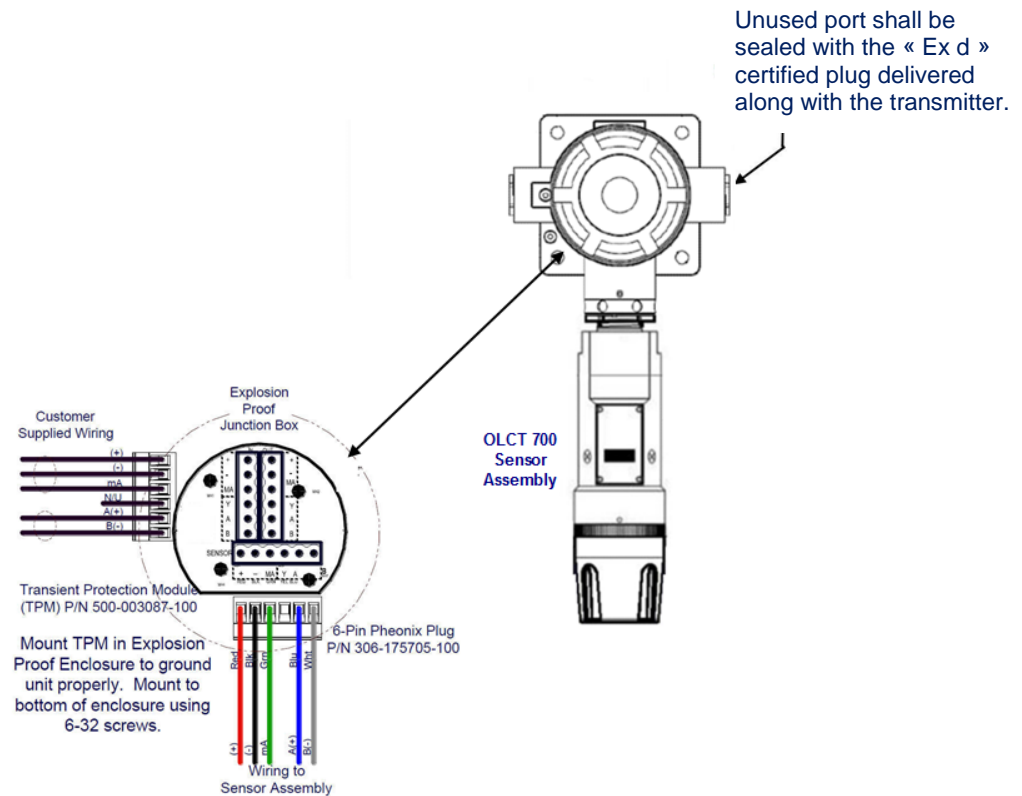

**Figure 10: Typical Installation**

---

**NOTE:** The Oldham Warranty does not cover water damage resulting from water leaking into the enclosure. However, since the electronics are 100% epoxy encapsulated, only the wire terminations could get wet. Moisture could cause abnormal operation and possibly corrosion to the terminal connections, but permanent damage to the detector would not be expected.

---



---

**NOTE:** Unused port should be blocked with the M20x1.5 male plug supplied by Oldham (ATEX and 'Ex d IIC' certified). The engagement shall be 5 threads at least.

---

## 2.7 Field Wiring

Oldham OLCT 700/710 FP combustible gas detector assemblies require three conductor connections between power supplies and host electronic controller's 4-20mA output, and 2 conductor connections for the Modbus™ RS-485 serial interface. Wiring designations are:

- + (24VDC)
- - (0V)
- mA (detector signal)
- A (+) Modbus™ RS-485
- B (-) Modbus™ RS-485

Maximum wire length between detector and 24VDC source is shown in the Table below. Maximum wire size for termination in the Oldham J-Box accessory is 14AWG.

Max loop load resistance between green and black wire (analog signal output) is 500 ohms. Minimum loop load resistance between green and black wire is 100 ohms. This is considers wire diameter, wire length, max operating temperature and selected termination resistor.



**Table 1: Wire Gauge vs. Distance**

AWG	Wire Dia.	Cross Section	Meters/Feet	Over-Current Protection
22	0,65 mm	0,32 mm <sup>2</sup>	700/2080	3A
20	0,8 mm	0,5 mm <sup>2</sup>	1120/3350	5A
18	1,0 mm	0,8 mm <sup>2</sup>	1750/5250	7A
16	1,3 mm	1,3 mm <sup>2</sup>	2800/8400	10A
14	1,6 mm	2 mm <sup>2</sup>	4480/13440	20A

**NOTE 1:** Wiring table is based on stranded tinned copper wire and is designed to serve as a reference only.

**NOTE 2:** Shielded cable is required for installations where cable trays or conduit runs include high voltage lines or other possible sources of induced interference. Separate conduit or tray runs are highly recommended in these cases.

**NOTE 3:** The supply of power should be from an isolated source with over-current protection as stipulated in table.

### 2.7.1 Cable Preparation

**NOTE:** It is essential that the instructions provided by the manufacturer of the cable gland are followed and the braid is correctly connected.

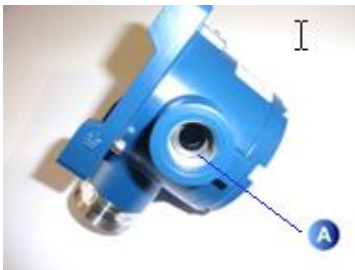

1 - Remove the rubber pot and the two metal washers (A)

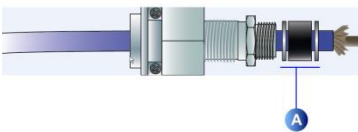

2 - Arrange the cable as shown in the picture



3 - Arrange the braid as shown in the picture. Avoid creating "pig tails"





4 - Insert the part back into the OLCT 710

### 2.7.2 Terminal Connections



**CAUTION:** Do not apply System power to the detector until all wiring is properly terminated and opening are properly closed.

- a) Remove the junction box cover. Identify the terminal blocks for customer wire connections (see Figure 11).

**NOTE :** To remove the cover, tighten the locking screw before unscrewing the cover

Locking screw

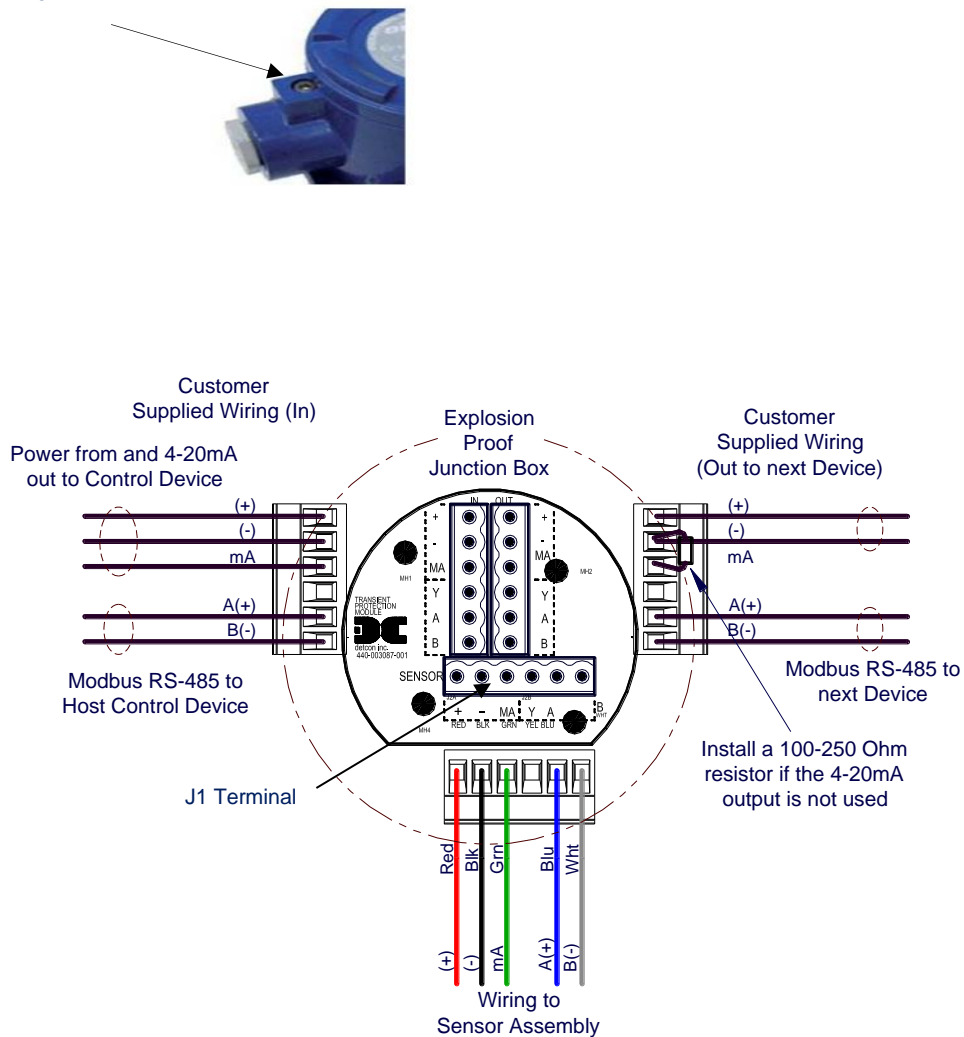

**Figure 11: Detector Wire Connections**

- b) Observing correct polarity, terminate the 3-conductor 4-20mA field wiring (+, -, mA) to the detector assembly wiring in accordance with the detail shown in Figure 11.

**NOTE: If the 4-20mA output is not being used, the Green wire from the detector *must* be connected to the Black wire at the (-) terminal on the Transient Protection Module to ensure RS-485 communication is not disrupted by a 4-20mA Fault.**

- c) If applicable, terminate the RS-485 serial wiring. Use the second plug (Out) as termination point on the customer side to facilitate a continuous RS-485 serial loop.

The RS-485 (if applicable) requires 24 gauge, two conductor, shielded, twisted pair cable between detector and host controller. General Cable Commodore part number ZO16P0022189 is recommended.

**NOTE: Install a 120 ohm resistor across A & B terminals on the last detector in the serial loop.**

- d) Screw the cover firmly and loosen the locking screw until it reaches the cover.

## 2.8 Initial Start Up

Upon completion of all mechanical mounting and termination of all field wiring, apply system power in the range of 11.5-30VDC (24VDC typical) and observe the following normal conditions:

- a) OLCT 700/710 FP display reads “0”, and no fault messages are flashing.
- b) A temporary upscale reading may occur as the detector heats up. This upscale reading will decrease to “0” within 1-2 minutes of power-up, assuming there is no combustible gas in the area of the detector.

**NOTE: The 4-20mA signal is held constant at 4mA for the first two minutes after power up.**

### 2.8.1 Initial Operational Tests

After a warm up period of 1 hour, the detector should be checked to verify sensitivity to combustible gas.

#### Material Requirements

- PN DET-613-120000-700 OLCT 700/710 Series Splash Guard with integral Cal Port OR PN DET-943-000006-132 Threaded Calibration Adapter
  - PN 18108011 Span Gas; 2.5% vol. methane
- a) Attach the calibration adapter to the threaded detector housing. Apply the test gas at a controlled flow rate of 0.5l/min. Allow 1-2 minutes for the reading to stabilize. Observe that during the 1-2 minutes the OLCT 700/710 display increases to a level near that of the applied calibration gas value.
- b) Remove test gas and observe that the display decreases to “0”.

Initial operational tests are complete. Oldham OLCT 700/710 FP combustible gas detectors are factory calibrated prior to shipment, and should not require significant adjustment on start up. However, it is recommended that a complete calibration test and adjustment be performed 16 to 24 hours after power-up. Refer to zero and span calibration instructions in Section 3.4.

## 3. Operation

### 3.1 Programming Magnet Operating Instructions

The Operator Interface of the OLCT 700/710 FP Series gas detectors is accomplished via two internal magnetic switches located to either side of the LED display (see Figure 13). The two switches, labeled “PGM1” and “PGM2”, allow for complete calibration and configuration and thereby eliminate the need for area de-classification or the use of hot permits.



**Figure 12:** Magnetic Programming Tool

The magnetic programming tool (Figure 12) is used to operate the magnetic switches. Switch action is defined as momentary contact, 3-second hold, and 10-second hold (hold times are defined as the time from the point when the arrow prompt “◀” appears.) For momentary contact use, the programming magnet is briefly held over a switch location. The 3 and 10 second holds are generally used to enter calibration/program menus and save new data. The momentary contact is generally used to move between menu items and to modify set-point values. Arrows (“◀” and “▶”) are used on the LED display to indicate when the magnetic switches are activated.

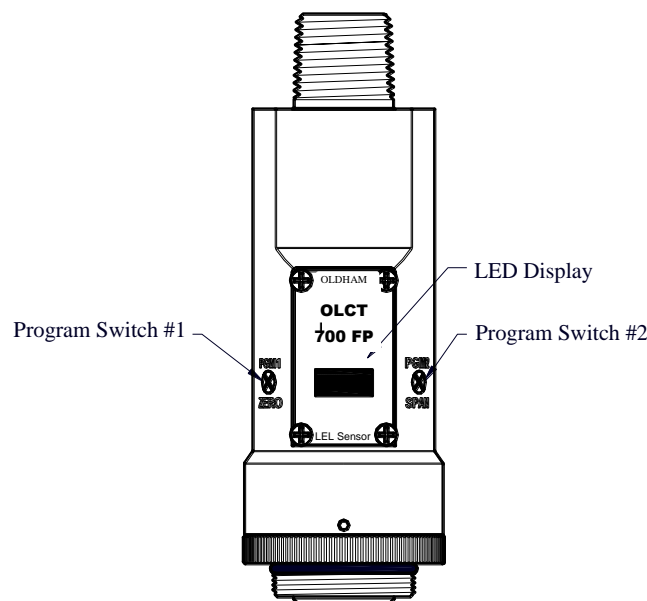

**Figure 13:** Magnetic Programming Switches

---

**NOTE:** While in the Program Mode, if there is no magnetic switch interaction after 4 consecutive menu scrolls, the detector will automatically revert to normal operating condition. While changing values inside menu items, **if there is no magnet activity after 3-4 seconds the detector will revert to the menu scroll** (*Exception to this is with “Signal Output Check” mode*).

---

## 3.2 Operator Interface

The operating interface is menu-driven via the two magnetic program switches (PGM1 and PGM2) located under the target marks of the detector housing. The menu list consists of three major items that include sub-menus as indicated below (refer to the complete Software Flow Chart in Figure 14: OLCT 700/710 FP Software Flowchart).

### Normal Operation

- Current Reading and Fault Status

### Calibration Mode

- AutoZero
- AutoSpan

### Program Mode

- View Sensor Status
  - Sensor Model Type
  - Current Software Version
  - Range of Detection
  - Serial ID address
  - AutoSpan Level
  - Days From Last AutoSpan
  - Remaining Sensor Life
  - Sensor Bridge Current
  - Sensor Bridge Voltage
  - Gas Factor
  - Cal Factor
  - 4-20mA Output
  - Input Voltage Supply
  - Operating Temperature
- Set AutoSpan Level
- Set Gas Factor
- Set Cal Factor
- Set Serial ID
- Set Bridge Voltage
- Signal Output Check
- Restore Default Settings

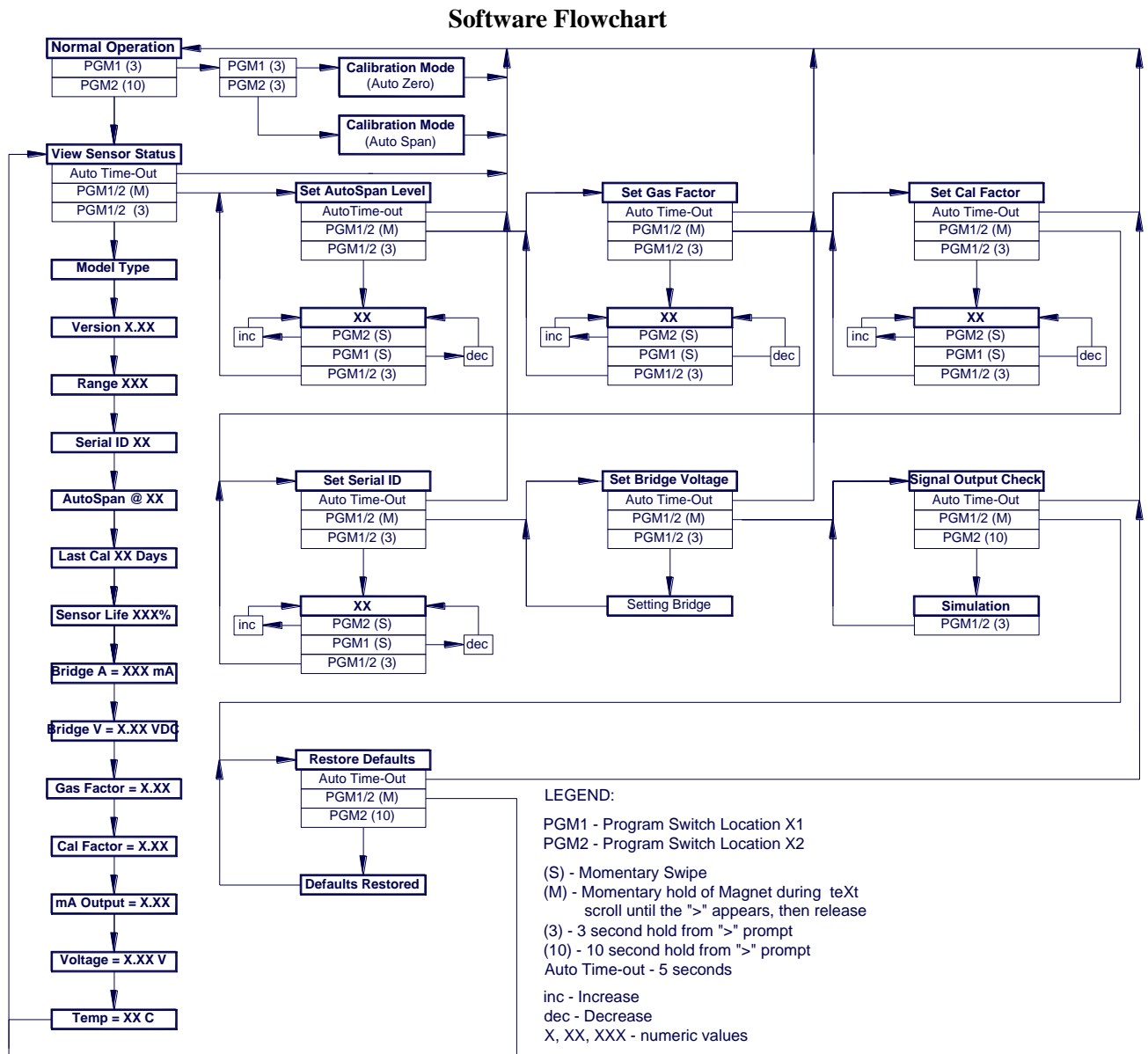

Figure 14: OLCT 700/710 FP Software Flowchart

### 3.3 Normal Operation

In normal operation, the OLCT 700/710 Display continuously shows the current detector reading, which will normally appear as “0”. Once every 60 seconds the LED display will flash the detector’s measurement units and gas type (i.e. % LEL). If the detector is actively experiencing any diagnostic faults, a “Fault Detected” message will flash on the display every 60 seconds. At any time, while the unit is in “Fault Detected” mode, PGM1 or PGM2 can be swiped to prompt the detector to display the list of the active faults.

In normal operation, the 4-20mA current output corresponds with the present gas concentration and full-scale range. The RS-485 Modbus™ serial output provides the current gas reading and fault status on a continuous basis when polled.



**Caution:** Off-scale readings may indicate a flammable concentration

### 3.4 Calibration Mode (AutoZero and AutoSpan)

#### 3.4.1 AutoZero

The AutoZero function is used to zero the detector. Local ambient air can be used to zero calibrate the detector as long as it can be confirmed that it contains no combustible gases. If this cannot be confirmed then a zero air cylinder should be used.

Material Requirements:

- PN DET-327-000000-000 MicroSafe™ Programming Magnet
- PN DET-613-120000-700 OLCT 700/710 Series Splash Guard with integral Cal Port and Calibration Wind Guard (PN DET-943-000000-000) -OR- PN DET-943-000006-132 Threaded Calibration Adapter
- PN 18108010 Zero Air cal gas, or use ambient air if no combustible gas is present

---

**NOTE 1:** The zero gas source should have a normal background concentration of 20.9% O<sub>2</sub>. Pure Nitrogen gas standards should not be used or errors may result.

---



---

**NOTE 2:** The Calibration Wind Guard must be used when the Splashguard Adapter with integral Cal Port is used. Failure to use the Calibration Wind Guard may result in an inaccurate AutoZero calibration.

---

- a) If the ambient air has is known to contain no combustible gas content, then it can be used to zero calibrate. If a zero gas cal cylinder is going to be used then attach the calibration adapter and set flow rate of 0.5l/min and let detector purge for 1-2 minutes before executing the AutoZero.
- b) From Normal Operation, enter Calibration Mode by holding the programming magnet over PGM1 for 3-4 seconds. Note, the “◀” prompt will show that the magnetic switch is activated during the 3 second hold period. The display will then scroll “PGM1=Zero ...PGM2=Span”. Hold the programming magnet over PGM1 for 3-4 seconds once the “◀” prompt appears to execute AutoZero (or allow to timeout in 10 seconds if AutoZero is not desired).

---

**NOTE:** Upon entering Calibration Mode, the 4-20mA signal drops to 2mA and is held at this level until the program returns to normal operation. Modbus™ Status Register bit 14 is also set to signify when the detector is in-calibration mode.

---

The OLCT 700/710 will display the following sequence of text messages as it proceeds through the AutoZero sequence: **Zero Cal. . .Setting Zero. . . Zero Saved**

- c) Remove the zero gas and calibration adapter, if applicable.

#### 3.4.2 AutoSpan

The AutoSpan function is used to span calibrate the detector. Span adjustment is recommended at 50% LEL. If a span gas containing the recommended concentration is not available, other concentrations may be used as long as they fall between 5% and 95% LEL (0-100% LEL range) or 2% and 50% LEL (0-50% LEL range). However, any alternate span gas concentration value must be programmed via the “Set AutoSpan Level” menu before proceeding with AutoSpan calibration (see Section 3.5.3).

Material Requirements:

- PN DET-327-000000-000 MicroSafe™ Programming Magnet
- PN DET-613-120000-700 OLCT 7000/710 Series Splash Guard with integral Cal Port and Calibration Wind Guard (P/N DET-943-000000-000) -OR- PN DET-943-000006-132 Threaded Calibration Adapter

- PN 18108011 Span Gas; 2.5% vol. Methane (50% LEL) in balance Air or other suitable span gas containing a certified level of % LEL concentration of common combustibile hydrocarbon gas.

---

**NOTE 1:** The span gas source must have a normal background concentration of 20.9% O<sub>2</sub>. Pure Nitrogen background mixtures are not acceptable! Significant span calibration inaccuracies will result.

---



---

**NOTE 2:** If the span gas is different from the measured target gas, use the appropriate Cal Factor as described in Section 3.5.4.

---



---

**NOTE 3:** If the target gas is other than methane, use the appropriate Gas Factor as described in Section 3.5.4.

---



---

**NOTE 4:** The Calibration Wind Guard must be used when the Splashguard Adapter with integral Cal Port is used. Failure to use the Calibration Wind Guard may result in an inaccurate AutoSpan calibration.

---

- Verify that the AutoSpan Level is equal to the calibration span gas concentration (refer to View Sensor Status in Section 3.5.2). If the AutoSpan Level is not equal to the calibration span gas concentration, adjust the AutoSpan Level as instructed in Section 3.5.3.
- From Normal Operation, enter Calibration Mode by holding the programming magnet over PGM1 for 3-4 seconds. Note, the “◀” prompt will show that the magnetic switch is activated during the 3-4 second hold period. The display will then scroll “PGM1=Zero...PGM2=Span”. Hold the programming magnet over PGM2 for 3-4 seconds once the “▶” prompt appears, until the display starts to scroll “Span Cal” to execute AutoSpan (or allow to timeout in 5 seconds if AutoSpan is not desired). The OLCT 700/710 will then scroll “Apply XX % LEL” (where XX is the AutoSpan Level).

---

**NOTE:** Upon entering Calibration Mode, the 4-20mA signal drops to 2mA and is held at this level until the program returns to normal operation. Modbus™ Status Register bit 14 is also set to signify when the detector is in-calibration mode.

---

- Apply the span calibration test gas at a flow rate of 0.5l/min. As the detector signal begins to increase, the display will switch to reporting a flashing “XX” reading as the detector shows the sensor’s “as found” response to the span gas presented. If it fails to meet the minimum in-range signal change criteria within 2½ minutes, the display will report “Range Fault” twice and the OLCT 700/710 will return to normal operation, aborting the AutoSpan sequence. The detector will continue to report a “Range Fault” and will not clear the fault until a successful AutoSpan is completed.

After about 1 minute the reading will auto-adjust to the programmed AutoSpan level. For about another 30 seconds the AutoSpan sequence checks the sensor for acceptable reading stability. If the sensor fails the stability check, the reading is re-adjusted back to the AutoSpan level and the cycle repeats until the stability check is passed. Up to three additional 30-second stability check periods are allowed before the unit reports a “Stability Fault” twice and the OLCT 700/710 will return to normal operation, aborting the AutoSpan sequence. The detector will continue to report a “Stability Fault” and will not clear the fault until a successful AutoSpan is completed.

If the sensor passes the stability check, the OLCT 700/710 reports a series of messages:

“AutoSpan Complete”  
 “Sensor Life XXX%”  
 “Remove Span Gas”



- d) Remove the span gas and calibration adapter. The OLCT 700/710 will report a live reading as it clears toward “0”. When the reading clears below the threshold of 5% LEL (100% LEL range), the detector will display “Span Complete” and will revert to normal operation. If the sensor fails to clear to less than the threshold within 5 minutes, a “Clearing Fault” will be reported twice and the OLCT 700/710 will return to normal operation, aborting the AutoSpan sequence. The detector will continue to report a “Clearing Fault” and will not clear the fault until a successful AutoSpan is completed.

---

**NOTE 1:** If the sensor fails the minimum signal change criteria, a “**Range Fault**” will be declared and a “Fault Detected” message will be displayed alternately with the detector’s current reading. The 4-20mA output will be taken to 0mA and the “Range Fault” fault bit will be set on the Modbus output.

---

---

**NOTE 2:** If the sensor fails the stability criteria, a “**Stability Fault**” will be declared and a “Fault Detected” message will be displayed alternately with the detector’s current reading. The 4-20mA output will be taken to 0mA and the “Stability Fault” fault bit will be set on the Modbus output.

---

---

**NOTE 3:** If the sensor fails the clearing time criteria, a “**Clearing Fault**” will be declared and a “Fault Detected” message will be displayed alternately with the detector’s current reading. The 4-20mA output will be taken to 0mA and the “Clearing Fault” fault bit will be set on the Modbus output.

---

## 3.5 Program Mode

Program Mode provides a View Sensor Status menu to check operational and configuration parameters. Program Mode also provides for adjustment of the AutoSpan Level, Bridge Voltage, Gas Factor, Cal Factor, and Serial ID. Additionally, it includes the Restore Factory Defaults and Signal Output Check diagnostic functions.

The Program Mode menu items appear in the order presented below:

- View Sensor Status
- Set AutoSpan Level
- Set Gas Factor
- Set Cal Factor
- Set Serial ID
- Set Bridge Voltage
- Signal Output Check
- Restore Default Settings

### 3.5.1 Navigating Program Mode

From Normal Operation, enter Program Mode by holding the magnet over PGM2 for 4 seconds (until the displays starts to scroll “View Sensor Status”). Note, the “◀” prompt will show that the magnetic switch is activated during the 4 second hold period. The OLCT 700/710 will enter Program Mode and the display will display the first menu item “View Sensor Status”. To advance to the next menu item, hold the magnet over PGM1 or PGM2 while the current menu item’s text is scrolling. At the conclusion of the text scroll the arrow prompt (“◀” for PGM2 or “▶” for PGM1) will appear, immediately remove the magnet. The OLCT 700/710 will advance to the next menu item. Repeat this process until the desired menu item is displayed. Note, PGM1 moves the menu items from right to left and PGM2 moves the menu items from left to right.



To enter a menu item, hold the magnet over PGM1 or PGM2 while the menu item is scrolling. At the conclusion of the text scroll the “◀” prompt (“◀” for PGM2 or “▶” for PGM1) will appear, continue to hold the magnet over PGM1 or PGM2 for an additional 3-4 seconds to enter the selected menu item. If there is no magnet activity while the menu item text is scrolling (typically 4 repeated text scrolls), the OLCT 700/710 will automatically revert to Normal Operation.

### 3.5.2 View Sensor Status

**View Sensor Status** displays all current configuration and operational parameters including: sensor type, software version number, detection range, AutoSpan level, days since last AutoSpan, estimated remaining sensor life, heater power, raw resistance, input voltage and detector ambient temperature.

From the **View Sensor Status** text scroll, hold the magnet over PGM1 or PGM2 until the “◀” prompt appears and continue to hold the magnet in place for an additional 3-4 seconds (until the display starts to scroll “Status Is”). The display will scroll the complete list of detector status parameters sequentially:

#### **Sensor Model Type**

The menu item appears as: “700 FP”

#### **Current Software Version**

The menu item appears as: “V X.XXZ”

#### **Range of Detection**

The menu item appears as: “Range XXX”

#### **Serial ID address**

The menu item appears as: “Serial ID XX”

#### **AutoSpan Level**

The menu item appears as: “Auto Span Level XX”

#### **Days From Last AutoSpan**

The menu items appears as: “Last Cal XX days”

#### **Remaining Sensor Life**

The menu item appears as: “Sensor Life 100%”

#### **Sensor Bridge Current**

The menu item appears as: “Bridge XXXmA

#### **Sensor Bridge Voltage**

The menu item appears as: “Bridge X.XXVDC

#### **Gas Factor**

The menu item appears as: “Gas Factor X.X”

#### **Cal Factor**

The menu item appears as: “Cal Factor X.X”

#### **4-20mA Output**

The menu item appears as: “mA Output X.XXmA”

#### **Input Voltage Supply**

The menu item appears as: “Voltage XX.XVDC”

#### **Operating Temperature**

The menu item appears as: “Temp= XX C”

When the status list sequence is complete, the OLCT 700/710 will revert to the “View Sensor Status” text scroll. The user can either: 1) review list again by executing another 3-4 second hold, 2) move to another menu item by executing a momentary hold over PGM1 or PGM2, or 3) return to Normal Operation via automatic timeout of about 15 seconds (the display will scroll “View Sensor Status” 4 times and then return to Normal Operation).

### 3.5.3 Set AutoSpan Level

**Set AutoSpan Level** is used to set the span gas concentration level that is being used to calibrate the detector. This level is adjustable from 5% to 95% LEL. The current setting can be viewed in View Program Status.

From the **Set AutoSpan Level** text scroll, hold the magnet over PGM1 or PGM2 until the “◀” prompt appears and continue to hold the magnet in place for an additional 3-4 seconds (until the display starts to scroll “Set Level”). The display will switch to “XX” (where XX is the current gas level). Swipe the magnet momentarily over PGM2 to increase or PGM1 to decrease the AutoSpan Level until the correct level is displayed. When the correct level is achieved, hold the magnet over PGM1 or PGM2 for 3-4 seconds to accept the new value. The display will scroll “Level Saved”, and revert to “Set AutoSpan Level” text scroll.

Move to another menu item by executing a momentary hold, or return to Normal Operation via automatic timeout of about 15 seconds (the display will scroll “Set AutoSpan Level” 4 times and then return to Normal Operation).

### 3.5.4 Set Gas Factor

Because of the catalytic bead sensor’s almost universal response to combustible gases, the OLCT 700/710 FP detector can be configured to specifically detect any of the combustible gases listed in Table 2. This gas is referred to as the “target gas”. In addition, the detector can also be configured so that it can be calibrated with any of the listed gases regardless of which target gas is selected. This gas is referred to as the “cal gas”. These two features, **Set Gas Factor** and **Set Cal Factor**, allow a significant degree of flexibility in the detection and span calibration process.

---

**NOTE:** The default value for gas factor is 1.0. This would be used when methane is the target gas. Values other than 1.0 would be used when the target gas is not methane.

---

**Set Gas Factor** is used to make the appropriate signal sensitivity adjustment when the target gas is a gas other than methane. This is necessary because the catalytic bead sensor has different signal strengths for each combustible gas and all reading calculations are made based on a reference to methane. The gas factor value is adjustable from 0.2 to 5.0. It represents the translation between the target gas and methane gas, where methane has a normalized gas factor = 1.0. For example, the gas factor for butane is 1.71, because the signal strength of butane is 1.71 times lower than methane. The current setting can be viewed in View Program Status – Gas Factor.

The following table shows the Gas Factors of most combustible gases that can be measured. Find the target gas and enter the corresponding value as the Gas Factor. For example, if butane were the target gas, the correct gas factor would be 1.71. If there is a mixture of target gases, use a weighted approach to determine the correct Gas Factor. For example, if the target gas was 50% butane and 50% methane, the correct gas factor would be calculated and entered as  $(0.5 \times 1.71) + (0.5 \times 1.0) = 1.35$ .

**Table 2: Gas/Cal Factors**

Gas	Factor	Gas	Factor	Gas	Factor
Acetaldehyde	1.66	Decane	3.05	Dimethyl Ether	1.60
Acetic Acid	1.84	Diethylamine	2.05	Methylethyl Ether	2.27
Acetic Anhydride	2.17	Dimethylamine	1.73	Methylethyl Ketone	2.42
Acetone	1.93	2,3-Dimethylpentane	2.51	Methyl Formate	1.49
Acetylene	1.76	2,2-Dimethylpropane	2.52	Methyl Mercaptan	1.64
Alkyl Alcohol	1.96	Dimethyl Sulphide	2.30	Methyl propionate	1.95
Ammonia	0.79	1,4-Dioxane	2.24	Methyl n-propyl Ketone	2.46
n-Amyl Alcohol	3.06	Ethane	1.47	Naphtha	3.03
Aniline	2.54	Ethyl Acetate	1.95	Naphthalene	2.94
Benzene	2.45	Ethyl Alcohol	1.37	Nitromethane	1.72
Biphenyl	4.00	Ethylamine	1.90	n-Nonane	3.18
1,3-Butadiene	1.79	Ethyl Benzene	2.80	n-Octane	2.67
Butane	1.71	Ethylcyclopentane	2.52	n-Pentane	2.18
iso-Butane	1.93	Ethylene	1.41	iso-Pentane	2.15
Butene-1	2.20	Ethylene Oxide	1.93	Propane	1.81
cis-Butene-2	2.06	Diethyl Ether	2.16	n-Propyl Alcohol	2.12
trans-Butene-2	1.97	Ethyl Formate	2.26	n-Propylamine	2.07
n-Butyl Alcohol	2.91	Ethyl Mercaptan	1.78	Propylene	1.95
iso-Butyl Alcohol	1.89	n-Heptane	2.59	Propylene Oxide	2.18
tert-Butyl-Alcohol	1.34	n-Hexane	2.71	iso-Propyl Ether	2.29
n-Butyl Benzene	3.18	Hydrazine	2.22	Propyne	2.40
iso-Butyl Benzene	3.12	Hydrogen Cyanide	2.09	Toluene	2.47
n-Butyric Acid	2.63	Hydrogen	1.30	Triethylamine	2.51
Carbon Disulphide	5.65	Hydrogen Sulphide	2.54	Trimethylamine	2.06
Carbon Monoxide	1.32	Methane	1.00	Vinyl Chloride	2.32
Carbon Oxysulphide	1.07	Methyl Acetate	2.01	Vinyl Ethyl Ether	2.38
Cyanogen	1.12	Methyl Alcohol	1.16	o-Xylene	2.79
Cyclohexane	2.43	Methylamine	1.29	m-Xylene	2.55
Cyclopropane	1.60	Methylcyclohexane	2.26	p-Xylene	2.55

From the **Set Gas Factor** text scroll, hold the magnet over PGM1 or PGM2 until the “◀” prompt appears and continue to hold the magnet in place for an additional 3-4 seconds (until the display starts to scroll “Set Factor”). The display will then switch to “X.XX” (where X.XX is the current gas factor). Swipe the magnet momentarily over PGM2 to increase or PGM1 to decrease the gas factor level until the correct value is displayed. Hold the magnet over PGM1 or PGM2 for 3 seconds to accept the new value. The display will scroll “Factor Saved”, and revert to “Set Gas Factor” text scroll.

Move to another menu item by executing a momentary hold, or, return to Normal Operation via automatic timeout of about 15 seconds (the display will scroll “Set Gas Factor” 4 times and then return to Normal Operation).

### 3.5.5 Set Cal Factor

Because of the catalytic bead sensor’s almost universal response to combustible gases, the OLC7 700/710 FP detector can be span calibrated with any of the combustible gases listed in Table 2 above. This specific gas is referred to as the “cal gas”.

---

**NOTE:** The default value for cal factor is 1.0. This would be used when methane is the cal gas. Values other than 1.0 would be used when the span cal gas is not methane.

---

**Set Cal Factor** is used to make the appropriate signal sensitivity adjustment when the cal gas is a gas other than methane. This is necessary because the catalytic bead sensor has different signal strengths for each combustible gas and all reading calculations are made based on a reference to methane. The cal factor value is adjustable from 0.2 to 5.0. It represents the translation between the cal gas and methane gas, where methane has a normalized cal factor = 1.0.

For example, the cal factor for butane is 1.71 because the signal strength of butane is 1.71 times lower than methane. The current setting can be viewed in View Program Status.

Table 2 shows the Cal Factors of most combustible gases that will be used as span calibration sources. Find the gas of interest and enter that value the Cal Factor. For example, if propane were used as the cal gas, the correct cal factor would be 1.81.

From the **Set Gas Factor** text scroll, hold the magnet over PGM1 or PGM2 until the “◀” prompt appears and continue to hold the magnet in place for an additional 3-4 seconds (until the display starts to scroll “Set Factor”). The display will then switch to “X.XX” (where X.XX is the current cal factor). Swipe the magnet momentarily over PGM2 to increase or PGM1 to decrease the gas factor level until the correct value is displayed. Hold the magnet over PGM1 or PGM2 for 3-4 seconds to accept the new value. The display will scroll “Factor Saved”, and revert to “Set Cal Factor” text scroll.

Move to another menu item by executing a momentary hold, or, return to Normal Operation via automatic timeout of about 15 seconds (the display will scroll “Set Cal Factor” 4 times and then return to Normal Operation).

### 3.5.6 Set Serial ID

Oldham OLCT 700/710 FP detectors can be polled serially via RS-485 Modbus™ RTU. Refer to Section 4.0 for details on using the Modbus™ output feature.

**Set Serial ID** is used to set the Modbus™ serial ID address. It is adjustable from 01 to 256 in hexadecimal format (01-FF hex). The current serial ID can be viewed in View Sensor Status using the instruction given in Section 3.5.2 View Sensor Status.

From the “**Set Serial ID**” text scroll, hold the programming magnet over PGM1 or PGM2 until the “◀” prompt appears and continue to hold the magnet in place for an additional 3-4 seconds (until the display starts to scroll “Set ID”). The display will then switch to “XX” (where XX is the current ID address). Swipe the magnet momentarily over PGM2 to increase or PGM1 to decrease the hexadecimal number until the desired ID is displayed. Hold the magnet over PGM1 or PGM2 for 3-4 seconds to accept the new value. The display will scroll “ID Saved”, and revert to “Set Serial ID” text scroll.

Move to another menu item by executing a momentary hold, or, return to Normal Operation via automatic timeout of about 15 seconds (the display will scroll “Set Serial ID” 5 times and then return to Normal Operation).

### 3.5.7 Set Bridge Voltage

Each plug-in combustible gas sensor requires a one-time setting for optimal bridge voltage. This is set automatically during the “Set Bridge Voltage” sequence. The “Set Bridge Voltage” sequence determines the required bridge voltage such that every plug-in sensor operates at exactly 200mA current. This technique provides for tremendous uniformity in sensor-to-sensor operational performance, and it is notably better than sensors that are operated on a common fixed bridge voltage platform. The range of bridge voltages required for sensors is generally between 2.5 – 2.9VDC.

---

**NOTE:** The “Set Bridge Voltage” function is executed during factory calibration of every OLCT 700/710 FP detector. In the field, this menu item is only needed when a replacement plug-in sensor is being installed, or when mating a new ITM with an existing plug-in sensor.

---

From the **Set Bridge Voltage** text scroll, hold the magnet over PGM1 or PGM2 until the “◀” prompt appears and continue to hold the magnet in place for an additional 7-8 seconds (until the display starts to scroll “Setting Bridge”). The OLCT 700/710 will then display “WAIT”. During the 1-minute sequence, the detector will display the three-digit number that corresponds to the bridge current as it is being adjusted.

At conclusion, display will scroll “Set Bridge Voltage”. The new bridge voltage can be viewed in the “View Sensor Status” menu.

Move to another menu item by executing a momentary hold, or, return to Normal Operation via automatic timeout of about 15 seconds (the display will scroll “Set Bridge Voltage” 4 times and then return to Normal Operation).

### 3.5.8 Signal Output Check

**Signal Output Check** provides a simulated 4-20mA output and RS-485 Modbus™ output. This simulation allows the user to conveniently perform a functional system check of their entire safety system. This signal output simulation also aids the user in performing troubleshooting of signal wiring problems.

From the “Signal Output Check” text scroll, hold the magnet over PGM1 or PGM2 until the “◀” prompt appears and then hold continuously for an additional 10 seconds. Once initiated, the display will scroll “Simulation Active” until the function is stopped. During simulation mode, the 4-20mA value will be increased from 4.0mA to 20.0mA (in 1% of range increments at about a 1 second update rate) and then decreased from 20.0mA to 4.0mA. The same simulation sequence is applied to the Modbus™ output gas reading.

---

**NOTE:** Signal Output Check stays active indefinitely until the user stops the function. There is no automatic timeout for this feature.

---

To end simulation mode, hold magnet over PGM1 or PGM2 for 3 seconds. The display will either move to the prior menu item or move to the next menu item respectively.

Move to another menu item by executing a momentary hold, or, return to Normal Operation via automatic timeout of about 15 seconds.

### 3.5.9 Restore Factory Defaults

**Restore Factory Defaults** is used to clear current user configuration and calibration data from memory and revert to factory default values. This may be required if the settings have been configured improperly and a known reference point needs to be re-established to correct the problem.

---

**NOTE:** “Restoring Factory Defaults” should only be used when absolutely necessary. All previously existing configurational inputs will have to be re-entered if this function is executed. A full 10-second magnet hold on PGM 2 is required to execute this function.

---

From the “Restore Defaults” text scroll, hold the programming magnet over PGM2 until the “◀” prompt appears and continue to hold 10 seconds. The display will scroll “Restoring Defaults”, and then will revert to the “Restore Defaults” text scroll.

Move to another menu item by executing a momentary hold, or, return to Normal Operation via automatic timeout of about 15 seconds (the display will scroll “Restore Defaults” 4 times and then return to Normal Operation).

Following the execution of “**Restore Defaults**”, the OLCT 700/710 FP will revert to its factory default settings. The default settings are:

- Serial ID = 01. The Serial ID must be set appropriately by the operator (Section 3.5.6).

---

**NOTE:** The following must be performed in order before the detector can be placed in operation.

---

- AutoSpan Level = 50 %LEL. AutoSpan level must be set appropriately by the operator (Section 3.5.3).

- Gas Factor = 1.0. The Gas Factor must be set appropriately by the operator (Section 3.5.4).
- Cal Factor = 1.0. The Cal Factor must be set appropriately by the operator (Section 3.5.5).
- AutoZero: AutoZero Settings are lost and user must perform new AutoZero (Section 3.4).
- AutoSpan: AutoSpan Settings are lost and user must perform new AutoSpan (Section 3.4).

## 3.6 Program Features

Oldham OLCT 700/710 FP gas detectors incorporate a comprehensive set of diagnostic features to achieve Fail-Safe Operation. These Operational features and Failsafe Diagnostic features are detailed below.

### 3.6.1 Operational Features

#### Over-Range

When gas greater than the full-scale range is detected, the OLCT 700/710 display will continuously flash the full-scale reading. This designates an over-range condition. The 4-20mA signal will report a 22mA output during this time.

#### In-Calibration Status

When the detector is engaged in AutoZero or AutoSpan calibration, the 4-20mA output signal is taken to 2.0mA and the in-calibration Modbus™ Status Register bit 14 is set. This alerts the user that the OLCT 700/710 is not in an active measurement mode. This feature also allows the user to log the AutoZero and AutoSpan events via their master control system.

#### Sensor Life

Sensor Life is calculated after each AutoSpan calibration and is reported as an indicator of remaining service life. It is reported in the “View Sensor Status” menu and as a RS-485 Modbus register bit. Sensor Life is reported on a scale of 0-100%. When Sensor Life falls below 25%, the sensor cell should be replaced within a reasonable maintenance schedule.

#### Last AutoSpan Date

This reports the number of days that have elapsed since the last successful AutoSpan. This is reported in the View Sensor Status menu.

### 3.6.2 Fault Diagnostic/Failsafe Features

#### Fail-Safe/Fault Supervision

OLCT 700/710 FP detectors are designed for Fail-Safe operation. If any of the diagnostic faults listed below are active, the display will alternately scroll the message “Fault Detected” during normal operation. At any time while the “Fault Detected” message is scrolling, hold the programming magnet over PGM2 for 1 second to display the active fault(s). All active faults will then be reported sequentially.

Most fault conditions result in failed operation of the detector and in those cases the 4-20mA signal is dropped to the universal fault level of 0mA. These include the AutoZero and AutoSpan Calibration faults, Bridge Fault, Sensor Fault, Processor Fault, Memory Fault, Loop Fault, and Input Voltage Fault. The 0mA fault level is not employed for a Temperature Fault and AutoSpan Reminder Fault. For all diagnostic faults, the associated RS-485 Modbus™ fault register will be flagged to alert the user digitally.

---

**NOTE:** Refer to the Troubleshooting Guide section 0 for guidance on fault conditions.

---

#### Zero Fault

If the detector drifts below –10% LEL, the “Zero Fault” will be declared. A “Zero Fault” will cause a “Fault Detected” message to scroll once a minute on the display and drop the 4-20mA output to 0mA. The Modbus™ fault register bit for Zero Fault will be set and will not clear until the fault condition has been cleared. The detector should be considered “Out-of-Service” until a successful AutoZero calibration is performed.



**Range Fault – AutoSpan**

If the detector fails the minimum signal (Section 3.4.2) change criteria during AutoSpan sequence, the “Range Fault” will be declared. A “Range Fault” will cause a “Fault Detected” message to scroll once a minute on the display and drop the 4-20mA output to 0mA. The Modbus™ fault register bit for Range Fault will be set and will not clear until the fault condition has been cleared. The detector should be considered “Out-of-Service” until a successful AutoSpan calibration is performed.

**Stability Fault - AutoSpan**

If the detector fails the signal stability criteria (Section 3.4.2) during AutoSpan sequence, the “Stability Fault” will be declared. A “Stability Fault” will cause a “Fault Detected” message to scroll once a minute on the display and drop the mA output to 0mA. The Modbus™ fault register bit for Stability Fault will be set and will not clear until the fault condition has been cleared. The detector should be considered as “Out-of-Service” until a successful AutoSpan calibration is performed.

**Clearing Fault - AutoSpan**

If the detector fails the clearing criteria (Section 3.4.2) during AutoSpan sequence, the “Clearing Fault” will be declared. A “Clearing Fault” will cause a “Fault Detected” message to scroll once a minute on the display and drop the milliamp output to 0mA. The Modbus™ fault register bit for Clearing Fault will be set and will not clear until the fault condition has been cleared. The detector should be considered as “Out-of-Service” until a successful AutoSpan calibration is performed.

**Sensor Fault**

If either the active or reference catalytic bead should fail and become electrically open or the sensor was missing, a “Sensor Fault” will be declared. A “Sensor Fault” will cause a “Fault Detected” message to scroll once a minute on the display. The Modbus™ fault register bit for Sensor Fault will be set and will not clear until the fault condition has been cleared. If a Sensor Fault occurs, the 4-20mA signal will be set at 0mA until the fault condition is resolved.

**Processor Fault**

If the detector has any unrecoverable run-time errors, a “Processor Fault” is declared. A “Processor Fault” will cause a “Fault Detected” message to scroll once a minute on the display. The Modbus™ fault register bit for Processor Fault will be set and will not clear until the fault condition has been cleared. If a Processor Fault occurs, the 4-20mA signal will be set at 0mA until the fault condition is resolved.

**Memory Fault**

If the detector has a failure in saving new data to memory, a “Memory Fault” is declared. A “Memory Fault” will cause the “Fault Detected” message to scroll once a minute on the display. The Modbus™ fault register bit for Memory Fault will be set and will not clear until the fault condition has been cleared. If a Memory Fault occurs, the 4-20mA signal will be set at 0mA until the fault condition is resolved.

**4-20mA Loop Fault**

If the detector detects a condition where the 4-20mA output loop is not functional (high loop resistance or failed circuit function) a “4-20mA Fault” is declared. A “4-20mA Fault” will cause the “Fault Detected” message to scroll once a minute on the display. The Modbus™ fault register bit for Loop Fault will be set and will not clear until the fault condition has been cleared. If a Loop Fault occurs, the 4-20mA signal will be set at 0mA until the fault condition is resolved.

---

**NOTE: If the 4-20mA output is not being used, the Green wire from the ITM *must* be connected to the Black wire at the (-) J1 terminal (see Figure 11: Detector Wire Connections).**

---

**Input Voltage Fault**

If the detector is currently receiving an input voltage that is outside of the 11.5-28VDC range, an “Input Voltage Fault” is declared. An “Input Voltage Fault” will cause the “Fault Detected” message to scroll once a minute on the display. The fault register bit for Input Voltage Fault will be set and will not clear until the fault condition has been cleared. If an Input Voltage Fault occurs, the 4-20mA signal will be set at 0mA until the fault condition is resolved.





### **Temperature Fault**

If the detector is currently reporting an ambient temperature that is outside of the  $-40\text{C}$  to  $+75\text{C}$  range a “Temperature Fault” is declared. A “Temperature Fault” will cause the “Fault Detected” message to scroll once a minute on the display. The Modbus™ fault register bit for Temperature Fault will be set and will not clear until the fault condition has been cleared. If a Temperature Fault occurs, the 4-20mA signal remains operational.

### **AutoSpan Reminder Fault**

If 180 days has elapsed since the last successful AutoSpan, an AutoSpan Fault will be generated. An “AutoSpan Fault” will cause the “Fault Detected” message to scroll once a minute on the display. The Modbus™ fault register bit for AutoSpan Reminder Fault will be set and will not clear until the fault condition has been cleared. If an AutoSpan Reminder Fault occurs, the 4-20mA signal remains operational.

Refer to the Troubleshooting Guide, Section 0, for guidance on fault conditions. If you cannot fix the fault condition, email our Technical Service team at [support@oldhamgas.com](mailto:support@oldhamgas.com) or call +33 (0)3 21 60 80 86.

## 4. RS-485 Modbus™ Protocol

OLCT 700/710 detectors feature Modbus™ compatible communications protocol and are addressable via the program mode. Communication is two wire, half duplex 485, 9600 baud, 8 data bits, 1 stop bit, no parity, with the detector set up as a slave device. A master controller up to 1200 meters (4000 feet) away can theoretically poll up to 256 different detectors. This number may not be realistic in harsh environments where noise and/or wiring conditions would make it impractical to place so many devices on the same pair of wires. If a multi-point system is being utilized, each detector should be set for a different address. Typical address settings are: 01, 02, 03, 04, 05, 06, 07, 08, 09, 0A, 0B, 0C, 0D, 0E, 0F, 10, 11, etc.

Detector RS-485 ID numbers are factory default to 01. These can be changed in the field via the Operator Interface described in section 3.5.6, Set Serial ID.

The following section explains the details of the Modbus™ protocol that the OLCT 700/710 detector supports.

Code 03 - Read Holding Registers is the only code supported by the transmitter. Each transmitter contains 6 holding registers which reflect its current status.

**Table 3: Modbus™ Registers**

FC	REG	Content Description	R/W	Content Definition		
				Value	Meaning	Range
03	40000	Device Type	R	8	OLCT 700/710 Detector	
03 06	40001 40001	Read Detectable Range <sup>1,2</sup> Write Detectable Range	R/W	100 10000	For 0-100 For 0-10000 <sup>2</sup>	FP – Read only TP – 20, 50, 100, 200 IR – 0 to 10000
03	40002	Read Concentration <sup>3,2</sup>	R	1000	Bound by range. If > range, this value is in fault.	
03 06	40003 40003	Read AutoSpan Level <sup>4,2</sup> Write AutoSpan Level	R/W	50	Span gas at 50	FP – 5% to 95% of Range (40001) TP – 2% to 50% of Range (40001) IR – 5% to 95% of Range (40001)
03	40004	Read Sensor Life	R	85	For 85% sensor life	
03	40005	Read Fault Status Bits <sup>5</sup>	R	0x0001 0x0002 0x0004 0x0008 0x0010 0x0020 0x0040 0x0080 0x0100 0x0200 0x0400 0x0800 0x1000 0x2000 0x4000 0x8000	Global Fault Auto Span Fault Temperature Fault 4-20mA Fault Input Voltage Fault Memory Fault Processor Fault Clearing Fault Stability Fault Range Fault Sensor Fault Zero Fault Sensor Fault 2 <reserved> In Calibration Communication Error	
03	40006	Read Model #	R	1, 2, 3, 4, 5	DM, FP, IR, TP, PID respectively	
03	40007	Read Days Since Cal	R	29	29days	
03	40008	4-20 Current Output mA x100	R	400	4.00mA	<b>Range</b>
03	40009	Read Input Voltage V x100	R	2400	24.00V	
03	40010	Read Temperature	R	28	28 °C	
03/ 06	40011	Special #1	R/W		Function dependent on value of 40006 (See Special Register Table 4)	
03/ 06	40012	Special #2	R/W		Function dependent on value of 40006 (See Special Register Table 4)	
03	40013	Special #3	R		Function dependent on value of 40006 (See Special Register Table 4)	

FC	REG	Content Description	R/W	Content Definition		
				Value	Meaning	Range
03/06	40014	Special #4	R/W		Function dependant on value of 40006 (See Special Register Table 4)	
03  06	40015	Calibration Status	R	0x0000 0x0001 0x0002 0x0003 0x0004	Idle Zero Calibration Started Span Calibration Started Span Set Span Calibration Unsuccessful	
	40015	Calibration Enable	W	0x0001 0x0002 0x0008 0x0009 0x000A 0x000B	Set Zero Set Span Signal simulation mode Set OLCT 700/710 FP Bridge Voltage Set OLCT 700/710 TP Heater Power Set OLCT 700/710 IR Gain	
03	40016	Read Text 1, first char in L	R		Two Char of Gas/Units String <sup>6</sup>	
03	40017	Read Text 2	R		Two Char of Gas/Units String <sup>6</sup>	
03	40018	Read Text 3	R		Two Char of Gas/Units String <sup>6</sup>	
03	40019	Read Text 4	R		Two Char of Gas/Units String <sup>6</sup>	
03	40020	Read Text 5, last char in H	R		Two Char of Gas/Units String <sup>6</sup>	
03	40021	Text null terminator in L	R		Two Char of Gas/Units String <sup>6</sup>	

- <sup>1</sup> Integer ranges from 1 all the way to 10,000.
- <sup>2</sup> Units are determined by “units” field in the “notation” string
- <sup>3</sup> Gas Reading times one (x 1) with units in notation string for “Low Range” = 0. Gas Reading times one (x 10) with units in notation string for “Low Range” = 1. Gas Reading times one (x 100) with units in notation string for “Low Range” = 2.
- <sup>4</sup> Span Gas must be less than or equal to Detectable Range and is usually about 1/2 of it.
- <sup>5</sup> Fault status bits self-reset when fault clears
- <sup>6</sup> Text in ASCII, in order L byte, H byte, L byte... See field descriptions of notation string.

Gas/Units String

Character #	1	2	3	4	5	6	7	8	9	10	11
Description	Units			0x20	Gas Type						0x00

Units – This field is ‘PPM’, ‘PPB’, or ‘\_ \_ %’ (where ‘\_’ is a space, 0x20).  
 0x20 – The units filed is terminated with an ASCII space (0x20)

Gas Type – This field contains the gas type of the cell. Any ASCII string is permissible  
 0x00 – The notation string is terminated with an ASCII null character

**Table 4: Modbus™ Special Registers**

REG	700/710 FP (40006 = 2)	700/710 IR (40006 = 3)	700/710 TP (40006 = 4) <sup>1</sup>
40011	Gas Factor (R/W) <b>Range = 79 to 565</b>	Gas Factor (R/W) <b>Range = 20 to 565</b>	Heater Power (mW) (R/W)
40012	Cal Factor (R/W) <b>Range = 79 to 565</b>	Active Counts	Heater Voltage (mV)
40013	Bridge Current (mA)	Reference Counts	Sensor Resistance (x100 Ω)
40014	Bridge Voltage (mV) <b>(Read only)</b>	Range Divisor 1,10,100, or 1000	Heater Current (mA)

<sup>1</sup> Only possible ranges are 20, 50, 100, 200. Modbus register 40001 will contain either 20, 50, 100, or 200, range divisor is not necessary.

## 5. Service and Maintenance

### 5.1 Calibration Frequency

Gas detectors are safety devices. OLDHAM recommends the regular testing of fixed gas detection installations. This type of test consists of applying calibration gas at a sufficient concentration to trigger the pre-set alarms. It is to be understood that this test is in no way a replacement for a detector calibration. The bump tests frequency depends on the application. Upon initial installation and commissioning, close frequency tests should be performed, weekly to monthly. Test results should be recorded and reviewed to determine a suitable calibration interval; however, it must not exceed one year. The general manager should put safety procedures in place on-site. OLDHAM cannot be held responsible for their enforcement.

### 5.2 Visual Inspection

The Detector should be inspected annually. Inspect for signs of corrosion, pitting, and water damage. During visual inspection, the Splash Guard should be inspected to insure that it is not blocked. Examine the porous 316SS flame arrestor within the detector's bottom housing for signs of physical blockage or severe corrosion. Also, inspect inside the Junction Box for signs of water accumulation or Terminal Block corrosion.

### 5.3 Condensation Prevention Packet

A moisture condensation packet should be installed in every explosion proof Junction Box. The moisture condensation prevention packet will prevent the internal volume of the J-Box from condensing and accumulating moisture due to day-night humidity changes. This packet should be replaced annually. Oldham's PN is DET-960-202200-000.

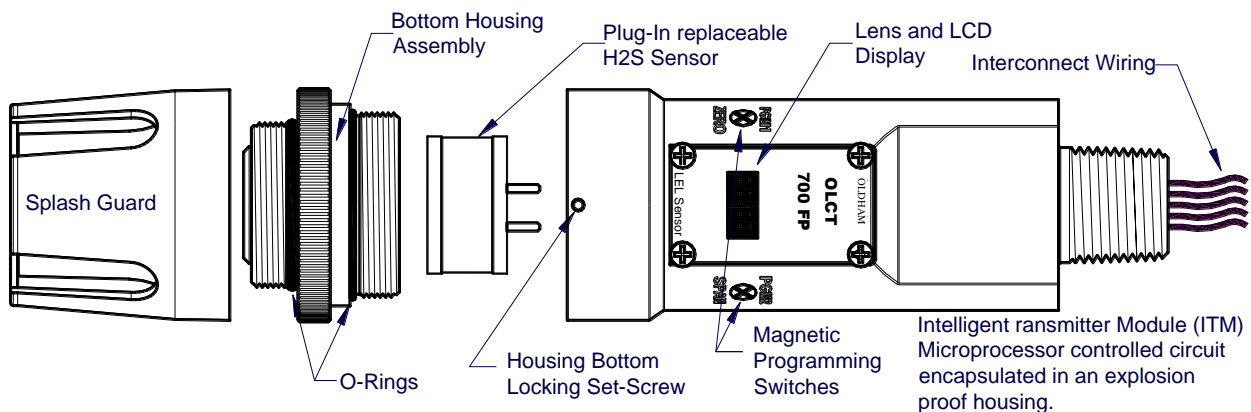

Figure 15: Sensor Assembly

### 5.4 Replacement of Plug-in Combustible Gas Sensor

a) Remove power to OLCT 700/710 FP detector by lifting the + 24VDC wire in J-Box.

**NOTE:** It is necessary to remove power while changing the plug-in combustible gas sensor in order to maintain area classification.

b) Use a M1.5 Allen wrench to release the locking setscrew that locks the ITM and bottom housing together (One turn will suffice - Do not remove setscrew completely).

- c) Remove splashguard. Unthread and remove the Bottom Housing from the ITM.
- d) Gently pull the plug-in combustible gas sensor out of the ITM. Orient the new plug-in sensor so that it matches with the female connector pins. It may be necessary to look from below to assure alignment is correct. When properly aligned, press the sensor in firmly to make the proper connection.
- e) Thread the Bottom Housing onto the ITM to a snug fit and tighten the locking setscrew using the M1.5 Allen wrench. Reinstall the splashguard.
- e) With the new plug-in sensor physically installed, two menu functions are required to be performed:
  - The Set Bridge Voltage function must be performed to match the new sensor with the ITM (Section 3.5.7)
  - Perform a successful AutoZero and AutoSpan to match the new sensor with the ITM (Section 3.4).

## 6. Troubleshooting Guide

Refer to the list of Failsafe Diagnostic features listed in Section 3.6 for additional reference in troubleshooting activities. Listed below are some typical trouble conditions and their probable cause and resolution path.

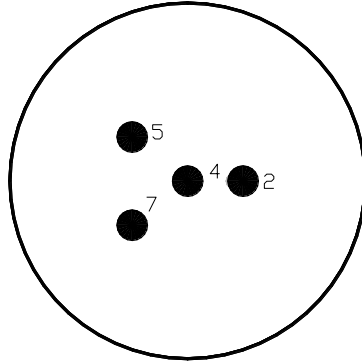

**Figure 16:** Plug-in Sensor (Bottom View)

### Open Sensor Fault

Probable Cause: Plug-in sensor has failed.

Remove plug-in sensor and verify resistance between PIN 4 and PIN 5 and PIN 4 and PIN 2 using an ohmmeter. At room temperature, the normal reading range should be 2.5-3.5 ohms for both catalytic beads. Replace plug-in sensor if either measurement is open circuit or significantly out-of range.

### Zero Fault

Probable Causes: Plug-in sensor has drifted.

- Perform AutoZero calculation per Section 3.4
- Replace the plug-in sensor

### AutoSpan Calibration Faults – (Range, Stability and Clearing)

To clear any AutoSpan Calibration fault, the AutoSpan process must be completed successfully.

### Range Fault

Probable Causes: Failed Sensor, Cal Gas not applied or not applied at appropriate time, or problems w/ cal gas and delivery.

- Check Bridge Voltage (should be 2.7 +/- 0.2VDC)
- Check validity of span gas and flow rate (check MFG date on cal cylinder)
- If using Splashguard with Integral Cal Port, must use Calibration Wind Guard or air movement can compromise span gas delivery
- Make sure correct Cal Factor is set
- Check for obstructions through stainless steel sinter element (including being wet)
- Replace the plug-in sensor

### Stability Fault

Probable Causes: Failed Sensor, empty or close to empty Cal Gas Cylinder, or problems w/ cal gas and delivery.

- Check Bridge Voltage (should be 2.7 +/- 0.2VDC)
- Check validity of span gas and flow rate (check MFG date on cal cylinder)

- If using Splashguard with Integral Cal Port, must use Calibration Wind Guard or air movement can compromise span gas delivery
- Make sure correct Cal Factor is set
- Check for obstructions through stainless steel sinter element (including being wet)
- Replace the plug-in sensor

### **Clearing Fault**

Probable Causes: Failed Sensor, Cal Gas not removed at appropriate time, problems w/ cal gas and delivery, or Background combustible gases preventing clearing.

- Confirm that no combustible gasses are present in background
- Check Bridge Voltage (should be 2.7 +/- 0.2VDC)
- Check validity of span gas and flow rate (check MFG date on cal cylinder)
- Make sure correct Cal Factor and Gas Factor is set
- Check for obstructions through stainless steel sinter element (including being wet)
- Replace the plug-in sensor

### **Poor Calibration Repeatability**

Probable Causes: Failed Sensor, use of wrong Cal Gas, problems w/ cal gas and delivery, or Poison or Inhibitor Gases.

- Check for adequate Sensor Life
- Check Bridge Voltage (should be 2.7 +/- 0.2VDC)
- Check validity of span gas and flow rate (check MFG date on cal cylinder)
- Check for obstructions through stainless steel sinter element (including being wet)
- Evaluate area for presence of poisoning or inhibiting gases as listed in Section 2.4
- Increase calibration frequency
- Replace plug-in sensor
- If problem persists, note the sensor's serial # and contact Oldham Technical Support at [support@oldhamgas.com](mailto:support@oldhamgas.com)

### **Unstable Output/ Sudden spiking**

Possible Causes: Unstable power supply, inadequate grounding, or inadequate RFI protection.

- Verify Power source is stable
- Verify field wiring is properly shielded and grounded
- If problem persists, contact Oldham Technical Support at [support@oldhamgas.com](mailto:support@oldhamgas.com)

### **Nuisance Alarms**

- Check conduit for accumulated water and abnormal corrosion on terminal blocks
- Check terminal blocks are tight
- Add or replace Oldham's Condensation Prevention Packet P/N DET-960-202200-000
- Investigate the presence of any other combustible gases that may be causing detector response

### **Processor and/or Memory Faults**

- Recycle power in attempt to clear problem
- Restore Factory Defaults - This will clear the processor's memory and may correct problem
- Remember to re-enter all customer settings for range and cal gas level after Restore Factory Defaults
- If problem persists, replace the Intelligent Transmitter Module (ITM)

### **Unreadable Display**

- If due to excessive sunlight, install a sunshade to reduce glare

### **Nothing Displayed – Transmitter not Responding**

- Verify condulet has no accumulated water or abnormal corrosion
- Verify required DC power is applied to correct terminals
- Swap with a known-good ITM to determine if ITM is faulty

### **Faulty 4-20mA Output**

If detector has a normal reading with no Faults displayed, and the 4-20 mA signal output is 0mA.

- Check that wiring is properly connected at terminal blocks and through to controller inputs.
- The 4-20mA output loop must be closed to avoid a Loop Fault. If the 4-20mA output is not being used the green wire from the ITM must be connected to the (-) J1 terminal to ensure that it does not create a 4-20mA Fault (see Figure 11: Detector Wire Connections)
- Perform a “Signal Output Check” sequence via Section 3.5.8 and verify 4-20mA output with Current Meter
- Swap with new ITM to determine if the ITM’s 4-20mA output circuit is faulty.
- If the 4-20mA current loop is still out of tolerance, contact Oldham at [support@oldhamgas.com](mailto:support@oldhamgas.com)

### **No Communication - RS-485 Modbus™**

If unit has a normal reading with no Faults displayed and the Modbus™ is not communicating.

- Verify that the correct (and non-duplicated) serial address is entered (per Section 3.5.6)
- Check that wiring is properly connected at terminal blocks and through to controller inputs
- Perform a “Signal Output Check” sequence via Section 3.5.8 and troubleshoot wiring
- Swap with new ITM to determine if the ITM’s serial output circuit is faulty



## Customer Support and Service Policy

Oldham Headquarters

OLDHAM S.A.S.  
Z.I Est – rue Orfila  
CS20417  
62027 Arras Cedex France  
Phone: +33 (0)3 21 60 80 80  
Fax: +33 (0)3 21 60 80 00

- website: [www.oldhamgas.com](http://www.oldhamgas.com)
- customer service: [customerservice@oldhamgas.com](mailto:customerservice@oldhamgas.com)
- technical support: [support@oldhamgas.com](mailto:support@oldhamgas.com)
- repair activities: [r2@oldhamgas.com](mailto:r2@oldhamgas.com)

All Technical Service and Repair activities should be handled by the Oldham Service Department via phone, fax or email at contact information given above. RMA numbers should be obtained from the Oldham Service Department prior to equipment being returned. For on-line technical service, customers should have ready the model number, part number, and serial number of product(s) in question.

## 7. Appendix

### 7.1 Specifications

Sensor Type:	Continuous diffusion/adsorption type Matched-Pair Catalytic Bead type True plug-in replaceable type
Sensor Life:	3-5 years typical
Measuring Range:	0-100% LEL (Lower Explosion Limit)
Accuracy/ Repeatability:	±3% 0-50% LEL; ±5% 50-100% LEL
Response/Clearing Time:	T50 < 10 seconds, T90 < 30 seconds
Zero Drift:	<5% per year
Analog Output:	Linear 4-20mA DC current (1000 ohms maximum loop load @ 24VDC) 0mA            All Fault Diagnostics 2mA            In-Calibration 4-20mA        0-100% full-scale 22mA          Over-range condition
Serial Output:	RS-485 Modbus™ RTU 9600 BPS (9600,N,8,1 Half Duplex)
Status Indicators:	4-digit LED Display with gas concentration full-script menu prompts for AutoSpan, Set-up Options, and Fault Reporting
Faults Monitored:	Operating Temperature, Loop, Input Voltage, Bridge Voltage, Zero, Sensor, Processor, Memory, Calibration
ATEX Marking:	 II 2 G    Ex d IIB+H <sub>2</sub> T4 Gb (Tamb=-40° to +75°C)
Ingress Protection:	NEMA 4X, IP66
Safety Approvals:	ATEX CE Marking SIL2 Certified to IEC 61508
Warranty:	Plug-in detector – 2 years Transmitter – 2 years

**Environmental Specifications**

Operating Temperature:	-40°F to +167°F°; -40°C to +75°C
Storage Temperature:	-40°F to +167°F°; -40°C to +75°C
Operating Humidity:	0-99% RH (Non-condensing)

**Mechanical Specifications**

Dimensions:	
OLCT 700	7"H x 2.2"D; 178mmH x 65mmD
OLCT 710	13.74"H x 5.0"W x 5.12"D; 349mmH x 127mmW x 130mmD
Weight:	
	2.5 lbs; 1.14 kg (OLCT 700 only)
	7.4 lbs; 3.36 kg (OLCT 710 w/aluminum j-box)
	16.4 lbs; 7.44 kg (OLCT 710 w/stainless steel j-box)

**Electrical Specifications**

Power Input:	11-30VDC
Power Consumption:	Normal operation = 68mA (<1.7 watt) Maximum = 85mA (2 watts)
Inrush current:	1.0A @ 24V
RFI/EMI Protection:	Complies with EN 50270:2006 for Type 2 device
Cable Requirements:	
Power/Analog:	3-wire shielded cable Maximum distance is 4000 meters feet with 14 AWG
Serial Output:	2-wire twisted-pair shielded cable specified for RS-485 use Maximum distance is 1200 meters to last detector
I/O Protection:	Over-Voltage, Miss-wiring, EMI/RFI Immunity

## 7.2 Spare Parts, Detector Accessories, Calibration Equipment

Part Number	Spare Parts
DET-927-525500-100	OLCT 700/710 FP Intelligent Transmitter Module (ITM)
DET-602-003152-000	OLCT 700/710 Housing Bottom Assembly (includes Flame Arrestor)
DET-370-201600-700	OLCT 700/710 FP Replacement Plug-in Sensor
DET-500-003087-100	Transient Protection PCA for OLCT 700/710 detector
<b>Detector Accessories</b>	
DET-613-120000-700	Sensor Splashguard with integral Cal Port for OLCT 700/710
DET-943-002273-000	Harsh Environment Sensor guard for OLCT 700/710
DET-327-000000-000	Programming Magnet
DET-960-202200-000	Condensation prevention packet (for J-Box replace annually)
6322420	OLCT 710 ceiling mount
<b>Calibration Accessories</b>	
DET-943-000000-000	Calibration Wind Guard
DET-943-000006-132	Threaded Calibration Adapter
18108011	Span Gas cylinder: 50% LEL Methane (2.5% vol.) balance air Contains 112 liters of gas
18108010	Span Gas cylinder: Zero Air. Contains 112 liters of gas
6128848	0.5 l/min Fixed Flow Regulator for span gas cylinder
<b>Recommend Spare Parts for 2 Years</b>	
DET-927-525500-100	OLCT 700/710 FP Intelligent Transmitter Module (ITM)
DET-602-003152-000	OLCT 700/710 Housing Bottom Assembly (includes Flame Arrestor)
DET-370-201600-700	OLCT 700/710 FP Replacement Plug-in Sensor
DET-500-003087-100	Transient Protection PCA for OLCT 700/710 detector
DET-960-202200-000	Condensation prevention packet (for J-Box replace annually)

### 7.3 OLCT 700/710 FP Drawings

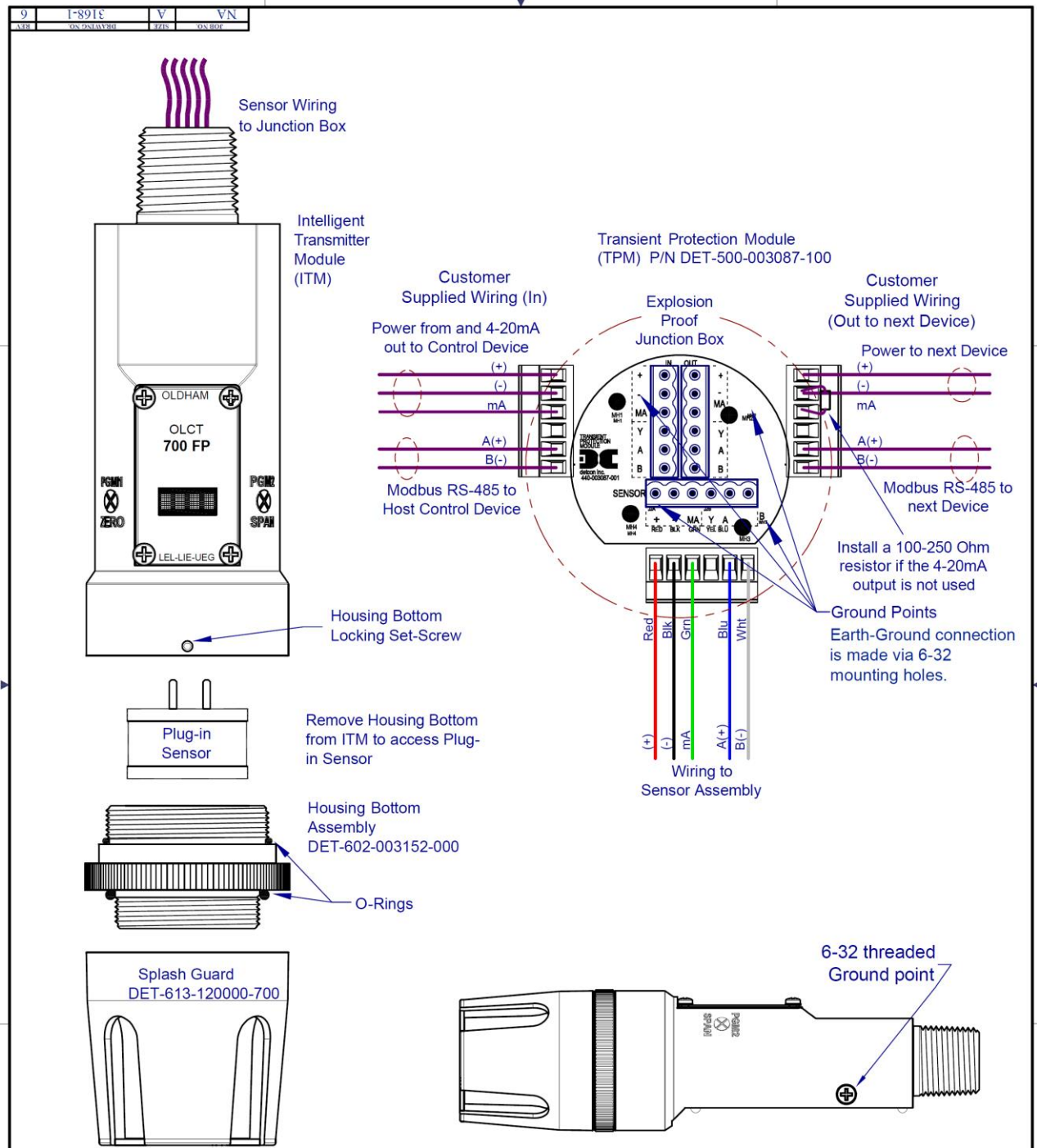

**NOTES:**

P.O. NO.	NA	The information and technical data disclosed by this document may be used and disseminated only for the purposes and to the extent specifically authorized by Oldham S.A.S. in writing. Such information and technical data are proprietary to Oldham S.A.S. and may not be used or disseminated except as provided in the foregoing sentence.
REQ. NO.	NA	
PROJECT NO.	NA	
SERIAL NO.	NA	
PLANT:	NA	

REV.	DATE	DESCRIPTION	DEN	CHKD	APPR	DWG.#	SUBJECT
6	11/08/13	Change Splashguard and Housing	RH	LU	BM	3168	Updates
5	06/25/10	Add this drawing for Aluminium Conduit	RH	SF	BM	3168	Updates
4	01/14/08	Removed yellow wire	RH	SF	BM	3168	Updates
3	04/01/07	TPM Changed	RH	EM	BSJ	3168	Updates
2	11/28/06	Correct pinout on TPM	RH	EM	BSJ	3168	Updates
1							

		OLDHAM S.A.S. ZI EST - ARRAS - FRANCE	
CLIENT:	NA	<b>FP-700 Series Breakaway and Wiring</b>	
PROJECT:	NA	SALES ORDER NO.	3168-1
DRAWN BY:	R HUTSKO	SCALE:	NTS
FIRST ISSUE:	03/30/06	SHEET NO.:	A 6

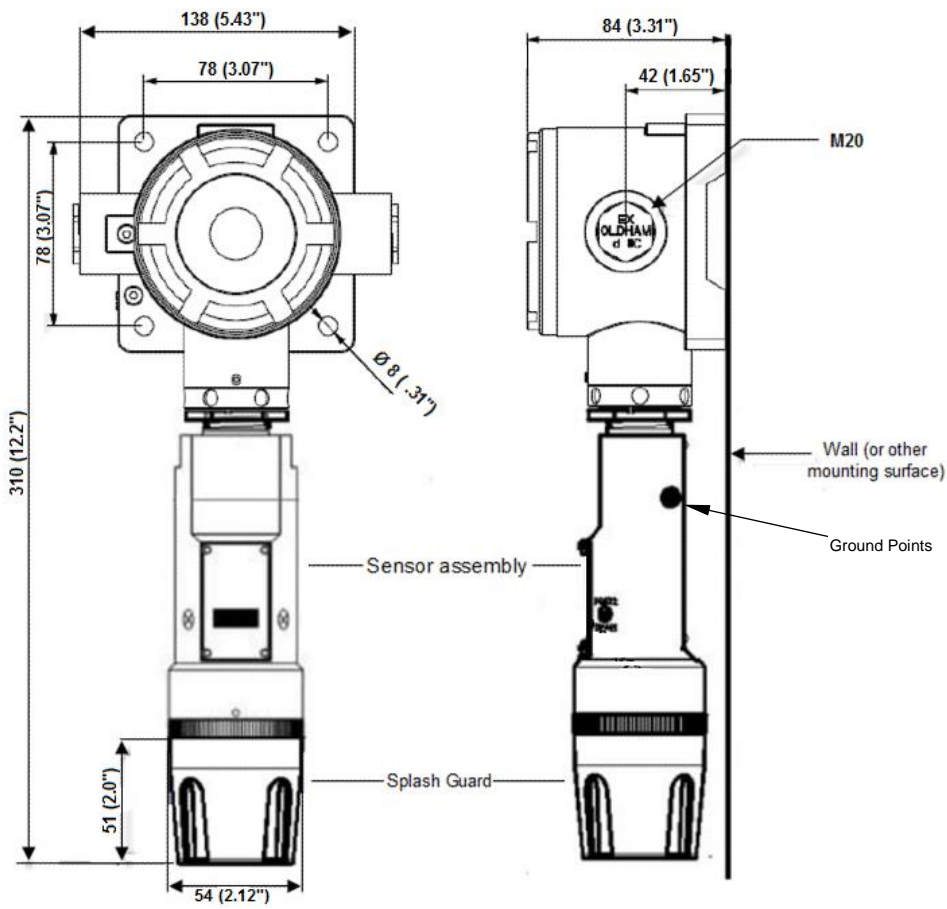

OLCT 710 FP Series Dimensional

This page has been left blank  
intentionally

## 8. EC Declaration of conformity



### Déclaration UE de Conformité EU Declaration of Conformity

La société **Oldham S.A.S.**, Z.I. Est 62000 Arras France, atteste que les  
*Oldham S.A.S. company, Z.I. Est 62000 Arras France, declares that*

#### Détecteurs de gaz OLCT 700 (FP, TP, IR) Gas detectors OLCT 700 (FP, TP, IR)

sont conformes aux exigences des Directives Européennes suivantes :  
*comply with the requirements of the following European Directives :*

#### I) Directive Européenne ATEX 2014/34/UE du 26/02/14: Atmosphères Explosives *European Directive ATEX 2014/34/UE dated from 26/02/14: Explosive Atmospheres*

Normes harmonisées appliquées : EN 60079-1:07 ('d')

Normes de référence appliquées : EN 60079-0:09

Note: l'équipement n'est pas impacté par les modifications majeures de la version harmonisée EN 60079-0:2012/A11:2013  
*(the equipment is not impacted by the major changes of EN 60079-0:2012/A11:2013 harmonized version)*

Attestation CE de Type du matériel :  
*EC type examination certificate*

**DEKRA 14ATEX0122 X**

Catégorie (category)/Marquage (marking) :

 **II 2 G**  
**Ex d IIB+H2 T4 Gb**  
(-40°C<Ta<+75°C)

Notification Assurance Qualité de Production :  
*Notification of the Production QA*

**INERIS 00 ATEX Q403**

Délivré par l'Organisme notifié numéro 0080 :  
*Issued by the Notified Body n°0080*

**INERIS, Parc Alata**  
60550 Verneuil en Halatte France

#### II) Directive Européenne CEM 2014/30/UE du 26/02/14: Compatibilité Electromagnétique *European Directive EMC 2014/30/UE dated from 26/02/14: Electromagnetic Compatibility*

Normes harmonisées appliquées :  
*Harmonised applied Standard*

**EN 50270:06** CEM-Appareils de détection de gaz  
(Type 1 & 2) *EMC- apparatus for the detection of gases*

#### Sécurité de Fonctionnement (Functional Safety)

Normes appliquées  
*Applied Standards*

**EN 61508:11**

Niveau d'intégrité de Sécurité  
*Safety Integrity Level*

**Capability SIL 2** selon certificats EXIDA (*according to EXIDA certificates*) No. DC 1408062-C001 (OLCT 700 IR), -C003 (OLCT 700 FP) et (*and*) -C004 (OLCT 700 TP)

Arras, le 20 avril 2016 (April 20<sup>th</sup>, 2016)



**Oldham S.A.S.**  
Z.I. EST - C.S. 20417  
62027 ARRAS Cedex - FRANCE  
www.oldhamgas.com



Michel Spellemaeker  
Global Director of Product Management

UE\_atex\_OLCT 700\_FP TP IR\_revA





**Déclaration UE de Conformité**  
**EU Declaration of Conformity**

La société **Oldham S.A.S.**, Z.I. Est 62000 Arras France, atteste que les  
**Oldham S.A.S. company**, Z.I. Est 62000 Arras France, declares that

**Détecteurs de gaz OLCT 710 (FP, TP, IR)**  
**Gas detectors OLCT 710 (FP, TP, IR)**

sont conformes aux exigences des Directives Européennes suivantes :  
*comply with the requirements of the following European Directives :*

**I) Directive Européenne ATEX 2014/34/UE du 26/02/14: Atmosphères Explosives**  
*European Directive ATEX 2014/34/UE dated from 26/02/14: Explosive Atmospheres*

Normes harmonisées appliquées : EN 60079-0: 2012/A11:2013 (Règles générales)  
EN 60079-1:2007 ('d')

Attestation CE de Type du matériel :  
*EC type examination certificate*

**INERIS 15ATEX0040X**

Catégorie (*category*)/Marquage (*marking*) :

 **II 2 G**  
**Ex d IIB+H2 T4 Gb**  
(-40°C<Ta<+70°C)

Notification Assurance Qualité de Production :  
*Notification of the Production QA*

**INERIS 00 ATEX Q403**

Délivré par l'Organisme notifié numéro 0080 :  
*Issued by the Notified Body n°0080*

**INERIS, Parc Alata**  
60550 Verneuil en Halatte France

**II) Directive Européenne CEM 2014/30/UE du 26/02/14: Compatibilité Electromagnétique**  
*European Directive EMC 2014/30/UE dated from 26/02/14: Electromagnetic Compatibility*

Normes harmonisées appliquées :  
*Harmonised applied Standard*

**EN 50270:06** CEM-Appareils de détection de gaz  
(Type 1 & 2) *EMC- apparatus for the detection of gases*

**Sécurité de Fonctionnement (Functional Safety)**

Normes appliquées  
*Applied Standards*

**EN 61508:11**

Niveau d'intégrité de Sécurité  
*Safety Integrity Level*

**Capability SIL 2** selon certificats EXIDA (*according to EXIDA certificates*) No. DC 1408062-C001 (OLCT 700 IR), -C003 (OLCT 700 FP) et (*and*) -C004 (OLCT 700 TP)

Arras, le 20 avril 2016 (April 20<sup>th</sup>, 2016)



**Oldham S.A.S.**  
Z.I. EST - C.S. 20417  
62027 ARRAS Cedex - FRANCE  
www.oldhamgas.com

Michel Spellemaeker  
Director of Product Management

UE\_atex\_OLCT 710\_FP TP IR\_revA

## 9. Revision Log

Revision	Date (dd/mm/yyyy)	Changes made	Approval
A.0	30/09/2014	Release	MS
B.0	18/06/2015	Addition of the OLCT 710	MS
B.1	29/09/2015	EC Declaration Update	MS
B.2	01/03/2016	Removal of ¾ NPT entry types	MS
C.0	20/04/2016	EU Declaration Update	YM





## **EUROPEAN PLANT AND OFFICES**

Z.I. Est – rue Orfila CS 20417 – 62027 Arras Cedex FRANCE  
Tel: +33 (0)3 21 60 80 80 – Fax: +33 (0)3 21 60 80 00  
Website: <http://www.oldhamgas.com>

AMERICAS  
Tel: +1-713-559-9280  
Fax: +1-281-292-2860  
[americas@oldhamgas.com](mailto:americas@oldhamgas.com)

ASIA PACIFIC  
Tel: +86-21-3127-6373  
Fax: +86-21-3127-6365  
[sales@oldhamgas.com](mailto:sales@oldhamgas.com)

EUROPE  
Tel: +33-321-608-080  
Fax: +33-321-608-000  
[info@oldhamgas.com](mailto:info@oldhamgas.com)