

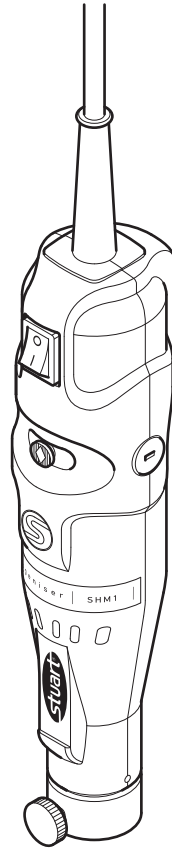

Homogeniser SHM1 & SHM3

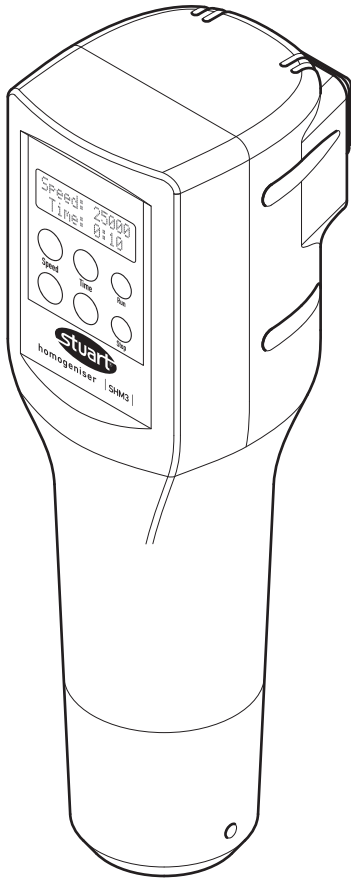

Instruction Manual STU0005 / Version 1.0

Section 1 - Introduction

Thank you for purchasing this Stuart product. To get the best performance from the equipment, and for your own safety, please read these instructions carefully before use.

If the equipment is not used in the manner described in this manual and with accessories other than those recommended by the manufacturer, the protection provided may be impaired.

1.1 General Description

The SHM1 and SHM3 homogenisers are variable speed, hand-held or retort-stand mounted homogenisers. They combine a high-speed, high-torque motor with a choice of autoclavable rotor-stator generator probes. The model SHM1 homogeniser is suitable for most laboratory applications such as tissue homogenisation, production of emulsions and suspensions, cell disruption and protein extraction. It is lightweight and can be hand-held or mounted to a retort stand for lengthier processing. The SHM3 is a powerful, versatile and durable homogeniser that can handle virtually any processing application, making it ideal for tougher samples and larger volumes.

The SHM1 and SHM3 are supplied with a post clamp assembly for mounting it to a retort stand. A retort stand assembly, catalogue number SHM/STAND, is available as an accessory for both models. Both models are also supplied with a tool kit for dismantling the rotor-stator generator probes for easy cleaning.

1.2 Important Safety Advice

Users should be aware of the following safety advice:

- ❖ **SHOCK HAZARDS OR UNSAFE PRACTICES ARE DANGEROUS** as they can cause severe personal injury, fire or death.
- ❖ **DO NOT** use combustible substances near hot objects.
- ❖ **DO NOT** use the equipment in hazardous atmospheres.
- ❖ **DO NOT** operate or handle any part of the equipment with wet hands or use on surfaces that may become flooded.
- ❖ **NEVER** move the equipment while still connected to the power supply.
- ❖ **HIGH TEMPERATURES ARE DANGEROUS** as they can cause serious burns to operators and ignite combustible material.
- ❖ **USE CARE AND WEAR PROTECTIVE GLOVES TO PROTECT HANDS.**
- ❖ **NEVER** lift or carry the equipment during operation.
- ❖ **DO NOT** position the equipment unit so that it is difficult to disconnect from the mains supply using the mains plug.
- ❖ The mains outlet socket used should be located close to the equipment and readily identifiable and accessible to users.
- ❖ **DO NOT** leave equipment switched on and it is not recommended to leave any heating apparatus unattended during operation.
- ❖ The equipment should be carried using both hands.
- ❖ The equipment is fitted with a power outage recovery mode. In case of mains interruption you can choose if you want the rotation to continue or stop once the power is restored, see section 3.4. In case of fault or mechanical failure the equipment will NOT continue to operate on removal of fault.
- ❖ **DO NOT** allow the motor to be submerged in any liquid.
- ❖ **DO NOT** use the equipment if it has been damaged in any way.
- ❖ **DO NOT** use accessories that are not recommended by Stuart.
- ❖ **DO NOT** attempt to stop the equipment by hand.
- ❖ **DO NOT** attempt to modify this equipment in any way.
- ❖ **DO NOT** run the generator probes in air, only in the presence of fluid.

1.3 Symbols Defined



1.4 Electrical Requirements



THIS INSTRUMENT MUST BE GROUNDED

Before connection please ensure that the line supply corresponds to the power requirements below:

Model	Power	Supply requirements
SHM1/UK	125 W	220 V - 240 V ~ 50 Hz
SHM1/EURO	125 W	220 V - 240 V ~ 50 Hz
SHM3	850 W	220 V - 240 V ~ 50 Hz

The SHM1 is supplied with either a UK 3-pin fitted plug or a "Schuko" 2-pin fitted plug depending on which version you have ordered. The SHM3 is provided with two power cables consisting of a UK 3-pin and a "Schuko" 2-pin plug for 230 V installations.

Choose the power cable appropriate for your electrical installation and discard the others. Should none of the power cables be suitable for connecting to the power supply, replace the plug with a suitable alternative.

THIS OPERATION SHOULD ONLY BE UNDERTAKEN BY A QUALIFIED ELECTRICIAN.

NOTE: Refer to the equipment rating plate to ensure that the plug and fusing are suitable for the voltage and wattage stated. The wires in the mains cable are as follows:

230 V a.c.

HOT/LIVE - BROWN

NEUTRAL - BLUE

EARTH - GREEN/YELLOW

The appropriate power cable and power adaptor combination should be connected to the equipment BEFORE connection to the mains supply.

Should the mains lead require replacement please contact cpspares@coleparmer.com.



IF IN DOUBT CONSULT A QUALIFIED ELECTRICIAN

Section 2 - Installation

2.1 Unpacking

Before discarding the packaging check that all parts are present and correct.

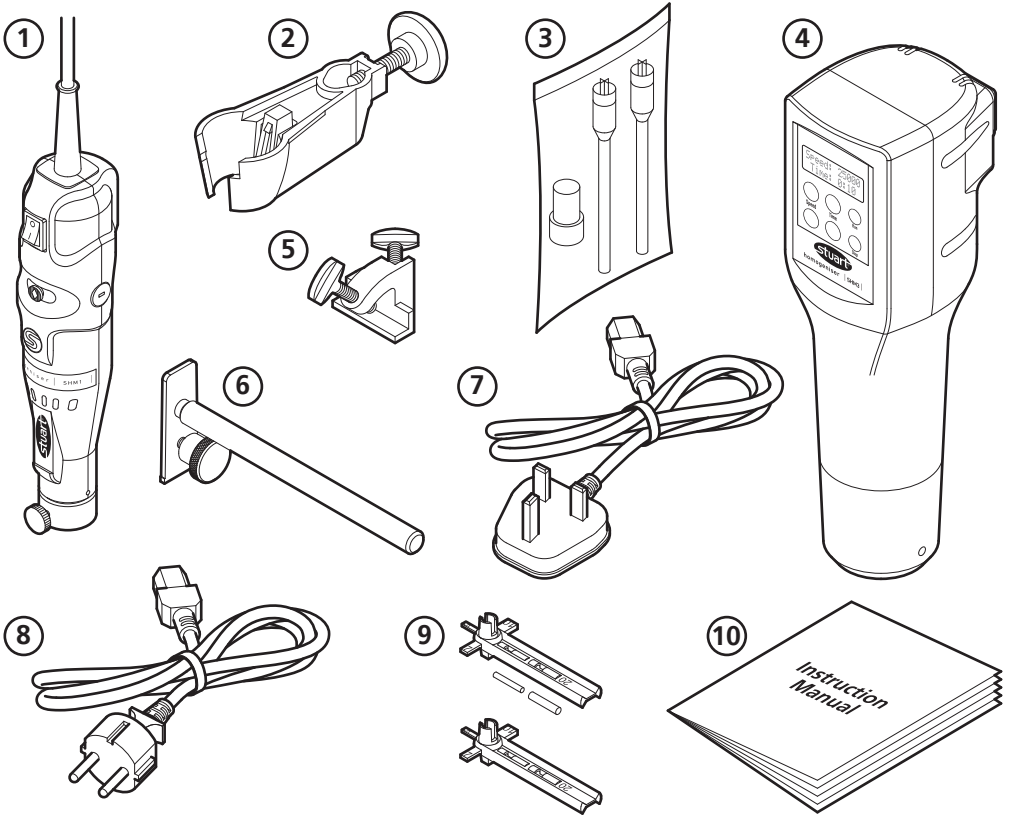

Ref. No.	Description	SHM1	SHM3
1	Motor body	x1	-
2	Post clamp	x1	-
3	Plastic disposable probes x2 and adaptor (SHM/ADAPT)	x1	-
4	Motor body	-	x1
5	Post clamp	-	x1
6	Cross rod	-	x1
7	UK power lead	-	x1
8	EU power lead	-	x1
9	Probe tool x2 and bearing press x2	x1	x1
10	Instruction manual	x1	x1

2.2 Installation Conditions

This equipment is designed to operate safely under the following conditions:

- ❖ For indoor use only
- ❖ Use in a well ventilated area
- ❖ Ambient temperature range 5°C to 40°C (41°F to 104°F)
- ❖ Altitude to 2000m (6500 ft)
- ❖ Relative humidity not exceeding 80% (temperature 31°C) decreasing to 50% (temperature 40°C) and free from condensation
- ❖ Mains supply fluctuations not exceeding 10% of nominal
- ❖ Overvoltage category II IEC60364-4-443
- ❖ Pollution degree 2 IEC664
- ❖ Use with a minimum distance all round of 300mm (12in.) from walls or other items

Place the equipment on a clean, firm, level surface which is free from drafts. Avoid installation on a slippery surface or on a surface prone to vibration or on a surface prone to flooding.

2.3 Overview

SHM1

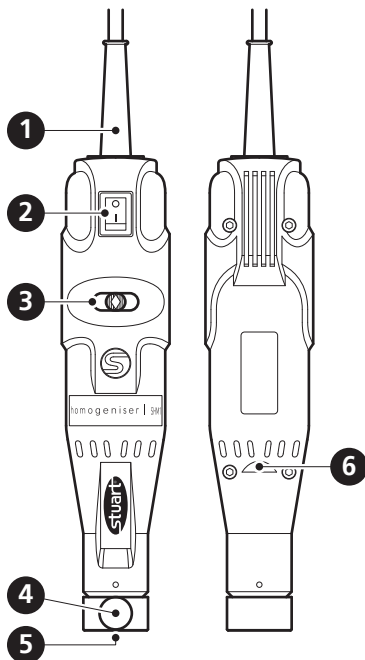

1	Power lead
2	On/Off switch
3	Speed control
4	Thumb screw
5	Generator probe coupling
6	Clamp notch

SHM3

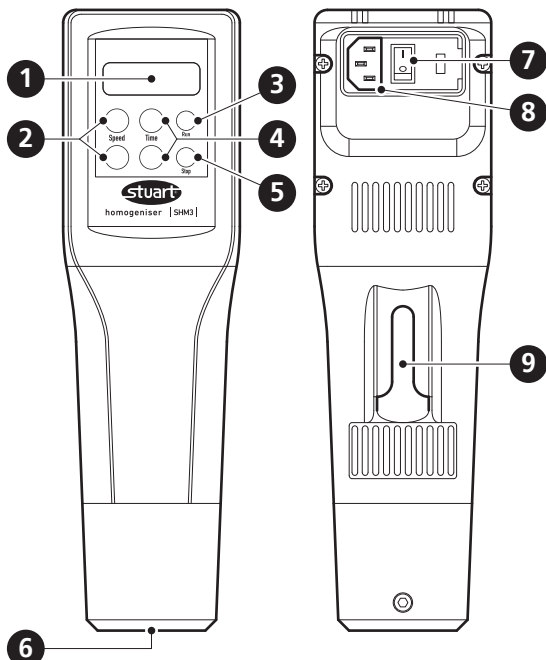

1	Display	6	Generator probe coupling
2	Speed control	7	On/Off switch
3	Timer control	8	Power lead socket
4	Run button	9	Clamp port
5	Stop button		

2.4 Assembly



Before assembling your homogeniser you must ensure the power switch is in the OFF position and the mains power is disconnected.



If you are using the optional retort stand (SHM/STAND) we recommend you assemble the stand before you insert the generator probes into the SHM1 or SHM3 homogeniser.

Assemble the stand by screwing the post into the base plate until it is securely tightened.

2.4.1 SHM1

If you are using a stand follow steps 1 - 3, otherwise you will only need to follow step 3.

1. Slide the **Motor body** ① into the opening on the **Post clamp** ② and push down firmly until it locks into place.
2. Loosen the locking handle and carefully slide the unit up or down to the desired height and lock in place.
3. The SHM1 uses a quarter-turn bayonet mount. Simply push the probe into the motor housing as far as possible, turn anti-clockwise, release and secure with thumb screw.

To remove the SHM1 from the stand, press the **Release button** on the back of the opening of the post clamp assembly and lift the unit from the cradle.

Removal of the probe is the opposite of installation.

If using plastic disposable rotor-generator probes, the adapter SHM/ADAPT will be required. The adapter also uses a quarter-turn bayonet mount. Push the adapter into the motor housing as far as possible, turn anti-clockwise, release and secure with thumb screw. Next, insert the plastic probes using the same method.

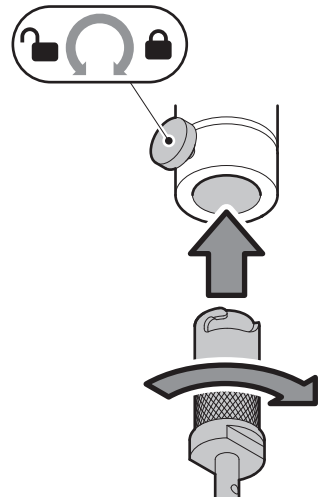
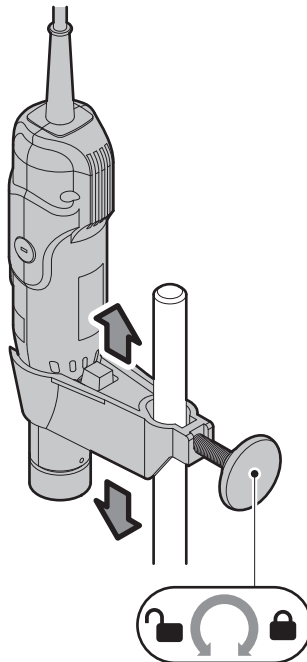
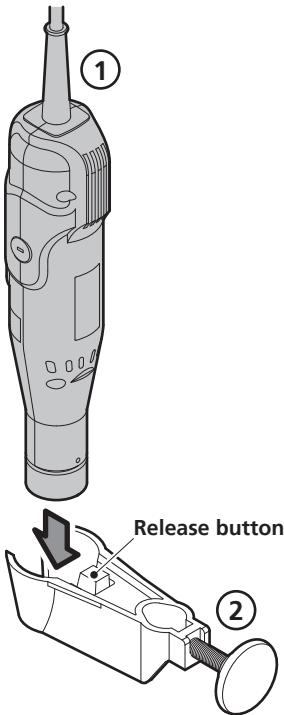

2.4.1 SHM3

If you are using a stand follow steps 1 - 4, otherwise you will only need to follow step 4.

1. Insert the **Cross rod** (6) into the port at the back of the **Motor body** (4) secure by turning the thumb screw clockwise to lock.
2. Slide the **Post clamp** (6) onto the cross rod and lock in place, a minimum 25mm of the rod should protrude from the back of the post clamp.

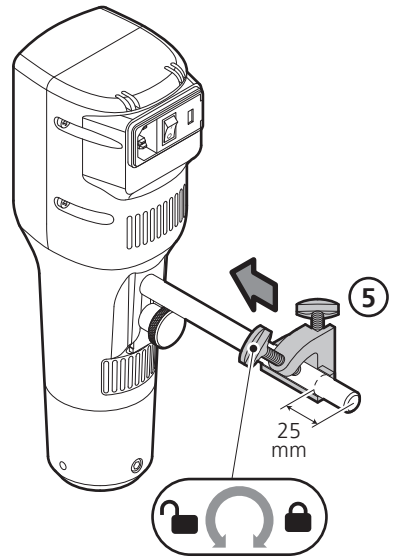
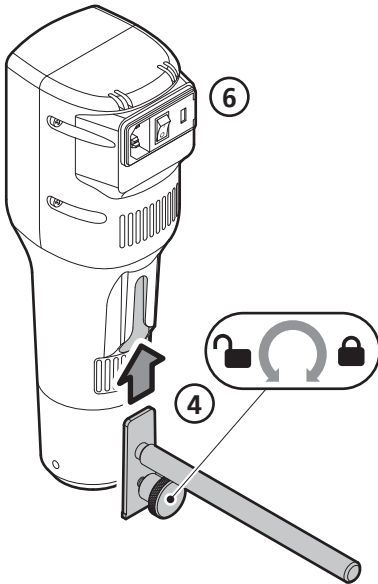

3. Slide the post clamp onto the post and carefully slide the unit up or down to the desired height and lock in place.
4. The SHM3 uses a quarter-turn bayonet mount. Simply push the probe into the motor housing as far as possible, turn anti-clockwise and release.

To remove the SHM3 from the stand perform the above steps in reverse order.

Removal of the probe is the opposite of installation.

If using plastic disposable rotor-generator probes, the adapter SHM/ADAPT will be required. The adapter also uses a quarter-turn bayonet mount. Push the adapter into the motor housing as far as possible, turn anti-clockwise and release. Next, insert the plastic probes using the same method.

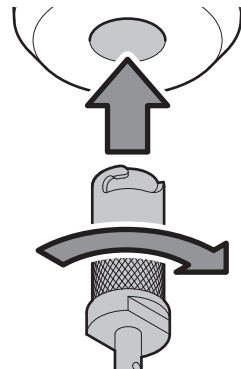
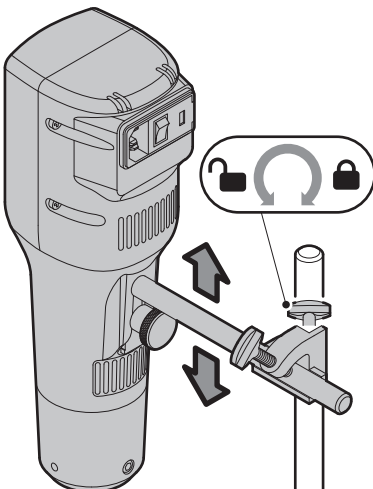

Section 3 - Operation

3.1 Theory of operation

The rotor shaft part of the probe is coupled directly to the drive motor of the homogeniser. When attached, the rotor shaft can spin up to 35,000rpm; this makes up the rotor part of the rotor-stator generator probe. The tube/collar assembly which fits over the rotor shaft is attached to the motor housing but does not spin. This is the stator part of the rotor-stator generator probe.

As the rotor knife spins within the tube/collar assembly, it creates a pumping action, pulling the sample into the open end of the probe and forcing it out through the windows in the tube. This sets up a shearing action, reducing the particle size of the sample. The speed differential between the rapidly moving portion and the relatively stationary portion of the sample sets up a second force called cavitation which pulls the sample apart, further reducing the particle size.

Processing efficiency can be affected by:

- ❖ Amount of material processed vs. size and speed of the generator probe.
- ❖ Container geometry (round vessels encourage swirling, while fluted or cornered vessels disrupt flow patterns for more effective mixing/processing).
- ❖ Processing speed vs. optimal speed.
- ❖ Size and type of material and flow characteristics (material particles must be small enough to be carried into the generator head for optimal processing).

3.2 SHM1 operation

NOTE: As a safety precaution, it is recommended that eye protection is worn when using the homogenisers to protect the user from potential splashes.

1. Remove the protective cap from the tip of the probe.
2. Insert the probe to a depth of one third to one half of the liquid height.

NOTE: Heavy sediments may require deeper immersion and this can be optimised by observation during processing. The top hole of the probe should not be immersed in the sample as this could result in liquid being drawn into the lower motor bearing.

When using disposable plastic probes, the probes should not be immersed above the cone leading up to the motor drive during processing, since liquid may otherwise be drawn up the shaft and contaminate the coupling.

3. Ensure the speed control switch is in the far left-hand position.
4. Switch the power switch to ON and slide the speed control button to the required processing speed.
For most samples, three to four short bursts at top speed should be sufficient for complete homogenisation of the sample.
5. When processing is complete, switch the power switch to OFF and remove the probe for cleaning*. Replace the protective cap on the end of the probe when not in use.

*Please see section 5.2 for details of how to clean the rotor-stator generator probes.

The motor drive housing should be wiped off after use, especially when concentrated and potentially damaging liquids are used during processing. Never use solvents to clean the unit or accessories.

3.3 SHM3 operation

NOTE: As a safety precaution, it is recommended that eye protection is worn when using the homogenisers to protect the user from potential splashes.

1. Remove the protective cap from the tip of the probe.
2. Insert the probe to a depth of one third to one half of the liquid height.

NOTE: Heavy sediments may require deeper immersion and this can be optimised by observation during processing. The top hole of the probe should not be immersed in the sample as this could result in liquid being drawn into the lower motor bearing.

When using disposable plastic probes, the probes should not be immersed above the cone leading up to the motor drive during processing, since liquid may otherwise be drawn up the shaft and contaminate the coupling.

3. Switch the power switch to ON.
4. Set the speed using the Up and Down arrows.
5. Set the timer using the Up and Down arrows. To set the unit to constant run set the timer above 9:59 or below 0:01. The display will read Constant Run.
6. To start press Run. For a delayed start, press and hold Run for 3 seconds. The unit will display a 30 second countdown before running.

For most samples, three to four short bursts at top speed should be sufficient for complete homogenisation of the sample.

7. When processing is complete, switch the power switch to OFF and remove the probe for cleaning*. Replace the protective cap on the end of the probe when not in use.

*Please see section 5.2 for details of how to clean the rotor-stator generator probes.

The motor drive housing should be wiped off after use, especially when concentrated and potentially damaging liquids are used during processing. Never use solvents to clean the unit or accessories.

Section 4 - Accessories and Spare Parts

4.1 Optional Accessories

Part Code	Description
SHM/STAND	Retort stand assembly
SHM/ADAPT	Probe adaptor (for use with disposable plastic probes)
SHM/5	Generator probe 5mm x 75mm (flat bottom)
SHM/7	Generator probe 7mm x 115mm (saw tooth)
SHM/10	Generator probe 10mm x 115mm (saw tooth)
SHM/20	Generator probe 20mm x 195mm (saw tooth)
SHM/DISP	Generator probe, plastic disposable 7mm x 110mm (hard tissue)

Please visit www.stuart-equipment.com for a full list of available accessories.

4.2 Spare Parts

Please contact your local sales specialist or email cpspars@coleparmer.com to enquire about available spares.

Section 5 - Maintenance, Servicing and Cleaning



WARNING: Before attempting any maintenance, servicing or cleaning, ensure that the equipment has been allowed to cool down.



WARNING: Ensure the equipment is disconnected from the power supply before attempting any maintenance, servicing or cleaning.

5.1 Routine Maintenance

Ensure the external surfaces of the unit are clean and free from dust. The sample area should always be kept clean and any accidental spillage should be wiped away immediately. To give added protection when not in use, the equipment should be disconnected from the mains supply. Follow the advice below for cleaning your equipment:

Motor

Ensure the motor is switched off and disconnected from the mains supply before cleaning. Wipe down the unit with a soft damp cloth and a mild detergent solution. Do not use bleach or abrasives. Do not allow cleaning liquids to ingress inside the equipment. Never immerse the unit, cables or plugs in water or any other liquids. Allow any wet surfaces to dry before re-connecting to the mains supply and commencing use.



WARNING: This product does not contain bio-seals as per EN 61010-1-2010 and cannot provide any level of containment in case of a spill or release of toxic, radioactive, or pathogenic micro-organisms thus these materials are not recommended to be used in this product.

NOTE: Do not use solvents for cleaning any parts of this equipment.

In Case of Accidental Spillage



WARNING: Do not touch if a spillage/breakage has occurred. Disconnect the power directly at the power supply source.

If any part of the unit has been exposed to liquid, it cannot be assumed to meet all the safety requirements of EN 61010-1-2010 until the drying out process has been fully completed and all safety requirements are met before the unit is used again.

In Case of Contamination



WARNING: The following procedure is intended as a guide. Should spillage of a toxic or hazardous fluid occur, then additional special precautions may be necessary.

If the equipment has been exposed to contamination, the Responsible Body is responsible for carrying out appropriate decontamination. If hazardous material has been spilt on or inside the equipment, decontamination should only be undertaken under the control of the Responsible Body with due recognition of possible hazards. Before using any cleaning or decontamination method, the Responsible Body should check with the manufacturer that the proposed method will not damage the equipment. Prior to further use, the Responsible Body shall check the electrical safety of the unit. Only if all safety requirements are met can the unit be used again.

NOTE: In the event of this equipment or any part of the unit becoming damaged or requiring service, the item(s) should be returned to the manufacturer for repair accompanied by a decontamination certificate. Copies of the Certificate are available from the Distributor/Manufacturer.

At the end of its service life, the product must be accompanied by a Decontamination Certificate.

5.2 Disassembly and Cleaning of Rotor-stator Generator Probes

Stainless steel probes: disassembly

The stainless steel probes are easily disassembled for cleaning. Refer to the illustration below and follow the instructions given.

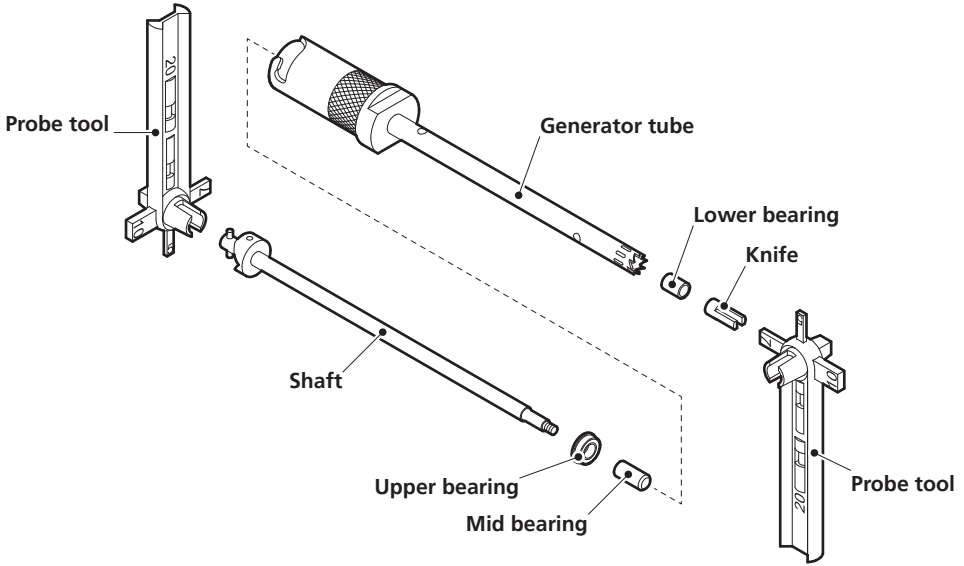

1. Insert the proper size probe tool into the knife end of the probe to hold the **Knife** (the tool is marked 5, 7, 10 or 20 which corresponds to the diameter of the probe in mm).
2. Insert the second probe tool over the driven end of the generator tube.

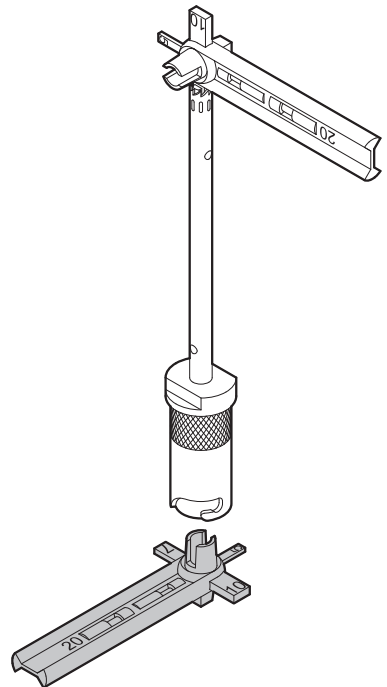
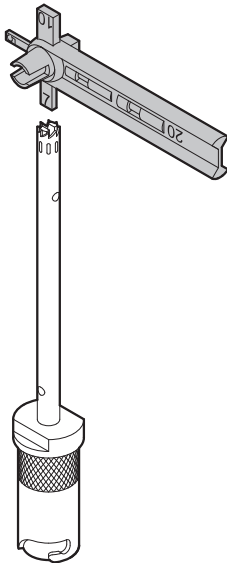

3. Hold both tools and carefully turn the upper probe tool anti-clockwise to unscrew the shaft from the knife.

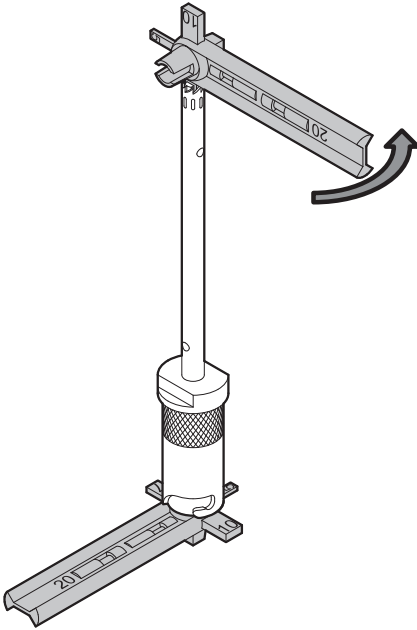

4. Remove the knife and pull the shaft out of the tube.

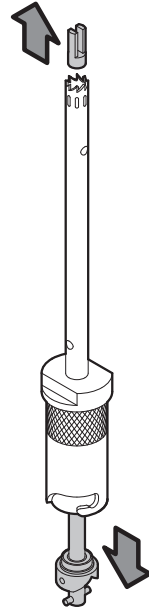

5. Remove the upper bearing from the shaft. 195mm and longer probes have mid-bearings which can be autoclaved inside the tube.

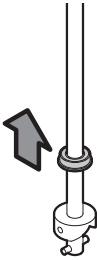

6. If cleaning a 5mm or 7mm probe, thread the appropriate bearing press onto the end of the shaft.



7. Insert the shaft back into the generator tube and press out the lower bearing.

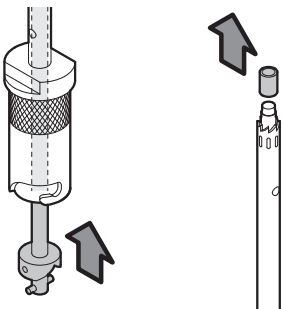

8. Remove the bearing press from the shaft before cleaning the probe parts.

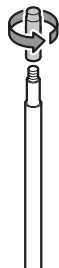

NOTE: Inspect the bearing for wear or black particles. Clean any dirt from the bearing before reassembly. Replace the bearing if worn or damaged. New bearings must be run-in before initial use, placing the probe in clean water, as follows:

1. Run 4 minutes on lowest motor setting.
2. Run 5 minutes on medium motor setting.
3. Run 1 minute on highest motor setting.
4. Disassemble generator probe.
5. Clean bearings of run-in dust.
6. Reassemble generator probe.

Autoclaving the stainless steel probes

The generator probes may be sterilised by autoclaving up to 121°C. If the probe contains all Teflon bearings, then it can be autoclaved as an assembly.

Stainless steel probes: reassembly

1. Insert the lower bearing into the knife end of the generator tube.



2. For 5mm and 7mm probes, use the appropriate bearing press to set the lower bearing by using it to gently push the bearing into position in the tube. Remove the bearing press, leaving the bearing in place.



3. Slide the upper bearing onto the shaft so that the flanged side of the bearing is resting against the bottom of the shaft spacer.

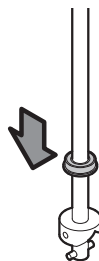

4. Insert the shaft into the driven end of the generator tube.

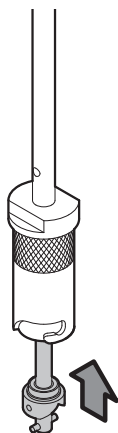

5. Place the upper probe tool over the driven end of the generator tube. Holding it in place, invert the probe so that the knife end points up.

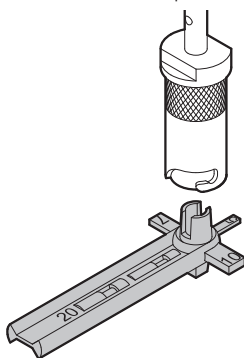

6. Insert the knife into the processing end of the generator tube and turn clockwise to begin threading it onto the shaft.

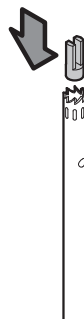

7. Using the other probe tool, select the correct size for the probe and insert it into the knife.
8. Turn the upper probe tool clockwise until it stops. **DO NOT TIGHTEN OR TORQUE THE KNIFE** as this may cause it to bend or break.

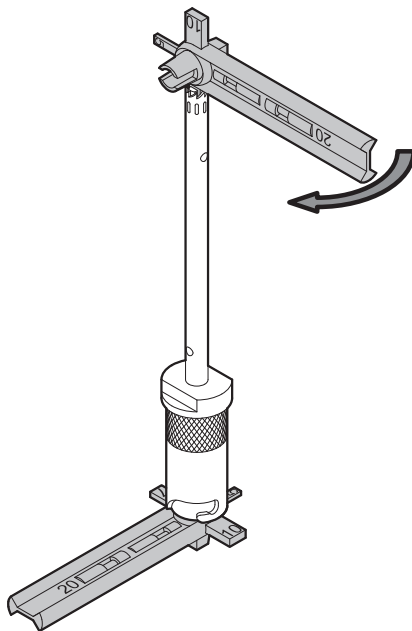
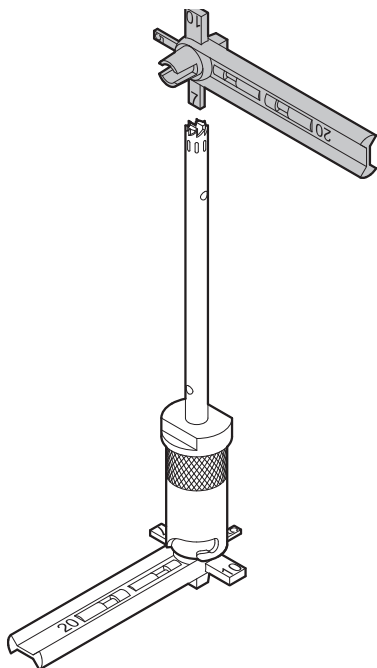

9. The generator should spin freely, if not, disassemble and reassemble the probe to ensure the bearings are fully seated.
10. Run the generator probe in clean water for 5 minutes at slow speed, 5 minutes at medium speed then 1 minute at full speed. The knife is self-tightening and running the generator in water will tighten the knife onto the shaft to the proper torque.

Disposable plastic probes

Non-sterile disposable plastic probes are ideal for situations where molecular contamination between samples cannot be tolerated. The plastic probes are manufactured of polycarbonate and an amorphous thermoplastic polythermide and are designed to be disposed of after a single use. However they can be cleaned and autoclaved up to seven times for repeated use if required. The probes have good chemical resistance to weak acids, chlorides, hypochlorite solution (5%) and many other chemicals. The probes are not recommended for extended use with phenol or guanidine-based reagents and should be disposed of after a single use in these chemicals. If any cracking or brittleness of the probe is detected, it is recommended that it is discarded.

NOTE: The plastic disposable probes are not pre-sterilised. If this is a requirement please use one of the following methods of sterilisation:

- ❖ Autoclave up to 121°C
- ❖ Ethylene oxide
- ❖ Formaldehyde (g)
- ❖ Glutaraldehyde (2%)
- ❖ Gamma irradiation up to 5MRAD

UV irradiation is NOT recommended.

For biological disinfection of the disposable rotor-stator generator probes the following reagents can be used:

- ❖ Alcohol (70%)
- ❖ Hypochlorite (5%)
- ❖ Formaldehyde (40%)

5.3 Service, Repairs and Support

Any service, repairs or replacement of parts MUST be undertaken by suitably qualified personnel. Only spare parts supplied or specified by Cole-Parmer or its agents should be used. Fitting of non-approved parts may affect the performance and safety features designed into the instrument. For a comprehensive list of parts required by service engineers conducting internal repairs please contact the service department quoting the model and serial number:

Email: cpservice@coleparmer.com

Tel: +44 (0)1785 810475

For technical support enquiries please contact:

Email: cptsupport@coleparmer.com

Tel: +44 (0)1785 810433

5.4 Warranty

Cole-Parmer Ltd. warrants this instrument to be free from defects in material and workmanship, when used under normal laboratory conditions, for a period of **one (1)** year. In the event of a justified claim Cole-Parmer will replace any defective component or replace the unit free of charge. This warranty does NOT apply if damage is caused by fire, accident, misuse, neglect, incorrect adjustment or repair, damage caused by incorrect installation, adaptation, modification, fitting of non-approved parts or repair by unauthorised personnel.

Cole-Parmer Ltd,

Beacon Road,

Stone,

Staffordshire,

ST15 0SA,

United Kingdom

Email: cpservice@coleparmer.com

Tel: +44 (0)1785 810475

Web: www.stuart-equipment.com

Section 6 - Environmental Protection

6.1 Packaging Material



Packaging materials have been carefully selected so they can be sorted for recycling.

6.2 Waste Electrical and Electronic Equipment Directive (WEEE)



At the end of your product and accessories life, it must not be discarded as domestic waste. Ref: EU Directive 2012/19/EU on Waste Electrical and Electronic Equipment Directive (WEEE). Please contact your distributor / supplier for further information. For end users outside of the EU consult applicable regulations.

Section 7 - Technical Specification

7.1 General Specification

	SHM1	SHM3
Speed	5000 - 35000rpm	5000 - 25000rpm
Capacity	0.03ml - 100ml	200ml - 2 litres
Power	220 - 240V, 50Hz	
Motor Power	125 W	850 W

7.2 Weights and Dimensions

SHM1 - 0.5kg

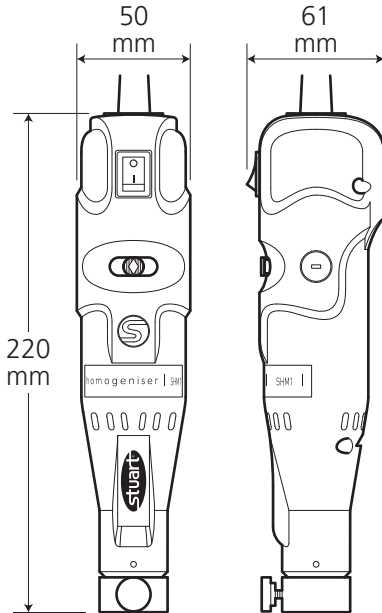

SHM3 - 1.6kg

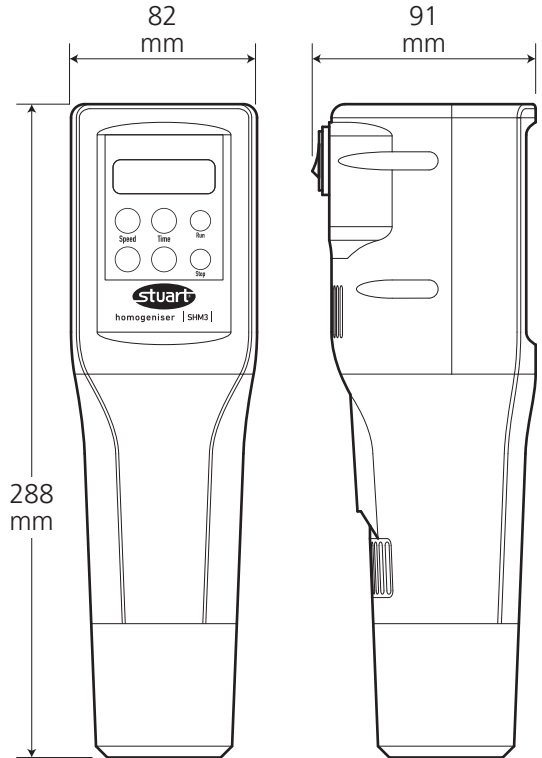

Section 8 - Trouble Shooting

Product	Problem	Cause	Solution
SHM1 / SHM3	The unit is plugged in and turned on but is not functioning	Power cord or mains socket has been turned off / disconnected	Check power cord connectors. Check mains socket for power to the outlet.
SHM1 / SHM3	The motor is turned ON and makes a "buzzing" sound but is not working.	The brushes may be worn or not installed correctly.	Please contact the Service department.
SHM1 / SHM3	Motor unit operating speed declines, stalls intermittently, or stops completely.		
SHM1 / SHM3	Teflon bearing wears quickly.		
SHM1 / SHM3	Excessive splashing in sample tube.	Fluid level may be too low in the tube.	Immerse the probe deeper into the fluid.
SHM3	Motor is not turning. Error 1 is displayed.	Motor has overheated.	Unplug and allow to stand for 1 hour at room temperature, then restart.
		Motor is being obstructed.	Remove generator probe and attempt to run the motor.
			Check that the generator probe (when it has been removed from the motor) spins freely.
		Check for foreign objects inside the generator probe.	
SHM3	Motor has failed to reach the desired speed, or is drawing too much power to reach speed desired. Error 2 is displayed	Generator probe is too large for the desired speed or the sample is too large / viscous to be processed.	Reduce speed.
			Reduce the generator probe size.
			Reduce the viscosity of the sample.



This product meets the applicable harmonized standards for radio frequency interference and may be expected not to interfere with, or be affected by, other equipment with similar qualifications. We cannot be sure that other equipment used in its vicinity will meet these standards

and so we cannot guarantee that interference will not occur in practice. Where there is a possibility that injury, damage or loss might occur if equipment malfunctions due to radio frequency interference, or for general advice before use, contact the manufacturer.



EU Declaration of Conformity

Product	Laboratory Equipment	File Number	P225
Manufacturer	Cole-Parmer Ltd Beacon Road Stone, Staffordshire ST15 0SA United Kingdom		

This declaration of conformity is issued under the sole responsibility of the manufacturer

Object of Declaration Homogenisers
(reference the attached list of catalogue numbers)

The object of the declaration described above is in conformity with the relevant Union Harmonisation Legislation:

Low Voltage Directive	2014/35/EU
EMC Directive	2014/30/EU
RoHS Directive	2011/65/EC

References to the relevant harmonised standards used or references to the other technical specifications in relation to which conformity is declared:

EN 61010-1:2010	Safety requirements for electrical equipment for measurement, control and laboratory use. Part 1: General requirements.
EN 61010-2-051:2015	Particular requirements for laboratory equipment for mixing and stirring.
EN 61326-1:2013	Electrical equipment for measurement, control and laboratory use. EMC requirements. Part 1: General requirements (Class A).
CFR Part 15: 2013	Subpart B - Unintentional radiators. (Class A)

Signed for and on behalf of the above manufacturer

Additional Information Year of CE Marking: 2009 (SHM1), 2018 (SHM3)

Place of Issue Stone, Staffordshire, UK

Date of Issue 11 July 2018

Authorised Representative Neil Pomeroy

Title Technical Director

Signature



Cole-Parmer Ltd - UK

Beacon Road,
Stone,

Staffordshire,
ST15 0SA,

United Kingdom

Tel: +44 (0)1785 812121

Email: cpinfo@coleparmer.com

Web: www.stuart-equipment.com