

---

INSTALLATION INSTRUCTIONS

# ESP M1/M1R mains protectors

ESP 120 M1, ESP 208 M1, ESP 240 M1,  
ESP 415 M1, ESP 277 M1, ESP 480 M1  
and M1R variants



# Contents

Key points of installation	<b>1</b>
Before installation	<b>2</b>
Installation	<b>3</b>
Installation check	<b>4</b>
Neutral-earth warning light	<b>5</b>
Status indication	<b>6</b>
Remote indication	<b>7</b>
Maintenance	<b>8</b>
Application Notes	<b>9</b>
Remote display drilling template	<b>10</b>

---

## INTRODUCTION

This document explains how to install Furse Electronic Systems Protectors for three phase mains power supplies:

**Single phase ESP 120 M1, Three phase ESP 208 M1 and ESP 208 M1R, Single phase ESP 240 M1, Three phase ESP 415 M1 and ESP 415 M1R, Single phase ESP 277 M1, Three phase ESP 480 M1 and ESP 480 M1R**

These instructions are prefaced by a summary of the **Key points of installation**. Each key point is explained in detail in the section entitled **Installation**.



### **Safety note:**

Warning! Installation by person with electrotechnical expertise only.

Warnung! Installation nur durch elektrotechnische Fachkraft.

Avvertenza! Fare installare solo da un elettricista qualificato.

Avertissement! Installation uniquement par des personnes qualifiées en électrotechnique.

Advertencia! La instalación deberá ser realizada únicamente por electricistas especializados.

ESP protector installation should be conducted by a qualified competent person and comply with all relevant Regulations and Legislation (including BS 7671 Wiring Regulations and Building Regulations). Incorrect installation will impair the effectiveness of ESP protectors.

Always handle cables by their insulation. Never work on ESP protectors, earthing or their cables during a storm.

**Installation instructions for mains wire-in protectors**

## **1. Key points of installation**

- 1.1** Install protectors very close to the power supply to be protected, either within the distribution panel or directly alongside it.
- 1.2** Mount units within a panel or WBX enclosure.
- 1.3** Units are installed in parallel.
- 1.4** Connect to phases, neutral and earth.

NOTE: Units must have a neutral connection (see 3.4).

- 1.5** Units installed at power distribution boards can be installed either:
  - on the load side of the incoming isolator, or
  - on the closest available outgoing way to the incoming supply
- 1.6** Provide a means of isolation for the ESP unit.
- 1.7** The connecting leads to phase/live terminals should be suitably fused (125 A maximum) ensuring full discrimination with the immediate upstream supply fuse.

- 1.8** Connecting leads should be 10 mm<sup>2</sup> multi stranded cable.
- 1.9** Keep the connecting leads as short as possible and ideally less than 25 cm (10 inches) in length. This may be better achieved with the equivalent M1R with remote display mounting flexibility.
- 1.10** Bind the connecting leads tightly over their entire length.
- 1.11** Maximum torque for power terminals is 2.65Nm, wire stripping length 17mm.
- 1.12** Maximum torque for remote contact is 0.25Nm, wire stripping length 7mm.

## 2. Before installation

- 2.1 Check that the voltage between neutral and earth does not exceed 10 volts.

If this voltage does exceed 10 volts, the installation is unsafe.

Find and rectify the cause of this fault before proceeding.

- 2.2 Make sure that the supply voltage is suitable for the unit.

	Supply Rated Voltage (VRMS)	Unit Voltage Range (VRMS)
ESP 120 M1 Phase to Neutral/Earth	110/120/127	90-150
ESP 208 M1 and ESP 208 M1R Phase to Phase	190/208/220	156-260
ESP 240 M1 Phase to Neutral/Earth	220/230/240	200-280
ESP 415 M1 and ESP 415 M1R Phase to Phase	380/400/415	346-484
ESP 277 M1 Phase to Neutral/Earth	240/254/277	232-350
ESP 480 M1 and ESP 480 M1R Phase to Phase	415/440/480	402-600



**Figure 1:**  
**ESP 415 M1**  
**installed**  
**inside a power**  
**distribution**  
**panel.**

### **3. Installation**

#### **3.1 Location**

Protectors need to be installed very close to the power supply to be protected. Usually the protector will be installed at a power distribution panel either inside it (Figure 1) or right next to it (Figure 2).

#### **3.2 Enclose the ESP unit**

The ESP unit has exposed terminals. For electrical safety, the unit must be installed within a panel or enclosure. For standard single and three phase units, where possible, install the unit within the power distribution panel behind a suitable viewing window.





**Figure 2:**  
**ESP 415 M1 installed next to a power distribution panel.**

Alternatively, for three phase units, a remote display M1R option is available. These units can be installed within the power distribution panel with the remote display mounted on the front of the panel.

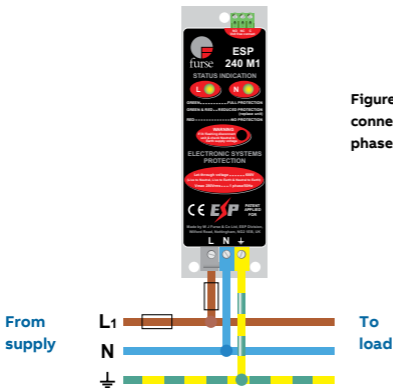

**Figure 3: Parallel connection for single phase supplies.**

When mounting the units in existing metal panels or enclosures, ensure that the enclosure is securely bonded to the earth bar to which the ESP unit will be connected.

If it is not possible to install the unit within the distribution panel it should be mounted in a separate enclosure, see Figure 2, as close as possible to the distribution panel (see 3.9 - Length of connecting leads). Gland the enclosure onto the power distribution panel. Suitable enclosures are available from Furse.

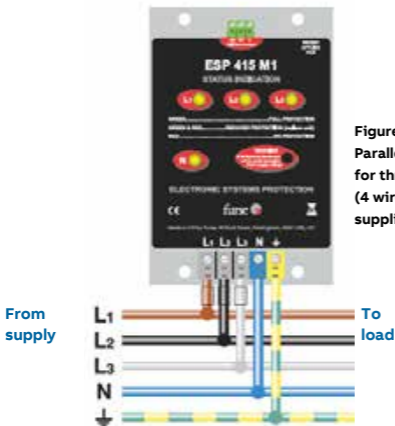
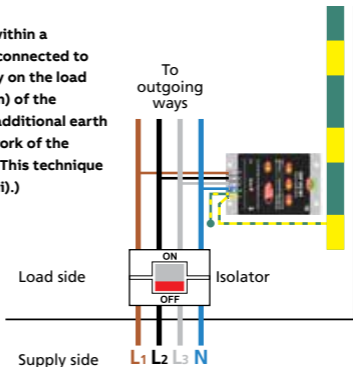

Figure 4:  
Parallel connection  
for three phase star  
(4 wire and earth)  
supplies.

### 3.3 Parallel connection

ESP mains wire-in protectors are connected in parallel with the supply to be protected. See Figure 3. The connecting leads do not carry the load current of the supply, only the current associated with suppressing the transient overvoltage.

**Figure 5:**  
**ESP unit mounted within a distribution board connected to the incoming supply on the load side (ie downstream) of the isolator. (Note the additional earth bond to the metalwork of the distribution board. This technique is explained in 3.9(iii).)**



Figures 3 & 4 show connection diagrams for single phase and three phase star power supplies.

Connecting leads to the unit need to be kept short in order to minimise additive inductive voltages.

### **3.4 Connection to phase, neutral and earth**

Connections are made to each supply conductor including earth. Terminals marked L, N,  $\perp$  (single phase units) or L1, L2, L3, N,  $\perp$  (three phase units) must be connected to phase/live, neutral and earth respectively.

**Under no circumstances must the ESP unit be installed without connection to its neutral.**

Where no neutral is present (eg delta supplies) the neutral (N) terminal on the ESP unit must be connected to earth in addition to the earth ( $\perp$ ) terminal. This will result in a greatly increased earth leakage current. On some delta supplies the voltage between phase and earth/ neutral may exceed the rating of the ESP unit. Consequently, the supply's phase to earth voltage must be checked before installing the ESP unit.

**We recommend that you consult ABB Furse ESP before installing ESP units on delta supplies.**

### **3.5 Connection point**

#### **(a) Protecting supplies feeding equipment in the building**

The ESP unit is typically connected to the power supply at a power distribution board/panel, either:

- (i) on the load side of the incoming isolator (Figure 5).
- (ii) on the closest available outgoing way to the incoming supply (ie the incoming isolator).

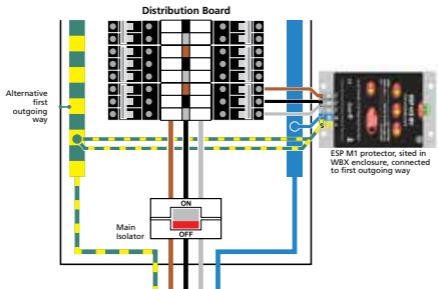
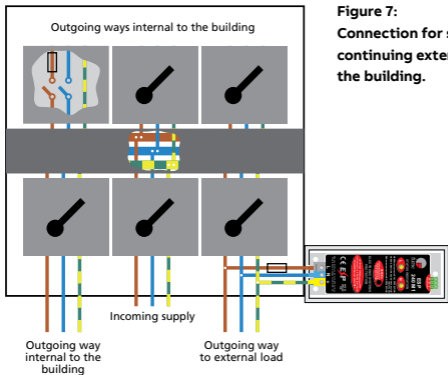

**Figure 6:**

**Three phase ESP protector connected to the nearest available outgoing (MCB) way to the incoming supply. The MCB also provides the means of isolation. Since there is insufficient space within the distribution board the ESP unit has been mounted within a separate enclosure, directly alongside the board. Note the double connection to earth, in order to compensate for the long connecting leads. (See 3.9 Length of connecting leads - this also gives an alternative technique in 3.9(iii).)**

The ESP unit can be connected via one of the distribution board's outgoing fuseways or circuit breakers.

Ideally, the ESP unit should be connected to the outgoing way which is nearest to the incoming supply (or isolator). See Figure 6.



**Figure 7:**  
**Connection for supplies**  
**continuing external to**  
**the building.**

On small, compact, metal cased distribution boards, (such as small MCB boards) the first way is preferable, although any outgoing way is suitable.

On a large board such as a cubicle switchboard, it is better to install the protector on the load side of the incoming isolator

(eg in the metering section) for optimal protection.

- (iii) directly to the busbars via suitable HRC fuses, switch fuses or MCCBs - see Section 3.7.

## (b) Protecting supplies going out of the building

The connection methods 3.5a (i to iii) are not suitable for protecting a power distribution board which provides a supply to outside the building - either to a separate building or some other external load (eg site lighting).

To protect the equipment inside the building, from transient overvoltages entering the board on the outgoing feed, protection should be installed close to the external load. See Figure 7.

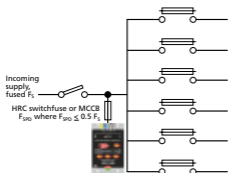

**Figure 8:**  
ESP unit installed on incoming side of distribution board.

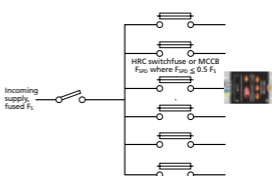

**Figure 9:**  
Installation of ESP unit on first outgoing way of distribution board.

## 3.6 Isolation

It is good practice to be able to isolate or disconnect the ESP unit from the supply. The supply to the entire distribution board should not be switched off on many computer power supplies and other critical loads.



**Figure 10:**  
**Busbar mounted HRC fuse at the end of the live connecting lead.**

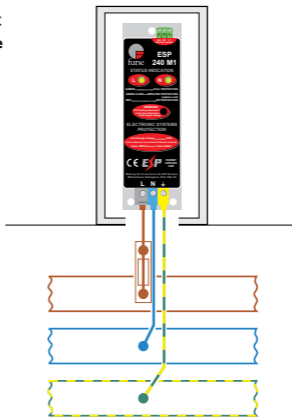

The means of isolation should therefore be installed in the connection to the ESP unit. Figures 8 & 9 show example connection schematics. Where it is also necessary to fuse the connection to the ESP unit (see 3.7 Fuse connecting leads) this can be achieved through use of a switchfuse, MCCB or type 'C' MCB.

### **3.7 Fuse connecting leads**

The connecting leads to the phase/live terminals of the ESP units should be fused. This is to protect the

connecting leads in the event of a short circuit. The fuse to the ESP unit ( $F_{SPD}$ ) should be lower than the upstream supply fuse  $F_S$  by a sufficient enough factor to ensure fuse discrimination. As a general guide a factor of at least 2 could be used ( $F_{SPD} \leq 0.5 F_S$ ), where the maximum fuse to the ESP unit required is 125 Amps (if the supply fuse is 250 Amps or greater).

Refer to the fuse manufacturer's operating characteristics to ensure discrimination, particularly where an installation includes a mixture of types of fuse, or of fuses and circuit breakers.

Live/phase connecting leads can be fused by either:

- (a) installing appropriate high rupture capacity (HRC) fuses or switchfuses in the connecting leads at the supply end of the lead (See Figure 10), or
- (b) installing up to a 125 Amp circuit breaker (MCCB or type 'C' MCB).

Where the ESP unit is installed via an outgoing way (3.5b earlier) this should incorporate up to a 125 Amp HRC fuse or circuit breaker.

### 3.8 Size of connecting leads

The connecting leads between the terminals of the ESP unit and the power supply, should be 10 mm<sup>2</sup> multi stranded conductor (copper). If required, the terminals on the ESP unit will accept connecting leads of up to 25 mm<sup>2</sup>.

### 3.9 Length of connecting leads

The connecting leads should be kept as short as possible and ideally should not exceed 25 cm (10 inches) from the busbars to the unit's terminals. **ESP units can be mounted upside down or on their side if this facilitates shorter connecting leads.**

**WARNING:** The longer the connecting leads (between the mains cable or busbars and the terminals of the ESP unit) the greater the additive voltage let-through by the installed protector.

If the resultant let-through voltage is higher than the susceptibility level of the equipment to be protected, damage will result.

ESP protectors with remote display units (M1R variants) allow the protector to be mounted with short connecting leads whilst allowing the display to be positioned independently (eg conveniently on the front of the panel).

The display is connected to the protector via the supplied 1 m cable (2 m or 4 m cable optional - contact ABB Furse).

The remote display drilling template can be found at the back of these instructions.

Connecting leads up to 50 cm (20 inches) can be used when:

- (i) two sets of 6 mm<sup>2</sup> cables are used (ie two sets of live, neutral and earth conductors). Each set of conductors is tightly bound together, using Ty-Raps<sup>®</sup>, tape or spiral wrap.

This should be done for the entire length of the cable or as far as is possible. The two sets of bound conductors should be separated in their routing. Ideally a distance of 10 cm (4 inches) should be maintained between the two sets of conductors as far as possible. See Figure 11.

**Figure 11:**

**For connecting leads of up to 50 cm use two sets of conductors (L1, L2, L3, N,  $\perp$  ). Each set of conductors has been tightly bound and separated in their routing.**



- (ii) alternatively, if only one conductor needs to be longer than 25 cm then use a pair of separated (as above) conductors to make that connection. See Figure 6.
- (iii) for metal distribution boards, if only the earth connection needs to be longer than 25 cm, the following procedure is suggested (See Figure 5):
  - (a) using 6 mm<sup>2</sup> cable make one connection from the ESP unit to the earth bar.
  - b) a second short and direct connection, again using 6 mm<sup>2</sup> cable, should be taken from the ESP unit to the metalwork of the distribution board.
  - (c) bond the earth bar to the metalwork of the distribution board.

The techniques outlined above (i-iii) are designed to minimise the inductance associated with the connecting leads.

### **3.10 Bind connecting leads**

Connecting leads should be tightly bound together using Ty-Raps®, tape or spiral wrap. This should be done for the entire length of the cable or as far as is possible. See Figure 11.

#### 4. Installation check

The ESP unit should now be correctly installed. Switch the power supply on. Check that a green LED per phase and neutral is lit. See Figure 12. The unit is now fully operational.

Watch the WARNING light for 30 seconds. If it is flashing or lit there is a problem with your installation (see opposite).



**Figure 12:**  
Status indication lights showing full protection on all phases. On M1R units, status indication is shown on the remote display unit.

## 5. **Neutral-earth warning light**

If the WARNING light is illuminated there is an excessive voltage present between neutral and earth.

**The WARNING light should never be illuminated.**

### (a) **Illumination at time of installation**

If the WARNING light flashes as soon as the mains supply to the ESP unit is turned on, one of the phase/live cables may have been connected to neutral and the neutral to phase/live. Isolate or disconnect the ESP unit immediately. Check the phase/live and neutral connections and if a mistake has been made, correct it. If all the phase/live and neutral connections are correct, there is a fault with the mains supply (see (b) - below).  
Note: The ESP unit may have suffered damage - check the status indication (see section 6).

### (b) **Illumination at any time**

The WARNING light will flash when the neutral to earth voltage exceeds 30 Volts. The faster the flashing, the higher the voltage between neutral and earth (at very high voltages the WARNING light may appear to be permanently illuminated). **Disconnect the ESP protector immediately and check the mains supply.**

The ESP protector should not be reconnected until the cause of the fault has been identified and rectified.

Note: The ESP unit may have suffered damage - check the status indication (see section 6).

## 6. Status indication

ESP units give a continuous visual display of their status. They have a two colour indicator light, for each phase and neutral:

**Green only** = Full protection, power on.

**Green + Red** = WARNING. Reduced protection, replace unit as soon as possible.

**Red only** = NO PROTECTION. Replace ESP unit immediately.

**No lights** = No power connection or system fault. Check external fuses and connections.



## 7. Remote indication

A remote indication of the reduced protection state is provided for linking the protector to a building management system, remote telemetry, PLC or directly to an indication light or buzzer.

The unit has both a normally open and a normally closed volt free contact. The terminal for the volt free contact accepts 1.5 mm<sup>2</sup> cable (solid or stranded conductor) and is located on the top of the ESP unit. It has three terminals, marked:

**NO** = Normally Open **NC** = Normally Closed **C** = Common

The normally open (NO) contact is open when the ESP unit is healthy and power is present.

The normally closed (NC) contact is closed when the unit is healthy and power is present.

As well as providing warning of the reduced protection state, the normally closed volt free contact can also be used to signal power loss on one or more phases, eliminating the need for special relays. See Figure 13.

The ESP units remote indication is rated at 1 Amp, 250 V AC.

Note: For reliable contact operation, the minimum permissible load is 10 mA, 5 V DC.

	Unit Healthy		Reduced or No protection	
	NO	NC	NO	NC
Power Present	<b>OPEN</b>	CLOSED	<b>CLOSED</b>	OPEN
Power Absent	<b>CLOSED</b>	OPEN	<b>CLOSED</b>	OPEN

**Figure 13:**  
Operation of normally closed (NC) and normally open (NO) volt free contact.

## 8. Maintenance

Maintenance should be conducted at least once a year and also following lightning activity. Visually check:

- Visual status indication lights (see Status indication for interpretation)
- Condition of connecting leads and terminations

### Environment

Consider the protection of the environment!

Used electrical and electronic equipment must NOT be disposed of with domestic waste. The device contains valuable raw materials which can be recycled. Therefore, contact ABB for disposal of this equipment.



## **9. Application notes**

### **9.1 ESP coordination**

ESP M1/M1R units are designed to fully coordinate with ESP units of equivalent system voltage on the same installation. For example the ESP 415 M2 located at the main distribution panel would coordinate effectively with the ESP 415 M1 unit typically located at sub-distribution panels. No additional de-coupling elements such as inductors are needed to ensure ESP units achieve coordination.

Always ensure ESP units are used on the same installation to ensure coordination. Mixing ESP units with alternative manufacturers' units could result in damage to both protection units and connected equipment through poor coordination.

### **9.2 RCD units**

ESP units should ideally be installed before (or upstream of) residual current devices (RCDs) and not on the load side. ESP units should only be installed on the load side of the RCDs if the load in question is external to the building.

This should help to reduce any spurious tripping of such devices due to transient overvoltages. Where ESP units are installed after (or downstream) of RCDs, special transient hardened RCDs (type 'S') should be used (e.g. ABB F 200 A selective type series).

### **9.3 Insulation tests (flash testing)**

The ESP unit should be fully disconnected from the circuit before testing. Otherwise the ESP unit will treat the insulation test as a transient overvoltage and control the voltage to a low level - thereby defeating the object of the test.

### **9.4 Duplex configuration**

For systems demanding extremely high reliability, ESP units can be connected in duplex format. The use of two units will achieve an improvement in performance and increased lifetime over a single ESP unit at high discharge current levels. Each unit should have its own (separate) wiring and its own isolation.

If possible the two units should be connected to the power supply a short distance apart either:

(a) onto the first two outgoing ways

(b) up to a metre apart on the incoming power supply

## **9.5 Installing three phase units on single phase supplies**

If a three phase unit is installed on a single phase mains supply (or a supply in which one or two phases are not in use), the ESP units spare (or unused) live terminal(s) should be connected to live, otherwise its indication lights and volt free contact will not work correctly. The preferred approach is to take a connecting lead from each spare terminal to the supply live. However, it is also possible to connect the ESP units spare terminal(s) to whichever live terminal is in use at the unit.

## **9.6 Use of powered screwdrivers**

The use of powered screwdrivers is not recommended unless measures are taken to ensure screws are tightened correctly and not damaged

